



**Invitation for Bids**

**Bid No. IFB-038-23-JJ**

**CLARIFIER NO. 3 REPAIR  
ECSD Project Number: 22-9525**

**FOR THE  
CITY OF HOLLYWOOD, FLORIDA (CITY)**

**IFB Issue Date:** January 10, 2023

**Questions Due Date:** January 30, 2023

**Submittal Due Date:** February 9, 2023, at 3 p.m. ET

**CITY OF HOLLYWOOD**  
**Bid No. IFB-038-23-JJ**  
**CLARIFIER NO. 3 REPAIR**  
**22-9525**  
**TABLE OF CONTENTS**

**SECTION I – INTRODUCTION**

- 1.1 Purpose
- 1.2 Pre-bid Conference
- 1.3 BidSync
- 1.4 Point of Contact
- 1.5 Cone of Silence

**SECTION II – SPECIAL TERMS AND CONDITIONS**

- 2.1 Addenda, Changes, and Interpretations
- 2.2 Dimensions, Quantities and Subsurface Information
- 2.3 Trench Safety Form
- 2.4 Changes and Alterations
- 2.5 Bidder's Costs
- 2.6 Pricing/Delivery
- 2.7 Price Validity
- 2.8 No Exclusive Contract
- 2.9 Responsive
- 2.10 Responsible
- 2.11 Minimum Qualifications
- 2.12 Award of Contract
- 2.13 Execution Of Contract:
- 2.14 Failure To Execute Contract, Bid Guaranty Forfeited
- 2.15 Manufacturer/Brand/Model Request
- 2.16 Permits and Fees
- 2.17 Contract Security
- 2.18 Contract Period
- 2.19 Bid Guaranty
- 2.20 Warranties of Usage
- 2.21 Rules and Submittals of Bids
- 2.22 Tie Breaker
- 2.23 Conflict of Interests Prohibited
- 2.24 Protest Procedure
- 2.25 Insurance Requirements
- 2.26 Uncontrollable Circumstances (Force Majeure)
- 2.27 Supplier Portal (Oracle) Payment Method
- 2.28 Debarred or Suspended Bidders or Proposers
- 2.29 Payment and Performance Bond
- 2.30 Public Records

**SECTION III – SCOPE OF SERVICES**

- 3.1 Project Description
- 3.2 Technical Specifications
- 3.3 Contractor Qualifications
- 3.4 Subcontractors
- 3.5 Deliverables and Objectives
- 3.6 Project Schedule / Timeline
- 3.7 Questions
- 3.8 Substantial Completion

**SECTION IV – GENERAL TERMS & CONDITIONS**

**SECTION V – FORM(S)**

- Form 1 Submittal Checklist Form\*
- Form 2 Acknowledgement and Signature Page
- Form 3 Bid Form\*
- Form 4 Vendor Reference Form
- Form 5 Hold Harmless and Indemnity Clause
- Form 6 Non-Collusion Affidavit
- Form 7 Sworn Statement...Public Entity Crimes
- Form 8 Certifications Regarding Debarment...
- Form 9 Drug-Free Workplace Program
- Form 10 Solicitation, Giving, and Acceptance...
- Form 11 W-9 (Request for Taxpayer Identification)
- Form 12 Trench Safety Form\*
- Form 13 Bid Guaranty Form
- Form 14 List of Subcontractors
- Form 15 Information Required from Bidders
- Form 16 Proposal

**SECTION VI – ATTACHMENTS/EXHIBITS**

- Attachment A – Contract Documents, Payment, and Performance Bond
- Attachment B – General Conditions, Public Utilities
- Attachment C - Supplementary General Conditions
- Attachment D – Technical Specifications
- Attachment E – Drawings

## SECTION I – INTRODUCTION

### 1.1 **Purpose**

The City of Hollywood, Florida (City) is seeking bids from qualified and experienced firms, hereinafter referred to as the Contractor or Bidder, to provide construction services for the Oxygenation Flow Distribution Box Odor Control System Replacement for the City, in accordance with the terms, conditions, and specifications contained in this solicitation. Responses to this solicitation are due by **February 9, 2023, by 3:00 PM EST**, and will be opened in a virtual public setting on **February 9, 2023, at 3:00 PM EST** on at <https://Opengov.com/>.

Submittals shall be received electronically through OpenGov.

Submittals shall be considered an offer on the part of the bidder/proposer, which offer shall be deemed accepted upon approval of the City, and in case of default, the City reserves the right to accept or reject any or all bids/proposals, to waive irregularities and technicalities, and request new bids/proposals. The City also reserves the right to award any resulting agreement as it deems will best serve the interests of the city.

### 1.2 **Pre-bid Conference and/or Site Visit (Non-Mandatory)**

There will be a non-mandatory pre-bid conference and/or site visit scheduled for this solicitation. Attendance is required if the event is mandatory, and in the event that it is non-mandatory, it is strongly suggested that all Contractors attend the pre-bid conference and/or site visit to receive information that may be critical to their understanding of this solicitation.

Please keep in mind that site visits at other times might not be available. It is the sole responsibility of the Contractor to become familiar with the scope of the City's requirements prior to submitting a bid. No variation in price or conditions shall be permitted based upon a claim of ignorance. Submission of a bid will be considered evidence that the Bidder has familiarized themselves with the nature and extent of the work, equipment, materials, and labor required.

### 1.3 **OpenGov**

The City of Hollywood uses OpenGov (<https://procurement.opengov.com/portal/hollywoodfl>) to administer the competitive solicitation process, including but not limited to soliciting bids, issuing addenda, posting results and issuing notification of an intended decision.

The City shall not be responsible for a Bidders inability to submit a bid by the bid end date and time for any reason, including issues arising from the use of OpenGov.

### **Point of Contact**

For information concerning procedures for responding to this solicitation, contact the Point of Contact within the Office of Procurement Services, Jean Joinville, Senior Purchasing Agent at [jjoinville@hollywoodfl.org](mailto:jjoinville@hollywoodfl.org) or by phone at (954) 921-3290, or Staci Alli, Office Assistant I at [salli@hollywoodfl.org](mailto:salli@hollywoodfl.org) or by phone at 954-921-3222. Such contact is to be for clarification purposes only. All questions must be submitted in writing via OpenGov by **January 30, 2023, by 5:00 PM EST** in order to receive a response.

Project Manager: Juan Jose Figueroa, Department of Public Utilities, email: [jfigueroa@hollywoodfl.org](mailto:jfigueroa@hollywoodfl.org) or by phone: (954) 921-3930.

For information concerning technical specifications, please utilize the question / answer feature provided by OpenGov at <https://procurement.opengov.com/portal/hollywoodfl>. Questions of a material nature must be received prior to the cut-off date specified in the solicitation schedule. Material changes, if any, to the scope of services or bidding procedures will only be transmitted by written addendum. (See addendum section of OpenGov Site). Bidders please note: No part of your bid can be submitted via FAX. No variation in price or conditions shall be permitted based upon a claim of ignorance. Submission of a bid will be considered evidence that the Bidder has familiarized themselves with the nature and extent of the work, and the equipment, materials, and labor required. The entire bid response must be submitted in accordance with all specifications contained in this solicitation. The questions and answers submitted in OpenGov shall become part of any contract that is created from this solicitation.

It is the sole responsibility of the Bidder to ensure that their bid is submitted electronically through OpenGov at <https://procurement.opengov.com/portal/hollywoodfl>.

## **1.5 Cone of Silence**

The City of Hollywood City Commission adopted Ordinance No. O-2007-05, which created Section 30.15(F) imposing a Cone of Silence for certain City purchases of goods and Services.

The Cone of Silence refers to limits on communications held between vendors and vendor's representatives and City elected officials, management and staff during the period in which a Formal Solicitation is open.

The Ordinance does allow potential vendors or vendor's representatives to communicate with designated employees for the limited purpose of seeking clarification or additional information. The names and contact information of those employees that may be contacted for clarification or additional information are included in the solicitation.

The Cone of Silence does not prohibit a vendor or vendor's representative from communicating verbally, or in writing with the City Manager, the City Manager's designee, the City Attorney or the City Attorney's designee on those procurement items to be considered by the City Commission.

The Cone of Silence does not prohibit a vendor or vendor's representative from making public presentations at a duly noticed pre-bid conference or duly noticed evaluation committee meeting or from communicating with the City Commission during a duly noticed public meeting.

The Cone of Silence shall be imposed when a formal competitive solicitation has been issued and shall remain in effect until an award is made, a contract is approved, or the City Commission takes any other action which ends the solicitation.

To view the Cone of Silence, go to the City of Hollywood Code of Ordinance online, and view [Section 30.15F](#).

All communications regarding this bid should be sent in writing to the Procurement Services Division as identified in this bid.

*END OF SECTION*

## **SECTION II - SPECIAL TERMS AND CONDITIONS**

### **2.1 Addenda, Changes, and Interpretations**

It is the sole responsibility of each firm to notify the Point of Contact utilizing the question / answer feature provided by OpenGov and request modification or clarification of any ambiguity, conflict, discrepancy, omission or other error discovered in this competitive solicitation. Requests for clarification, modification, interpretation, or changes must be received prior to the Question and Answer (Q & A) Deadline. Requests received after this date may not be addressed. Questions and requests for information that would not materially affect the scope of services to be performed or the solicitation process will be answered within the question / answer feature provided by OpenGov and shall be for clarification purposes only. Material changes, if any, to the scope of services or the solicitation process will only be transmitted by official written addendum issued by the City and uploaded to OpenGov as a separate addendum to the solicitation. Under no circumstances shall an oral explanation given by any City official, officer, staff, or agent be binding upon the City and should be disregarded. All addenda are a part of the competitive solicitation documents and each firm will be bound by such addenda. It is the responsibility of each to read and comprehend all addenda issued.

### **2.2 Dimensions, Quantities and Subsurface Information**

Dimensions, quantities, and subsurface information supplied by the City are in no way warranted to indicate true amounts or conditions. Bidders/Contractors shall neither plead misunderstanding or deception nor make claims against the City if the actual amounts, conditions, or dimensions do not conform to those stated. Any "Outside" reports made available by the Engineer are neither guaranteed as to accuracy or completeness, nor a part of the Contract Documents.

### **2.3 Trench Safety Form**

The Trench Safety Form included in the Bid Documents must be completed and signed. Noncompliance with this requirement may invalidate the bid.

### **2.4 Changes and Alterations**

Bidder may change or withdraw a Bid at any time prior to Bid submission deadline; however, no oral modifications will be allowed. Modifications shall not be allowed following the Bid deadline.

### **2.5 Bidder's Costs**

The City shall not be liable for any costs incurred by Bidders in responding to this solicitation.

### **2.6 Pricing/Delivery**

All pricing must include delivery and installation and be quoted FOB: Destination, unless specified otherwise in Section III.

### **2.7 Price Validity**

Prices provided in this solicitation shall be valid for at least One-Hundred and Twenty (120) days from time of solicitation opening unless otherwise extended and agreed upon by the City and Bidder.

### **2.8 No Exclusive Contract**

Bidder agrees and understands that the contract shall not be construed as an exclusive arrangement and further agrees that the City may, at any time, secure similar or identical services from another vendor at the City's sole option.

### **2.9 Responsive**

In order to be considered responsive to the solicitation, the firm's bid shall fully conform in all material respects to the solicitation and all of its requirements, including all form and substance.

**2.10 Responsible**

In order to be considered as a responsible firm, firm shall be fully capable to meet all of the requirements of the solicitation and subsequent contract, must possess the full capability, including financial and technical, to perform as contractually required, and must be able to fully document the ability to provide good faith performance.

**2.11 Minimum Qualifications**

To be eligible for award of a contract in response to this solicitation, the Bidder must demonstrate that they have successfully completed services, as specified in Section III of this solicitation, are normally and routinely engaged in performing such services, and are properly and legally licensed (if required) to perform such work. Bidder must possess, and be able to provide the City with any and all required Federal, State, County and/or municipal licenses, and occupational licenses. Bidder must be able to provide proof of valid licensing for all subcontractors and/or material suppliers hired by the contractor, if requested. In addition, the Bidder must have no conflict of interest with regard to any other work performed by the Bidder for the City.

**2.12 Award of Contract**

Award may be in the aggregate, or by line Item, or by group, whichever is determined to be in the best interest of the City.

The Contract will be awarded only to a Bidder, who in the opinion of the Engineer, is fully qualified to undertake the work, quoting the lowest price, for that product/service that will best serve the needs of the City. The City reserves the right before awarding the Contract to require a Bidder to submit such evidence of his qualifications as it may deem necessary and may consider any available evidence of his financial status, technical qualifications, and other qualifications and abilities.

The City also reserves the right to accept or reject any or all bids, part of bids, and to waive minor irregularities or variations to specifications contained in bids, and minor irregularities in the bidding process. The City also reserves the right to award the contract on a split order basis, lump sum basis, individual item basis, or such combination as shall best serve the interest of the City.

**2.13 Execution Of Contract**

The Bidder to whom the Contract is awarded shall, within ten days of the date of award, execute and deliver three (3) copies of the following to the Engineer.

- A. The Contract
- B. Performance and Payment Bond
- C. Evidence of required Insurance
- D. Proof of authority to execute the Contract
- E. Proof of authority to execute the Bond on behalf of the Awardee
- F. List of Subcontractors, estimated Contract Value for each and proof that such subcontractors possess all required Federal, State, County and/or municipality licenses, including but not limited to certified of competency and occupational license

The above documents must be furnished, executed and delivered before the Contract will be executed by the City. The Contract shall not be binding upon the City until it has been executed by the City and a copy of such fully executed Contract is delivered to the Contractor.

**2.14 Failure To Execute Contract, Bid Guaranty Forfeited**

Should the Bidder to whom the Contract has been awarded refuse or fail to complete the requirements of Section 2.13 above within ten (10) days after Notice of Award, the additional time in days (including weekends) required to CORRECTLY complete the documents will be deducted, in equal amount, from the Contract Time, or the City may elect to revoke the Award. The Bid Guaranty of any Bidder failing to execute the awarded Contract shall be retained by the City and the Contract awarded as the Commission desires.

**2.15 Manufacturer/Brand/Model Specific Request**

This is a manufacturer/brand/model specification. No substitutions will be allowed unless specified in Form 3 or Attachment D – Technical Specifications.

**2.16 Permits and Fees** Refer to Attachment D – Technical Specifications (Section 01025 Basis of Payment)

**2.17 Contract Security**

When the awarded bidder delivers the executed contract to the City, it must be accompanied by the required bonds.

**2.18 Contract Period**

The initial contract term shall commence upon date of award by the City for a twelve-month term. In the event services are scheduled to end because of the expiration of this contract, the Contractor shall continue the service upon the request of the City as authorized by the awarding authority. The extension period shall not extend for more than 120 days beyond the expiration date of the existing contract. The Contractor shall be compensated for the service at the rate in effect when this extension clause is invoked by the City.

**2.19 Bid Guaranty**

A Bid Guaranty in the form of a Cashier's Check, Certified Check or Bid Bond executed by the Bidder and a qualified Surety in the amount of 5% of the Bid is required for this project.

**2.20 Warranties of Usage**

Any estimated quantities listed are for information and tabulation purposes only. No warranty or guarantee of quantities needed is given or implied. It is understood that the Contractor will furnish the City's needs as they arise.

**2.21 Rules and Submittals of Bids**

The signer of the bid must declare that the only person(s), company or parties interested in the proposal as principals are named therein; that the bid is made without collusion with any other person(s), company or parties submitting a bid; that it is in all respects fair and in good faith, without collusion or fraud; and that the signer of the bid has full authority to bind the principal bidder.

**2.22 Tie Breaker**

In cases where there is a tie for the bid award, the award shall be made by giving preference to the low bidder(s) with the following items (in this order): (1) maintenance of a drug-free workplace in accordance with the requirements of Florida Statutes Section 287.087, (2) local Hollywood vendor preference, (3) closest proximity/location to project site or City Hall, and/or (4) minority-owned or disadvantaged business status. If a tie still exists after the aforementioned tiebreakers are utilized, the Chief Procurement Officer will make a recommendation for award among the tied bidders.

## **2.23 Conflict of Interests Prohibited**

Any respondent submitting a response to this solicitation is responsible for being aware of, and complying with [Section 34.02](#) of the City Code of Ordinances. If you have questions concerning whether you may or may not need to comply with the ordinance, please contact the City of Hollywood, City Clerk's Office at 954-921-3211.

## **2.24 Protest Procedure**

Any respondent who is not recommended for award of a contract and who alleges a failure by the City to follow the City's [Procurement Code](#) or any applicable law may protest to the CPO, by delivering a letter of protest to the CPO in accordance with [Section 38.52](#) of the City's [Procurement Code](#) within five days after a notice of intent to award is posted on the City's web site, OPENGOV, City Clerk's Office, Open Government, and/or City's Sunshine Board (<https://www.hollywoodfl.org/Archive.aspx?AMID=140>).

## **2.25 Insurance Requirements**

Contractor shall maintain, at its sole expense, during the term of this agreement the following insurances:

The insurance required by Article 5.6 of the General Conditions, Public Utilities shall be as follows:

Any Sub-Contractor used by the contractor shall supply such similar insurance required of the contractor. Such certificates shall name the City of Hollywood as an Additional Insured.

### **A. Builders Risk (BR 1) - Installation Floater: (Not Applicable)**

### **B. General Liability (GL3):**

Prior to the commencement of work governed by this contract, the Contractor shall obtain General Liability Insurance. Coverage shall be maintained throughout the life of the contract and include, as a minimum:

1. Premises Operations
2. Products and Completed Operations
3. Blanket Contractual Liability
4. Personal Injury Liability
5. Expanded Definition of Property Damage

The minimum limits acceptable shall be:

- \$2,000,000 Combined Single Limit (CSL)

If split limits are provided, the minimum limits acceptable shall be:

- \$1,000,000 per Person
- \$2,000,000 per Occurrence
- \$100,000 Property Damage

An Occurrence Form policy is preferred. If coverage is provided on a Claims Made policy, its provisions should include coverage for claims filed on or after the effective date of this contract. In addition, the period for which claims may be reported should extend for a minimum of twelve (12) months following the acceptance of work by the City.

The City of Hollywood shall be named as Additional Insured on all policies issued to satisfy the above requirements.

### **C. General Liability (GLXCU):**

Recognizing that the work governed by this contract involves either underground exposures, explosive activities, or the possibility of collapse of a structure, the Contractor's General Liability Policy shall



include coverage for the XCU (explosion, collapse, and underground) exposures with limits of liability equal to those of the General Liability Insurance policy.

**D. Vehicle Liability (VL3):**

Recognizing that the work governed by this contract requires the use of vehicles, the Contractor, prior to the commencement of work, shall obtain Vehicle Liability Insurance. Coverage shall be maintained throughout the life of the contract and include, as a minimum, liability coverage for:

- Owned, Non-Owned, and Hired Vehicles

The minimum limits acceptable shall be:

- \$1,000,000 Combined Single Limit (CSL)

If split limits are provided, the minimum limits acceptable shall be:

- \$500,000 per Person
- \$1,000,000 per Occurrence
- \$100,000 Property Damage

The City of Hollywood shall be named as Additional Insured on all policies issued to satisfy the above requirements.

**E. Workers' Compensation (WC2):**

Prior to the commencement of work governed by this contract, the Contractor shall obtain Workers' Compensation Insurance with limits sufficient to respond to the applicable state statutes.

In addition, the Contractor shall obtain Employers' Liability Insurance with limits of not less than:

- \$500,000 Bodily Injury by Accident
- \$500,000 Bodily Injury by Disease, policy limits
- \$500,000 Bodily Injury by Disease, each employee

Coverage shall be maintained throughout the entire term of the contract.

**F. Pollution Liability Insurance**

The minimum limits of liability shall be:

- \$1,000,000 per each claim / \$2,000,000 aggregate

Coverage shall be provided by a company or companies authorized to transact business in the state of Florida and the company or companies must maintain a minimum rating of "A" and Class X, as assigned by the A.M. Best Company.

The policy must be endorsed to provide the City with (30) days' notice of cancellation.

If the Contractor has been approved by the Florida's Department of Labor, as an authorized self-insurer, the City shall recognize and honor the Contractor's status. The Contractor may be required to submit a Letter of Authorization issued by the Department of Labor and a Certificate of Insurance, providing details on the Contractor's Excess Insurance Program.

If the Contractor participates in a self-insurance fund, a Certificate of Insurance will be required. In addition, the Contractor may be required to submit updated financial statements from the fund upon request from the City.

Any sub-consultant shall supply such similar insurance required of the Consultant. Such certificates shall name the City as additional insured in the general liability and auto liability policies.

**2.26 Uncontrollable Circumstances (Force Majeure)**

The City and Contractor will be excused from the performance of their respective obligations under this agreement when and to the extent that their performance is delayed or prevented by any circumstances beyond their control including, fire, flood, explosion, strikes or other labor disputes, acts of God or public emergency, war, riot, civil commotion, malicious damage, act or omission of any governmental authority, delay or failure or shortage of any type of transportation, equipment, or service from a public utility needed for their performance, provided that:

**2.26.1** The non performing party gives the other party prompt written notice describing the particulars of the Force Majeure including, but not limited to, the nature of the occurrence and its expected duration, and continues to furnish timely reports with respect thereto during the period of the Force Majeure;

**2.26.2** The excuse of performance is of no greater scope and of no longer duration than is required by the Force Majeure; and

**2.26.3** No obligations of either party that arose before the Force Majeure causing the excuse of performance are excused as a result of the Force Majeure; and

**2.26.4** The non-performing party uses its best efforts to remedy its inability to perform. Notwithstanding the above, performance shall not be excused under this Section for a period in excess of two (2) months, provided that in extenuating circumstances, the City may excuse performance for a longer term. Economic hardship of the Contractor will not constitute Force Majeure. The term of the agreement shall be extended by a period equal to that during which either party's performance is suspended under this Section.

**2.27 Supplier Portal (Oracle) Payment Method**

The City has implemented software that contains a supplier portal allowing suppliers to submit and update their information via the supplier portal. New suppliers will be required to register; and current suppliers will need to confirm and update their information.

Firms are responsible for ensuring that all contact, payment, and general information is updated at all times, and will not hold the City liable for any inaccurate information.

**2.28 Debarred or Suspended Bidders or Proposers**

Firm(s) certifies, by submission of a response to this solicitation, that neither it nor its principals and subcontractors are presently debarred or suspended by any federal, state, county or municipal department or agency.

**2.29 Payment and Performance Bond**

A Performance Bond and a Payment Bond each equal to 100 percent of the total Bid will be required of the Awardee. The Bond must be written through a company licensed to do business in the State of Florida and be rated at least "A", Class X, in the latest edition of "Best's Key Rating Guide", published by A.M. Best Company. As per Florida Statute Section 255.05, the Contractor shall be required to record the payment and performance bonds in the public records of Broward County

**2.30 Public Records**

**A. Public Records/Trade Secrets/Copyright:**

**All responses will become the property of the City. The Consultant's response to the solicitation is a public record pursuant to Florida law and is subject to disclosure by the City pursuant to**

**Chapter 119.07, Florida Statutes (“Public Records law”). The City shall permit public access to all documents, papers, letters or other material submitted in connection with this solicitation and the Contract to be executed for this solicitation, subject to the provisions of Chapter 119, Florida Statutes.**

Any language contained in the Consultant’s response to the solicitation purporting to require confidentiality of any portion of the Consultant’s response to the solicitation, except to the extent that certain information is in the City’s opinion a Trade Secret pursuant to Florida law, shall be void. If a Consultant submits any documents or other information to the City that the Consultant claims is Trade Secret information and exempt from Florida Statutes Chapter 119.07 (“Public Records Laws”), the Consultant shall clearly designate that it is a Trade Secret and that it is asserting that the document or information is exempt. The Consultant must specifically identify the exemption being claimed under Florida Statutes 119.07. The City shall be the final arbiter of whether any information contained in the Consultant’s response to the solicitation constitutes a Trade Secret. The City’s determination of whether an exemption applies shall be final, and the Consultant agrees to defend, indemnify, and hold harmless the City and the City’s officers, employees, and agent, against any loss or damages incurred by any person or entity as a result of the City’s treatment of records as public records. In the event of Contract award, all documentation produced as part of the Contract shall become the exclusive property of the City. Proposals purporting to be subject to copyright protection in full or in part will be rejected.

EXCEPT FOR CLEARLY MARKED PORTIONS THAT ARE BONA FIDE TRADE SECRETS PURSUANT TO FLORIDA LAW, DO NOT MARK YOUR RESPONSE TO THE SOLICITATION AS PROPRIETARY OR CONFIDENTIAL. DO NOT MARK YOUR RESPONSE TO THE SOLICITATION OR ANY PART THEREOF AS COPYRIGHTED.

## **B. PUBLIC RECORDS GENERAL**

**IF THE CONSULTANT HAS QUESTIONS REGARDING THE APPLICATION OF CHAPTER 119, FLORIDA STATUTES, TO THE CONSULTANT’S DUTY TO PROVIDE PUBLIC RECORDS RELATING TO THIS CONTRACT, CONTACT THE CUSTODIAN OF PUBLIC RECORDS AT: (954-921-3211), pcerny@hollywoodfl.org, CITY CLERK’S OFFICE, 2600 HOLLYWOOD BLVD, HOLLYWOOD, FLORIDA 33020)**

Consultant shall:

1. Keep and maintain public records that ordinarily and necessarily would be required by the City in order to perform the service.
2. Upon request from the City’s custodian of public records, provide the City with a copy of the requested records or allow the records to be inspected or copied within a reasonable time at a cost that does not exceed the cost provided in Chapter 119, Florida Statutes.
3. Ensure that public records that are exempt or confidential and exempt from public records disclosure requirements are not disclosed except as authorized by law for the duration of the contract term and following completion of this contract if the Consultant does not transfer the records to the City.
4. Upon completion of the Contract, transfer, at no cost, to the City all public records in possession of the Consultant or keep and maintain public records required by the City to perform the service. If the Consultant transfers all public records to the City upon completion of this Contract, the Consultant shall destroy any duplicate public records that are exempt or confidential and exempt from public records

disclosure requirements. If the Consultant keeps and maintains public records upon completion of this Contract, the Consultant shall meet all applicable requirements for retaining public records. All records stored electronically must be provided to the City, upon request from the City's custodian of public records, in a format that is compatible with the information technology systems of the City. It is solely and exclusively the Contractor's responsibility to familiarize itself with Chapter 119, Florida Statutes, and to ensure compliance with its requirements.

*END OF SECTION*

## **SECTION III - SCOPE OF SERVICES**

### **3.1 Project Description**

Work under this Contract consists of civil, sitework, mechanical, structural, electrical, instrumentation and all related work necessary to repair the failed 16-inch diameter 90-degree elbow joint and pipe segment on the return sludge line (ductile iron pipe) located below grade within the 48-inch diameter influent line at Clarifier No. 3. Due to the location of the repair, this work includes dismantling, relocating/protecting and re-installing existing clarifier mechanism equipment (as necessary) once repair work is completed and deemed acceptable by the City. In addition, this work includes all construction sequencing requirements, all startup and training activities, and all other work required for a complete and operating facility. At the City's option, if deemed necessary, the work may also include complete replacement of the mechanism, fiberglass v-notched weirs, scum baffles, and/or density current baffles at Clarifier No. 3.

### **3.2 Technical Specifications**

Refer to Attachment D.

### **3.3 Contractor Qualifications**

The contract will be awarded only to a responsive contractor qualified by experience to do the Work specified. The bidder shall submit, prior to award of contract, satisfactory evidence of his experience in like Work and that he is fully prepared with the necessary organization, capital, equipment and machinery to complete the Work to the satisfaction of the City within the time limit stated. In addition to the above, the Contractor shall satisfy the following criteria:

1. The Bidder shall have successfully completed a minimum of three (3) relevant projects demonstrating experience with wastewater treatment facilities. These projects shall have been performed within the past five (5) years from the date of the Invitation to Bid.
2. Provide at least four (4) verifiable references for projects similar in size and scope or types of work as listed in this solicitation using the attached Form 4 - Vendor Reference Form.

Form 15 – Information Required from Bidders, shall be completed fully and accurately by the Contractor and submitted with the bid. Information included on the questionnaire will be used in evaluating the qualifications of the Contractor. The City reserves the right to request additional information not identified on the questionnaire.

### **3.4 Subcontractors**

For the City to be assured that only competent and qualified subcontractors will be employed on this project, each Bidder shall submit in the bid a list of the subcontractors performing work on this project. This subcontractors list shall include each firm's name, address, telephone number, contact person and work to be performed. Subcontractors shall be properly registered or licensed with the State of Florida, Broward County and the City of Hollywood. Subcontractors shall, in the City's opinion, be qualified both technically and financially to perform the work.

The City reserves the right to reject any subcontractor who is deemed by the City to be unacceptable technically or financially, or has previously performed work which the City believes to be unsatisfactory. No change may be made to this list of subcontractors by the Contractor, before or after contract award, without the express written consent of the City.

If, prior to award, the City rejects any subcontractor, the Contractor shall be afforded the opportunity to submit qualifications for an alternate subcontractor with no attendant increase in the base lump sum bid amount, adjustment of contract time or alteration of the bid documents. Such qualifications will be due within ten (10) days of receipt of notification of subcontractor rejection. Failure to submit an acceptable alternate subcontractor may result in rejection of the bid. In this event, the bid bond shall be returned to Contractor without claim by the City and with forfeiture of all claim rights by the Contractor.

**3.5 Deliverables and Objectives**

Refer to Attachment B General Conditions Public Utilities, Attachment C Supplementary General Conditions, Attachment D Technical Specifications and Attachment E Drawings.

**3.6 Project Schedule / Timeline**

Refer to Attachment C, Supplementary conditions, Section 1, Project Schedule.

**3.7 Questions**

Refer to Form 15, Information Required from Bidders.

**3.8 Substantial Completion**

Refer to Attachment C, Supplementary conditions, Section 1, Project Schedule.

*END OF SECTION*

## **SECTION IV – GENERAL TERMS AND CONDITIONS**

### **1.1 INTENT**

It is the policy of the City to encourage full and open competition among all available qualified vendors. All vendors regularly engaged in the type of Work specified in the Bid Solicitation are encouraged to submit bids. To receive notification and to be eligible to bid vendor should be registered with OpenGov. Vendors may register with the OpenGov (registration is free) to be included on a mailing list for selected categories of goods and Services. In order to be processed for payment, any awarded vendor must register with the City by completing and returning a Vendor Application and all supporting documents. For information and to apply as a vendor, please visit our website at [hollywoodfl.org](http://hollywoodfl.org) to download an application and submit it to Procurement Services Division.

It is the intent of the City of Hollywood, FL ("the City"), through this solicitation and the contract conditions contained herein, to establish to the greatest possible extent complete clarity regarding the requirements of both parties to the agreement resulting from this solicitation.

Before submitting a bid, the Vendor shall be thoroughly familiarized with all contract conditions referred to in this document and any addenda issued before the bid/proposal submission date. Such addenda shall form a part of the SOLICITATION and shall be made a part of the contract. It shall be the Vendor's responsibility to ascertain that the bid/proposal includes all addenda issued prior to the bid/proposal submission date. Addenda will be posted on the City's internet site along with the SOLICITATION.

The terms of the SOLICITATION and the selected Vendor's bid and any additional documentation (e.g. questions and answers) provided by the Vendor during the solicitation process will be integrated into the final contract for services entered into between the City and the selected Vendor. The Vendor shall determine, by personal examination and by such other means as may be preferred, the conditions and requirements under which the agreement must be performed.

### **1.2 PROPOSER'S RESPONSIBILITIES**

Proposers are required to submit their bids upon the following express conditions:

- A. Proposers shall thoroughly examine the drawings, specifications, schedules, instructions and all other contract documents.
- B. Proposers shall make all investigations necessary to thoroughly inform themselves regarding delivery of material, equipment or services as required by the SOLICITATION conditions. No plea of ignorance, by the proposer, of conditions that exist or that may hereafter exist as a result of failure or omission on the part of the proposer to make the necessary examinations and investigations, or failure to fulfill in every detail the requirements of the contract documents, will be accepted as a basis for varying the requirements of the City or the compensation due the proposer.
- C. Proposers are advised that all City contracts are subject to all legal requirements provided for in the City of Hollywood Charter, Code of Ordinances and applicable County Ordinances, State Statutes and Federal Statutes.

### **1.3 PREPARATION OF BIDS/PROPOSALS**

Bids/proposals shall be prepared in accordance with the bid/proposal response format. Bids/proposals not complying with this format may be considered non-responsive and may be removed from consideration on this basis. Each proposer, by making a bid/proposal, represents that this document has been read and is fully understood.

Bids/proposals will be prepared in accordance with the following:

- A. The City's enclosed bid/proposal Forms, in their entirety, are to be used in submitting your bid/proposal. **NO OTHER FORM WILL BE ACCEPTED.**
- B. All information required by the bid/proposal form shall be furnished. The proposer shall sign each continuation sheet (where indicated) on which an entry is made.

C. Prices shall be shown and where there is an error in extension of prices, the unit price shall govern.

The City of Hollywood is exempt from payment to its vendors of State of Florida sales tax and, therefore, such taxes should not be figured into the SOLICITATION. However, this exemption does not apply to suppliers to the City in their (supplier) purchases of goods or services, used in work or goods supplied to the City. Proposers are responsible for any taxes, sales or otherwise, levied on their purchases, subcontracts, employment, etc. An exemption certificate will be signed where applicable, upon request. The City will pay no sales tax.

#### **1.4 DESCRIPTION OF SUPPLIES (As Applicable)**

Any manufacturer's names, trade names, brand names, or catalog numbers used in these applications are for the purpose of describing and establishing minimum requirements or level of quality, standards of performance, and design required, and are in no way intended to prohibit the bidding of other manufacturers' items of equal material, unless specifications state "NO SUBSTITUTIONS."

Proposers must indicate any variances to the specifications, terms, and conditions, no matter how slight. If variations are not stated in the bid/proposal, it shall be construed that the bid/proposal fully complies with the Specifications, Terms and Conditions.

Proposers are required to state exactly what they intend to furnish; otherwise they shall be required to furnish the items as specified.

Proposers will submit, with their bid/proposal, necessary data (factory information sheets, specifications, brochures, etc.) to evaluate and determine the quality of the item(s) they are proposing.

The City shall be the sole judge of equality and its decision shall be final.

#### **1.5 ADDENDA**

The Procurement Services Division may issue an addendum in response to any inquiry received, prior to bid/proposal opening, which changes, adds to or clarifies the terms, provisions or requirements of the solicitation. The Proposer should not rely on any representation, statement or explanation, whether written or verbal, other than those made in this solicitation document or in any addenda issued. Where there appears to be a conflict between this solicitation and any addendum, the last addendum issued shall prevail. It is the proposer's responsibility to ensure receipt of all addenda and any accompanying documents. Proposer(s) shall acknowledge receipt of any formal Addenda by signing the addendum and including it with their bid/proposal. Failure to include signed formal addenda in its bid/proposal shall cause the City to deem the bid/proposal non-responsive provided, however, that the City may waive this requirement in its best interest.

#### **1.6 REJECTION OF BIDS/PROPOSALS**

To the extent permitted by applicable state and federal laws and regulations, the City reserves the right to reject any and all bids/proposals, to waive any and all informalities, irregularities and technicalities not involving price, time or changes in the commodities and/or services, and the right to disregard all nonconforming, non-responsive, unbalanced or conditional bids/proposals. Bids/proposals will be considered irregular and may be rejected if they show serious omissions, alterations in form, additions not called for, conditions or unauthorized alterations or irregularities of any kind.

The City also reserves the right to waive minor technical defects in a bid/proposal. The City reserves the right to determine, in its sole discretion, whether any aspect of a bid/proposal satisfies the criteria established in this Solicitation.

The City reserves the right to reject, in whole or in part, the bid/proposal of any Proposer if the City believes that it would not be in the best interest of the City to make an award to that Proposer, whether because the bid/proposal is not responsive or the Proposer is unqualified or of doubtful financial ability or fails to meet any other pertinent standard or criterion established by City.

The foregoing reasons for rejection of bids/proposals are not intended to be exhaustive.

The City may reject a bid/proposal if:

A. The Proposer fails to acknowledge receipt of an addendum, or if



- B. The Proposer misstates or conceals any material fact in the bid/proposal, or if
- C. The bid/proposal does not strictly conform to the law or requirements of the SOLICITATION, or if
- D. The City is under a pre- lawsuit claim or current litigation with the proposer.

Additionally, any one of the following causes (not limited to) may be considered as sufficient justification to disqualify a Bidder and reject his/her Bid:

- A. Submission of more than one Bid for the same work by an individual, firm, partnership or corporation under the same or different names.
- B. Evidence of collusion.
- C. Previous participation in collusive Bidding on work for the City of Hollywood, Florida.
- D. Submission of an unbalanced Bid in which the prices Bid for some items are out of proportion to the prices Bid for other items.
- E. Lack of competency. The Engineer may declare any Bidder ineligible, at any time during the process or receiving Bids or awarding the Contract, if developments arise which, in his opinion, adversely affects the Bidder's responsibility. The Bidder will be given an opportunity, by the Engineer, to present additional evidence before final action is taken.
- F. Lack of responsibility as shown by past work judged by the Engineer from the standpoint of workmanship and progress.
- G. Uncompleted work for which the Bidder is committed by Contract, which is in the judgment of the Engineer, might hinder or prevent the prompt completion of work under this Contract

The City may reject all bids whenever it is deemed in the best interest of the City to do so, and may reject any part of a bid unless the bid has been qualified as provided in herein.

#### **1.7 WITHDRAWAL OF BIDS**

- A. Bids may not be withdrawn and shall be deemed enforceable for a period of 180 days after the time set for the SOLICITATION opening.
- B. Bids may be withdrawn prior to the time set for the SOLICITATION opening. Such request must be in writing.
- C. The City will permanently retain as liquidated damages and the bid deposit furnished by any Bidder who requests to withdraw a bid after the SOLICITATION opening.

#### **1.8 BIDS TO REMAIN OPEN**

All bids shall remain open for 180 calendar days after the day of the bid opening, but the City may, at its sole discretion, release any bid and return the bid Security prior to that date.

Extensions of time when bids shall remain open beyond the 180 day period may be made only by mutual written agreement between the City, the successful Bidder and the surety, if any, for the successful Bidder.

#### **1.9 LATE BIDS OR MODIFICATIONS**

Only bids received as of the opening date and time will be considered timely. Bids and modifications received after the time set for the opening will be returned un-opened to the sender and rejected as late.

#### **1.10 CONFLICTS WITHIN THE SOLICITATION**

Where there appears to be a conflict between the General Terms and Conditions, Special Conditions, the Technical Specifications, the SOLICITATION Submittal Section, or any addendum issued, the order of precedence shall be the last addendum issued, the SOLICITATION Submittal Section, the Technical Specifications, the Special Conditions, and then the General Terms and Conditions.

#### **1.11 CLARIFICATION OR OBJECTION TO BID SPECIFICATIONS**

If any person contemplating submitting a bid for this contract is in doubt as to the true meaning of the specifications or other SOLICITATION documents or any part thereof, they may submit requests for clarification to the Procurement Services Division on or before the date specified for a request for clarification. All such requests for clarification shall be made in writing and the person submitting the request will be responsible for its prompt delivery. Any interpretation of the SOLICITATION, if made, will be made only by Addendum duly issued. A copy of such Addendum will be made available to each person receiving a Solicitation. The City will not be responsible for any other explanation or interpretation of the SOLICITATION given prior to the award of the contract. Any objection to the specifications and requirements as set forth in this SOLICITATION must be filed in writing with the Chief Procurement Officer on or before the date specified for a request for clarification.

#### **1.12 COMPETENCY OF PROPOSERS**

Pre-award inspection of the Bidder's facility may be made prior to the award of a contract. Bids will be considered only from firms which are regularly engaged in the business of providing the goods and/or services as described in this SOLICITATION(s); have a record of performance for a reasonable period of time; and have sufficient financial support, equipment and organization to ensure that they can satisfactorily deliver the material and/or services if awarded a Contract under the terms and conditions herein stated. The terms "equipment and organization" as used herein shall be construed to mean a fully equipped and well established company in line with the best business practices in the industry and as determined by the proper authorities of the City.

The City may consider any evidence available to it of the financial, technical and other qualifications and abilities of a proposer, including past performance (experience) in making the award in the best interest of the City. In all cases the City of Hollywood shall have no liability to any proposer for any costs or expense incurred in connection with this SOLICITATION or otherwise.

#### **1.13 QUALIFICATIONS OF PROPOSERS**

No Bid will be accepted from, nor will any contract be awarded to any person who is in arrears to the City upon any debt or contract, or who is a defaulter, as surety or otherwise, upon any obligation to City, or who is deemed responsible or unreliable by the City.

As part of the bid evaluation process, City may conduct a background investigation including a record check by the Hollywood Police Department. Proposer's submission of a bid constitutes acknowledgment of the process and consent to such investigation. City shall be the sole judge in determining a Bidder's qualifications.

#### **1.14 CONSIDERATION OF BIDS**

In cases where an item requested is identified by a manufacturer's name, trade name, catalog number, or reference, it is understood that the Vendor proposes to furnish the item so identified and does not propose to furnish an "equal" unless the proposed "equal" is pre-approved by the City.

References to any of the above are intended to be descriptive but not restrictive and only indicate articles that will be satisfactory. A bid of an "equal" will be considered, provided that the Vendor states in his bid exactly what he proposes to furnish, including sample, illustration, or other descriptive matter which will clearly indicate the character of the article covered by such bid. The designated City representative hereby reserves the right to approve as an "equal", or to reject as not being an "equal", any article proposed which contains major or minor variations from specifications requirements.

#### **1.15 AWARD OF CONTRACT**

If the Contract is to be awarded, it will be awarded, after evaluation by the City, to the responsible and responsive Proposer whom the City determines will be in the best interests of the City and not necessarily to the lowest cost Proposer. Proposers may be invited to an oral interview before the committee. A short list of finalists will be determined and presented to either the City Manager or his/her designee or to the City Commission, in accordance with the applicable City of Hollywood Code of Ordinances, and will make the final ranking for the purposes of negotiating a contract with the top ranked firm. The successful Proposer shall be required to sign a negotiated contract; the refusal or failure of a successful Proposer to execute a contract which contains the mandatory material terms and conditions contained in the SOLICITATION, shall be grounds for deeming the Proposer and/or the Proposer's bid/proposal non-responsive.

If applicable, the Proposer to whom award is made shall execute a written contract prior to award by the City Commission. If the Proposer to whom the first award is made fails to enter into a contract as herein provided, the Contract may be let to the next highest ranked Proposer who is responsible and responsive in the opinion of the City.

#### **1.16 BASIS FOR AWARD, EVALUATION CRITERIA AND QUESTIONS**

The qualification of bid/proposal responders on this project will be considered in making the award. The City is not obligated to accept any bid/proposal if deemed not in the best interest of the City to do so. The City shall make award to a qualified proposer based on fees submitted and responses to this SOLICITATION.

Failure to include in the bid all information outlined herein may be cause for rejection of the bid.

The City reserves the right to accept or reject any and all bids, in whole or in part, as determined to be in the best interest of the City in its sole discretion.

The City reserves the right to waive any informalities or irregularities in bids.

The City reserves the right to negotiate separately the terms and conditions or all or any part of the bids as deemed to be in the City's best interest in its sole discretion.

Information and/or factors gathered during interviews, negotiations and any reference checks, and any other information or factors deemed relevant by the City, shall be utilized in the final award. The final award of a contract is subject to approval by the City Commission.

#### **1.17 AGREEMENT**

An agreement shall be sent to the awarded proposer to be signed, witnessed, and returned to the City for execution. The City will provide a copy of the fully executed agreement to the awarded proposer.

#### **1.18 NOTICE TO PROCEED**

A signed purchase order, blanket purchase order or fully executed agreement will be the Proposer's authorization to proceed and may substitute for a "Notice to Proceed" form.

#### **1.19 BID PROTESTS**

The City shall provide notice of its intent to award or reject to all Proposers by posting such notice on the City's website.

After a notice of intent to award a contract is posted, any actual or prospective proposer who is aggrieved in connection with the pending award of the contract or any element of the process leading to the award of the contract may protest to the Director of Procurement Services. A protest must be filed within five business days after posting or any right to protest is forfeited. The protest must be in writing, must identify the name and address of the protester, and must include a factual summary of, and the basis for, the protest. Filing shall be considered complete when the protest, including a deposit, is received by the Procurement Services Division. Failure to file a protest within the time-frame specified herein shall constitute a full waiver of all rights to protest the City's decision regarding the award.

The written protest shall state in detail the specific facts and law or ordinance upon which the protest of the proposed award is based, and shall include all pertinent documents.

A written protest may not challenge the relative weight of evaluation criteria or a formula for assigning points.

Upon receipt of a formal written protest, the City shall stop award proceedings until resolution of the protest; unless it has been determined that the award of the contract without delay is necessary to protect substantial interests of the City.

Any and all costs incurred by a protesting party in connection with a bid protest shall be the sole responsibility of the protesting party.

Upon receipt of a protest of the pending award of a contract, a copy of the protest shall promptly be forwarded to the City Attorney. The City Attorney shall thereupon review the charge to determine its sufficiency, including whether the protest was timely filed. If upon review the City Attorney determines that the charge is insufficient, the City Attorney may issue a

summary dismissal of the protest. If upon review the City Attorney determines that the charge is sufficient, a hearing of the protest committee shall be scheduled.

A protest committee shall have the authority to review, settle and resolve the protest. The committee shall consist of three members appointed by the City Manager. The committee's review shall be informal.

If the protest committee determines that the pending award of a contract or any element of the process leading to the award involved a significant violation of law or applicable rule or regulation, all steps necessary and proper to correct the violation shall be taken. If the committee determines that the protest is without merit,

The Director shall promptly issue a decision in writing stating the reason for the decision and furnish a copy to the protester and any other interested party, and the process leading to the award shall proceed.

## **1.20 REQUIREMENTS FOR SIGNING BIDS/PROPOSALS**

Requirements for Signing Bid/Proposal:

- A. The bid/proposal must be signed in ink by an individual authorized to legally bind the person, partnership, company, or corporation submitting the bid/proposal. In cases where the bid/proposal is signed by a deputy or subordinate, the principal's proper written grant of authority to such deputy or subordinate must accompany the bid/proposal.
- B. Bids/proposals by corporations must be executed in the corporate name by the President or other corporate officers accompanied by evidence of authority to sign. The corporate address and state of incorporation must be shown below the signature.
- C. Bids/proposals by partnerships must be executed in the partnership name and signed by a general partner whose title must appear under the signature and the official address of the partnership must be shown below the signature.
- D. All manual signatures must have the name typed directly under the line of the signature
- E. The above requirements apply to all SOLICITATION addenda.

## **1.21 EXAMINATION OF BID DOCUMENTS**

Before submitting a bid, each Bidder must: examine the bid Documents thoroughly; consider federal, state and local laws, ordinances, rules and regulations that may in any manner affect cost, progress, performance, or provision of the commodities and/or services; study and carefully correlate Proposer's observations with the bid Documents, and notify the City's agent of all conflicts, errors and discrepancies in the bid Documents.

The submission of a bid/proposal will constitute an incontrovertible representation by the Bidder, that the Bidder has complied with every requirement of this SOLICITATION, that without exception, the bid is premised upon performing the services and/or furnishing the commodities and materials in accordance with such means, methods, techniques, sequences or procedures as may be indicated in or required by the bid/proposal Documents, and that the bid Documents are sufficient in scope and detail to indicate and convey understanding of all terms and conditions of performance and furnishing of the goods and/or services.

## **1.22 PUBLIC RECORDS LAW**

If applicable, for each public agency contract for services, the Proposer is required to comply with F.S. 119.0701, which includes the following:

- A. Keep and maintain public records that ordinarily and necessarily would be required by the public agency in order to perform the service.
- B. Provide the public with access to public records on the same terms and conditions that the public agency would provide the records and at a cost that does not exceed the cost provided in F.S. Chapter 119 or as otherwise provided by law.

- C. Ensure that public records that are exempt or confidential and exempt from public records disclosure requirements are not disclosed except as authorized by law.
- D. Meet all requirements for retaining public records and transfer, at no cost, to the public agency, all public records in possession of the proposer upon termination of the contract and destroy any duplicate public records that are exempt or confidential and exempt from public records disclosure requirements. All records stored electronically must be provided to the public agency in a format that is compatible with the information technology systems of the public agency.

Public records may be inspected and examined by anyone desiring to do so, at a reasonable time, under reasonable conditions, and under supervision by the custodian of the public record. Sealed Bids become subject to the public records disclosure requirements of F.S. Chapter 119, notwithstanding a proposers' request to the contrary, at the time the City provides notice of a decision or intended decision, or 30 days after the bid/proposal opening, whichever is earlier.

Financial statements submitted in response to a request by the City may be confidential and exempt from disclosure.

Data processing software obtained under a licensing agreement which prohibits its disclosure may also exempt.

Proposers are hereby notified and agree that all information submitted as part of, or in support of SOLICITATION submittals will be available for public inspection after opening of SOLICITATION in compliance with Chapter 119 of the Florida Statutes. The proposer shall not, unless required as part of this SOLICITATION, submit any information in response to this invitation which the proposer considers to be a trade secret, proprietary or confidential. The submission, not required as part of this this SOLICITATION, of any information to the City in connection with this invitation shall be deemed conclusively to be a waiver of any trade secret or other protection, which would otherwise be available to the proposer.

### **1.23 INFORMATION**

For information concerning procedure for responding to this Solicitation (SOLICITATION), contact the Point of Contact in the Section 1.4. Such contact shall be for clarification purposes only. **It is preferred that all other questions be submitted in writing via OpenGov at least 10 calendar days prior to the bid/proposal due/opening date.**

### **1.24 N/A – INTENTIONALLY OMITTED**

### **1.25 MODIFICATION AND WITHDRAWAL OF BIDS/PROPOSALS**

Bids must be modified or withdrawn by an appropriate document duly executed in the manner that a bid must be executed and delivered to the place where bids are to be submitted at any time prior to the deadline for submitting bids. A request for withdrawal or a modification must be in writing and signed by a person duly authorized to do so and, in a case where signed by a deputy or subordinate, the principal's proper written grant of authority to such deputy or subordinate must accompany the request for withdrawal or modification. Withdrawal of a bid will not prejudice the rights of a Bidder to submit a new bid prior to the bid date and time. Except where provided in the following paragraph no bid may be withdrawn or modified after expiration of the period for receiving bids.

If, within twenty-four (24) hours after bids are opened, any Bidder files a duly signed written notice with the City and within five (5) calendar days thereafter demonstrates to the reasonable satisfaction of the City by clear and convincing evidence that there was a material and substantial mistake in the preparation of its bid, or that the mistake is clearly evident on the face of the bid but the intended correct bid is not similarly evident, then the Bidder may withdraw its bid and the bid Security will be returned.

### **1.26 N/A – INTENTIONALLY OMITTED**

### **1.27 OPEN END CONTRACT**

No guarantee is expressed or implied as to the total quantity of commodities/services to be purchased under any open end contract. Estimated quantities will be used for bid comparison purposes only. The City reserves the right to issue purchase orders as and when required, or a blanket purchase order and release partial quantities as and when required or any combination of the preceding.

ORDERING: The CITY reserves the right to purchase commodities/services specified herein through Contracts established by other governmental agencies or through separate procurement actions due to unique or special needs. If an urgent

delivery is required within a period shorter than the delivery time specified in the contract, and if the seller is unable to comply therewith, the City reserves the right to obtain such delivery from others without penalty or prejudice to the City or to the Bidder.

### **1.28 AUDIT RIGHTS**

The City reserves the right to audit the records of the successful Bidder for the commodities and/or services provided under the Contract at any time during the performance and term of the Contract and for a period of three (3) years after completion and acceptance by the City. If required by the City, the successful Bidder agrees to submit to an audit by an independent certified public accountant selected by the City. The successful Bidder shall allow the City to inspect, examine and review the records of the successful Bidder in relation to this contract at any and all times during normal business hours during the term of the Contract.

### **1.29 LOCAL, STATE AND FEDERAL COMPLIANCE REQUIREMENTS**

The Bidder shall comply with all local, state and federal directives, orders and laws as applicable to this SOLICITATION and subsequent contract(s) including, but not limited to:

- A. Equal Employment Opportunity (EEO), in compliance with Executive Order 11246 as amended and applicable to this contract.
- B. All manufactured items and fabricated assemblies shall comply with applicable requirements of the Occupation Safety and Health Act of 1970 as amended, and be in compliance with Chapter 442, Florida Statutes. Any toxic substance listed in Section 38F-41.03 of the Florida Administrative Code delivered as a result of this order must be accompanied by a completed Material Safety Data Sheet (MSDS).
- C. The Immigration and Nationality Act prohibits (i) the employment of an unauthorized alien when the employer knows the individual is an unauthorized alien and (ii) the employment of an individual without complying with the requirements of the federal employment verification system. If a proposer commits either of these violations, such violation shall be cause for unilateral cancellation of the contract.
- D. This Section applies only to any contract for goods or services of \$1 million or more: The Proposer certifies that it is not on the Scrutinized Companies with Activities in Sudan List or the Scrutinized Companies with Activities in the Iran Petroleum Energy Sector List and that it does not have business operations in Cuba or Syria as provided in section 287.135, Florida Statutes (2011), as may be amended or revised. The City may terminate this Contract at the City's option if the Proposer is found to have submitted a false certification as provided under subsection (5) of section 287.135, Florida Statutes (2011), as may be amended or revised, or been placed on the Scrutinized Companies with Activities in Sudan List or the Scrutinized Companies with Activities in the Iran Petroleum Energy Sector List or has engaged in business operations in Cuba or Syria, as defined in Section 287.135, Florida Statutes (2011), as may be amended or revised.

### **1.30 FRAUD AND MISREPRESENTATION**

Any individual, corporation or other entity that attempts to meet its contractual obligations with the City through fraud, misrepresentation or material misstatement, may be debarred from doing business with the City. The City as further sanction may terminate or cancel any other contracts with such individual, corporation or entity. Such individual or entity shall be responsible for all direct or indirect costs associated with termination or cancellation, including attorney's fees.

### **1.31 DEBARRED OR SUSPENDED BIDDERS**

The bidder certifies, by submission of a response to this solicitation, that neither it nor its principals and sub bidder are presently debarred or suspended by any Federal department or agency.

### **1.32 COLLUSION**

More than one bid/proposal received for the same work from an individual, firm, partnership, corporation or association under the same or different names will not be considered. Reasonable grounds for believing that any Bidder is interested in more than one bid for the same work will cause the rejection of such bid which the Bidder is interested. If there are reasonable grounds for believing that collusion exists among the Bidder, the bids of participants in such collusion will not be considered.

### **1.33 COPELAND "ANTI-KICKBACK"**

The Bidder and all sub bidders will comply with the Copeland Anti-Kickback Act (18 U.S.C. 874) as supplemented in Department of Labor regulations (29 CFR Part 3).

### **1.34 FORCE MAJEURE**

The Agreement which is awarded to the successful proposer may provide that the performance of any act by the City or Bidder hereunder may be delayed or suspended at any time while, but only so long as, either party is hindered in or prevented from performance by acts of God, the elements, war, rebellion, strikes, lockouts or any cause beyond the reasonable control of such party, provided however, the City shall have the right to provide substitute service from third parties or City forces and in such event the City shall withhold payment due the Bidder for such period of time. If the condition of force majeure exceeds a period of 14 days the City may, at its option and discretion, cancel or renegotiate this Agreement.

### **1.35 PUBLIC ENTITY CRIMES**

A person or affiliate who has been placed on the convicted vendor list following a conviction for a public entity crime may not submit a bid on a contract to provide any goods or services to a public entity, may not submit a bid on a contract with a public entity for the construction or repair of a public building or public work, may not submit bids on leases of real property to a public entity, may not be awarded or perform work as a Bidder, supplier, sub bidder, or consultant under a contract with any public entity, and may not transact business with any public entity in excess of the threshold amount provided in Florida Statutes, Section 287.017, for CATEGORY TWO for a period of 36 months from the date of being placed on the convicted vendor list.

### **1.36 DRUG-FREE WORKPLACE PROGRAM**

Preference shall be given to businesses with drug-free workplace programs. Whenever two or more bids which are equal with respect to price, quality, and service are received by the State or by any political subdivision for the procurement of commodities or contractual services, a bid received from a business that certifies that it has implemented a drug-free workplace program shall be given preference in the award process. Established procedures for processing tie bids will be followed if none of the tied vendors have a drug-free workplace program.

### **1.37 SOLICITATION, GIVING, AND ACCEPTANCE OF GIFTS POLICY**

Bidder shall sign and submit the attached form indicating understanding and compliance with the City's and State's policies prohibiting solicitation and acceptance of gifts by public officers, employees and candidates. Failure to submit the signed form will result in your bid being declared non-responsive; provided, however, that a responsible Bidder whose bid would be responsive but for the failure to submit the signed form in its bid may be given the opportunity to submit the form to the City within five calendar days after notification by the City, if this is determined to be in the best interest of the City.

### **1.38 CONFLICT OF INTEREST**

The Bidder represents that:

No officer, director, employee, agent, or other consultant of the City or a member of the immediate family or household of the aforesaid has directly or indirectly received or been promised any form of benefit, payment or compensation, whether tangible or intangible, in connection with the grant of this Agreement.

There are no undisclosed persons or entities interested with the Proposer in this Agreement. This Agreement is entered into by the Proposer without any connection with any other entity or person making a bid Bidder for the same purpose, and without collusion, fraud or conflict of interest. No elected or appointed officer or official, director, employee, agent or other consultant of the City, or of the State of Florida (including elected and appointed members of the legislative and executive branches of government), or member of the immediate family or household of any of the aforesaid:

1. Is interested on behalf of or through the Bidder directly or indirectly in any manner whatsoever in the execution or the performance of this Agreement, or in the services, supplies or work, to which this Agreement relates or in any portion of the revenues; or

2. Is an employee, agent, advisor, or consultant to the Proposer or to the best of the Proposer's knowledge, any sub bidder or supplier to the Bidder.

Neither the Bidder nor any officer, director, employee, agent, parent, subsidiary, or affiliate of the Bidder shall have an interest which is in conflict with the Bidder's faithful performance of its obligations under this Agreement; provided that the City, in its sole discretion, may consent in writing to such a relationship, and provided the Bidder provides the City with a written notice, in advance, which identifies all the individuals and entities involved and sets forth in detail the nature of the relationship and why it is in the City's best interest to consent to such relationship.

The provisions of this Article are supplemental to, not in lieu of, all applicable laws with respect to conflict of interest. In the event there is a difference between the standards applicable under this Agreement and those provided by statute, the stricter standard shall apply.

In the event the Bidder has no prior knowledge of a conflict of interest as set forth above and acquires information which may indicate that there may be an actual or apparent violation of any of the above, the Bidder shall promptly bring such information to the attention of the City's ENGINEER. The Bidder shall thereafter cooperate with the City's review and investigation of such information, and comply with the instructions the Bidder receives from the ENGINEER in regard to remedying the situation.

#### **1.39 DISCRIMINATION**

Any entity or affiliate who has been placed on the discriminatory vendor list may not submit a bid on a contract to provide goods or services to a public entity, may not submit a bid on a contract with a public entity for construction or repair of a public building or public work, may not submit bids on leases of real property to a public entity, may not award or perform work as a proposer, supplier, sub bidder, or consultant under contract with any public entity, and may not transact business with any public entity.

#### **1.40 ADVICE OF OMISSION OR MISSTATEMENT**

In the event it is evident to a Vendor responding to this SOLICITATION that the City has omitted or misstated a material requirement to this SOLICITATION and/or the services required by this SOLICITATION, the responding Vendor shall advise the contact identified in the SOLICITATION Clarifications and Questions section above of such omission or misstatement.

#### **1.41 CONFIDENTIAL INFORMATION**

Information contained in the Vendor's bid that is company confidential must be clearly identified in the bid/proposal itself. The City will be free to use all information in the Vendor's bid for the City's purposes, in accordance with State Law. Vendor bids shall remain confidential for 30 days or until a notice of intent to award is posted, which is sooner. The Vendor understands that any material supplied to the City may be subject to public disclosure under the Public Records Law.

#### **1.42 GOVERNING LAW**

This Contract, including appendices, and all matters relating to this Contract (whether in contract, statute, tort (such as negligence), or otherwise) shall be governed by, and construed in accordance with, the laws of the State of Florida. This shall apply notwithstanding such factors which include, but are not limited to, the place where the contract is entered into, the place where the accident occurs and notwithstanding application of conflicts of law principles.

#### **1.43 LITIGATION VENUE**

The parties waive the privilege of venue and agree that all litigation between them in the state courts shall take place in Broward County, Florida and that all litigation between them in the federal courts shall take place in the Southern District of Florida.

#### **1.44 SOVEREIGN IMMUNITY**

Nothing in this agreement shall be interpreted or construed to mean that the city waives its common law sovereign immunity or the limits of liability set forth in Section 768.28, Florida Statute.



#### **1.45 SURVIVAL**

The parties acknowledge that any of the obligations in this Agreement will survive the term, termination and cancellation hereof. Accordingly, the respective obligations of the Proposer and the City under this Agreement, which by nature would continue beyond the termination, cancellation or expiration thereof, shall survive termination, cancellation or expiration hereof.

#### **1.46 INDEMNIFICATION AND HOLD HARMLESS AGREEMENT**

The Contractor shall indemnify and hold harmless the City of Hollywood and its officers, employees, agents and instrumentalities from any and all liability, losses or damages. In addition, the City shall be entitled to attorney's fees and costs of defense, which the City of Hollywood, or its officers, employees, agents or instrumentalities may incur as a result of claims, demands, suits, causes of actions or proceedings of any kind or nature arising out of, relating to or resulting from the performance of this project by the awarded Bidder or its employees, agents, servants, partners, principals or subcontractors. Furthermore, the awarded Bidder shall pay all claims and losses in connection therewith and shall investigate and defend all claims, suits or actions of any kind of nature in the name of the City of Hollywood, where applicable, including appellate proceedings, and shall pay all costs, judgments, and attorney's fees which may issue thereon. The awarded Bidder expressly understands and agrees that any insurance protection required by the resulting agreement or otherwise provided by the awarded Bidder shall cover the City of Hollywood, its officers, employees, agents and instrumentalities and shall include claims for damages resulting from and/or caused by the negligence, recklessness or intentional wrongful misconduct of the Contractor and persons employed by or utilized by the Contractor in the performance of the contract.

#### **1.47 PATENT AND COPYRIGHT INDEMNIFICATION**

The Bidder warrants that all deliverables furnished hereunder, including but not limited to: services, equipment programs, documentation, software, analyses, applications, methods, ways, processes, and the like, do not infringe upon or violate any patent, copyrights, service marks, trade secret, or any other third party proprietary rights.

The Bidder shall be liable and responsible for any and all claims made against the City for infringement of patents, copyrights, service marks, trade secrets or any other third party proprietary rights, by the use or supplying of any programs, documentation, software, analyses, applications, methods, ways, processes, and the like, in the course of performance or completion of, or in any way connected with, the work, or the City's continued use of the deliverables furnished hereunder. Accordingly, the Bidder, at its own expense, including the payment of attorney's fees, shall indemnify, and hold harmless the City and defend any action brought against the City with respect to any claim, demand, and cause of action, debt, or liability.

In the event any deliverable or anything provided to the City hereunder, or a portion thereof, is held to constitute an infringement and its use is or may be enjoined, the Bidder shall have the obligation, at the City's option, to (i) modify, or require that the applicable sub bidder or supplier modify, the alleged infringing item(s) at the Bidder's expense, without impairing in any respect the functionality or performance of the item(s), or (ii) procure for the City, at the Bidder's expense, the rights provided under this Agreement to use the item(s).

The Bidder shall be solely responsible for determining and informing the City whether a prospective supplier or sub bidder is a party to any litigation involving patent or copyright infringement, service mark, trademark, violation, or proprietary rights claims or is subject to any injunction which may prohibit it from providing any deliverable hereunder. The Bidder shall enter into agreements with all suppliers and sub bidder at the Bidder's own risk. The City may reject any deliverable that it believes to be the subject of any such litigation or injunction, or if, in the City's judgment, use thereof would delay the work or be unlawful.

The Bidder shall not infringe any copyright, trademark, service mark, trade secrets, patent rights, or other intellectual property rights in the performance of the work.

#### **1.48 ADVERTISING**

Vendor shall not advertise or publish the fact that the City has placed this order without prior written consent from the City, except as may be necessary to comply with a proper request for information from an authorized representative of a governmental unit or agency.

#### **1.49 DISCLAIMER**

The Hollywood may, in its sole discretion, accept or reject, in whole or in part, for any reason whatsoever any or all bids; re-advertise this SOLICITATION, postpone or cancel at any time this SOLICITATION process; or, waive any formalities of or irregularities in the bid process. Bids that are not submitted on time and/or do not conform to the City of Hollywood's requirements will not be considered. After all bids are analyzed, organization(s) submitting bid that appear, solely in the opinion of the City of Hollywood, to be the most competitive, shall be submitted to the City of Hollywood's City Commission, and the final selection will be made shortly thereafter with a timetable set solely by the City of Hollywood. The selection by the City of Hollywood shall be based on the bid, which is, in the sole opinion of the City Commission of the City of Hollywood, in the best interest of the City of Hollywood. The issuance of this SOLICITATION constitutes only an invitation to make a bid to the City of Hollywood. The City of Hollywood reserves the right to determine, in its sole discretion, whether any aspect of the bid satisfies the criteria established by the City. In all cases the City of Hollywood shall have no liability to any proposer for any costs or expense incurred in connection with this bid or otherwise.

#### **1.50 TRADEMARKS**

The City warrants that all trademarks the City requests the Vendor to affix to articles purchased are those owned by the City and it is understood that the Vendor shall not acquire or claim any rights, title, or interest therein, or use any of such trademarks on any articles produced for itself or anyone other than the City.

#### **1.51 RIGHT TO REQUEST ADDITIONAL INFORMATION**

The City reserves the right to request any additional information that might be deemed necessary during the evaluation process.

#### **1.52 BID PREPARATION COSTS**

The Vendor is responsible for any and all costs incurred by the Vendor or his/her sub bidders in responding to this solicitation.

#### **1.53 DESIGN COSTS (N/A)**

#### **1.54 ADDITIONAL CHARGES**

No additional charges, other than those listed on the price breakdown sheets, shall be made. Prices quoted will include verification/coordination of order, all costs for shipping, delivery to all sites, unpacking, setup, installation, operation, testing, cleanup, training and Vendor travel charges.

#### **1.55 RIGHTS TO PERTINENT MATERIALS**

All responses, inquires, and correspondence relating to this SOLICITATION and all reports, charts, displays, schedules, exhibits and other documentation produced by the Vendor that are submitted as part of the bid shall become the property of the City upon receipt, a part of a public record upon opening, and will not be returned.

#### **1.56 INSURANCE REQUIREMENTS**

See insurance requirements in the main solicitation document.

#### **1.57 NATURE OF THE AGREEMENT**

The Agreement incorporates and includes all negotiations, correspondence, conversations, agreements, and understandings applicable to the matters contained in the Agreement. The parties agree that there are no commitments, agreements, or understandings concerning the subject matter of the Agreement that are not contained in the Agreement, and that the Agreement contains the entire agreement between the parties as to all matters contained herein. Accordingly, it is agreed that no deviation from the terms hereof shall be predicated upon any prior representations or agreements, whether oral or written. It is further agreed that any oral representations or modifications concerning this Agreement shall be of no force or effect, and that the Agreement may be modified, altered or amended only by a written amendment duly executed by both parties hereto or their authorized representatives.

The Bidder shall provide the services set forth in the Scope of Services, and render full and prompt cooperation with the City in all aspects of the services performed hereunder.

The Bidder acknowledges that the Agreement requires the performance of all things necessary for or incidental to the effective and complete performance of all work and services under this Contract. All things not expressly mentioned in the Agreement but necessary to carrying out its intent are required by the Agreement, and the Bidder shall perform the same as though they were specifically mentioned, described and delineated.

The Bidder shall furnish all labor, materials, tools, supplies, and other items required to perform the work and services that are necessary for the completion of this Contract. All work and services shall be accomplished at the direction of and to the satisfaction of the City's ENGINEER.

The Bidder acknowledges that the City shall be responsible for making all policy decisions regarding the Scope of Services. The Proposer agrees to provide input on policy issues in the form of recommendations.

The Bidder agrees to implement any and all changes in providing services hereunder as a result of a policy change implemented by the City. The Bidder agrees to act in an expeditious and fiscally sound manner in providing the City with input regarding the time and cost to implement said changes and in executing the activities required to implement said changes

#### **1.58 AUTHORITY OF THE CITY'S ENGINEER**

The Bidder hereby acknowledges that the City's ENGINEER will determine in the first instance all questions of any nature whatsoever arising out of, under, or in connection with, or in any way related to or on account of, this Agreement including without limitations: questions as to the value, acceptability and fitness of the services; questions as to either party's fulfillment of its obligations under the Contract; negligence, fraud or misrepresentation before or subsequent to acceptance of the Bid; questions as to the interpretation of the Scope of Services; and claims for damages, compensation and losses.

The Bidder shall be bound by all determinations or orders and shall promptly obey and follow every order of the ENGINEER, including the withdrawal or modification of any previous order and regardless of whether the Bidder agrees with the ENGINEER's determination or order. Where orders are given orally, they will be issued in writing by the ENGINEER as soon thereafter as is practicable.

The Bidder must, in the final instance, seek to resolve every difference concerning the Agreement with the ENGINEER. In the event that the ENGINEER and the Bidder are unable to resolve their difference, the Bidder may initiate a dispute in accordance with the procedures set forth in the section below. Exhaustion of these procedures shall be a condition precedent to any lawsuit permitted hereunder.

In the event of such dispute, the parties to this Agreement authorize the City Manager or designee, who may not be the ENGINEER or anyone associated with this Project, acting personally, to decide all questions arising out of, under, or in connection with, or in any way related to or on account of the Agreement (including but not limited to claims in the nature of breach of contract, fraud or misrepresentation arising either before or subsequent to execution hereof) and the decision of each with respect to matters within the City Manager's purview as set forth above shall be conclusive, final and binding on the parties. Any such dispute shall be brought, if at all, before the City Manager within 10 days of the occurrence, event or act out of which the dispute arises.

The City Manager may base this decision on such assistance as may be desirable, including advice of experts, but in any event shall base the decision on an independent and objective determination of whether the Bidder's performance or any deliverable meets the requirements of this Agreement and any specifications with respect thereto set forth herein. The effect of any decision shall not be impaired or waived by any negotiations or settlements or offers made in connection with the dispute, whether or not the City Manager participated therein, or by any prior decision of others, which prior decision shall be deemed subject to review, or by any termination or cancellation of the Agreement. All such disputes shall be submitted in writing by the Bidder to the City Manager for a decision, together with all pertinent information in regard to such questions, in order that a fair and impartial decision may be made. The parties agree that whenever the City Manager is entitled to exercise discretion or judgment or to make a determination or form an opinion pursuant to the provisions of this Article, such action shall be deemed fair and impartial when exercised or taken. The City Manager shall render a decision in writing and deliver a copy of the same to the Bidder. Except as such remedies may be limited or waived elsewhere in the Agreement, the Bidder reserves the right to pursue any remedies available under law after exhausting the provisions of this Article.

### **1.59 MUTUAL OBLIGATIONS**

This Agreement, including attachments and appendices to the Agreement, shall constitute the entire Agreement between the parties with respect hereto and supersedes all previous communications and representations or agreements, whether written or oral, with respect to the subject matter hereof unless acknowledged in writing by the duly authorized representatives of both parties.

Nothing in this Agreement shall be construed for the benefit, intended or otherwise, of any third party that is not a parent or subsidiary of a party or otherwise related (by virtue of ownership control or statutory control) to a party.

In those situations where this Agreement imposes an indemnity or defense obligation on the Bidder, the City may, at its expense, elect to participate in the defense if the City should so choose. Furthermore, the City may at its own expense defend or settle any such claims if the Bidder fails to diligently defend such claims, and thereafter seek indemnity for costs and attorney's fees from the Bidder.

### **1.60 SUBCONTRACTUAL RELATIONS**

If the Bidder will cause any part of this Agreement to be performed by a sub bidder, the provisions of this Contract will apply to such sub bidder and its officers, agents and employees in all respects as if it and they were employees of the Proposer; and the Proposer will not be in any manner thereby discharged from its obligations and liabilities hereunder, but will be liable hereunder for all acts and negligence of the sub bidder, its officers, agents, and employees, as if they were employees of the Proposer. The services performed by the sub bidder will be subject to the provisions hereof as if performed directly by the Bidder.

The Bidder, before making any subcontract for any portion of the services, will state in writing to the City the name of the proposed sub bidder, the portion of the services which the sub bidder is to do, the place of business of such sub bidder, and such other information as the City may require. The City will have the right to require the Bidder not to award any subcontract to a person, firm or corporation disapproved by the City.

Before entering into any subcontract hereunder, the Bidder will inform the sub bidder fully and completely of all provisions and requirements of this Agreement relating either directly or indirectly to the services to be performed. Such services performed by such sub bidder will strictly comply with the requirements of this Contract.

In order to qualify as a sub bidder satisfactory to the City, in addition to the other requirements herein provided, the sub bidder must be prepared to prove to the satisfaction of the City that it has the necessary facilities, skill and experience, and ample financial resources to perform the services in a satisfactory manner. To be considered skilled and experienced, the sub bidder must show to the satisfaction of the City that it has satisfactorily performed services of the same general type which are required to be performed under this Agreement.

The City shall have the right to withdraw its consent to a subcontract if it appears to the City that the subcontract will delay, prevent, or otherwise impair the performance of the Bidder's obligations under this Agreement. All sub bidder are required to protect the confidentiality of the City and City's proprietary and confidential information. The Bidder shall furnish to the City copies of all subcontracts between the Bidder and sub bidder and suppliers hereunder. Within each such subcontract, there shall be a clause for the benefit of the City permitting the City to request completion of performance by the sub bidder of its obligations under the subcontract, in the event the City finds the Bidder in breach of its obligations, and the option to pay the sub bidder directly for the performance by such sub bidder. The foregoing shall neither convey nor imply any obligation or liability on the part of the City to any sub bidder hereunder as more fully described herein.

### **1.61 PROMPT PAYMENT: LATE PAYMENTS BY BIDDER TO SUB BIDDER AND MATERIAL SUPPLIERS; PENALTY:**

When a Bidder receives from the City of Hollywood any payment for contractual services, commodities, materials, supplies, or construction contracts, the proposer shall pay such moneys received to each sub bidder and material supplier in proportion to the percentage of work completed by each sub bidder and material supplier at the time of receipt. If the Bidder receives less than full payment, then the proposer shall be required to disburse only the funds received on a pro rata basis to the sub bidder and materials Suppliers, each receiving a prorated portion based on the amount due on the payment. If the proposer without reasonable cause fails to make payments required by this section to sub bidder and material suppliers within fifteen (15) working days after the receipt by the Bidder of full or partial payment, the proposer shall pay to the sub bidder and material suppliers a penalty in the amount of one percent (1%) of the amount due, per month, from the expiration of the period allowed herein for payment. Such penalty shall be in addition to actual payments owed. Retainage is also subject to the prompt payment requirement and must be returned to the sub bidder or material

supplier whose work has been completed, even if the prime contract has not been completed. The Bidder shall include the above obligation in each subcontract it signs with a sub bidder or material supplier.

#### **1.62 TERMINATION FOR CONVENIENCE AND SUSPENSION OF WORK**

The City may terminate this Agreement if an individual or corporation or other entity attempts to meet its contractual obligation with the City through fraud, misrepresentation or material misstatement.

The City may, as a further sanction, terminate or cancel any other contract(s) that such individual or corporation or other entity has with the City. Such individual, corporation or other entity shall be responsible for all direct and indirect costs associated with such termination or cancellation, including attorney's fees.

The foregoing notwithstanding, any individual, corporation or other entity which attempts to meet its contractual obligations with the City through fraud, misrepresentation or material misstatement may be debarred from City contracting in accordance with the City debarment procedures. The Bidder may be subject to debarment for failure to perform and any other reasons related to the Bidder's breach or failure of satisfactory performance.

In addition to cancellation or termination as otherwise provided in this Agreement, the City may at any time, in its sole discretion, with or without cause, terminate this Agreement by written notice to the Bidder and in such event:

The Bidder shall, upon receipt of such notice, unless otherwise directed by the City:

1. Stop work on the date specified in the notice ("the Effective Termination Date");
2. Take such action as may be necessary for the protection and preservation of the City's materials and property;
3. Cancel orders;
4. Assign to the City and deliver to any location designated by the City any non-cancelable orders for deliverables that are not capable of use except in the performance of this Agreement and which have been specifically developed for the sole purpose of this Agreement and not incorporated in the services;
5. Take no action which will increase the amounts payable by the City under this Agreement.

In the event that the City exercises its right to terminate this Agreement pursuant to this Article, the Bidder will be compensated as stated in the payment articles herein, for the:

1. Portion of the services completed in accordance with the Agreement up to the Effective Termination Date; and
2. Non-cancelable deliverables that are not capable of use except in the performance of this Agreement and which have been specifically developed for the sole purpose of this Agreement but not incorporated in the services.

All compensation pursuant to this Article is subject to audit.

#### **1.63 EVENT OF DEFAULT**

An Event of Default shall mean a breach of this Agreement by the Bidder. Without limiting the generality of the foregoing and in addition to those instances referred to herein as a breach, an Event of Default, shall include the following:

1. The Bidder has not delivered deliverables on a timely basis;
2. The Bidder has refused or failed, except in any case for which an extension of time is provided, to supply enough properly skilled staff personnel;
3. The Bidder has failed to make prompt payment to sub bidder or suppliers for any services;

4. The Bidder has become insolvent (other than as interdicted by the bankruptcy laws), or has assigned the proceeds received for the benefit of the Bidder 's creditors, or the Bidder has taken advantage of any insolvency statute or debtor/creditor law or if the Bidder 's affairs have been put in the hands of a receiver;
5. The Bidder has failed to obtain the approval of the City where required by this Agreement;
6. The Bidder has failed to provide "adequate assurances" as required under subsection "B" below; and
7. The Bidder has failed in the representation of any warranties stated herein.

When, in the opinion of the City, reasonable grounds for uncertainty exist with respect to the Proposer's ability to perform the services or any portion thereof, the City may request that the Proposer, within the time frame set forth in the City's request, provide adequate assurances to the City, in writing, of the Proposer's ability to perform in accordance with terms of this Agreement. Until the City receives such assurances the City may request an adjustment to the compensation received by the Proposer for portions of the services which the Proposer has not performed. In the event that the Proposer fails to provide to the City the requested assurances within the prescribed time frame, the City may:

1. Treat such failure as a repudiation of this Agreement;
2. Resort to any remedy for breach provided herein or at law, including but not limited to, taking over the performance of the services or any part thereof either by itself or through others.

In the event the City shall terminate this Agreement for default, the City or its designated representatives may immediately take possession of all applicable equipment, materials, products, documentation, reports and data.

#### **1.64 REMEDIES IN THE EVENT OF DEFAULT**

If an Event of Default occurs, the Proposer shall be liable for all damages resulting from the default, including but not limited to:

- A. Lost revenues;
- B. The difference between the cost associated with procuring services hereunder and the amount actually expended by the City for procurement of services, including procurement and administrative costs; and,
- C. Such other damages that the City may suffer.

The Proposer shall also remain liable for any liabilities and claims related to the Proposer's default. The City may also bring any suit or proceeding for specific performance or for an injunction.

#### **1.65 BANKRUPTCY**

The City reserves the right to terminate this contract if, during the term of any contract the Proposer has with the City, the Proposer becomes involved as a debtor in a bankruptcy proceeding, or becomes involved in a reorganization, dissolution, or liquidation proceeding, or if a trustee or receiver is appointed over all or a substantial portion of the property of the Proposer under federal bankruptcy law or any state insolvency law.

#### **1.66 CANCELLATION FOR UNAPPROPRIATED FUNDS**

The obligation of the City for payment to a Proposer is limited to the availability of funds appropriated in a current fiscal period, and continuation of the contract into a subsequent fiscal period is subject to appropriation of funds, **unless otherwise authorized by law.**

#### **1.67 VERBAL INSTRUCTIONS PROCEDURE**

No negotiations, decisions, or actions shall be initiated or executed by the Proposer as a result of any discussions with any City employee. Only those communications which are in writing from an authorized City representative may be considered. Only written communications from Proposers, which are signed by a person designated as authorized to bind the Proposer, will be recognized by the City as duly authorized expressions on behalf of the Proposer.

#### **1.68 E-VERIFY**

Proposer acknowledges that the City may be utilizing the Proposer's services for a project that is funded in whole or in part by State funds pursuant to a contract between the City and a State agency. The Proposer shall be responsible for complying with the E-Verify requirements in the contract and using the U.S. Department of Homeland Security's E-Verify system to verify the employment of all new employees hired by the Proposer during the Agreement term. The Proposer is also responsible for e-verifying its bidders, if any, pursuant to any agreement between the City and a State Agency, and reporting to the City any required information. The Proposer acknowledges that the terms of this paragraph are material terms, the breach of any of which shall constitute a default under this Agreement.

#### **1.69 BUDGETARY CONSTRAINTS**

In the event the City is required to reduce contract costs due to budgetary constraints, all services specified in this document may be subject to a permanent or temporary reduction in budget. In such an event, the total cost for the affected service shall be reduced as required. The Proposer shall also be provided with a minimum 30-day notice prior to any such reduction in budget.

#### **1.70 COST ADJUSTMENTS (As Applicable)**

The cost for all items as quoted herein shall remain firm for the first term of the contract. Costs for subsequent years and any extension term years shall be subject to an adjustment only if increases occur in the industry. However, unless very unusual and significant changes have occurred in the industry, such increases shall not exceed 3% per year or, whichever is less, the latest yearly percentage increase in the All Urban Consumers Price Index (CPU-U) (National) as published by the Bureau of Labor Statistics, U.S. Dept. of Labor. The yearly increase or decrease in the CPI shall be that latest index published and available ninety (90) days prior to the end of the contract year than in effect compared to the index for the same month one year prior. Any requested cost increase shall be fully documented and submitted to the City at least ninety (90) days prior to the contract anniversary date. Any approved cost adjustments shall become effective upon the anniversary date of the contract. In the event the CPI or industry costs decline, the City shall have the right to receive from the Proposer a reduction in costs that reflects such cost changes in the industry. The City may, after examination, refuse to accept the adjusted costs if they are not properly documented, increases are considered to be excessive, or decreases are considered to be insufficient. In the event the City does not wish to accept the adjusted costs and the matter cannot be resolved to the satisfaction of the City, the contract can be cancelled by the City upon giving thirty (30) days written notice to the Proposer.

#### **1.71 OSHA STANDARDS**

Proposer acknowledges and agrees that as Contractor for the City of Hollywood, Florida, within the limits of the City of Hollywood, Florida, will have the sole responsibility for compliance with all requirements of the Federal Occupational Safety and Health Act of 1970, and all State and local safety and health regulations, and agrees to defend, indemnify and hold harmless the City of Hollywood, Florida, its officials, employees, service providers, and its agents against any and all legal liability or loss the City of Hollywood, Florida may incur due to the Contractor's failure to comply with such act.

*END OF SECTION*



City of Hollywood  
Procurement Services  
Steve Stewart, Chief Procurement Officer  
2600 Hollywood Boulevard, Hollywood, FL 33020

---

## PROPOSAL DOCUMENT REPORT

IFB No. REQ-038-23-JJ

Clarifier No. 3 Repair

RESPONSE DEADLINE: March 2, 2023 at 3:00 pm

Report Generated: Monday, March 6, 2023

## Razorback LLC Proposal

### CONTACT INFORMATION

**Company:**

Razorback LLC

**Email:**

anthony@razorbackllc.com

**Contact:**

Anthony Houllis

**Address:**

177 Anclote Road  
Tarpon Springs, FL 34689

**Phone:**

N/A

**Website:**

<https://www.razorbackllc.com/>

**Submission Date:**

Mar 2, 2023 2:46 PM



## ADDENDA CONFIRMATION

Addendum #1

*Confirmed Mar 2, 2023 2:11 PM by Anthony Houllis*

Addendum #2

*Confirmed Mar 2, 2023 2:11 PM by Anthony Houllis*

Addendum #3

*Confirmed Mar 2, 2023 2:11 PM by Anthony Houllis*

Addendum #4

*Confirmed Mar 2, 2023 2:11 PM by Anthony Houllis*

## QUESTIONNAIRE

### 1. SUBMITTAL CHECKLIST CONFIRMATION\*

The items below are required components of your solicitation response in order for your bid/proposal/submittal to be considered responsive and responsible. Please confirm this submittal includes the following items in this checklist

- A. Forms and Certifications (Completed)
  - 1. This Submittal Checklist Confirmation
  - 2. Information Required from Bidders
  - 3. Bid Form (see [#PRICING \(BID FORM\)](#))
  - 4. Vendor Reference Form\*
  - 5. Hold Harmless and Indemnity Clause
  - 6. Non-Collusion Statement

7. Sworn Statement...Public Entity Crimes
8. Certifications Regarding Debarment
9. Drug-Free Workplace Program
10. Solicitation, Giving, and Acceptance
11. W-9 (Request for Taxpayer Identification)
12. Trench Safety Form
13. Bid Guaranty Form
14. List of Subcontractors
15. Certificate(s) of insurance that meet the requirements of the [#SPECIAL TERM AND CONDITIONS](#) section.
16. Proof of State of Florida Sunbiz Registration
17. Acknowledgement and Signature Questionnaire
18. Proposal Form

This checklist is only a guide, please read the entire solicitation to ensure that your submission includes all required information and documentation.

Confirmed

## **2. INFORMATION REQUIRED FROM BIDDERS\***

### GENERAL INFORMATION

The Bidder shall furnish the following information. Failure to comply with this requirement may cause its rejection. Additional sheets shall be attached as required.

- A. Contractor's License (attach copy):
  1. Primary Classification:

2. Broward County License Number (attach copy):
- B. Number of years as a Contractor in construction work of the type involved in this Contract:
- C. List the names and titles of all officers of Contractor's firm:
- D. Name of person who inspected site or proposed work for your firm:
  1. Name:
  2. Date of Inspection:
- E. What is the last project of this nature you have completed?
- F. Have you ever failed to complete work awarded to you; if so, where and why?
- G. Name three individuals or corporations for which you have performed work and to which you refer:
- H. List the following information concerning all contracts on hand as of the date of submission of this proposal (in case of co-venture, list the information for all coventures).
  1. Name of Project
  2. City
  3. Total Contract Value
  4. Contracted Date of Completion
  5. % Completion to Date
- I. What equipment do you own that is available for the work?
- J. What equipment will you purchase for the proposed work?
- K. List at least three (3) similar projects completed within the last seven (7) years by the bidder and the proposed project manager. For purposes of this requirement, 'similar' projects shall be considered to include projects of similar size and scope as outlined in the Scope of Work/Services section. Include owner, project value, completion date, reference contact

information, and brief project description. The determination of whether a project is sufficiently similar shall be at the sole discretion of the City and the Engineer.

- L. Name the Project Manager proposed for this project. Attach a copy of the project manager's resume.
- M. Information and/or documentation that addresses and/or meets the requirements outlined in the Scope of Work/Services section, including any procedural or technical enhancements/innovations which do not materially deviate from the objectives or required content of the Scope of Work/Services.

NOTE: If requested by CITY, the Bidder shall furnish a notarized financial statement, references and other information, sufficiently comprehensive to permit an appraisal of its current financial condition.

General\_Information.pdf

### 3. PRICING (BID FORM)\*

I understand that I shall insert my pricing electronically in the [#PRICING \(BID FORM\)](#) section.

Confirmed

### 4. VENDOR REFERENCE FORM\*

Please download the below documents, complete, and upload.

- [Vendor Reference Form.pdf](#)

Vendor\_Reference\_Forms.pdf

### 5. HOLD HARMLESS AND INDEMNITY CLAUSE\*

I, an authorized representative, the contractor, shall indemnify, defend and hold harmless the City of Hollywood, its elected and appointed officials, employees and agents for any and all suits, actions, legal or administrative proceedings, claims, damage, liabilities, interest, attorney's fees, costs of any kind whether arising prior to the start of activities or following the completion or acceptance and in any manner directly or indirectly caused, occasioned or contributed to in whole or in part by reason of any act, error or omission, fault or negligence whether active or passive by the contractor, or anyone acting under its direction, control, or on its behalf in connection with or incident to its performance of the contract.

Confirmed

#### 6. NON-COLLUSION STATEMENT\*

I, being first duly sworn, depose that:

- A. He/she is an authorized representative of the Company, the Proposer that has submitted the attached Proposal.
- B. He/she has been fully informed regarding the preparation and contents of the attached Proposal and of all pertinent circumstances regarding such Proposal;
- C. Such Proposal is genuine and is not a collusion or sham Proposal;
- D. Neither the said Proposer nor any of its officers, partners, owners, agents, representatives, employees or parties in interest, including this affiant has in any way colluded, conspired, connived or agreed, directly or indirectly with any other Proposer, firm or person to submit a collusive or sham Proposal in connection with the contractor for which the attached Proposal has been submitted or to refrain from bidding in connection with such contract, or has in any manner, directly or indirectly, sought by agreement or collusion or communication or conference with any other Proposer, firm or person to fix the price or prices, profit or cost element of the Proposal price or the Proposal price of any other Proposer, or to secure an advantage against the City of Hollywood or any person interested in the proposed Contract; and
- E. The price or prices quoted in the attached Proposal are fair and proper and are not tainted by any collusion, conspiracy, connivance or unlawful agreement on the part of the Proposer or any of its agents, representatives, owners, employees, or parties in interest, including this affiant.

Confirmed

#### 7. SWORN STATEMENT PURSUANT TO SECTION 287.133 (3) (a) FLORIDA STATUTES ON PUBLIC ENTITY CRIMES\*

Please download the below documents, complete, and upload.

- [Sworn Statement Public Enti...](#)

Sworn\_Statement\_Public\_Entity\_Crimes\_Form.pdf

## **8. CERTIFICATIONS REGARDING DEBARMENT, SUSPENSION AND OTHER RESPONSIBILITY MATTERS\***

The applicant certifies that it and its principals:

- A. Are not presently debarred, suspended, proposed for debarment, declared ineligible, sentenced to a denial of Federal benefits by a State or Federal court, or voluntarily excluded from covered transactions by any Federal department or agency;
- B. Have not within a three-year period preceding this application been convicted of or had a civil judgment rendered against them for commission of fraud or a criminal offense in connection with obtaining, attempting to obtain, or performing a public (Federal, State, or local) transaction or contract under a public transaction, violation of Federal or State antitrust statutes or commission of embezzlement, theft, forgery, bribery, falsification or destruction of records, making false statements, or receiving stolen property;
- C. Are not presently indicted for or otherwise criminally or civilly charged by a governmental entity (Federal, State, or local) with commission of any of the offenses enumerated in paragraph (b) of this certification; and
- D. Have not within a three-year period preceding this application had one or more public transactions (Federal, State, or local) terminated for cause or default.

Confirmed

## **9. DRUG-FREE WORKPLACE PROGRAM\***

- A. IDENTICAL TIE PROPOSALS - Preference shall be given to businesses with drug-free workplace programs. Whenever two or more bids which are equal with respect to price, quality, and service are received by the State or by any political subdivision for the procurement of commodities or contractual services, a bid received from a business that certifies that it has implemented a drug-free workplace program shall be given preference in the award process. Established procedures for processing tie proposals will be followed if none of the tied vendors have a drug-free workplace program. In order to have a drug-free workplace program, a business shall:
  - 1. Publish a statement notifying employees that the unlawful manufacture, distribution, dispensing, possession, or use of a controlled substance is prohibited in the workplace and specifying the actions that will be taken against employees for violations of such prohibition.

2. Inform employees about the dangers of drug abuse in the workplace, the business's policy of maintaining a drug-free workplace, any available drug counseling, rehabilitation, and employee assistance programs, and the penalties that may be imposed upon employees for drug abuse violations.
3. Give each employee engaged in providing the commodities or contractual services that are under bid a copy of the statement specified in subsection (1).
4. In the statement specified in subsection (1), notify the employee that, as a condition of working on the commodities or contractual services that are under bid, the employee will abide by the terms of the statement and will notify the employer of any conviction of, or plea of guilty or nolo contendere to, any violation of chapter 893 or of any controlled substance law of the United States or any state, for a violation occurring in the workplace no later than five (5) days after such conviction.
5. Impose a sanction on, or require the satisfactory participation in a drug abuse assistance or rehabilitation program (if such is available in the employee's community) by, any employee who is so convicted.
6. Make a good faith effort to continue to maintain a drug-free workplace through implementation of these requirements.

As the person authorized to sign the statement, I certify that this firm complies fully with the above requirements.

Confirmed

#### **10. SOLICITATION, GIVING, AND ACCEPTANCE OF GIFTS POLICY \***

Florida Statute 112.313 prohibits the solicitation or acceptance of Gifts. "No Public officer, employee of an agency, local government attorney, or candidate for nomination or election shall solicit or accept anything of value to the recipient, including a gift, loan, reward, promise of future employment, favor, or service, based upon any understanding that the vote, official action, or judgment of the public officer, employee, local government attorney, or candidate would be influenced thereby." The term "public officer" includes "any person elected or appointed to hold office in any agency, including any person serving on an advisory body."

The City of Hollywood/Hollywood CRA policy prohibits all public officers, elected or appointed, all employees, and their families from accepting any gifts of any value, either directly or indirectly, from any contractor, vendor, consultant, or business with whom the City/CRA does business.

The State of Florida definition of "gifts" includes the following:

- Real property or its use,
- Tangible or intangible personal property, or its use,
- A preferential rate or terms on a debt, loan, goods, or services,
- Forgiveness of indebtedness,
- Transportation, lodging, or parking,
- Food or beverage,
- Membership dues,
- Entrance fees, admission fees, or tickets to events, performances, or facilities,
- Plants, flowers or floral arrangements
- Services provided by persons pursuant to a professional license or certificate.
- Other personal services for which a fee is normally charged by the person providing the services.
- Any other similar service or thing having an attributable value not already provided for in this section.

Any contractor, vendor, consultant, or business found to have given a gift to a public officer or employee, or his/her family, will be subject to dismissal or revocation of contract.

As the person authorized to sign the statement, I certify that this firm will comply fully with this policy.

Confirmed

#### **11. W9 FORM\***

Please download the below documents, complete, and upload.

- [Form 11 - W-9.pdf](#)

W-9.pdf



## 12. TRENCH SAFETY\*

Please download the below documents, complete, and upload.

- [Form 12 - Trench Safety For...](#)

Trench\_Safety\_Form.pdf

## 13. BID GUARANTY FORM\*

Please download the below documents, complete, and upload.

- [Form 13 - Bid Guaranty Form...](#)

Bid\_Bond\_Form.pdf

## 14. LIST OF SUBCONTRACTORS\*

Please download the below documents, complete, and upload.

- [Form 14 - List of Subcontra...](#)

List\_of\_Subcontractors\_Form.pdf

## 15. Certificate of Insurance\*

See requirements in the [#SPECIAL TERM AND CONDITIONS](#) section.

Certificate\_of\_Insurance.pdf

## 16. PROOF OF SUNBIZ REGISTRATION\*

Enter company FEIN to be verified in Sunbiz

26-3447303

[Click to Verify](#) *Value will be copied to clipboard*

## 17. ACKNOWLEDGMENT AND SIGNATURE PAGE

IF CORPORATION - DATE INCORPORATED/ORGANIZED:\*

09/18/2008

STATE INCORPORATED/ORGANIZED:\*

Florida

REMITTANCE ADDRESS\*

177 Anclote Rd, Tarpon Springs, FL 34689

BIDDER/PROPOSER'S AUTHORIZED REPRESENTATIVE'S TYPED FULL NAME\*

Anthony Houllis

IT IS HEREBY CERTIFIED AND AFFIRMED THAT THE BIDDER/PROPOSER CERTIFIES ACCEPTANCE OF THE TERMS, CONDITIONS, SPECIFICATIONS, ATTACHMENTS AND ANY ADDENDA. THE BIDDER/PROPOSER SHALL ACCEPT ANY AWARDS MADE AS A RESULT OF THIS SOLICITATION. BIDDER/PROPOSER FURTHER AGREES THAT PRICES QUOTED WILL REMAIN FIXED FOR THE PERIOD OF TIME STATED IN THE SOLICITATION.\*

Confirmed

THE EXECUTION OF THIS FORM CONSTITUTES THE UNEQUIVOCAL OFFER OF BIDDER/PROPOSER TO BE BOUND BY THE TERMS OF ITS PROPOSAL. FAILURE TO SIGN THIS SOLICITATION WHERE INDICATED BY AN AUTHORIZED REPRESENTATIVE SHALL RENDER THE BID/PROPOSAL NON-RESPONSIVE. THE CITY MAY, HOWEVER, IN ITS SOLE DISCRETION, ACCEPT ANY BID/PROPOSAL THAT INCLUDES AN EXECUTED DOCUMENT WHICH UNEQUIVOCALLY BINDS THE BIDDER/PROPOSER TO THE TERMS OF ITS OFFER.\*

Confirmed

PROPOSAL FORM\*

Please download the below documents, complete, and upload.

- [Proposal Form.docx](#)

Proposal\_Form.pdf Proposal\_Package.pdf

## PRICE TABLES

### BID ITEMS

Line Item	Description	Quantity	Unit of Measure	Unit Cost	Total
1	Mobilization (shall not exceed 3% of the sum of Bid Items No. 2 and No. 3).	1	Lump Sum	\$17,000.00	\$17,000.00
2	Clarifier No. 3 Repair: All work required for the repair of a failed 16-inch diameter 90-degree elbow joint and pipe segment on the return sludge line (ductile iron pipe) located below grade within the 48-inch diameter clarifier feed line at Clarifier No. 3, as required in the Contract Documents.	1	Lump Sum	\$390,000.00	\$390,000.00
3	Clarifier No. 3 Reinstallation of Mechanism: All work required for the reinstallation of Clarifier No. 3 mechanism if removed under Bid Item No. 2, including reassembly/installation of existing equipment post-repair, and all work necessary to return clarifier to service.	1	Lump Sum	\$178,000.00	\$178,000.00
4	Permit Fee Allowance	1	Allowance	\$50,000.00	\$50,000.00
5	Undefined Conditions Allowance	1	Allowance	\$285,000.00	\$285,000.00
6	Consideration for Indemnification	1	\$10.00	\$10.00	\$10.00
7	Demobilization (shall not exceed 3% of the sum of Bid Items No. 2 and No. 3).	1	Lump Sum	\$2,000.00	\$2,000.00
8	Field Crew (Superintendent)	40	HR	\$75.00	\$3,000.00

Line Item	Description	Quantity	Unit of Measure	Unit Cost	Total
9	Field Crew (Operator)	40	HR	\$60.00	\$2,400.00
10	Field Crew (Laborer x 2)	40	HR	\$45.00	\$1,800.00
11	Equipment, Excavator, 5 CY	40	HR	\$75.00	\$3,000.00
12	Equipment, Flat Bed Truck, 12'	40	HR	\$50.00	\$2,000.00
13	Equipment, Loader	40	HR	\$50.00	\$2,000.00
<b>TOTAL</b>					<b>\$936,210.00</b>

**ALTERNATE BID ITEMS**

Line Item	Description	Quantity	Unit of Measure	Unit Cost	Total
A-1	Furnish and Install Clarifier No. 3 Equipment (Complete Mechanism Replacement, Carbon Steel): All work for complete replacement of the mechanism at Clarifier No. 3, in the event it is deemed necessary. The material of the replacement mechanism shall be carbon steel components with required surface preparation and coating system per the Contract documents. Work includes but is not limited to furnishing, delivering, installing and testing Clarifier No. 3 drive and associated appurtenances.	1	Lump Sum	\$2,580,000.00	\$2,580,000.00
A-2	Furnish and Install Clarifier No. 3 Equipment (Complete Mechanism Replacement, 316 Stainless Steel): All work for complete replacement of the mechanism at Clarifier No. 3, in the event it is deemed necessary. The material of the replacement mechanism shall be 316 stainless steel components per the Contract documents. Work includes but is not limited to furnishing, delivering, installing and testing Clarifier No. 3 drive and associated appurtenances.	1	Lump Sum	\$3,616,000.00	\$3,616,000.00

Line Item	Description	Quantity	Unit of Measure	Unit Cost	Total
A-3	Furnish and Install Clarifier No. 3 Weirs and Scum Baffles: All work for replacement of the fiberglass v-notched weirs and scum baffles at Clarifier No. 3, in the event it is deemed necessary. Item shall include payment for all labor, equipment, and materials for all work necessary and required for the replacement of equipment, as detailed in the Contract Documents, for a complete and operable system.	1	Lump Sum	\$647,619.00	\$647,619.00
A-4	Furnish and Install Clarifier No. 3 Density Current Baffles: All work for replacement of the density current baffles at Clarifier No. 3, in the event it is deemed necessary. Item shall include payment for all labor, equipment, and materials for all work necessary and required for the replacement of equipment, as detailed in the Contract Documents, for a complete and operable system.	1	Lump Sum	\$444,602.00	\$444,602.00
<b>TOTAL</b>					<b>\$7,288,221.00</b>

FORM 15

INFORMATION REQUIRED FROM BIDDERS

GENERAL INFORMATION

The Bidder shall furnish the following information. Failure to comply with this requirement may cause its rejection. Additional sheets shall be attached as required.

1. Contractor's Name/Address: Razorback LLC  
177 Anclote Road, Tarpon Springs, FL 34689  
\_\_\_\_\_
  
2. Contractor's Telephone Number: (727) 938-9500  
and e-mail address: ANTHONY@RAZORBACKLLC.COM
  
3. Contractor's License (attach copy): CGC1526612  
Primary Classification: Certified General Contractor  
Broward County License Number (attach copy): \_\_\_\_\_
  
4. Number of years as a Contractor in construction work of the type involved in this Contract: 14+ years  
\_\_\_\_\_
  
5. List the names and titles of all officers of Contractor's firm:  
Anthony Houllis, MGRM  
\_\_\_\_\_  
\_\_\_\_\_  
\_\_\_\_\_
  
6. Name of person who inspected site or proposed work for your firm:  
Name: Trivon McDade  
Date of Inspection: 02/01/2023
  
7. What is the last project of this nature you have completed?  
Rehabilitate Everglades Flamingo Wastewater Treatment Plant  
\_\_\_\_\_

8. Have you ever failed to complete work awarded to you; if so, where and why?

No

9. Name three individuals or corporations for which you have performed work and to which you refer:

Royal Bridge Inc.

US Water Services Corp.

Jacksonville Aviation Authority

10. List the following information concerning all contracts on hand as of the date of submission of this proposal (in case of co-venture, list the information for all coventures).

Name of Project	City	Total Contract Value	Contracted Date of Completion	% Completion to Date
Master Water Treatment Plant	City of West Palm Beach	\$501,445.16	05/27/2024	Term - 80%
Utilities Painting Maintenance Continuing Services	Town of Jupiter	\$1,459,308	11/02/2023	Term - 90%
Re-painting of Aerial Crossings	Charlotte County	\$361,167.70	09/30/2023	Term - 80%
As Needed Utilities General Maintenance Services	Pasco County	\$97,045	11/18/2025	Term - 10%

(Continue list on inset sheet, if necessary) \*\*See attached

11. What equipment do you own that is available for the work?

\*\*\*See attached equipment list

12. What equipment will you purchase for the proposed work?

None Anticipated

13. List at least three (3) similar projects completed within the last five (5) years by the bidder and the proposed project manager. For purposes of this requirement, 'similar' projects shall be considered to include wastewater treatment equipment

and mechanical piping systems. Include owner, project value, completion date, reference contact information and brief project description. The determination of whether a project is sufficiently similar shall be at the sole discretion of the City and the Engineer.

See attached similar projects

---

---

---

---

---

(Add sheets as requested.)

14. Name the Project Manager proposed for this project. Attach a copy of the project manager's resume.

Daniel Dion

---

NOTE: If requested by CITY, the Bidder shall furnish a notarized financial statement, references and other information, sufficiently comprehensive to permit an appraisal of its current financial condition.



**Current Contracts**

Owner	Name of Project	Total Contract Value	Completion Date	Term	% of Completion to Date
CITY OF W PALM BEACH	MASTER WATER TREATMENT PLANT	\$501,445.16	5/27/2024	TERM	80%
TOWN OF JUPITER	UTILITIES PAINTING MAINTENANCE- CONT. SERVICES TERM	\$1,459,308.00	11/2/2023	TERM	90%
CITY OF ST. PETE	Painting, Water-Proofing and Associated Services TERM	\$328,000.00	8/31/2023	TERM	80%
CHARLOTTE COUNTY	Re-Painting of Aerial Crossings	\$361,167.70	9/30/2023	TERM	80%
PALM BEACH COUNTY	PAINTING, WATERPROOFING & ASSOC. SERVICES	\$193,627.88	4/9/2023	TERM	95%
HERNANDO COUNTY	Hernando Beach Water Tower Maintenance TERM (9-28-21 trough 9-27-24)	\$82,060.00	9/27/2024	TERM	95%
PEACE RIVER MANASOTA REGIONAL WATER SUPPLY AUTHORITY	As Needed Painting & Coating Services 5-Year TERM (12/1/2021 through 12/1/2026)	\$328,162.56	12/1/2026	TERM	40%
SYNERGY NDS	City of Dunedin Walls & Ceiling Painting	\$93,700.00			90%
CITY OF MIRAMAR	Pool of Qualified GCs for Small Scale Commercial Rehab Projects	TBD	5/13/2024	TERM	TBD
CITY OF TREASURE ISLAND	Small Project GC Construction Services	TBD	5/3/2025	TERM	TBD
CLAY COUNTY UTILITY AUTHORITY	Ground Storage Tank Maintenance & Rehabilitation Services	TBD	5/26/2025	TERM	TBD
CITY OF CLEARWATER	WTP 3 East Dome and Aeator & Misc Improvements	\$1,791,334.60			5%
PASCO COUNTY (TERM)	As Needed Utilities General Maintenance Services(3-year Term)	\$97,045.00	11/18/2025	TERM	10%
BAY TO BAY PROPERTIES	Bubble Down Car Wash - New River	TBD			TBD
DESOTO COUNTY	Utilities Potable Water Tanks Repair & Maintenance	\$353,675.00			99%
CITY OF HOLLY HILL	WTP Chlorine Canopy Replacement	\$298,000.00	2/5/2023		100%
SYNERGY NDS	Water Treatment Plant Pipe & Motor	\$5,200.00			80%
FDEP	Gasparilla Island Hurricane Ian	\$277,000.00			70%
NEW SMYRNA BEACH UTILITIES	GWTP Lime Silo Structural Repairs	\$89,000.00	12/22/2022		100%
CITY OF QUINCY	WTP Ground Storage Tank Repair	\$30,000.00	1/18/2023		100%
LEE COUNTY	Pressure Washing Services	\$0.00	TBD	TERM	TBD
ROWLAND INC	City of Clearwater Stevenson Creek Bridge Piping Part 2	\$11,450.00	1/23/2023		100%
CITY OF PALM COAST	Elevated Tank Inspections	\$4,424.00	12/28/2023	TERM	100%
SUPERIOR SCHOOLS	Steeple Rehab	\$23,000.00	1/9/2023		100%
LEE COUNTY	Painting Services - Annual	TBD		TERM	TBD
CITY OF NORTH MIAMI BEACH	Norwood Sulfuric Acid Containment	\$128,350.00			0%

Ron DeSantis, Governor

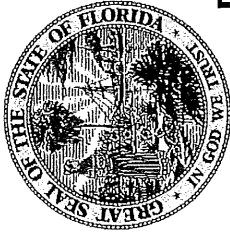

Melanie S. Griffin, Secretary



STATE OF FLORIDA  
DEPARTMENT OF BUSINESS AND PROFESSIONAL REGULATION

CONSTRUCTION INDUSTRY LICENSING BOARD

THE GENERAL CONTRACTOR HEREIN IS CERTIFIED UNDER THE  
PROVISIONS OF CHAPTER 489, FLORIDA STATUTES



**HOULLIS, ANTHONY MICHAEL**

RAZORBACK LLC  
177 ANCLOTE RD  
TARPOON SPRINGS FL 34689

LICENSE NUMBER: CGC1526612

EXPIRATION DATE: AUGUST 31, 2024

Always verify licenses online at [MyFloridaLicense.com](http://MyFloridaLicense.com)



Do not alter this document in any form.

This is your license. It is unlawful for anyone other than the licensee to use this document.

**RAZORBACK LLC - EQUIPMENT LIST**

**Last Modified 8/14/22**

<b>ID #</b>	<b>Status</b>	<b>Type</b>	<b>Year</b>	<b>Make</b>	<b>Model</b>
001	In Use	Trailer Enclosed	2019	ARNI	16x7x7h
002	In Use	Trailer Enclosed	2016	EAGL	16x7x6.5h
003	In Use	Trailer Enclosed	2018	QLCG	20x8.5x7h
004	In Use	Trailer Gooseneck	2003	CHAMPION	30x8
005	In Use	Trailer Open	2021	TCTC (Triple Crown)	24x7
006	In Use	Trailer Enclosed	2021	Cove (Covered Wagon)	24x8.5x7h
007	In Use	Trailer Enclosed	2020	ISO GA CARGO (SGAC)	14x7x7h
008	In Use	Trailer	2022	Homemade Pontoon Trail	24x8
009		Trailer	1996	USAT	TL
100		Truck	1990	Ford F800 (Blue)	TK
101		Truck	2017	Ford F-450 (Black)	TK Diesel
102		Trailer	1970	Homemade 25'	TV
103	In Use	Trailer	2001	CNTR	TL
104					
105	In Use	Blast Pot	1999	8-Ton With Dryer (#1)	Trailer 4 Shoe
106		Blast Pot	1985	6-Ton (#2)	Skid 2 Shoe
107		Blast Pot	1994	6-Ton (#3)	Skid 4 Shoe Key
108		Blast Pot		Small 8cf	Roller 1 Shoe Key
109					
110		Dust Collector	1996	Blast Tech - ASPT	45000 cfm
111		VACUUM			
112					
113		Paint Pump	2016	Graco Pneumatic	Xtreme NXT X60
114		Paint Pump		Graco Pneumatic	
115					
116					
117		Paint Pump	2018	Graco Gas	GH833
118		Air Compressor	1999	Ingersol Rand	375 CFM
119		Air Compressor		Sullair	375 CFM
120		Air Compressor	2008	Sullair	375 CFM
121		Air Compressor	2012	Sullair	375 CFM
122		Air Compressor	2006	Sullair	300 CFM
123					
124		Blast Pot	1999	Schmit	8 Ton
125		Air Drier	2001	Van Air	1600 CFM
126		Welder	Miller	Bobcat	
127		Concrete Pump		Quickspray	5210
128		DRYER		2100 CFM	SKID MOUNT
129		FORKLIFT		CATIPILLAR 8K	
130		SCISSOR LIFT		SKYJACK	SJII 3219
131					
132					
133		BOAT	2020	Rabco Fliver	8'
134		BARGE			30X12
135		BOAT		PONTOON BOAT	24X8



177 Anclote Road  
 Tarpon Springs, FL 34689  
 (727) 958-9500  
 info@razorbackllc.com  
 razorbackllc.com

**Similar Projects**

1.

<b>Project Owner</b>	National Park Service
<b>Contact Name</b>	William Vazquez
<b>Contact Email</b>	William_vazquez@nps.gov
<b>Contact Phone #</b>	(305) 242-7793
<b>Project Value</b>	\$805,5000
<b>Contract Completion Date</b>	02/01/2021

Scope of Work: includes labor, materials, and equipment to rehabilitate the Flamingo Wastewater Treatment Plant. Work involved selective demolition, sludge removal, structural steel repairs, surface preparation, painting both interior & exterior walls of the membrane bioreactor and membrane treatment tanks, repaired steel piping, concrete form & pour, installing a sluice gate & actuators, replacing valves & flow systems, repairs to existing jet air systems, grouting, and patching using surfacing epoxy to repair voids/pits. Electrical improvements This consisted of the feeder power system and connections to motors, the installation of Instrumentation and Wiring Systems, the replacement of conduits and electrical wiring, the replacement of the panel air conditioning systems, all Bonding & grounding required, and the installation of new magnetic flow meters. Following installation, the new system was integrated with the existing control panel.

2.

<b>Project Owner</b>	City of Winter Haven
<b>Contact Name</b>	Terry Carver
<b>Contact Email</b>	tcarver@mywinterhaven.com
<b>Contact Phone #</b>	(863) 291-5766
<b>Project Value</b>	\$159,200
<b>Contract Completion Date</b>	09/11/2020

Scope of Work: Removed existing Clarifier Drive, cleaned and installed a new Clarifier Drive, surface preparation, sealed expansion joints and cracks, sludge removal, renewed gel coat on fiberglass reinforced plastic weirs and scum baffles, leveled weirs, inlet baffle ring, skimmers, and sludge collector arms, tested & adjusted torque switches for drive protection and painting & coating all new surfaces installed, existing steel surfaces within clarifier, and painting the concrete tank walls and concrete weir troughs.

3.

<b>Project Owner</b>	City of Atlantic Beach
<b>Contact Name</b>	Troy Stephens
<b>Contact Email</b>	tstephens@coab.us
<b>Contact Phone #</b>	(904) 588-4503
<b>Project Value</b>	\$168,900
<b>Contract Completion Date</b>	07/14/2021

Scope of Work: Removed the existing clarifier drives, clarifier bridges and associated hardware, and installed the new clarifier drives along with any necessary new hardware. Also, pressure washed, cleaned, and recoated the catwalk/bridge components at both clarifiers using Tnemec products.

RAZORBACK LLC | NO LIMIT

177 Anclote Road  
Tarpon Springs, FL 34689  
(727) 938-9500  
info@razorbackllc.com  
razorbackllc.com

# Daniel Dion

Lead Project Manager

E-mail: dan@razorbackllc.com

Cell: 727.312.6694

## ***Professional Summary***

---

Results-driven professional with 10+ years experience managing construction projects. Focused on establishing an open and clear line of communication with clients and team members to deliver timely and accurate project completion. Proven track record successfully managing all phases of projects. Ensures safety compliance, administers budgets, controls expenses, and boosts efficiency and productivity.

## ***Skills***

---

- Leadership
- Communication
- Logistics
- Strategic Planning
- Negotiation
- Project Safety
- Estimating
- Organization
- Adaptability
- Problem Solving

## ***Experience***

---

### **Razorback LLC • Lead Project Manager • 2021 to Present**

- Managing complete life cycle of projects- from planning to completion
- Coordinating project schedules to maximize efficiency and mitigate costs
- Ensuring site safety compliance
- Communicating with Owners to ensure client satisfaction

## ***Education***

---

University of Rhode Island • 2001



177 Anclote Road  
Tarpon Springs, FL 34689  
(727) 938-9500  
info@razorbackllc.com  
razorbackllc.com

### **Scope of Work Qualifications**

Licensed as a general contractor in Florida since 2008, Razorback LLC has provided high quality, precision, performance, and delivery of services under contract for over 100 construction-related projects throughout the United States. Providing fabrication, installation, protective and high-performance coating systems, surface preparation, and inspection services to industrial, commercial, and government entities on a multitude of surface types such as iron, aluminum, stucco, concrete, masonry, structural steel, etc. Our projects focus on infrastructure restoration, ranging from minor and major repairs to continuous service agreements with projects that have included roads, bridges, and water and wastewater treatment plants.

Comprised of nationally Certified Safety and Quality Control experts, the Razorback Team utilizes the diverse experience of each employee to develop innovative strategies for each project. Our highly trained AWS-certified welders/pipefitters as well as our SSPC and NACE-certified coating applicators have extensive experience on projects such as this one and have developed a reputation as a leader in quality ensuring successful results on time and within budget.

# FORM 4

## VENDOR REFERENCE FORM

City of Hollywood Solicitation #: 038-23-JJ  
 Reference for: Razorback LLC

Organization/Firm Name providing reference: City of St. Petersburg  
 Organization/Firm Contact Name: Robert L. Ecklund Title: Construction Inspector  
 Email: Robert.Ecklund@stpete.org Phone: (727) 244-7269  
 Name of Referenced Project: Washington Terrace Tank Nos. 1 & 4 - Water Tanks Painting & Repair FY2018 Contract No: 18112-111  
 Date Services were provided: 09/27/2021- 03/02/2022 Project Amount: \$895,115  
 Referenced Vendor's role in Project:  Prime Vendor  Subcontractor/ Subconsultant  
 Would you use the Vendor again?  Yes  No. Please specify in additional comments

**Description of services provided by Vendor (provide additional sheet if necessary):**  
 Power washing entire exterior surfaces and appurtenances, removed lead based paint on exterior shell, surface preparation on both tanks and appurtenances including overflow box and piping, removed and replaced stainless steel brackets and fasteners, applied caulking to all laps, joints, gaps, and connections, removed & replaced interior ladder including rungs, rails and supports and applied coating system to both tanks.

Please rate your experience with the Vendor	Need Improvement	Satisfactory	Excellent	Not Applicable
<b>Vendor's Quality of Service</b>				
a. Responsive	<input type="checkbox"/>	<input type="checkbox"/>	<input checked="" type="checkbox"/>	<input type="checkbox"/>
b. Accuracy	<input type="checkbox"/>	<input type="checkbox"/>	<input checked="" type="checkbox"/>	<input type="checkbox"/>
c. Deliverables	<input type="checkbox"/>	<input type="checkbox"/>	<input checked="" type="checkbox"/>	<input type="checkbox"/>
<b>Vendor's Organization:</b>				
a. Staff expertise	<input type="checkbox"/>	<input type="checkbox"/>	<input checked="" type="checkbox"/>	<input type="checkbox"/>
b. Professionalism	<input type="checkbox"/>	<input type="checkbox"/>	<input checked="" type="checkbox"/>	<input type="checkbox"/>
c. Staff turnover	<input type="checkbox"/>	<input type="checkbox"/>	<input checked="" type="checkbox"/>	<input type="checkbox"/>
<b>Timeliness/Cost Control of:</b>				
a. Project	<input type="checkbox"/>	<input type="checkbox"/>	<input checked="" type="checkbox"/>	<input type="checkbox"/>
b. Deliverables	<input type="checkbox"/>	<input type="checkbox"/>	<input checked="" type="checkbox"/>	<input type="checkbox"/>

**Additional Comments (provide additional sheet if necessary):**  
 Contractor met or exceeded the contract specifications; all restorations was done promptly, and I would look forward to working with them again.

****THIS SECTION FOR CITY USE ONLY****						
Verified via:	Email:	<input type="checkbox"/>	Verbal:	<input type="checkbox"/>	Mail:	<input type="checkbox"/>
Verified by:	Name:				Title:	
	Department:				Date:	

# FORM 4

## VENDOR REFERENCE FORM

City of Hollywood Solicitation #: 038-23-JJ  
 Reference for: Razorback LLC

Organization/Firm Name providing reference: City of Dunedin  
 Organization/Firm Contact Name: Brian Antonian Title: Plant Superintendent  
 Email: bantonian@dunedinfl.net Phone: (727) 298-3249 X 1620  
 Name of Referenced Project: Rehabbing Belcher/Curlew/Jerry Lake Pump Stations Contract No: \_\_\_\_\_  
 Date Services were provided: 05/12/2021- 05/25/2021 Project Amount: \$39,900  
 Referenced Vendor's role in Project:  Prime Vendor  Subcontractor/ Subconsultant  
 Would you use the Vendor again?  Yes  No. Please specify in additional comments

Description of services provided by Vendor (provide additional sheet if necessary):  
 Exterior surface prep and coatings ductile iron pipe located at 3 different locations. Surface prep included pressure washing and degreasing to remove contaminants, power tool and hand tool to remove rusted/bare areas. Also, spot blasting and spot priming.

Please rate your experience with the Vendor	Need Improvement	Satisfactory	Excellent	Not Applicable
<b>Vendor's Quality of Service</b>				
a. Responsive	<input type="checkbox"/>	<input type="checkbox"/>	<input checked="" type="checkbox"/>	<input type="checkbox"/>
b. Accuracy	<input type="checkbox"/>	<input type="checkbox"/>	<input checked="" type="checkbox"/>	<input type="checkbox"/>
c. Deliverables	<input type="checkbox"/>	<input type="checkbox"/>	<input checked="" type="checkbox"/>	<input type="checkbox"/>
<b>Vendor's Organization:</b>				
a. Staff expertise	<input type="checkbox"/>	<input type="checkbox"/>	<input checked="" type="checkbox"/>	<input type="checkbox"/>
b. Professionalism	<input type="checkbox"/>	<input type="checkbox"/>	<input checked="" type="checkbox"/>	<input type="checkbox"/>
c. Staff turnover	<input type="checkbox"/>	<input type="checkbox"/>	<input checked="" type="checkbox"/>	<input type="checkbox"/>
<b>Timeliness/Cost Control of:</b>				
a. Project	<input type="checkbox"/>	<input type="checkbox"/>	<input checked="" type="checkbox"/>	<input type="checkbox"/>
b. Deliverables	<input type="checkbox"/>	<input type="checkbox"/>	<input checked="" type="checkbox"/>	<input type="checkbox"/>

Additional Comments (provide additional sheet if necessary):  
*RAZORBACK DID A FANTASTIC JOB, you will not be disappointed. Excellent work, great workers.*  
*Brian Antonian 1/30/2023*

****THIS SECTION FOR CITY USE ONLY****						
Verified via:	Email:	<input type="checkbox"/>	Verbal:	<input type="checkbox"/>	Mail:	<input type="checkbox"/>
Verified by:	Name:			Title:		
	Department:			Date:		



# FORM 4

## VENDOR REFERENCE FORM

City of Hollywood Solicitation #: 038-23-JJ  
 Reference for: Razorback LLC

Organization/Firm Name providing reference: National Park Service  
 Organization/Firm Contact Name: William Vazquez Title: Contracting Officer  
 Email: william\_vazquez@nps.gov Phone: (305) 242-7793  
 Name of Referenced Project: Rehabilitate Everglades Flamingo Wastewater Treatment Plant Contract No: 140P5420C0016  
 Date Services were provided: 09/01/2020- 02/01/2021 Project Amount: \$805,500  
 Referenced Vendor's role in Project:  Prime Vendor  Subcontractor/ Subconsultant  
 Would you use the Vendor again?  Yes  No. Please specify in additional comments

**Description of services provided by Vendor (provide additional sheet if necessary):**  
 Selective demolition, sludge removal, structural steel repairs to the membrane bioreactor & membrane treatment tank, steel piping repairs, concrete form & pour, installing a sluice gate & actuators, replacing valves & flow system, interior & exterior tank surface blast cleaning, newly fabricated aluminum staircase, electrical improvements and coating systems applied.

Please rate your experience with the Vendor	Need Improvement	Satisfactory	Excellent	Not Applicable
<b>Vendor's Quality of Service</b>				
a. Responsive	<input type="checkbox"/>	<input type="checkbox"/>	<input checked="" type="checkbox"/>	<input type="checkbox"/>
b. Accuracy	<input type="checkbox"/>	<input type="checkbox"/>	<input checked="" type="checkbox"/>	<input type="checkbox"/>
c. Deliverables	<input type="checkbox"/>	<input type="checkbox"/>	<input checked="" type="checkbox"/>	<input type="checkbox"/>
<b>Vendor's Organization:</b>				
a. Staff expertise	<input type="checkbox"/>	<input type="checkbox"/>	<input checked="" type="checkbox"/>	<input type="checkbox"/>
b. Professionalism	<input type="checkbox"/>	<input type="checkbox"/>	<input checked="" type="checkbox"/>	<input type="checkbox"/>
c. Staff turnover	<input type="checkbox"/>	<input type="checkbox"/>	<input type="checkbox"/>	<input checked="" type="checkbox"/>
<b>Timeliness/Cost Control of:</b>				
a. Project	<input type="checkbox"/>	<input type="checkbox"/>	<input checked="" type="checkbox"/>	<input type="checkbox"/>
b. Deliverables	<input type="checkbox"/>	<input type="checkbox"/>	<input checked="" type="checkbox"/>	<input type="checkbox"/>

**Additional Comments (provide additional sheet if necessary):**  
 The contractor was very responsive and worked efficiently and diligently until project completion. I would recommend this contractor for future projects.

****THIS SECTION FOR CITY USE ONLY****						
Verified via:	Email:	<input type="checkbox"/>	Verbal:	<input type="checkbox"/>	Mail:	<input type="checkbox"/>
Verified by:	Name:				Title:	
	Department:				Date:	

# FORM 4

## VENDOR REFERENCE FORM

City of Hollywood Solicitation #: 038-23-JJ  
 Reference for: Razorback LLC

Organization/Firm Name providing reference: City of West Palm Beach  
 Organization/Firm Contact Name: Sandra Feliciano Title: WTP Operations Coordinator  
 Email: SFeliciano@wpb.org Phone: (561) 718-7900  
 Name of Referenced Project: Master Water Storage Tank Cleaning and Repair Services Contract No: 18-19-115  
 Date Services were provided: 05/28/2019- Ongoing (Term) Project Amount: \$501,445.16  
 Referred Vendor's role in Project:  Prime Vendor  Subcontractor/ Subconsultant  
 Would you use the Vendor again?  Yes  No. Please specify in additional comments

**Description of services provided by Vendor (provide additional sheet if necessary):**  
 Cleaning, surface prep and coating services to multiple storage tanks. Work included pressure washing both steel and concrete tanks, disinfecting, baffle curtain repairs, cables replaced, Dome telemetry repairs, Dome void repairs, spalling repairs, interior surface repairs and replacements, interior piping sandblasting, and coating.

Please rate your experience with the Vendor	Need Improvement	Satisfactory	Excellent	Not Applicable
<b>Vendor's Quality of Service</b>				
a. Responsive	<input type="checkbox"/>	<input checked="" type="checkbox"/>	<input type="checkbox"/>	<input type="checkbox"/>
b. Accuracy	<input type="checkbox"/>	<input checked="" type="checkbox"/>	<input type="checkbox"/>	<input type="checkbox"/>
c. Deliverables	<input type="checkbox"/>	<input checked="" type="checkbox"/>	<input type="checkbox"/>	<input type="checkbox"/>
<b>Vendor's Organization:</b>				
a. Staff expertise	<input type="checkbox"/>	<input type="checkbox"/>	<input checked="" type="checkbox"/>	<input type="checkbox"/>
b. Professionalism	<input type="checkbox"/>	<input type="checkbox"/>	<input checked="" type="checkbox"/>	<input type="checkbox"/>
c. Staff turnover	<input type="checkbox"/>	<input type="checkbox"/>	<input type="checkbox"/>	<input checked="" type="checkbox"/>
<b>Timeliness/Cost Control of:</b>				
a. Project	<input type="checkbox"/>	<input type="checkbox"/>	<input checked="" type="checkbox"/>	<input type="checkbox"/>
b. Deliverables	<input type="checkbox"/>	<input type="checkbox"/>	<input checked="" type="checkbox"/>	<input type="checkbox"/>

**Additional Comments (provide additional sheet if necessary):**  
*Sandra Feliciano 2/3/2023*  
*City of West Palm Beach, WTP Operations Coordinator*

****THIS SECTION FOR CITY USE ONLY****						
Verified via:	Email:	<input type="checkbox"/>	Verbal:	<input type="checkbox"/>	Mail:	<input type="checkbox"/>
Verified by:	Name:				Title:	
	Department:				Date:	

## FORM 7

### SWORN STATEMENT PURSUANT TO SECTION 287.133 (3) (a) FLORIDA STATUTES ON PUBLIC ENTITY CRIMES

THIS FORM MUST BE SIGNED AND SWORN TO IN THE PRESENCE OF A NOTARY PUBLIC OR OTHER OFFICIAL AUTHORIZED TO ADMINISTER OATHS

1. This form statement is submitted to the City of Hollywood by Anthony Houllis, MGRM for Razorback LLC  
(Print individual's name and title) (Print name of entity submitting sworn statement)  
whose business address is 177 Anclote Road, Tarpon Springs, FL 34689  
and if applicable its Federal Employer Identification Number (FEIN) is 26-3447303. If the entity has no FEIN, include the Social Security Number of the individual signing this sworn statement.
- 

2. I understand that "public entity crime," as defined in paragraph 287.133(1)(g), Florida Statutes, means a violation of any state or federal law by a person with respect to and directly related to the transaction of business with any public entity or with an agency or political subdivision of any other state or with the United States, including, but not limited to, any bid, proposal, reply, or contract for goods or services, any lease for real property, or any contract for the construction or repair of a public building or public work, involving antitrust, fraud, theft, bribery, collusion, racketeering, conspiracy, or material misinterpretation.
3. I understand that "convicted" or "conviction" as defined in Paragraph 287.133(1)(b), Florida Statutes, means a finding of guilt or a conviction of a public entity crime, with or without an adjudication of guilt, in an federal or state trial court of record relating to charges brought by indictment or information after July 1, 1989, as a result of a jury verdict, nonjury trial, or entry of a plea of guilty or nolo contendere.
4. I understand that "Affiliate," as defined in paragraph 287.133(1)(a), Florida Statutes, means:
1. A predecessor or successor of a person convicted of a public entity crime, or
  2. An entity under the control of any natural person who is active in the management of the entity and who has been convicted of a public entity crime. The term "affiliate" includes those officers, directors, executives, partners, shareholders, employees, members, and agents who are active in the management of an affiliate. The ownership by one person of shares constituting a controlling interest in another person, or a pooling of equipment or income among persons when not for fair market value under an arm's length agreement, shall be a prima facie case that one person controls another person. A person who knowingly enters into a joint venture with a person who has been convicted of a public entity crime in Florida during the preceding 36 months shall be considered an affiliate.
- 5 I understand that "person," as defined in Paragraph 287.133(1)(e), Florida Statutes, means any natural person or any entity organized under the laws of any state or of the

United States with the legal power to enter into a binding contract and which bids or applies to bid on contracts let by a public entity, or which otherwise transacts or applies to transact business with a public entity. The term "person" includes those officers, executives, partners, shareholders, employees, members, and agents who are active in management of an entity.

6. Based on information and belief, the statement which I have marked below is true in relation to the entity submitting this sworn statement. (Please indicate which statement applies.)

X  Neither the entity submitting sworn statement, nor any of its officers, director, executives, partners, shareholders, employees, members, or agents who are active in the management of the entity, nor any affiliate of the entity has been charged with and convicted of a public entity crime subsequent to July 1, 1989.

The entity submitting this sworn statement, or one or more of its officers, directors, executives, partners, shareholders, employees, members, or agents who are active in the management of the entity, or an affiliate of the entity, or an affiliate of the entity has been charged with and convicted of a public entity crime subsequent to July 1, 1989.

The entity submitting this sworn statement, or one or more of its officers, directors, executives, partners, shareholders, employees, members, or agents who are active in the management of the entity, or an affiliate of the entity has been charged with and convicted of a public entity crime, but the Final Order entered by the Hearing Officer in a subsequent proceeding before a Hearing Officer of the State of the State of Florida,

Division of Administrative Hearings, determined that it was not in the public interest to place the entity submitting this sworn statement on the convicted vendor list. (attach a copy of the Final Order).

I UNDERSTAND THAT THE SUBMISSION OF THIS FORM TO THE CONTRACTING OFFICER FOR THE PUBLIC ENTITY IDENTIFIED IN PARAGRAPH 1 (ONE) ABOVE IS FOR THAT PUBLIC ENTITY ONLY AND THAT THIS FORM IS VALID THROUGH DECEMBER 31 OF THE CALENDAR YEAR IN WHICH IT IS FILED. I ALSO UNDERSTAND THAT I AM REQUIRED TO INFORM THAT PUBLIC ENTITY PRIOR TO ENTERING INTO A CONTRACT IN EXCESS OF THE THRESHOLD AMOUNT PROVIDED IN SECTION 287.017 FLORIDA STATUTES FOR A CATEGORY TWO OF ANY CHANGE IN THE INFORMATION CONTAINED IN THIS FORM.

ASHL   
(Signature)

Sworn to and subscribed before me this  8th  day of  February , 20 23 .

Personally known  Anthony Houllis

Or produced identification \_\_\_\_\_ Notary Public-State of  Florida

\_\_\_\_\_ my commission expires \_\_\_\_\_  
(Type of identification)



Heather B. Stamas  
Comm. #GG353611  
Expires: July 10, 2023  
Bonded Thru Aaron Notary

Heather B. Stamas   
Printed, typed or stamped commissioned name of notary public

Heather B. Stamas

# Request for Taxpayer Identification Number and Certification

Give Form to the requester. Do not send to the IRS.

▶ Go to [www.irs.gov/FormW9](http://www.irs.gov/FormW9) for instructions and the latest information.

See Specific Instructions on page 3.

**1** Name (as shown on your income tax return). Name is required on this line; do not leave this line blank.  
**RAZORBACK LLC**

**2** Business name/disregarded entity name, if different from above

**3** Check appropriate box for federal tax classification of the person whose name is entered on line 1. Check only **one** of the following seven boxes.

Individual/sole proprietor or single-member LLC

C Corporation

S Corporation

Partnership

Trust/estate

Limited liability company. Enter the tax classification (C=C corporation, S=S corporation, P=Partnership) ▶ **S**

**Note:** Check the appropriate box in the line above for the tax classification of the single-member owner. Do not check LLC if the LLC is classified as a single-member LLC that is disregarded from the owner unless the owner of the LLC is another LLC that is **not** disregarded from the owner for U.S. federal tax purposes. Otherwise, a single-member LLC that is disregarded from the owner should check the appropriate box for the tax classification of its owner.

Other (see instructions) ▶

**4** Exemptions (codes apply only to certain entities, not individuals; see instructions on page 3):

Exempt payee code (if any) \_\_\_\_\_

Exemption from FATCA reporting code (if any) \_\_\_\_\_

(Applies to accounts maintained outside the U.S.)

**5** Address (number, street, and apt. or suite no.) See instructions.  
**177 ANCLOTE ROAD**

**6** City, state, and ZIP code  
**TARPON SPRINGS, FL 34689**

**7** List account number(s) here (optional)

Requester's name and address (optional)

## Part I Taxpayer Identification Number (TIN)

Enter your TIN in the appropriate box. The TIN provided must match the name given on line 1 to avoid backup withholding. For individuals, this is generally your social security number (SSN). However, for a resident alien, sole proprietor, or disregarded entity, see the instructions for Part I, later. For other entities, it is your employer identification number (EIN). If you do not have a number, see *How to get a TIN*, later.

**Note:** If the account is in more than one name, see the instructions for line 1. Also see *What Name and Number To Give the Requester* for guidelines on whose number to enter.

**Social security number**

				-					
--	--	--	--	---	--	--	--	--	--

or

**Employer identification number**

2	6	-	3	4	4	7	3	0	3
---	---	---	---	---	---	---	---	---	---

## Part II Certification

Under penalties of perjury, I certify that:

- The number shown on this form is my correct taxpayer identification number (or I am waiting for a number to be issued to me); and
- I am not subject to backup withholding because: (a) I am exempt from backup withholding, or (b) I have not been notified by the Internal Revenue Service (IRS) that I am subject to backup withholding as a result of a failure to report all interest or dividends, or (c) the IRS has notified me that I am no longer subject to backup withholding; and
- I am a U.S. citizen or other U.S. person (defined below); and
- The FATCA code(s) entered on this form (if any) indicating that I am exempt from FATCA reporting is correct.

**Certification instructions.** You must cross out item 2 above if you have been notified by the IRS that you are currently subject to backup withholding because you have failed to report all interest and dividends on your tax return. For real estate transactions, item 2 does not apply. For mortgage interest paid, acquisition or abandonment of secured property, cancellation of debt, contributions to an individual retirement arrangement (IRA), and generally, payments other than interest and dividends, you are not required to sign the certification, but you must provide your correct TIN. See the instructions for Part II, later.

**Sign Here** Signature of U.S. person ▶  Date ▶ **2-10-21**

## General Instructions

Section references are to the Internal Revenue Code unless otherwise noted.

**Future developments.** For the latest information about developments related to Form W-9 and its instructions, such as legislation enacted after they were published, go to [www.irs.gov/FormW9](http://www.irs.gov/FormW9).

## Purpose of Form

An individual or entity (Form W-9 requester) who is required to file an information return with the IRS must obtain your correct taxpayer identification number (TIN) which may be your social security number (SSN), individual taxpayer identification number (ITIN), adoption taxpayer identification number (ATIN), or employer identification number (EIN), to report on an information return the amount paid to you, or other amount reportable on an information return. Examples of information returns include, but are not limited to, the following.

- Form 1099-INT (interest earned or paid)

- Form 1099-DIV (dividends, including those from stocks or mutual funds)
  - Form 1099-MISC (various types of income, prizes, awards, or gross proceeds)
  - Form 1099-B (stock or mutual fund sales and certain other transactions by brokers)
  - Form 1099-S (proceeds from real estate transactions)
  - Form 1099-K (merchant card and third party network transactions)
  - Form 1098 (home mortgage interest), 1098-E (student loan interest), 1098-T (tuition)
  - Form 1099-C (canceled debt)
  - Form 1099-A (acquisition or abandonment of secured property)
- Use Form W-9 only if you are a U.S. person (including a resident alien), to provide your correct TIN.

If you do not return Form W-9 to the requester with a TIN, you might be subject to backup withholding. See What is backup withholding, later.

# FORM 12

## TRENCH SAFETY

This form must be completed and signed by the Respondent.

Failure to complete this form may result in the solicitation being declared non-responsive.

Respondent acknowledges that the Florida Trench Safety Act, Section 553.60 et. seq., which became effective October 1, 1990, shall be in effect during the period of construction of the project. The respondent by signing and submitting the solicitation is, in writing, assuring that it will perform any trench excavation in accordance with applicable trench safety standards. The respondent further identifies the following separate item of cost of compliance with the applicable trench safety standards as well as the method of compliance:

<u>Method of Compliance</u>	<u>Cost</u>
-	\$0
Total \$	<u>0</u>

Respondent acknowledges that this cost is included in the applicable items of their submittal and in the Grand Total Solicitation Price. Failure to complete the above will result in the solicitation being declared non-responsive.

The Respondent is, and the Owner and Engineer are not, responsible to review or assess Respondent's safety precautions, programs or costs, or the means, methods, techniques or technique adequacy, reasonableness of cost, sequences or procedures of any safety precaution, program or cost, including but not limited to, compliance with any and all requirements of Florida Statute Section 553.60 et. seq. cited as the "Trench Safety Act." Respondent is, and the owner and Engineer are not, responsible to determine if any safety related standards apply to the project, including but not limited to, the "Trench Safety Act."

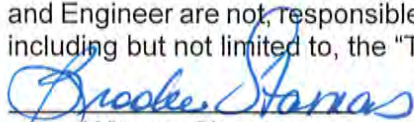
  
Witness Signature

Brooke Stamas  
Witness Printed Name

177 Anclote Road, Tarpon Springs, FL 34689

Witness Address

02/08/2023  
Date

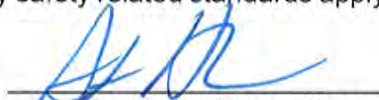
  
Contractor's Signature

Anthony Houllis  
Printed Name

MGRM  
Title

02/08/2023  
Date

- END OF SECTION -

**Form 13****Bid Guaranty Form**

(Construction)

STATE OF FLORIDA

KNOW ALL MEN BY THESE PRESENTS:

That we Razorback, LLC, as Principal, and The Gray Insurance Company as

Surety, are held and firmly bound unto the City of Hollywood in the sum of Forty Six  
Thousand Eight Hundred Ten and Fifty cents Dollars (\$ 46,810.50 ) lawful money  
of the United States, amounting to 5% of the total SOLICITATION Price, for the payment of said  
sum, we bind ourselves, our heirs, executors, administrators, and successors, jointly and  
severally, firmly by these presents.

THE CONDITION OF THIS OBLIGATION IS SUCH, that whereas the principal has submitted the  
accompanying SOLICITATION, dated \_\_\_\_\_ February 23, 20<sup>23</sup> for

**CLARIFIER NO. 3 REPAIR****Bid No. REQ-038-23-JJ**

NOW, THEREFORE, if the principal shall not withdraw said SOLICITATION within 90 days after  
date of the same and shall within ten days after the prescribed forms are presented to him for  
signature, enter into a written contract with the CITY, in accordance with the SOLICITATION as  
accepted, and give bond with good and sufficient surety or sureties, and provide the necessary  
Insurance Certificates as may be required for the faithful performance and proper fulfillment of  
such Contract, then this obligation shall be null and void.

Approved SOLICITATION Bond

In the event of the withdrawal of said SOLICITATION within the specified period, or the failure to enter into such contract and give such bond and insurance within the specified time, the principal and the surety shall pay to the City of Hollywood the difference between the amount specified in said SOLICITATION and such larger amount for which the City of Hollywood may in good faith contract with another party to perform the work and/or supply the materials covered by said SOLICITATION.

IN WITNESS WHEREOF, the above bound parties have executed this statement under their several seals this 23rd day of February, 201, the name and corporate seal of each corporate party being hereto affixed and these presents duly signed by its undersigned representative, pursuant to authority of its governing body. \*23

WHEN THE PRINCIPAL IS AN INDIVIDUAL:

Signed, sealed and delivered in the presence of:

N/A  
Witness

N/A  
Signature of Individual

N/A  
Address

N/A

N/A  
Printed Name of Individual

N/A  
Witness

N/A  
Address

N/A



WHEN THE PRINCIPAL IS A CORPORATION:

Attest:

*Brooke Stamas*  
Secretary WITNESS

Razorback, LLC  
Name of Corporation

177 Anclote Road  
Business Address

Tarpon Springs, FL 34689

By: *AH*  
(Affix Corporate Seal)

ANTHONY HOULLIS  
Printed Name

MGRM  
Official Title



CERTIFICATE AS TO CORPORATE PRINCIPAL

I, *AH*, certify that I am the <sup>MGRM</sup> ~~secretary~~ of the ~~LLC - Corporation~~ named as Principal in the attached bond; that ANTHONY HOULLIS who signed the said bond on behalf of the Principal, was then MGRM of said Corporation; that I know his signature, and his signature thereto is genuine and that said bond was duly signed, sealed and attested for and on behalf of said Corporation by authority of its governing body.

*AH* (SEAL)  
Secretary MGRM

Approved SOLICITATION Bond

TO BE EXECUTED BY CORPORATE SURETY:

Attest:

Susan L Reich  
Secretary Susan L. Reich

The Gray Insurance Company  
Corporate Surety  
PO Box 6202  
Business Address  
Metairie, LA 70009-6202

BY: Gloria A Richards  
(Affix Corporate Seal) Gloria A. Richards  
Attorney-In-Fact &  
FL Lic. Resident Agent

Gloria A. Richards, Attorney-In-Fact & FL Lic. Resident Agent  
Attorney-in-Fact  
Florida Surety Bonds, Inc.  
620 N. Wymore Rd., Suite 200, Maitland, FL 32751  
Business Address  
407-786-7770

Name of Local Agency

STATE OF FLORIDA

Before me, a Notary Public, duly commissioned, qualified and acting, personally appeared,  
Gloria A. Richards to me well known, who being by me first duly sworn upon  
oath says that he\*is the attorney-in-fact for the The Gray Insurance Company and  
that the has been authorized by The Gray Insurance Company to execute the forgoing  
bond on behalf of the CONTRACTOR named therein in favor of the City of Hollywood, Florida.  
Subscribed and sworn to before me this 23rd day of February, 2023

Elizabeth Luu Karoly  
Elizabeth Luu Karoly Notary Public, State of Florida

My Commission Expires: 07/09/2026

- END OF SECTION-

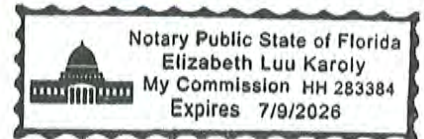

\*/she

**THE GRAY INSURANCE COMPANY  
THE GRAY CASUALTY & SURETY COMPANY**

**GENERAL POWER OF ATTORNEY**

**Bond Number:** N/A                      **Principal:** Razorback, LLC  
**Project:** Bid No. REQ-038-23-JJ; Clarifier No. 3 Repair, City of Hollywood, FL

KNOW ALL BY THESE PRESENTS, THAT The Gray Insurance Company and The Gray Casualty & Surety Company, corporations duly organized and existing under the laws of Louisiana, and having their principal offices in Metairie, Louisiana, do hereby make, constitute, and appoint: **Susan L. Reich, Jeffrey W. Reich, Kim E. Niv, Teresa L. Durham, Cheryl A. Foley, Gloria A. Richards, Robert P. O'Linn, Sarah K. O'Linn, Lisa A. Roseland, and Emily J. Golecki of Maitland, Florida jointly and severally** on behalf of each of the Companies named above its true and lawful Attorney(s)-in-Fact, to make, execute, seal and deliver, for and on its behalf and as its deed, bonds, or other writings obligatory in the nature of a bond, as surety, contracts of suretyship as are or may be required or permitted by law, regulation, contract or otherwise, provided that no bond or undertaking or contract of suretyship executed under this authority shall exceed the amount of \$25,000,000.00.

This Power of Attorney is granted and is signed by facsimile under and by the authority of the following Resolutions adopted by the Boards of Directors of both The Gray Insurance Company and The Gray Casualty & Surety Company at meetings duly called and held on the 26<sup>th</sup> day of June, 2003.

"RESOLVED, that the President, Executive Vice President, any Vice President, or the Secretary be and each or any of them hereby is authorized to execute a power of Attorney qualifying the attorney named in the given Power of Attorney to execute on behalf of the Company bonds, undertakings, and all contracts of surety, and that each or any of them is hereby authorized to attest to the execution of such Power of Attorney, and to attach the seal of the Company; and it is

FURTHER RESOLVED, that the signature of such officers and the seal of the Company may be affixed to any such Power of Attorney or to any certificate relating thereto by facsimile, and any such Power of Attorney or certificate bearing such facsimile signature or facsimile seal shall be binding upon the Company now and in the future when so affixed with regard to any bond, undertaking or contract of surety to which it is attached.

IN WITNESS WHEREOF, The Gray Insurance Company and The Gray Casualty & Surety Company have caused their official seals to be hereinto affixed, and these presents to be signed by their authorized officers this 4<sup>th</sup> day of November, 2022.



By:

*Michael T. Gray*

Michael T. Gray  
President  
The Gray Insurance Company

*Cullen S. Piske*

Cullen S. Piske  
President  
The Gray Casualty & Surety Company



State of Louisiana  
ss:

Parish of Jefferson  
On this 4<sup>th</sup> day of November, 2022, before me, a Notary Public, personally appeared Michael T. Gray, President of The Gray Insurance Company, and Cullen S. Piske, President of The Gray Casualty & Surety Company, personally known to me, being duly sworn, acknowledged that they signed the above Power of Attorney and affixed the seals of the companies as officers of, and acknowledged said instrument to be the voluntary act and deed, of their companies.



Leigh Anne Henican  
Notary Public  
Notary ID No. 92653  
Orleans Parish, Louisiana

*Leigh Anne Henican*

Leigh Anne Henican  
Notary Public, Parish of Orleans State of Louisiana  
My Commission is for Life

I, Mark S. Manguno, Secretary of The Gray Insurance Company, do hereby certify that the above and forgoing is a true and correct copy of a Power of Attorney given by the companies, which is still in full force and effect. IN WITNESS WHEREOF, I have set my hand and affixed the seals of the Company this 23<sup>rd</sup> day of February, 2023.

*Mark S. Manguno*

I, Leigh Anne Henican, Secretary of The Gray Casualty & Surety Company, do hereby certify that the above and forgoing is a true and correct copy of a Power of Attorney given by the companies, which is still in full force and effect. IN WITNESS WHEREOF, I have set my hand and affixed the seals of the Company this 23<sup>rd</sup> day of February, 2023.

*Leigh Anne Henican*



**Form 14**

**LIST OF SUBCONTRACTORS**

The Respondent shall list below the name and address of each Subcontractor who will perform work under this Contract, and shall also list the portion of the work which will be done by such Subcontractor. After the opening of Submittals, changes or substitutions will be allowed with written approval of the City of Hollywood. Subcontractors must be properly licensed.

	<b>Work to be Performed</b>	<b>Subcontractor's Name / Address</b>
1.	None Anticipated	
2.		
3.		
4.		
5.		
6.		
7.		
8.		
9.		
10.		

NOTE: Attach additional sheets if required.



# CERTIFICATE OF LIABILITY INSURANCE

DATE (MM/DD/YYYY)

08/02/2022

THIS CERTIFICATE IS ISSUED AS A MATTER OF INFORMATION ONLY AND CONFERS NO RIGHTS UPON THE CERTIFICATE HOLDER. THIS CERTIFICATE DOES NOT AFFIRMATIVELY OR NEGATIVELY AMEND, EXTEND OR ALTER THE COVERAGE AFFORDED BY THE POLICIES BELOW. THIS CERTIFICATE OF INSURANCE DOES NOT CONSTITUTE A CONTRACT BETWEEN THE ISSUING INSURER(S), AUTHORIZED REPRESENTATIVE OR PRODUCER, AND THE CERTIFICATE HOLDER.

**IMPORTANT:** If the certificate holder is an ADDITIONAL INSURED, the policy(ies) must have ADDITIONAL INSURED provisions or be endorsed. If SUBROGATION IS WAIVED, subject to the terms and conditions of the policy, certain policies may require an endorsement. A statement on this certificate does not confer rights to the certificate holder in lieu of such endorsement(s).

<b>PRODUCER</b> Stahl & Associates Insurance Inc. 3939 Tampa Road Oldsmar FL 34677		<b>CONTACT NAME:</b> Maribeth Patino <b>PHONE (A/C, No, Ext):</b> (813) 818-5300 <b>E-MAIL ADDRESS:</b> maribeth.patino@stahlinsurance.com <b>FAX (A/C, No):</b> (813) 818-5396	
		<b>INSURER(S) AFFORDING COVERAGE</b>	
		<b>INSURER A:</b> Champlain Specialty Insurance Co	<b>NAIC #</b> 16834
<b>INSURED</b>		<b>INSURER B:</b> Auto Owners Insurance Co	18988
Razorback LLC 177 Anclote Road Tarpon Springs FL 34689		<b>INSURER C:</b> Westchester Surplus Lines Ins Co	10172
		<b>INSURER D:</b>	
		<b>INSURER E:</b>	
		<b>INSURER F:</b>	

**COVERAGES**                      **CERTIFICATE NUMBER:** 22-23 Liab                      **REVISION NUMBER:**

THIS IS TO CERTIFY THAT THE POLICIES OF INSURANCE LISTED BELOW HAVE BEEN ISSUED TO THE INSURED NAMED ABOVE FOR THE POLICY PERIOD INDICATED. NOTWITHSTANDING ANY REQUIREMENT, TERM OR CONDITION OF ANY CONTRACT OR OTHER DOCUMENT WITH RESPECT TO WHICH THIS CERTIFICATE MAY BE ISSUED OR MAY PERTAIN, THE INSURANCE AFFORDED BY THE POLICIES DESCRIBED HEREIN IS SUBJECT TO ALL THE TERMS, EXCLUSIONS AND CONDITIONS OF SUCH POLICIES. LIMITS SHOWN MAY HAVE BEEN REDUCED BY PAID CLAIMS.

INSR LTR	TYPE OF INSURANCE	ADDL INSD	SUBR WVD	POLICY NUMBER	POLICY EFF (MM/DD/YYYY)	POLICY EXP (MM/DD/YYYY)	LIMITS	
A	<input checked="" type="checkbox"/> COMMERCIAL GENERAL LIABILITY			CSARCGL000071101	07/08/2022	07/08/2023	EACH OCCURRENCE	\$ 1,000,000
	<input type="checkbox"/> CLAIMS-MADE <input checked="" type="checkbox"/> OCCUR						DAMAGE TO RENTED PREMISES (Ea occurrence)	\$ 100,000
	GEN'L AGGREGATE LIMIT APPLIES PER:						MED EXP (Any one person)	\$ 5,000
	<input type="checkbox"/> POLICY <input checked="" type="checkbox"/> PRO-JECT <input type="checkbox"/> LOC						PERSONAL & ADV INJURY	\$ 1,000,000
	OTHER:						GENERAL AGGREGATE	\$ 2,000,000
							PRODUCTS - COMP/OP AGG	\$ 2,000,000
								\$
B	<b>AUTOMOBILE LIABILITY</b>			5181816000	06/16/2022	06/16/2023	COMBINED SINGLE LIMIT (Ea accident)	\$ 1,000,000
	<input checked="" type="checkbox"/> ANY AUTO OWNED AUTOS ONLY	<input type="checkbox"/> SCHEDULED AUTOS NON-OWNED AUTOS ONLY					BODILY INJURY (Per person)	\$
	<input type="checkbox"/> HIRED AUTOS ONLY						BODILY INJURY (Per accident)	\$
							PROPERTY DAMAGE (Per accident)	\$
							\$	
A	<input checked="" type="checkbox"/> UMBRELLA LIAB			CSARCEL000071201	07/08/2022	07/08/2023	EACH OCCURRENCE	\$ 2,000,000
	<input type="checkbox"/> EXCESS LIAB	<input checked="" type="checkbox"/> OCCUR <input type="checkbox"/> CLAIMS-MADE						AGGREGATE
	DED	RETENTION \$						\$
	<b>WORKERS COMPENSATION AND EMPLOYERS' LIABILITY</b>						PER STATUTE	OTH-ER
	ANY PROPRIETOR/PARTNER/EXECUTIVE OFFICER/MEMBER EXCLUDED? (Mandatory in NH)	<input type="checkbox"/> Y <input type="checkbox"/> N	N/A				E.L. EACH ACCIDENT	\$
	If yes, describe under DESCRIPTION OF OPERATIONS below						E.L. DISEASE - EA EMPLOYEE	\$
							E.L. DISEASE - POLICY LIMIT	\$
C	Contractor's Pollution Liability			G71154920 005	07/08/2022	07/08/2023	Each Pollution Condition	\$2,000,000
							Aggregate	\$2,000,000

DESCRIPTION OF OPERATIONS / LOCATIONS / VEHICLES (ACORD 101, Additional Remarks Schedule, may be attached if more space is required)

## CERTIFICATE HOLDER

## CANCELLATION

FOR PROPOSAL PURPOSES ONLY

SHOULD ANY OF THE ABOVE DESCRIBED POLICIES BE CANCELLED BEFORE THE EXPIRATION DATE THEREOF, NOTICE WILL BE DELIVERED IN ACCORDANCE WITH THE POLICY PROVISIONS.

AUTHORIZED REPRESENTATIVE

© 1988-2015 ACORD CORPORATION. All rights reserved.



# CERTIFICATE OF LIABILITY INSURANCE

DATE (MM/DD/YYYY)

10/28/2022

THIS CERTIFICATE IS ISSUED AS A MATTER OF INFORMATION ONLY AND CONFERS NO RIGHTS UPON THE CERTIFICATE HOLDER. THIS CERTIFICATE DOES NOT AFFIRMATIVELY OR NEGATIVELY AMEND, EXTEND OR ALTER THE COVERAGE AFFORDED BY THE POLICIES BELOW. THIS CERTIFICATE OF INSURANCE DOES NOT CONSTITUTE A CONTRACT BETWEEN THE ISSUING INSURER(S), AUTHORIZED REPRESENTATIVE OR PRODUCER, AND THE CERTIFICATE HOLDER.

**IMPORTANT:** If the certificate holder is an **ADDITIONAL INSURED**, the policy(ies) must have **ADDITIONAL INSURED** provisions or be endorsed. If **SUBROGATION IS WAIVED**, subject to the terms and conditions of the policy, certain policies may require an endorsement. A statement on this certificate does not confer rights to the certificate holder in lieu of such endorsement(s).

PRODUCER	SUNZ Insurance Solutions, LLC. c/o TLR of Bonita, Inc 700 Central Ave, Suite 500 St. Petersburg, FL 33701	ID: (TLR)	CONTACT NAME:	Workers' Comp Department		
	PHONE (A/C, No, Ext):		727-520-7676 x 3	FAX (A/C, No):	727-525-3862	
			E-MAIL ADDRESS:	certs@encorehr.com		
				INSURER(S) AFFORDING COVERAGE		NAIC #
				INSURER A : SUNZ Insurance Company		34762
INSURED	TLR of Bonita, Inc dba EnterpriseHR 700 Central Avenue Suite 500 St. Petersburg FL 33701			INSURER B :		
				INSURER C :		
				INSURER D :		
				INSURER E :		
				INSURER F :		

**COVERAGES**

CERTIFICATE NUMBER: 71027414

REVISION NUMBER:

THIS IS TO CERTIFY THAT THE POLICIES OF INSURANCE LISTED BELOW HAVE BEEN ISSUED TO THE INSURED NAMED ABOVE FOR THE POLICY PERIOD INDICATED. NOTWITHSTANDING ANY REQUIREMENT, TERM OR CONDITION OF ANY CONTRACT OR OTHER DOCUMENT WITH RESPECT TO WHICH THIS CERTIFICATE MAY BE ISSUED OR MAY PERTAIN, THE INSURANCE AFFORDED BY THE POLICIES DESCRIBED HEREIN IS SUBJECT TO ALL THE TERMS, EXCLUSIONS AND CONDITIONS OF SUCH POLICIES. LIMITS SHOWN MAY HAVE BEEN REDUCED BY PAID CLAIMS.

INSR LTR	TYPE OF INSURANCE	ADDL INSD	SUBR WVD	POLICY NUMBER	POLICY EFF (MM/DD/YYYY)	POLICY EXP (MM/DD/YYYY)	LIMITS
	<b>COMMERCIAL GENERAL LIABILITY</b> <input type="checkbox"/> CLAIMS-MADE <input type="checkbox"/> OCCUR  GEN'L AGGREGATE LIMIT APPLIES PER: <input type="checkbox"/> POLICY <input type="checkbox"/> PROJECT <input type="checkbox"/> LOC OTHER:						EACH OCCURRENCE \$ DAMAGE TO RENTED PREMISES (Ea occurrence) \$ MED EXP (Any one person) \$ PERSONAL & ADV INJURY \$ GENERAL AGGREGATE \$ PRODUCTS - COMP/OP AGG \$ \$
	<b>AUTOMOBILE LIABILITY</b> <input type="checkbox"/> ANY AUTO <input type="checkbox"/> OWNED AUTOS ONLY <input type="checkbox"/> SCHEDULED AUTOS <input type="checkbox"/> HIRED AUTOS ONLY <input type="checkbox"/> NON-OWNED AUTOS ONLY <input type="checkbox"/> AUTOS ONLY						COMBINED SINGLE LIMIT (Ea accident) \$ BODILY INJURY (Per person) \$ BODILY INJURY (Per accident) \$ PROPERTY DAMAGE (Per accident) \$ \$
	<b>UMBRELLA LIAB</b> <input type="checkbox"/> EXCESS LIAB <input type="checkbox"/> OCCUR <input type="checkbox"/> CLAIMS-MADE DED RETENTION \$						EACH OCCURRENCE \$ AGGREGATE \$ \$
A	<b>WORKERS COMPENSATION AND EMPLOYERS' LIABILITY</b> ANY PROPRIETOR/PARTNER/EXECUTIVE OFFICER/MEMBER EXCLUDED? (Mandatory in NH) If yes, describe under DESCRIPTION OF OPERATIONS below	Y/N <input type="checkbox"/>	N/A	WC039-00001-022	6/1/2022	6/1/2023	<input checked="" type="checkbox"/> PER STATUTE <input type="checkbox"/> OTH-ER E.L. EACH ACCIDENT \$ 1,000,000.00 E.L. DISEASE - EA EMPLOYEE \$ 1,000,000.00 E.L. DISEASE - POLICY LIMIT \$ 1,000,000.00

DESCRIPTION OF OPERATIONS / LOCATIONS / VEHICLES (ACORD 101, Additional Remarks Schedule, may be attached if more space is required)

Coverage Provided for all leased employees but not subcontractors of: Razorback LLC  
Client Effective: 09/28/2020

**CERTIFICATE HOLDER**

441  
Razorback LLC  
177 Anclote Road  
Tarpon Springs, FL 34689

**CANCELLATION**

SHOULD ANY OF THE ABOVE DESCRIBED POLICIES BE CANCELLED BEFORE THE EXPIRATION DATE THEREOF, NOTICE WILL BE DELIVERED IN ACCORDANCE WITH THE POLICY PROVISIONS.

AUTHORIZED REPRESENTATIVE

Rick Leonard

© 1988-2015 ACORD CORPORATION. All rights reserved.

FORM 16

PROPOSAL

TO THE MAYOR AND COMMISSIONERS  
CITY OF HOLLYWOOD, FLORIDA

SUBMITTED 02/23/2023

Dear Mayor and Commissioners:

The undersigned, as BIDDER, hereby declares that the only person or persons interested in the Proposal as principal or principals is or are named herein and that no other person than herein mentioned has any interest in this Proposal or in the Contract to be entered into; that this Proposal is made without connection with any other person, company or parties making a Bid or Proposal; and that it is in all respects fair and in good faith without collusion or fraud.

The BIDDER further declares that he has examined the site of the Work and informed himself fully in regard to all conditions pertaining to the place where the Work is to be done; that he has examined the Drawings and Specifications for the Work and contractual documents relative thereto, including the Notice to Bidders, Instructions to Bidders, Proposal Bid Form, Form of Bid Bond, Form of Contract and Form of Performance Bond, General, Supplementary and Technical Specifications, Addenda, Drawings, and Local Preference Program, Exhibit A, and has read all of the Provisions furnished prior to the opening of bids; and that he has satisfied himself relative to the work to be performed.

The undersigned BIDDER has not divulged to, discussed or compared his bid with other bidders and has not colluded with any other BIDDER of parties to this bid whatever.

If this Proposal is accepted, the undersigned BIDDER proposes and agrees to enter into and execute the Contract with the City of Hollywood, Florida, in the form of Contract specified; of which this Proposal, Instructions to Bidders, General Specifications, Supplementary Conditions and Drawings shall be made a part for the performance of Work described therein; to furnish the necessary bond equal to one hundred (100) percent of the total Contract base bid, the said bond being in the form of a Cash Bond or Surety Bond prepared on the applicable approved bond form furnished by the CITY; to furnish all necessary materials, equipment, machinery, tools, apparatus, transportation, supervision, labor and all means necessary to construct and complete the work specified in the Proposal and Contract and called for in the Drawings and in the manner specified; to commence Work on the effective date established in the "Notice to Proceed" from the ENGINEER; and to substantially complete all Contract Work within 30 days with final completion within 45 days, and stated in the "Notice to Proceed" or pay liquidated damages for each calendar day in excess thereof, or such actual and consequential damages as may result therefrom, and to abide by the Local Preference Ordinance, Exhibit A.

The BIDDER acknowledges receipt of the following addenda:

No. <u>1</u>	Dated <u>1/11/23</u>
No. <u>2</u>	Dated <u>2/08/23</u>
No. <u>3</u>	Dated <u>2/15/23</u>
No. <u>4</u>	Dated <u>2/22/23</u>

And the undersigned agrees that in case of failure on his part to execute the said Contract and the Bond within ten (10) days after being presented with the prescribed Contract forms, the check or Bid Bond accompanying his bid, and the money payable thereon, shall be paid into the funds of the City of Hollywood, Florida, otherwise, the check or Bid Bond accompanying this Proposal shall be returned to the undersigned.

Attached hereto is a certified check on the

\_\_\_\_\_ Bank of \_\_\_\_\_

or approved Bid Bond for the sum of

Fourty Six Thousand Eight Hundred Ten Dollars and Fifty Cents Dollars (\$46,810.50) according to the conditions under the Instructions to Bidders and provisions therein.

NOTE: If a Bidder is a corporation, the legal name of the corporation shall be set forth below, together with signature(s) of the officer or officers authorized to sign Contracts on behalf of the corporation and corporate seal; if Bidder is a partnership, the true name of the firm shall be set forth below with the signature(s) of the partner or partners authorized to sign Contracts in behalf of the partnership; and if the Bidder is an individual, his signature shall be placed below; if a partnership, the names of the general partners.

WHEN THE BIDDER IS AN INDIVIDUAL:

\_\_\_\_\_  
(Signature of Individual)

\_\_\_\_\_  
(Printed Name of Individual)

\_\_\_\_\_  
(Address)

\*\*\*\*\*

WHEN THE BIDDER IS A SOLE PROPRIETORSHIP OR OPERATES UNDER A TRADE NAME:

\_\_\_\_\_  
(Name of Firm)

\_\_\_\_\_  
(Address)

\_\_\_\_\_  
(Signature of Individual) (SEAL)



\*\*\*\*\*

WHEN THE BIDDER IS A PARTNERSHIP:

\_\_\_\_\_  
(Name of Firm) A Partnership

\_\_\_\_\_  
(Address)

By: \_\_\_\_\_  
(SEAL)  
(Partner)

Name and Address of all Partners:

\_\_\_\_\_  
\_\_\_\_\_

\*\*\*\*\*

WHEN THE BIDDER IS A JOINT VENTURE:

\_\_\_\_\_  
(Correct Name of Corporation)

By: \_\_\_\_\_ (SEAL)  
(Address)

\_\_\_\_\_  
(Official Title)

As Joint Venture  
(Corporate Seal)

Organized under the laws of the State of \_\_\_\_\_, and authorized by the law to make this bid and perform all Work and furnish materials and equipment required under the Contract Documents.

\*\*\*\*\*

WHEN THE BIDDER IS A CORPORATION:

Razorback LLC  
\_\_\_\_\_  
(Correct Name of Corporation)

By: \_\_\_\_\_  
(SEAL)

MGRM  
\_\_\_\_\_

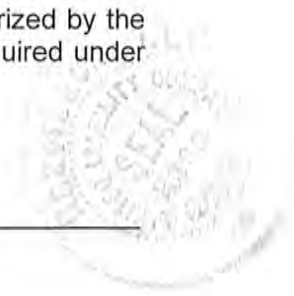

(Official Title)

177 Anclote Road, Tarpon Springs, FL 34689  
(Address of Corporation)

Organized under the laws of the State of Florida, and authorized by the law to make this bid and perform all Work and furnish materials and equipment required under the Contract Documents.

CERTIFIED COPY OF RESOLUTION OF  
BOARD OF DIRECTORS

Razorback LLC  
(Name of Corporation)

RESOLVED that Anthony Houllis  
(Person Authorized to Sign)

MGRM Razorback LLC of  
(Title) (Name of Corporation)

be authorized to sign and submit the Bid or Proposal of this corporation for the following project:

**CLARIFIER NO. 3 REPAIR  
ECSD Project Number: 22-9525  
Bid No. REQ-038-23-JJ**

The foregoing is a true and correct copy of the Resolution adopted by

Razorback LLC at a meeting of its Board of  
(Name of Corporation)

Directors held on the 18th day of September, 2008.

By: 

Title: MGRM

(SEAL)

The above Resolution MUST BE COMPLETED if the Bidder is a Corporation.



- END OF SECTION -

RAZORBACK LLC | NO LIMIT

177 Anclote Road  
Tarpon Springs, FL 34689  
(727) 938-9500  
info@razorbackllc.com  
razorbackllc.com

## Clarifier No. 3 Repair



<b>Proposal Owner</b>	City of Hollywood
<b>IFB Number</b>	038-23-JJ
<b>ITB Name</b>	Clarifier No. 3 Repair
<b>Submission Due Date</b>	February 23, 2023 at 3:00 PM
<b>Submitted Via</b>	OpenGov
<b>Bidder Name</b>	Razorback LLC
<b>Bidder Address</b>	177 Anclote Road, Tarpon Springs, FL 34689
<b>Bidder Telephone Number</b>	(727) 938-9500



177 Anclote Road  
Tarpon Springs, FL 34689  
(727) 938-9500  
info@razorbackllc.com  
razorbackllc.com

**Table of Contents**

**Section I: Scope of Work Qualifications.....1**

**Section II: Forms 1-16.....3**

Form 1: Submittal Checklist.....4

Form 2: Acknowledgement & Signature Page.....5

Form 3: Bid Form.....6

Form 4: Vendor Reference Forms.....8

Form 5: Hold Harmless & Indemnity Clause.....12

Form 6: Non-Collusion Affidavit.....13

Form 7: Sworn Statement Pursuant to Section 287.133 (3) (a)  
FL Statutes on Public Entity Crimes.....14

Form 8: Certifications Regarding Debarment, Suspension & Other  
Responsibility Matters.....16

Form 9: Drug-Free Workplace Program.....17

Form 10: Solicitation, Giving, & Acceptance of Gifts Policy.....18

Form 11: W-9.....19

Form 12: Trench Safety.....20

Form 13: Bid Guaranty Form.....21

Form 14: List of Subcontractors.....27

Form 15: Information Required From Bidders.....28

-Current Contracts.....31

-GC License.....32

-Similar Projects.....33

-Resume.....34

Form 16: Proposal.....35

**Section III: Certificates of Insurance.....39**

**Section IV: Proof of State of Florida Sunbiz Registration.....42**



177 Anclote Road  
Tarpon Springs, FL 34689  
(727) 938-9500  
info@razorbackllc.com  
razorbackllc.com

**Section I: Scope of Work Qualifications**



177 Anclote Road  
Tarpon Springs, FL 34689  
(727) 938-9500  
info@razorbackllc.com  
razorbackllc.com

**Scope of Work Qualifications**

Licensed as a general contractor in Florida since 2008, Razorback LLC has provided high quality, precision, performance, and delivery of services under contract for over 100 construction-related projects throughout the United States. Providing fabrication, installation, protective and high-performance coating systems, surface preparation, and inspection services to industrial, commercial, and government entities on a multitude of surface types such as iron, aluminum, stucco, concrete, masonry, structural steel, etc. Our projects focus on infrastructure restoration, ranging from minor and major repairs to continuous service agreements with projects that have included roads, bridges, and water and wastewater treatment plants.

Comprised of nationally Certified Safety and Quality Control experts, the Razorback Team utilizes the diverse experience of each employee to develop innovative strategies for each project. Our highly trained AWS-certified welders/pipefitters as well as our SSPC and NACE-certified coating applicators have extensive experience on projects such as this one and have developed a reputation as a leader in quality ensuring successful results on time and within budget.



177 Anclote Road  
Tarpon Springs, FL 34689  
(727) 938-9500  
info@razorbackllc.com  
razorbackllc.com

**Section II: Forms 1-16**

- Form 1: Submittal Checklist
- Form 2: Acknowledgement & Signature Page
- Form 3: Bid Form
- Form 4: Vendor Reference Forms
- Form 5: Hold Harmless & Indemnity Clause
- Form 6: Non-Collusion Affidavit
- Form 7: Sworn Statement Pursuant to Section 287.133 (3) (a)  
    FL Statutes on Public Entity Crimes
- Form 8: Certifications Regarding Debarment, Suspension & Other  
    Responsibility Matters
- Form 9: Drug-Free Workplace Program
- Form 10: Solicitation, Giving, & Acceptance of Gifts Policy
- Form 11: W-9
- Form 12: Trench Safety
- Form 13: Bid Guaranty Form
- Form 14: List of Subcontractors
- Form 15: Information Required From Bidders
  - Current Contracts
  - GC License
  - Equipment List
  - Similar Projects
  - Resume
- Form 16: Proposal

# FORM 1

## SUBMITTAL CHECKLIST FORM

The items below are required components of your solicitation response in order for your bid/proposal/submittal to be considered responsive and responsible. Please complete and submit this submittal checklist form as the cover page of your submittal with all of the items below in the order listed.

Please indicate Yes or No in the "Submitted (Yes/No)" column below to indicate which required components were provided with your submittal.

Submitted (Yes/No)	Required Bid Components
Yes	This Submittal Checklist Form completed and included as the cover page of your submittal.
Yes	A Table of Contents that clearly identifies each section and page number of your submittal.
Yes	Information and/or documentation that addresses and/or meets the requirements outlined in Section III – Scope of Work/Services, including any procedural or technical enhancements/innovations which do not materially deviate from the objectives or required content of the Scope of Work/Services.
Yes	Forms (Completed) Form 1 Submittal Checklist Form* Form 2 Acknowledgement and Signature Page Form 3 Bid Form* Form 4 Vendor Reference Form* Form 5 Hold Harmless and Indemnity Clause Form 6 Non-Collusion Affidavit Form 7 Sworn Statement...Public Entity Crimes Form 8 Certifications Regarding Debarment... Form 9 Drug-Free Workplace Program Form 10 Solicitation, Giving, and Acceptance... Form 11 W-9 (Request for Taxpayer Identification) Form 12 Trench Safety Form Form 13 Bid Guaranty Form Form 14 List of Subcontractors
Yes	Certificate(s) of insurance that meet the requirements of Section 2.17
Yes	Proof of State of Florida Sunbiz Registration

This checklist is only a guide, please read the entire solicitation to ensure that your submission includes all required information and documentation.



## FORM 2

### ACKNOWLEDGMENT AND SIGNATURE PAGE

This form must be completed and submitted by the date and the time of bid opening.

Legal Company Name (include d/b/a if applicable): Razorback LLC

If Corporation - Date Incorporated/Organized: 09/18/2008 Federal Tax Identification Number: 26-3447303

State Incorporated/Organized: Florida

Company Operating Address: 177 Anclote Road

City: Tarpon Springs State: FL Zip Code: 34689

Remittance Address (if different from ordering address):

City: \_\_\_\_\_ State: \_\_\_\_\_ Zip Code: \_\_\_\_\_

Company Contact Person: Anthony Houllis Email Address: ANTHONY@RAZORBACKLLC.COM

Phone Number (include area code): (727) 938-9500 Fax Number (include area code): \_\_\_\_\_

Company's Internet Web Address: Razorbackllc.com

IT IS HEREBY CERTIFIED AND AFFIRMED THAT THE BIDDER/PROPOSER CERTIFIES ACCEPTANCE OF THE TERMS, CONDITIONS, SPECIFICATIONS, ATTACHMENTS AND ANY ADDENDA. THE BIDDER/PROPOSER SHALL ACCEPT ANY AWARDS MADE AS A RESULT OF THIS SOLICITATION. BIDDER/PROPOSER FURTHER AGREES THAT PRICES QUOTED WILL REMAIN FIXED FOR THE PERIOD OF TIME STATED IN THE SOLICITATION.

Bidder/Proposer's Authorized Representative's Signature:  Date: 02/08/2023

Type or Print Name: Anthony Houllis

THE EXECUTION OF THIS FORM CONSTITUTES THE UNEQUIVOCAL OFFER OF BIDDER/PROPOSER TO BE BOUND BY THE TERMS OF ITS PROPOSAL. FAILURE TO SIGN THIS SOLICITATION WHERE INDICATED BY AN AUTHORIZED REPRESENTATIVE SHALL RENDER THE BID/PROPOSAL NON-RESPONSIVE. THE CITY MAY, HOWEVER, IN ITS SOLE DISCRETION, ACCEPT ANY BID/PROPOSAL THAT INCLUDES AN EXECUTED DOCUMENT WHICH UNEQUIVOCALLY BINDS THE BIDDER/PROPOSER TO THE TERMS OF ITS OFFER.

# FORM 3

## BID FORM

The City is seeking bids/proposals from qualified vendors for the items listed below in accordance with the terms, conditions, and specifications contained in this solicitation.

Estimated quantities listed are for information and tabulation purposes only. No warranty or guarantee of quantities needed is given or implied. It is understood that the Contractor will furnish the City's needs as they arise.

### BASE BID

Item No.	Position Classifications	Quantity	Unit	Unit Price	Total
1.	Mobilization (shall not exceed 3% of the sum of Bid Items No. 2 and No. 3).	1	Lump Sum	\$ 17,000	\$
2.	<u>Clarifier No. 3 Repair</u> : All work required for the repair of a failed 16-inch diameter 90-degree elbow joint and pipe segment on the return sludge line (ductile iron pipe) located below grade within the 48-inch diameter clarifier feed line at Clarifier No. 3, as required in the Contract Documents.	1	Lump Sum	\$ 390,000	Type text here \$ 390,000
3.	<u>Clarifier No. 3 Reinstallation of Mechanism</u> : All work required for the reinstallation of Clarifier No. 3 mechanism if removed under Bid Item No. 2, including reassembly/installation of existing equipment post-repair, and all work necessary to return clarifier to service.	1	Lump Sum	\$ 178,000	\$ 178,000
4.	Permit Fee Allowance	1	Allowance	\$50,000	\$50,000
5.	Undefined Conditions Allowance	1	Allowance	\$285,000	\$285,000
6.	Consideration for Indemnification	1	\$10	\$10	\$10
7.	Demobilization (shall not exceed 3% of the sum of Bid Items No. 2 and No. 3).	1	Lump Sum	\$ 2,000	\$ 2,000
Miscellaneous Construction					
8.	Field Crew (Superintendent)	40	hr	\$ 75	\$ 3,000
9.	Field Crew (Operator)	40	hr	\$ 60	\$ 2,400
10.	Field Crew (Laborer x 2)	40	hr	\$ 45	\$ 1,800
11.	Equipment, Excavator, 5 CY	40	hr	\$ 75	\$ 3,000
12.	Equipment, Flat Bed Truck, 12'	40	hr	\$ 50	\$ 2,000
13.	Equipment, Loader	40	hr	\$ 50	\$ 2,000
<b>GRAND TOTAL BASE BID PRICE</b>					<b>\$ 936,210</b>
<b>GRAND TOTAL BASE BID PRICE (in words):</b>					
Nine Hundred Thirty Six Thousand Two Hundred Ten					

**ALTERNATE BID ITEMS**

The following items are at the City's option and shall not be included in the Total Base Bid, shall not affect the Contract Award, and shall not affect substantial and final completion time requirements.

Item No.	Position Classifications	Quantity	Unit	Unit Price	Total
A-1.	<u>Furnish and Install Clarifier No. 3 Equipment (Complete Mechanism Replacement, Carbon Steel)</u> : All work for complete replacement of the mechanism at Clarifier No. 3, in the event it is deemed necessary. The material of the replacement mechanism shall be carbon steel components with required surface preparation and coating system per the Contract documents. Work includes but is not limited to furnishing, delivering, installing and testing Clarifier No. 3 drive and associated appurtenances.	1	Lump Sum	\$ 2,580,000	\$ 2,580,000
A-2.	<u>Furnish and Install Clarifier No. 3 Equipment (Complete Mechanism Replacement, 316 Stainless Steel)</u> : All work for complete replacement of the mechanism at Clarifier No. 3, in the event it is deemed necessary. The material of the replacement mechanism shall be 316 stainless steel components per the Contract documents. Work includes but is not limited to furnishing, delivering, installing and testing Clarifier No. 3 drive and associated appurtenances.	1	Lump Sum	\$ 3,616,000	\$ 3,616,000
A-3.	<u>Furnish and Install Clarifier No. 3 Weirs and Scum Baffles</u> : All work for replacement of the fiberglass v-notched weirs and scum baffles at Clarifier No. 3, in the event it is deemed necessary. Item shall include payment for all labor, equipment, and materials for all work necessary and required for the replacement of equipment, as detailed in the Contract Documents, for a complete and operable system.	1	Lump Sum	\$ 647,619	\$ 647,619
A-4.	<u>Furnish and Install Clarifier No. 3 Density Current Baffles</u> : All work for replacement of the density current baffles at Clarifier No. 3, in the event it is deemed necessary. Item shall include payment for all labor, equipment, and materials for all work necessary and required for the replacement of equipment, as detailed in the Contract Documents, for a complete and operable system.	1	Lump Sum	\$ 444,602	\$ 444,602

Razorback LLC

Company Name

  
Authorized Signature

Anthony Houllis

Print Name

MGRM

Title

2/22/2023

Date

# FORM 4

## VENDOR REFERENCE FORM

City of Hollywood Solicitation #: 038-23-JJ  
 Reference for: Razorback LLC

Organization/Firm Name providing reference: City of St. Petersburg  
 Organization/Firm Contact Name: Robert L. Ecklund Title: Construction Inspector  
 Email: Robert.Ecklund@stpete.org Phone: (727) 244-7269  
 Name of Referenced Project: Washington Terrace Tank Nos. 1 & 4 - Water Tanks Painting & Repair FY2018 Contract No: 18112-111  
 Date Services were provided: 09/27/2021- 03/02/2022 Project Amount: \$895,115  
 Referenced Vendor's role in Project:  Prime Vendor  Subcontractor/ Subconsultant  
 Would you use the Vendor again?  Yes  No. Please specify in additional comments

**Description of services provided by Vendor (provide additional sheet if necessary):**  
 Power washing entire exterior surfaces and appurtenances, removed lead based paint on exterior shell, surface preparation on both tanks and appurtenances including overflow box and piping, removed and replaced stainless steel brackets and fasteners, applied caulking to all laps, joints, gaps, and connections, removed & replaced interior ladder including rungs, rails and supports and applied coating system to both tanks.

Please rate your experience with the Vendor	Need Improvement	Satisfactory	Excellent	Not Applicable
<b>Vendor's Quality of Service</b>				
a. Responsive	<input type="checkbox"/>	<input type="checkbox"/>	<input checked="" type="checkbox"/>	<input type="checkbox"/>
b. Accuracy	<input type="checkbox"/>	<input type="checkbox"/>	<input checked="" type="checkbox"/>	<input type="checkbox"/>
c. Deliverables	<input type="checkbox"/>	<input type="checkbox"/>	<input checked="" type="checkbox"/>	<input type="checkbox"/>
<b>Vendor's Organization:</b>				
a. Staff expertise	<input type="checkbox"/>	<input type="checkbox"/>	<input checked="" type="checkbox"/>	<input type="checkbox"/>
b. Professionalism	<input type="checkbox"/>	<input type="checkbox"/>	<input checked="" type="checkbox"/>	<input type="checkbox"/>
c. Staff turnover	<input type="checkbox"/>	<input type="checkbox"/>	<input checked="" type="checkbox"/>	<input type="checkbox"/>
<b>Timeliness/Cost Control of:</b>				
a. Project	<input type="checkbox"/>	<input type="checkbox"/>	<input checked="" type="checkbox"/>	<input type="checkbox"/>
b. Deliverables	<input type="checkbox"/>	<input type="checkbox"/>	<input checked="" type="checkbox"/>	<input type="checkbox"/>

**Additional Comments (provide additional sheet if necessary):**  
 Contractor met or exceeded the contract specifications; all restorations was done promptly, and I would look forward to working with them again.

****THIS SECTION FOR CITY USE ONLY****						
Verified via:	Email:	<input type="checkbox"/>	Verbal:	<input type="checkbox"/>	Mail:	<input type="checkbox"/>
Verified by:	Name:				Title:	
	Department:				Date:	

# FORM 4

## VENDOR REFERENCE FORM

City of Hollywood Solicitation #: 038-23-JJ  
 Reference for: Razorback LLC

Organization/Firm Name providing reference: City of Dunedin  
 Organization/Firm Contact Name: Brian Antonian Title: Plant Superintendent  
 Email: bantonian@dunedinfl.net Phone: (727) 298-3249 X 1620  
 Name of Referenced Project: Rehabbing Belcher/Curlew/Jerry Lake Pump Stations Contract No:  
 Date Services were provided: 05/12/2021- 05/25/2021 Project Amount: \$39,900  
 Referenced Vendor's role in Project:  Prime Vendor  Subcontractor/ Subconsultant  
 Would you use the Vendor again?  Yes  No. Please specify in additional comments

Description of services provided by Vendor (provide additional sheet if necessary):  
 Exterior surface prep and coatings ductile iron pipe located at 3 different locations. Surface prep included pressure washing and degreasing to remove contaminants, power tool and hand tool to remove rusted/bare areas. Also, spot blasting and spot priming.

Please rate your experience with the Vendor	Need Improvement	Satisfactory	Excellent	Not Applicable
<b>Vendor's Quality of Service</b>				
a. Responsive	<input type="checkbox"/>	<input type="checkbox"/>	<input checked="" type="checkbox"/>	<input type="checkbox"/>
b. Accuracy	<input type="checkbox"/>	<input type="checkbox"/>	<input checked="" type="checkbox"/>	<input type="checkbox"/>
c. Deliverables	<input type="checkbox"/>	<input type="checkbox"/>	<input checked="" type="checkbox"/>	<input type="checkbox"/>
<b>Vendor's Organization:</b>				
a. Staff expertise	<input type="checkbox"/>	<input type="checkbox"/>	<input checked="" type="checkbox"/>	<input type="checkbox"/>
b. Professionalism	<input type="checkbox"/>	<input type="checkbox"/>	<input checked="" type="checkbox"/>	<input type="checkbox"/>
c. Staff turnover	<input type="checkbox"/>	<input type="checkbox"/>	<input checked="" type="checkbox"/>	<input type="checkbox"/>
<b>Timeliness/Cost Control of:</b>				
a. Project	<input type="checkbox"/>	<input type="checkbox"/>	<input checked="" type="checkbox"/>	<input type="checkbox"/>
b. Deliverables	<input type="checkbox"/>	<input type="checkbox"/>	<input checked="" type="checkbox"/>	<input type="checkbox"/>

Additional Comments (provide additional sheet if necessary):  
 RAZORBACK DID A FANTASTIC JOB, you will not be disappointed. Excellent work, great workers.  
 Brian Antonian 1/30/2023

\*\*\*\*THIS SECTION FOR CITY USE ONLY\*\*\*\*

Verified via:	Email:	<input type="checkbox"/>	Verbal:	<input type="checkbox"/>	Mail:	<input type="checkbox"/>
Verified by:	Name:		Title:			
	Department:		Date:			

# FORM 4

## VENDOR REFERENCE FORM

City of Hollywood Solicitation #: 038-23-JJ  
 Reference for: Razorback LLC

Organization/Firm Name providing reference: National Park Service  
 Organization/Firm Contact Name: William Vazquez Title: Contracting Officer  
 Email: william\_vazquez@nps.gov Phone: (305) 242-7793  
 Name of Referenced Project: Rehabilitate Everglades Flamingo Wastewater Treatment Plant Contract No: 140P5420C0016  
 Date Services were provided: 09/01/2020- 02/01/2021 Project Amount: \$805,500  
 Referenced Vendor's role in Project:  Prime Vendor  Subcontractor/ Subconsultant  
 Would you use the Vendor again?  Yes  No. Please specify in additional comments

**Description of services provided by Vendor (provide additional sheet if necessary):**  
 Selective demolition, sludge removal, structural steel repairs to the membrane bioreactor & membrane treatment tank, steel piping repairs, concrete form & pour, installing a sluice gate & actuators, replacing valves & flow system, interior & exterior tank surface blast cleaning, newly fabricated aluminum staircase, electrical improvements and coating systems applied.

Please rate your experience with the Vendor	Need Improvement	Satisfactory	Excellent	Not Applicable
<b>Vendor's Quality of Service</b>				
a. Responsive	<input type="checkbox"/>	<input type="checkbox"/>	<input checked="" type="checkbox"/>	<input type="checkbox"/>
b. Accuracy	<input type="checkbox"/>	<input type="checkbox"/>	<input checked="" type="checkbox"/>	<input type="checkbox"/>
c. Deliverables	<input type="checkbox"/>	<input type="checkbox"/>	<input checked="" type="checkbox"/>	<input type="checkbox"/>
<b>Vendor's Organization:</b>				
a. Staff expertise	<input type="checkbox"/>	<input type="checkbox"/>	<input checked="" type="checkbox"/>	<input type="checkbox"/>
b. Professionalism	<input type="checkbox"/>	<input type="checkbox"/>	<input checked="" type="checkbox"/>	<input type="checkbox"/>
c. Staff turnover	<input type="checkbox"/>	<input type="checkbox"/>	<input type="checkbox"/>	<input checked="" type="checkbox"/>
<b>Timeliness/Cost Control of:</b>				
a. Project	<input type="checkbox"/>	<input type="checkbox"/>	<input checked="" type="checkbox"/>	<input type="checkbox"/>
b. Deliverables	<input type="checkbox"/>	<input type="checkbox"/>	<input checked="" type="checkbox"/>	<input type="checkbox"/>

**Additional Comments (provide additional sheet if necessary):**  
 The contractor was very responsive and worked efficiently and diligently until project completion. I would recommend this contractor for future projects.

****THIS SECTION FOR CITY USE ONLY****						
Verified via:	Email:	<input type="checkbox"/>	Verbal:	<input type="checkbox"/>	Mail:	<input type="checkbox"/>
Verified by:	Name:				Title:	
	Department:				Date:	

# FORM 4

## VENDOR REFERENCE FORM

City of Hollywood Solicitation #: 038-23-JJ  
 Reference for: Razorback LLC

Organization/Firm Name providing reference: City of West Palm Beach  
 Organization/Firm Contact Name: Sandra Feliciano Title: WTP Operations Coordinator  
 Email: SFeliciano@wpb.org Phone: (561) 718-7900  
 Name of Referenced Project: Master Water Storage Tank Cleaning and Repair Services Contract No: 18-19-115  
 Date Services were provided: 05/28/2019- Ongoing (Term) Project Amount: \$501,445.16  
 Referenced Vendor's role in Project:  Prime Vendor  Subcontractor/ Subconsultant  
 Would you use the Vendor again?  Yes  No. Please specify in additional comments

**Description of services provided by Vendor (provide additional sheet if necessary):**  
 Cleaning, surface prep and coating services to multiple storage tanks. Work included pressure washing both steel and concrete tanks, disinfecting, baffle curtain repairs, cables replaced, Dome telemetry repairs, Dome void repairs, spalling repairs, interior surface repairs and replacements, interior piping sandblasting, and coating.

Please rate your experience with the Vendor	Need Improvement	Satisfactory	Excellent	Not Applicable
<b>Vendor's Quality of Service</b>				
a. Responsive	<input type="checkbox"/>	<input checked="" type="checkbox"/>	<input type="checkbox"/>	<input type="checkbox"/>
b. Accuracy	<input type="checkbox"/>	<input checked="" type="checkbox"/>	<input type="checkbox"/>	<input type="checkbox"/>
c. Deliverables	<input type="checkbox"/>	<input checked="" type="checkbox"/>	<input type="checkbox"/>	<input type="checkbox"/>
<b>Vendor's Organization:</b>				
a. Staff expertise	<input type="checkbox"/>	<input type="checkbox"/>	<input checked="" type="checkbox"/>	<input type="checkbox"/>
b. Professionalism	<input type="checkbox"/>	<input type="checkbox"/>	<input checked="" type="checkbox"/>	<input type="checkbox"/>
c. Staff turnover	<input type="checkbox"/>	<input type="checkbox"/>	<input type="checkbox"/>	<input checked="" type="checkbox"/>
<b>Timeliness/Cost Control of:</b>				
a. Project	<input type="checkbox"/>	<input type="checkbox"/>	<input checked="" type="checkbox"/>	<input type="checkbox"/>
b. Deliverables	<input type="checkbox"/>	<input type="checkbox"/>	<input checked="" type="checkbox"/>	<input type="checkbox"/>

**Additional Comments (provide additional sheet if necessary):**  
*Sandra Feliciano 2/3/2023*  
*City of West Palm Beach, WTP Operations Coordinator*

****THIS SECTION FOR CITY USE ONLY****						
Verified via:	Email:	<input type="checkbox"/>	Verbal:	<input type="checkbox"/>	Mail:	<input type="checkbox"/>
Verified by:	Name:				Title:	
	Department:				Date:	

# FORM 5

## HOLD HARMLESS AND INDEMNITY CLAUSE

Razorback LLC

---

**(Company Name and Authorized Signature, Print Name)**

, the contractor, shall indemnify, defend and hold harmless the City of Hollywood, its elected and appointed officials, employees and agents for any and all suits, actions, legal or administrative proceedings, claims, damage, liabilities, interest, attorney's fees, costs of any kind whether arising prior to the start of activities or following the completion or acceptance and in any manner directly or indirectly caused, occasioned or contributed to in whole or in part by reason of any act, error or omission, fault or negligence whether active or passive by the contractor, or anyone acting under its direction, control, or on its behalf in connection with or incident to its performance of the contract.



Signature

Anthony Houllis

---

Printed Name

Razorback LLC

---

Name of Company

MGRM

---

Title



**FORM 6**

**NON-COLLUSION AFFIDAVIT**

**STATE OF:** Florida

**COUNTY OF:** Pinellas, being first duly sworn, deposes and says that:

- (1) He/she is MGRM of Razorback LLC, the Proposer that has submitted the attached Proposal.
- (2) He/she has been fully informed regarding the preparation and contents of the attached Proposal and of all pertinent circumstances regarding such Proposal;
- (3) Such Proposal is genuine and is not a collusion or sham Proposal;
- (4) Neither the said Proposer nor any of its officers, partners, owners, agents, representatives, employees or parties in interest, including this affiant has in any way colluded, conspired, connived or agreed, directly or indirectly with any other Proposer, firm or person to submit a collusive or sham Proposal in connection with the contractor for which the attached Proposal has been submitted or to refrain from bidding in connection with such contract, or has in any manner, directly or indirectly, sought by agreement or collusion or communication or conference with any other Proposer, firm or person to fix the price or prices, profit or cost element of the Proposal price or the Proposal price of any other Proposer, or to secure an advantage against the City of Hollywood or any person interested in the proposed Contract; and
- (5) The price or prices quoted in the attached Proposal are fair and proper and are not tainted by any collusion, conspiracy, connivance or unlawful agreement on the part of the Proposer or any of its agents, representatives, owners, employees, or parties in interest, including this affiant.

  
\_\_\_\_\_  
Signature

Anthony Houllis  
\_\_\_\_\_  
Printed Name

Razorback LLC  
\_\_\_\_\_  
Name of Company

MGRM  
\_\_\_\_\_  
Title

## FORM 7

### SWORN STATEMENT PURSUANT TO SECTION 287.133 (3) (a) FLORIDA STATUTES ON PUBLIC ENTITY CRIMES

THIS FORM MUST BE SIGNED AND SWORN TO IN THE PRESENCE OF A NOTARY  
PUBLIC OR OTHER OFFICIAL AUTHORIZED TO ADMINISTER OATHS

1. This form statement is submitted to the City of Hollywood by  
Anthony Houllis, MGRM for Razorback LLC  
(Print individual's name and title) (Print name of entity submitting sworn statement)  
whose business address is  
177 Anclote Road, Tarpon Springs, FL 34689  
and if applicable its Federal Employer Identification Number (FEIN) is 26-3447303. If the  
entity has no FEIN, include the Social Security Number of the individual signing this sworn  
statement.
- 

2. I understand that "public entity crime," as defined in paragraph 287.133(1)(g), Florida Statutes, means a violation of any state or federal law by a person with respect to and directly related to the transaction of business with any public entity or with an agency or political subdivision of any other state or with the United States, including, but not limited to, any bid, proposal, reply, or contract for goods or services, any lease for real property, or any contract for the construction or repair of a public building or public work, involving antitrust, fraud, theft, bribery, collusion, racketeering, conspiracy, or material misinterpretation.
3. I understand that "convicted" or "conviction" as defined in Paragraph 287.133(1)(b), Florida Statutes, means a finding of guilt or a conviction of a public entity crime, with or without an adjudication of guilt, in an federal or state trial court of record relating to charges brought by indictment or information after July 1, 1989, as a result of a jury verdict, nonjury trial, or entry of a plea of guilty or nolo contendere.
4. I understand that "Affiliate," as defined in paragraph 287.133(1)(a), Florida Statutes, means:
1. A predecessor or successor of a person convicted of a public entity crime, or
  2. An entity under the control of any natural person who is active in the management of the entity and who has been convicted of a public entity crime. The term "affiliate" includes those officers, directors, executives, partners, shareholders, employees, members, and agents who are active in the management of an affiliate. The ownership by one person of shares constituting a controlling interest in another person, or a pooling of equipment or income among persons when not for fair market value under an arm's length agreement, shall be a prima facie case that one person controls another person. A person who knowingly enters into a joint venture with a person who has been convicted of a public entity crime in Florida during the preceding 36 months shall be considered an affiliate.

- 5 I understand that "person," as defined in Paragraph 287.133(1)(e), Florida Statutes, means any natural person or any entity organized under the laws of any state or of the

United States with the legal power to enter into a binding contract and which bids or applies to bid on contracts let by a public entity, or which otherwise transacts or applies to transact business with a public entity. The term "person" includes those officers, executives, partners, shareholders, employees, members, and agents who are active in management of an entity.

6. Based on information and belief, the statement which I have marked below is true in relation to the entity submitting this sworn statement. (Please indicate which statement applies.)

Neither the entity submitting sworn statement, nor any of its officers, director, executives, partners, shareholders, employees, members, or agents who are active in the management of the entity, nor any affiliate of the entity has been charged with and convicted of a public entity crime subsequent to July 1, 1989.

\_\_\_\_\_ The entity submitting this sworn statement, or one or more of its officers, directors, executives, partners, shareholders, employees, members, or agents who are active in the management of the entity, or an affiliate of the entity, or an affiliate of the entity has been charged with and convicted of a public entity crime subsequent to July 1, 1989.

\_\_\_\_\_ The entity submitting this sworn statement, or one or more of its officers, directors, executives, partners, shareholders, employees, members, or agents who are active in the management of the entity, or an affiliate of the entity has been charged with and convicted of a public entity crime, but the Final Order entered by the Hearing Officer in a subsequent proceeding before a Hearing Officer of the State of the State of Florida,

Division of Administrative Hearings, determined that it was not in the public interest to place the entity submitting this sworn statement on the convicted vendor list. (attach a copy of the Final Order).

I UNDERSTAND THAT THE SUBMISSION OF THIS FORM TO THE CONTRACTING OFFICER FOR THE PUBLIC ENTITY IDENTIFIED IN PARAGRAPH 1 (ONE) ABOVE IS FOR THAT PUBLIC ENTITY ONLY AND THAT THIS FORM IS VALID THROUGH DECEMBER 31 OF THE CALENDAR YEAR IN WHICH IT IS FILED. I ALSO UNDERSTAND THAT I AM REQUIRED TO INFORM THAT PUBLIC ENTITY PRIOR TO ENTERING INTO A CONTRACT IN EXCESS OF THE THRESHOLD AMOUNT PROVIDED IN SECTION 287.017 FLORIDA STATUTES FOR A CATEGORY TWO OF ANY CHANGE IN THE INFORMATION CONTAINED IN THIS FORM.

  
\_\_\_\_\_  
(Signature)

Sworn to and subscribed before me this 8th day of February, 2023.

Personally known Anthony Houllis

Or produced identification \_\_\_\_\_ Notary Public-State of Florida

\_\_\_\_\_  
(Type of identification) my commission expires \_\_\_\_\_



Heather B. Stamas  
Comm. # GG353617  
Expires: July 10, 2023  
Bonded Thru Aaron Notary  
Heather B. Stamas  
\_\_\_\_\_  
Printed, typed or stamped commissioned name of notary public

**FORM 8**

**CERTIFICATIONS REGARDING DEBARMENT, SUSPENSION AND OTHER RESPONSIBILITY MATTERS**

The applicant certifies that it and its principals:

- (a) Are not presently debarred, suspended, proposed for debarment, declared ineligible, sentenced to a denial of Federal benefits by a State or Federal court, or voluntarily excluded from covered transactions by any Federal department or agency;
- (b) Have not within a three-year period preceding this application been convicted of or had a civil judgment rendered against them for commission of fraud or a criminal offense in connection with obtaining, attempting to obtain, or performing a public (Federal, State, or local) transaction or contract under a public transaction, violation of Federal or State antitrust statutes or commission of embezzlement, theft, forgery, bribery, falsification or destruction of records, making false statements, or receiving stolen property;
- (c) Are not presently indicted for or otherwise criminally or civilly charged by a governmental entity (Federal, State, or local) with commission of any of the offenses enumerated in paragraph (b) of this certification; and
- (d) Have not within a three-year period preceding this application had one or more public transactions (Federal, State, or local) terminated for cause or default.

Applicant Name and Address:

Razorback LLC

177 Anclote Road

Tarpon Springs, FL 34689

Application Number and/or Project Name:

Project # 038-23-JJ

Applicant IRS/Vendor Number: 26-3447303



Signature

Anthony Houllis

Printed Name

Razorback LLC

Name of Company

MGRM

Title

## FORM 9

### DRUG-FREE WORKPLACE PROGRAM

IDENTICAL TIE PROPOSALS - Preference shall be given to businesses with drug-free workplace programs. Whenever two or more bids which are equal with respect to price, quality, and service are received by the State or by any political subdivision for the procurement of commodities or contractual services, a bid received from a business that certifies that it has implemented a drug-free workplace program shall be given preference in the award process. Established procedures for processing tie proposals will be followed if none of the tied vendors have a drug-free workplace program. In order to have a drug-free workplace program, a business shall:

1. Publish a statement notifying employees that the unlawful manufacture, distribution, dispensing, possession, or use of a controlled substance is prohibited in the workplace and specifying the actions that will be taken against employees for violations of such prohibition.
2. Inform employees about the dangers of drug abuse in the workplace, the business's policy of maintaining a drug-free workplace, any available drug counseling, rehabilitation, and employee assistance programs, and the penalties that may be imposed upon employees for drug abuse violations.
3. Give each employee engaged in providing the commodities or contractual services that are under bid a copy of the statement specified in subsection (1).
4. In the statement specified in subsection (1), notify the employee that, as a condition of working on the commodities or contractual services that are under bid, the employee will abide by the terms of the statement and will notify the employer of any conviction of, or plea of guilty or nolo contendere to, any violation of chapter 893 or of any controlled substance law of the United States or any state, for a violation occurring in the workplace no later than five (5) days after such conviction.
5. Impose a sanction on, or require the satisfactory participation in a drug abuse assistance or rehabilitation program (if such is available in the employee's community) by, any employee who is so convicted.
6. Make a good faith effort to continue to maintain a drug-free workplace through implementation of these requirements.

As the person authorized to sign the statement, I certify that this firm complies fully with the above requirements.



Signature

Anthony Houllis

Printed Name

Razorback LLC

Name of Company

MGRM

Title

## FORM 10

### SOLICITATION, GIVING, AND ACCEPTANCE OF GIFTS POLICY

Florida Statute 112.313 prohibits the solicitation or acceptance of Gifts. "No Public officer, employee of an agency, local government attorney, or candidate for nomination or election shall solicit or accept anything of value to the recipient, including a gift, loan, reward, promise of future employment, favor, or service, based upon any understanding that the vote, official action, or judgment of the public officer, employee, local government attorney, or candidate would be influenced thereby." The term "public officer" includes "any person elected or appointed to hold office in any agency, including any person serving on an advisory body."

The City of Hollywood/Hollywood CRA policy prohibits all public officers, elected or appointed, all employees, and their families from accepting any gifts of any value, either directly or indirectly, from any contractor, vendor, consultant, or business with whom the City/CRA does business.

The State of Florida definition of "gifts" includes the following:

- Real property or its use,
- Tangible or intangible personal property, or its use,
- A preferential rate or terms on a debt, loan, goods, or services,
- Forgiveness of indebtedness,
- Transportation, lodging, or parking,
- Food or beverage,
- Membership dues,
- Entrance fees, admission fees, or tickets to events, performances, or facilities,
- Plants, flowers or floral arrangements
- Services provided by persons pursuant to a professional license or certificate.
- Other personal services for which a fee is normally charged by the person providing the services.
- Any other similar service or thing having an attributable value not already provided for in this section.

Any contractor, vendor, consultant, or business found to have given a gift to a public officer or employee, or his/her family, will be subject to dismissal or revocation of contract.

As the person authorized to sign the statement, I certify that this firm will comply fully with this policy.



Signature

Anthony Houllis

Printed Name

Razorback LLC

Name of Company

MGRM

Title

# Request for Taxpayer Identification Number and Certification

**Give Form to the  
 requester. Do not  
 send to the IRS.**

▶ Go to [www.irs.gov/FormW9](http://www.irs.gov/FormW9) for instructions and the latest information.

Print or type.  
 See Specific Instructions on page 3.

**1** Name (as shown on your income tax return). Name is required on this line; do not leave this line blank.  
**RAZORBACK LLC**

**2** Business name/disregarded entity name, if different from above

**3** Check appropriate box for federal tax classification of the person whose name is entered on line 1. Check only **one** of the following seven boxes.

Individual/sole proprietor or single-member LLC     C Corporation     S Corporation     Partnership     Trust/estate

Limited liability company. Enter the tax classification (C=C corporation, S=S corporation, P=Partnership) ▶ S

**Note:** Check the appropriate box in the line above for the tax classification of the single-member owner. Do not check LLC if the LLC is classified as a single-member LLC that is disregarded from the owner unless the owner of the LLC is another LLC that is **not** disregarded from the owner for U.S. federal tax purposes. Otherwise, a single-member LLC that is disregarded from the owner should check the appropriate box for the tax classification of its owner.

Other (see instructions) ▶

**4** Exemptions (codes apply only to certain entities, not individuals; see instructions on page 3):  
 Exempt payee code (if any) \_\_\_\_\_  
 Exemption from FATCA reporting code (if any) \_\_\_\_\_  
*(Applies to accounts maintained outside the U.S.)*

**5** Address (number, street, and apt. or suite no.) See instructions.  
**177 ANCLOTE ROAD**

**6** City, state, and ZIP code  
**TARPON SPRINGS, FL 34689**

**7** List account number(s) here (optional)

Requester's name and address (optional)

## Part I Taxpayer Identification Number (TIN)

Enter your TIN in the appropriate box. The TIN provided must match the name given on line 1 to avoid backup withholding. For individuals, this is generally your social security number (SSN). However, for a resident alien, sole proprietor, or disregarded entity, see the instructions for Part I, later. For other entities, it is your employer identification number (EIN). If you do not have a number, see *How to get a TIN*, later.

**Social security number**

				-			-				
--	--	--	--	---	--	--	---	--	--	--	--

or

**Employer identification number**

2	6	-	3	4	4	7	3	0	3
---	---	---	---	---	---	---	---	---	---

**Note:** If the account is in more than one name, see the instructions for line 1. Also see *What Name and Number To Give the Requester* for guidelines on whose number to enter.

## Part II Certification

Under penalties of perjury, I certify that:

- The number shown on this form is my correct taxpayer identification number (or I am waiting for a number to be issued to me); and
- I am not subject to backup withholding because: (a) I am exempt from backup withholding, or (b) I have not been notified by the Internal Revenue Service (IRS) that I am subject to backup withholding as a result of a failure to report all interest or dividends, or (c) the IRS has notified me that I am no longer subject to backup withholding; and
- I am a U.S. citizen or other U.S. person (defined below); and
- The FATCA code(s) entered on this form (if any) indicating that I am exempt from FATCA reporting is correct.

**Certification instructions.** You must cross out item 2 above if you have been notified by the IRS that you are currently subject to backup withholding because you have failed to report all interest and dividends on your tax return. For real estate transactions, item 2 does not apply. For mortgage interest paid, acquisition or abandonment of secured property, cancellation of debt, contributions to an individual retirement arrangement (IRA), and generally, payments other than interest and dividends, you are not required to sign the certification, but you must provide your correct TIN. See the instructions for Part II, later.

**Sign Here**    Signature of U.S. person ▶    Date ▶ 2-10-21

## General Instructions

Section references are to the Internal Revenue Code unless otherwise noted.

**Future developments.** For the latest information about developments related to Form W-9 and its instructions, such as legislation enacted after they were published, go to [www.irs.gov/FormW9](http://www.irs.gov/FormW9).

### Purpose of Form

An individual or entity (Form W-9 requester) who is required to file an information return with the IRS must obtain your correct taxpayer identification number (TIN) which may be your social security number (SSN), individual taxpayer identification number (ITIN), adoption taxpayer identification number (ATIN), or employer identification number (EIN), to report on an information return the amount paid to you, or other amount reportable on an information return. Examples of information returns include, but are not limited to, the following.

- Form 1099-INT (interest earned or paid)

- Form 1099-DIV (dividends, including those from stocks or mutual funds)
- Form 1099-MISC (various types of income, prizes, awards, or gross proceeds)
- Form 1099-B (stock or mutual fund sales and certain other transactions by brokers)
- Form 1099-S (proceeds from real estate transactions)
- Form 1099-K (merchant card and third party network transactions)
- Form 1098 (home mortgage interest), 1098-E (student loan interest), 1098-T (tuition)
- Form 1099-C (canceled debt)
- Form 1099-A (acquisition or abandonment of secured property)

Use Form W-9 only if you are a U.S. person (including a resident alien), to provide your correct TIN.

*If you do not return Form W-9 to the requester with a TIN, you might be subject to backup withholding. See What is backup withholding, later.*

# FORM 12

## TRENCH SAFETY

This form must be completed and signed by the Respondent.

Failure to complete this form may result in the solicitation being declared non-responsive.

Respondent acknowledges that the Florida Trench Safety Act, Section 553.60 et. seq., which became effective October 1, 1990, shall be in effect during the period of construction of the project. The respondent by signing and submitting the solicitation is, in writing, assuring that it will perform any trench excavation in accordance with applicable trench safety standards. The respondent further identifies the following separate item of cost of compliance with the applicable trench safety standards as well as the method of compliance:

Method of Compliance

Cost  
\$0

Total \$ 0

Respondent acknowledges that this cost is included in the applicable items of their submittal and in the Grand Total Solicitation Price. Failure to complete the above will result in the solicitation being declared non-responsive.

The Respondent is, and the Owner and Engineer are not, responsible to review or assess Respondent's safety precautions, programs or costs, or the means, methods, techniques or technique adequacy, reasonableness of cost, sequences or procedures of any safety precaution, program or cost, including but not limited to, compliance with any and all requirements of Florida Statute Section 553.60 et. seq. cited as the "Trench Safety Act." Respondent is, and the owner and Engineer are not, responsible to determine if any safety related standards apply to the project, including but not limited to, the "Trench Safety Act."

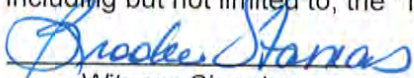
  
Witness Signature

Brooke Stamas  
Witness Printed Name

177 Anclote Road, Tarpon Springs, FL 34689  
Witness Address

02/08/2023  
Date

  
Contractor's Signature

Anthony Houllis  
Printed Name

MGRM  
Title

02/08/2023  
Date

- END OF SECTION -



**Form 13**

**Bid Guaranty Form**

(Construction)

STATE OF FLORIDA

KNOW ALL MEN BY THESE PRESENTS:

That we Razorback, LLC, as Principal, and The Gray Insurance Company as

Surety, are held and firmly bound unto the City of Hollywood in the sum of Forty Six Thousand Eight Hundred Ten and Fifty cents Dollars (\$ 46,810.50) lawful money

of the United States, amounting to 5% of the total SOLICITATION Price, for the payment of said sum, we bind ourselves, our heirs, executors, administrators, and successors, jointly and severally, firmly by these presents.

THE CONDITION OF THIS OBLIGATION IS SUCH, that whereas the principal has submitted the accompanying SOLICITATION, dated \_\_\_\_\_ February 23, 20<sup>23</sup> for

**CLARIFIER NO. 3 REPAIR**

**Bid No. REQ-038-23-JJ**

NOW, THEREFORE, if the principal shall not withdraw said SOLICITATION within 90 days after date of the same and shall within ten days after the prescribed forms are presented to him for signature, enter into a written contract with the CITY, in accordance with the SOLICITATION as accepted, and give bond with good and sufficient surety or sureties, and provide the necessary Insurance Certificates as may be required for the faithful performance and proper fulfillment of such Contract, then this obligation shall be null and void.

Approved SOLICITATION Bond

In the event of the withdrawal of said SOLICITATION within the specified period, or the failure to enter into such contract and give such bond and insurance within the specified time, the principal and the surety shall pay to the City of Hollywood the difference between the amount specified in said SOLICITATION and such larger amount for which the City of Hollywood may in good faith contract with another party to perform the work and/or supply the materials covered by said SOLICITATION.

IN WITNESS WHEREOF, the above bound parties have executed this statement under their several seals this   23rd   day of   February  , 20  ; the name and corporate seal of each corporate party being hereto affixed and these presents duly signed by its undersigned representative, pursuant to authority of its governing body.   \*23

WHEN THE PRINCIPAL IS AN INDIVIDUAL:

Signed, sealed and delivered in the presence of:

  N/A    
Witness

  N/A    
Signature of Individual

  N/A    
Address

  N/A  

  N/A    
Printed Name of Individual

  N/A    
Witness

  N/A    
Address

  N/A

WHEN THE PRINCIPAL IS A CORPORATION:

Attest:

Brooks Starnas  
Secretary **WITNESS**

Razorback, LLC  
Name of Corporation

177 Anclote Road  
Business Address

Tarpon Springs, FL 34689

By: AKH  
(Affix Corporate Seal)

ANTHONY HOULLIS  
Printed Name

MGRM  
Official Title



CERTIFICATE AS TO CORPORATE PRINCIPAL

I, AKH, <sup>MGRM</sup>certify that I am the ~~secretary~~ of the **LLC - Corporation** named as Principal in the attached bond; that ANTHONY HOULLIS who signed the said bond on behalf of the Principal, was then MGRM of said Corporation; that I know his signature, and his signature thereto is genuine and that said bond was duly signed, sealed and attested for and on behalf of said Corporation by authority of its governing body.

AKH (SEAL)  
Secretary **MGRM**

Approved SOLICITATION Bond

TO BE EXECUTED BY CORPORATE SURETY:

Attest:

Susan L Reich  
Secretary Susan L. Reich

The Gray Insurance Company  
Corporate Surety  
PO Box 6202  
Business Address  
Metairie, LA 70009-6202

BY: Gloria A Richards  
(Affix Corporate Seal) Gloria A. Richards  
Attorney-In-Fact &  
FL Lic. Resident Agent

Gloria A. Richards, Attorney-In-Fact & FL Lic. Resident Agent  
Attorney-in-Fact  
Florida Surety Bonds, Inc.

Name of Local Agency

620 N. Wymore Rd., Suite 200, Maitland, FL 32751  
Business Address  
407-786-7770

STATE OF FLORIDA

Before me, a Notary Public, duly commissioned, qualified and acting, personally appeared,  
Gloria A. Richards to me well known, who being by me first duly sworn upon  
oath says that he\*is the attorney-in-fact for the The Gray Insurance Company and  
that the has been authorized by The Gray Insurance Company to execute the forgoing  
bond on behalf of the CONTRACTOR named therein in favor of the City of Hollywood, Florida.  
Subscribed and sworn to before me this 23rd day of February 2023

Elizabeth Luu Karoly Notary Public, State of Florida

My Commission Expires: 07/09/2026

- END OF SECTION-

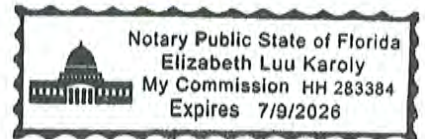

\*/she

**THE GRAY INSURANCE COMPANY  
THE GRAY CASUALTY & SURETY COMPANY**

**GENERAL POWER OF ATTORNEY**

**Bond Number:** N/A                      **Principal:** Razorback, LLC  
**Project:** Bid No. REQ-038-23-JJ; Clarifier No. 3 Repair, City of Hollywood, FL

KNOW ALL BY THESE PRESENTS, THAT The Gray Insurance Company and The Gray Casualty & Surety Company, corporations duly organized and existing under the laws of Louisiana, and having their principal offices in Metairie, Louisiana, do hereby make, constitute, and appoint: **Susan L. Reich, Jeffrey W. Reich, Kim E. Niv, Teresa L. Durham, Cheryl A. Foley, Gloria A. Richards, Robert P. O'Linn, Sarah K. O'Linn, Lisa A. Roseland, and Emily J. Golecki of Maitland, Florida jointly and severally** on behalf of each of the Companies named above its true and lawful Attorney(s)-in-Fact, to make, execute, seal and deliver, for and on its behalf and as its deed, bonds, or other writings obligatory in the nature of a bond, as surety, contracts of suretyship as are or may be required or permitted by law, regulation, contract or otherwise, provided that no bond or undertaking or contract of suretyship executed under this authority shall exceed the amount of \$25,000,000.00.

This Power of Attorney is granted and is signed by facsimile under and by the authority of the following Resolutions adopted by the Boards of Directors of both The Gray Insurance Company and The Gray Casualty & Surety Company at meetings duly called and held on the 26<sup>th</sup> day of June, 2003.

“RESOLVED, that the President, Executive Vice President, any Vice President, or the Secretary be and each or any of them hereby is authorized to execute a power of Attorney qualifying the attorney named in the given Power of Attorney to execute on behalf of the Company bonds, undertakings, and all contracts of surety, and that each or any of them is hereby authorized to attest to the execution of such Power of Attorney, and to attach the seal of the Company; and it is

FURTHER RESOLVED, that the signature of such officers and the seal of the Company may be affixed to any such Power of Attorney or to any certificate relating thereto by facsimile, and any such Power of Attorney or certificate bearing such facsimile signature or facsimile seal shall be binding upon the Company now and in the future when so affixed with regard to any bond, undertaking or contract of surety to which it is attached.

IN WITNESS WHEREOF, The Gray Insurance Company and The Gray Casualty & Surety Company have caused their official seals to be hereinto affixed, and these presents to be signed by their authorized officers this 4<sup>th</sup> day of November, 2022.



By:

*Michael T. Gray*

Michael T. Gray  
President  
The Gray Insurance Company

*Cullen S. Piske*

Cullen S. Piske  
President  
The Gray Casualty & Surety Company



State of Louisiana  
ss:

Parish of Jefferson  
On this 4<sup>th</sup> day of November, 2022, before me, a Notary Public, personally appeared Michael T. Gray, President of The Gray Insurance Company, and Cullen S. Piske, President of The Gray Casualty & Surety Company, personally known to me, being duly sworn, acknowledged that they signed the above Power of Attorney and affixed the seals of the companies as officers of, and acknowledged said instrument to be the voluntary act and deed, of their companies.



Leigh Anne Henican  
Notary Public  
Notary ID No. 92653  
Orleans Parish, Louisiana

*Leigh Anne Henican*

Leigh Anne Henican  
Notary Public, Parish of Orleans State of Louisiana  
My Commission is for Life

I, Mark S. Manguno, Secretary of The Gray Insurance Company, do hereby certify that the above and forgoing is a true and correct copy of a Power of Attorney given by the companies, which is still in full force and effect. IN WITNESS WHEREOF, I have set my hand and affixed the seals of the Company this 23<sup>rd</sup> day of February, 2023.

*Mark S. Manguno*

I, Leigh Anne Henican, Secretary of The Gray Casualty & Surety Company, do hereby certify that the above and forgoing is a true and correct copy of a Power of Attorney given by the companies, which is still in full force and effect. IN WITNESS WHEREOF, I have set my hand and affixed the seals of the Company this 23<sup>rd</sup> day of February, 2023.

*Leigh Anne Henican*



## Form 14

### LIST OF SUBCONTRACTORS

The Respondent shall list below the name and address of each Subcontractor who will perform work under this Contract, and shall also list the portion of the work which will be done by such Subcontractor. After the opening of Submittals, changes or substitutions will be allowed with written approval of the City of Hollywood. Subcontractors must be properly licensed.

	<b>Work to be Performed</b>	<b>Subcontractor's Name / Address</b>
1.	None Anticipated _____ _____	_____ _____
2.	_____ _____	_____ _____
3.	_____ _____	_____ _____
4.	_____ _____	_____ _____
5.	_____ _____	_____ _____
6.	_____ _____	_____ _____
7.	_____ _____	_____ _____
8.	_____ _____	_____ _____
9.	_____ _____	_____ _____
10.	_____ _____	_____ _____

NOTE: Attach additional sheets if required.

- END OF SECTION -

FORM 15

INFORMATION REQUIRED FROM BIDDERS

GENERAL INFORMATION

The Bidder shall furnish the following information. Failure to comply with this requirement may cause its rejection. Additional sheets shall be attached as required.

1. Contractor's Name/Address: Razorback LLC  
177 Anclote Road, Tarpon Springs, FL 34689  
\_\_\_\_\_
  
2. Contractor's Telephone Number: (727) 938-9500  
and e-mail address: ANTHONY@RAZORBACKLLC.COM
  
3. Contractor's License (attach copy): CGC1526612  
Primary Classification: Certified General Contractor  
Broward County License Number (attach copy): \_\_\_\_\_
  
4. Number of years as a Contractor in construction work of the type involved in this Contract: 14+ years  
\_\_\_\_\_
  
5. List the names and titles of all officers of Contractor's firm:  
Anthony Houllis, MGRM  
\_\_\_\_\_  
\_\_\_\_\_  
\_\_\_\_\_
  
6. Name of person who inspected site or proposed work for your firm:  
Name: Trivon McDade  
Date of Inspection: 02/01/2023
  
7. What is the last project of this nature you have completed?  
Rehabilitate Everglades Flamingo Wastewater Treatment Plant  
\_\_\_\_\_

8. Have you ever failed to complete work awarded to you; if so, where and why?

No

9. Name three individuals or corporations for which you have performed work and to which you refer:

Royal Bridge Inc.

US Water Services Corp.

Jacksonville Aviation Authority

10. List the following information concerning all contracts on hand as of the date of submission of this proposal (in case of co-venture, list the information for all coventures).

Name of Project	City	Total Contract Value	Contracted Date of Completion	% Completion to Date
Master Water Treatment Plant	City of West Palm Beach	\$501,445.16	05/27/2024	Term - 80%
Utilities Painting Maintenance Continuing Services	Town of Jupiter	\$1,459,308	11/02/2023	Term - 90%
Re-painting of Aerial Crossings	Charlotte County	\$361,167.70	09/30/2023	Term - 80%
As Needed Utilities General Maintenance Services	Pasco County	\$97,045	11/18/2025	Term - 10%

(Continue list on inset sheet, if necessary) \*\*See attached

11. What equipment do you own that is available for the work?

\*\*\*See attached equipment list

12. What equipment will you purchase for the proposed work?

None Anticipated

13. List at least three (3) similar projects completed within the last five (5) years by the bidder and the proposed project manager. For purposes of this requirement, 'similar' projects shall be considered to include wastewater treatment equipment



and mechanical piping systems. Include owner, project value, completion date, reference contact information and brief project description. The determination of whether a project is sufficiently similar shall be at the sole discretion of the City and the Engineer.

See attached similar projects

---

---

---

---

---

(Add sheets as requested.)

14. Name the Project Manager proposed for this project. Attach a copy of the project manager's resume.

Daniel Dion

---

NOTE: If requested by CITY, the Bidder shall furnish a notarized financial statement, references and other information, sufficiently comprehensive to permit an appraisal of its current financial condition.

**Current Contracts**

Owner	Name of Project	Total Contract Value	Completion Date	Term	% of Completion to Date
CITY OF W PALM BEACH	MASTER WATER TREATMENT PLANT	\$501,445.16	5/27/2024	TERM	80%
TOWN OF JUPITER	UTILITIES PAINTING MAINTENANCE- CONT. SERVICES TERM	\$1,459,308.00	11/2/2023	TERM	90%
CITY OF ST. PETE	Painting, Water-Proofing and Associated Services TERM	\$328,000.00	8/31/2023	TERM	80%
CHARLOTTE COUNTY	Re-Painting of Aerial Crossings	\$361,167.70	9/30/2023	TERM	80%
PALM BEACH COUNTY	PAINTING, WATERPROOFING & ASSOC. SERVICES	\$193,627.88	4/9/2023	TERM	95%
HERNANDO COUNTY	Hernando Beach Water Tower Maintenance TERM (9-28-21 trough 9-27-24)	\$82,060.00	9/27/2024	TERM	95%
PEACE RIVER MANASOTA REGIONAL WATER SUPPLY AUTHORITY	As Needed Painting & Coating Services 5-Year TERM (12/1/2021 through 12/1/2026)	\$328,162.56	12/1/2026	TERM	40%
SYNERGY NDS	City of Dunedin Walls & Ceiling Painting	\$93,700.00			90%
CITY OF MIRAMAR	Pool of Qualified GCs for Small Scale Commercial Rehab Projects	TBD	5/13/2024	TERM	TBD
CITY OF TREASURE ISLAND	Small Project GC Construction Services	TBD	5/3/2025	TERM	TBD
CLAY COUNTY UTILITY AUTHORITY	Ground Storage Tank Maintenance & Rehabilitation Services	TBD	5/26/2025	TERM	TBD
CITY OF CLEARWATER	WTP 3 East Dome and Aeator & Misc Improvements	\$1,791,334.60			5%
PASCO COUNTY (TERM)	As Needed Utilities General Maintenance Services(3-year Term)	\$97,045.00	11/18/2025	TERM	10%
BAY TO BAY PROPERTIES	Bubble Down Car Wash - New River	TBD			TBD
DESOTO COUNTY	Utilities Potable Water Tanks Repair & Maintenance	\$353,675.00			99%
CITY OF HOLLY HILL	WTP Chlorine Canopy Replacement	\$298,000.00	2/5/2023		100%
SYNERGY NDS	Water Treatment Plant Pipe & Motor	\$5,200.00			80%
FDEP	Gasparilla Island Hurricane Ian	\$277,000.00			70%
NEW SMYRNA BEACH UTILITIES	GWTP Lime Silo Structural Repairs	\$89,000.00	12/22/2022		100%
CITY OF QUINCY	WTP Ground Storage Tank Repair	\$30,000.00	1/18/2023		100%
LEE COUNTY	Pressure Washing Services	\$0.00	TBD	TERM	TBD
ROWLAND INC	City of Clearwater Stevenson Creek Bridge Piping Part 2	\$11,450.00	1/23/2023		100%
CITY OF PALM COAST	Elevated Tank Inspections	\$4,424.00	12/28/2023	TERM	100%
SUPERIOR SCHOOLS	Steeple Rehab	\$23,000.00	1/9/2023		100%
LEE COUNTY	Painting Services - Annual	TBD		TERM	TBD
CITY OF NORTH MIAMI BEACH	Norwood Sulfuric Acid Containment	\$128,350.00			0%

Ron DeSantis, Governor

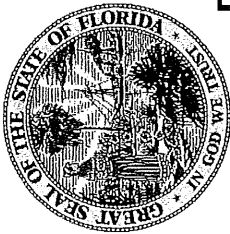

Melanie S. Griffin, Secretary



STATE OF FLORIDA  
DEPARTMENT OF BUSINESS AND PROFESSIONAL REGULATION

CONSTRUCTION INDUSTRY LICENSING BOARD

THE GENERAL CONTRACTOR HEREIN IS CERTIFIED UNDER THE  
PROVISIONS OF CHAPTER 489, FLORIDA STATUTES

**HOULLIS, ANTHONY MICHAEL**

RAZORBACK LLC  
177 ANCLOTE RD  
TARPOON SPRINGS FL 34689

LICENSE NUMBER: CGC1526612

EXPIRATION DATE: AUGUST 31, 2024

Always verify licenses online at [MyFloridaLicense.com](http://MyFloridaLicense.com)



Do not alter this document in any form.

This is your license. It is unlawful for anyone other than the licensee to use this document.

**RAZORBACK LLC - EQUIPMENT LIST**

**Last Modified 8/14/22**

<b>ID #</b>	<b>Status</b>	<b>Type</b>	<b>Year</b>	<b>Make</b>	<b>Model</b>
001	In Use	Trailer Enclosed	2019	ARNI	16x7x7h
002	In Use	Trailer Enclosed	2016	EAGL	16x7x6.5h
003	In Use	Trailer Enclosed	2018	QLCG	20x8.5x7h
004	In Use	Trailer Gooseneck	2003	CHAMPION	30x8
005	In Use	Trailer Open	2021	TCTC (Triple Crown)	24x7
006	In Use	Trailer Enclosed	2021	Cove (Covered Wagon)	24x8.5x7h
007	In Use	Trailer Enclosed	2020	ISO GA CARGO (SGAC)	14x7x7h
008	In Use	Trailer	2022	Homemade Pontoon Trail	24x8
009		Trailer	1996	USAT	TL
100		Truck	1990	Ford F800 (Blue)	TK
101		Truck	2017	Ford F-450 (Black)	TK Diesel
102		Trailer	1970	Homemade 25'	TV
103	In Use	Trailer	2001	CNTR	TL
104					
105	In Use	Blast Pot	1999	8-Ton With Dryer (#1)	Trailer 4 Shoe
106		Blast Pot	1985	6-Ton (#2)	Skid 2 Shoe
107		Blast Pot	1994	6-Ton (#3)	Skid 4 Shoe Key
108		Blast Pot		Small 8cf	Roller 1 Shoe Key
109					
110		Dust Collector	1996	Blast Tech - ASPT	45000 cfm
111		VACUUM			
112					
113		Paint Pump	2016	Graco Pneumatic	Xtreme NXT X60
114		Paint Pump		Graco Pneumatic	
115					
116					
117		Paint Pump	2018	Graco Gas	GH833
118		Air Compressor	1999	Ingersol Rand	375 CFM
119		Air Compressor		Sullair	375 CFM
120		Air Compressor	2008	Sullair	375 CFM
121		Air Compressor	2012	Sullair	375 CFM
122		Air Compressor	2006	Sullair	300 CFM
123					
124		Blast Pot	1999	Schmit	8 Ton
125		Air Drier	2001	Van Air	1600 CFM
126		Welder	Miller	Bobcat	
127		Concrete Pump		Quickspray	5210
128		DRYER		2100 CFM	SKID MOUNT
129		FORKLIFT		CATIPILLAR 8K	
130		SCISSOR LIFT		SKYJACK	SJII 3219
131					
132					
133		BOAT	2020	Rabco Fliver	8'
134		BARGE			30X12
135		BOAT		PONTOON BOAT	24X8



177 Anclote Road  
 Tarpon Springs, FL 34689  
 (727) 938-9500  
 info@razorbackllc.com  
 razorbackllc.com

### Similar Projects

1.

<b>Project Owner</b>	National Park Service
<b>Contact Name</b>	William Vazquez
<b>Contact Email</b>	William_vazquez@nps.gov
<b>Contact Phone #</b>	(305) 242-7793
<b>Project Value</b>	\$805,5000
<b>Contract Completion Date</b>	02/01/2021

Scope of Work: includes labor, materials, and equipment to rehabilitate the Flamingo Wastewater Treatment Plant. Work involved selective demolition, sludge removal, structural steel repairs, surface preparation, painting both interior & exterior walls of the membrane bioreactor and membrane treatment tanks, repaired steel piping, concrete form & pour, installing a sluice gate & actuators, replacing valves & flow systems, repairs to existing jet air systems, grouting, and patching using surfacing epoxy to repair voids/pits. Electrical improvements This consisted of the feeder power system and connections to motors, the installation of Instrumentation and Wiring Systems, the replacement of conduits and electrical wiring, the replacement of the panel air conditioning systems, all Bonding & grounding required, and the installation of new magnetic flow meters. Following installation, the new system was integrated with the existing control panel.

2.

<b>Project Owner</b>	City of Winter Haven
<b>Contact Name</b>	Terry Carver
<b>Contact Email</b>	tcarver@mywinterhaven.com
<b>Contact Phone #</b>	(863) 291-5766
<b>Project Value</b>	\$159,200
<b>Contract Completion Date</b>	09/11/2020

Scope of Work: Removed existing Clarifier Drive, cleaned and installed a new Clarifier Drive, surface preparation, sealed expansion joints and cracks, sludge removal, renewed gel coat on fiberglass reinforced plastic weirs and scum baffles, leveled weirs, inlet baffle ring, skimmers, and sludge collector arms, tested & adjusted torque switches for drive protection and painting & coating all new surfaces installed, existing steel surfaces within clarifier, and painting the concrete tank walls and concrete weir troughs.

3.

<b>Project Owner</b>	City of Atlantic Beach
<b>Contact Name</b>	Troy Stephens
<b>Contact Email</b>	tstephens@coab.us
<b>Contact Phone #</b>	(904) 588-4503
<b>Project Value</b>	\$168,900
<b>Contract Completion Date</b>	07/14/2021

Scope of Work: Removed the existing clarifier drives, clarifier bridges and associated hardware, and installed the new clarifier drives along with any necessary new hardware. Also, pressure washed, cleaned, and recoated the catwalk/bridge components at both clarifiers using Tnemec products.



177 Anclote Road  
Tarpon Springs, FL 34689  
(727) 938-9500  
info@razorbackllc.com  
razorbackllc.com

# Daniel Dion

Lead Project Manager

E-mail: dan@razorbackllc.com

Cell: 727.312.6694

## ***Professional Summary***

---

Results-driven professional with 10+ years experience managing construction projects. Focused on establishing an open and clear line of communication with clients and team members to deliver timely and accurate project completion. Proven track record successfully managing all phases of projects. Ensures safety compliance, administers budgets, controls expenses, and boosts efficiency and productivity.

## ***Skills***

---

- Leadership
- Communication
- Logistics
- Strategic Planning
- Negotiation
- Project Safety
- Estimating
- Organization
- Adaptability
- Problem Solving

## ***Experience***

---

**Razorback LLC • Lead Project Manager • 2021 to Present**

- Managing complete life cycle of projects- from planning to completion
- Coordinating project schedules to maximize efficiency and mitigate costs
- Ensuring site safety compliance
- Communicating with Owners to ensure client satisfaction

## ***Education***

---

**University of Rhode Island • 2001**

**FORM 16**

**PROPOSAL**

TO THE MAYOR AND COMMISSIONERS  
CITY OF HOLLYWOOD, FLORIDA

SUBMITTED 02/23/2023

Dear Mayor and Commissioners:

The undersigned, as BIDDER, hereby declares that the only person or persons interested in the Proposal as principal or principals is or are named herein and that no other person than herein mentioned has any interest in this Proposal or in the Contract to be entered into; that this Proposal is made without connection with any other person, company or parties making a Bid or Proposal; and that it is in all respects fair and in good faith without collusion or fraud.

The BIDDER further declares that he has examined the site of the Work and informed himself fully in regard to all conditions pertaining to the place where the Work is to be done; that he has examined the Drawings and Specifications for the Work and contractual documents relative thereto, including the Notice to Bidders, Instructions to Bidders, Proposal Bid Form, Form of Bid Bond, Form of Contract and Form of Performance Bond, General, Supplementary and Technical Specifications, Addenda, Drawings, and Local Preference Program, Exhibit A, and has read all of the Provisions furnished prior to the opening of bids; and that he has satisfied himself relative to the work to be performed.

The undersigned BIDDER has not divulged to, discussed or compared his bid with other bidders and has not colluded with any other BIDDER of parties to this bid whatever.

If this Proposal is accepted, the undersigned BIDDER proposes and agrees to enter into and execute the Contract with the City of Hollywood, Florida, in the form of Contract specified; of which this Proposal, Instructions to Bidders, General Specifications, Supplementary Conditions and Drawings shall be made a part for the performance of Work described therein; to furnish the necessary bond equal to one hundred (100) percent of the total Contract base bid, the said bond being in the form of a Cash Bond or Surety Bond prepared on the applicable approved bond form furnished by the CITY; to furnish all necessary materials, equipment, machinery, tools, apparatus, transportation, supervision, labor and all means necessary to construct and complete the work specified in the Proposal and Contract and called for in the Drawings and in the manner specified; to commence Work on the effective date established in the "Notice to Proceed" from the ENGINEER; and to substantially complete all Contract Work within 30 days with final completion within 45 days, and stated in the "Notice to Proceed" or pay liquidated damages for each calendar day in excess thereof, or such actual and consequential damages as may result therefrom, and to abide by the Local Preference Ordinance, Exhibit A.

The BIDDER acknowledges receipt of the following addenda:

No. <u>1</u>	Dated <u>1/11/23</u>
No. <u>2</u>	Dated <u>2/08/23</u>
No. <u>3</u>	Dated <u>2/15/23</u>
No. <u>4</u>	Dated <u>2/22/23</u>

And the undersigned agrees that in case of failure on his part to execute the said Contract and the Bond within ten (10) days after being presented with the prescribed Contract forms, the check or Bid Bond accompanying his bid, and the money payable thereon, shall be paid into the funds of the City of Hollywood, Florida, otherwise, the check or Bid Bond accompanying this Proposal shall be returned to the undersigned.

Attached hereto is a certified check on the

\_\_\_\_\_ Bank of \_\_\_\_\_

or approved Bid Bond for the sum of

Fourty Six Thousand Eight Hundred Ten Dollars and Fifty Cents Dollars (\$<sup>46,810.50</sup>) according to the conditions under the Instructions to Bidders and provisions therein.

NOTE: If a Bidder is a corporation, the legal name of the corporation shall be set forth below, together with signature(s) of the officer or officers authorized to sign Contracts on behalf of the corporation and corporate seal; if Bidder is a partnership, the true name of the firm shall be set forth below with the signature(s) of the partner or partners authorized to sign Contracts in behalf of the partnership; and if the Bidder is an individual, his signature shall be placed below; if a partnership, the names of the general partners.

WHEN THE BIDDER IS AN INDIVIDUAL:

\_\_\_\_\_  
(Signature of Individual)

\_\_\_\_\_  
(Printed Name of Individual)

\_\_\_\_\_  
(Address)

\*\*\*\*\*

WHEN THE BIDDER IS A SOLE PROPRIETORSHIP OR OPERATES UNDER A TRADE NAME:

\_\_\_\_\_  
(Name of Firm)

\_\_\_\_\_  
(Address)

\_\_\_\_\_  
(Signature of Individual) (SEAL)



\*\*\*\*\*

WHEN THE BIDDER IS A PARTNERSHIP:

\_\_\_\_\_  
(Name of Firm) A Partnership

\_\_\_\_\_  
(Address)

By: \_\_\_\_\_  
(SEAL)  
(Partner)

Name and Address of all Partners:

\_\_\_\_\_  
\_\_\_\_\_

\*\*\*\*\*

WHEN THE BIDDER IS A JOINT VENTURE:

\_\_\_\_\_  
(Correct Name of Corporation)

By: \_\_\_\_\_ (SEAL)  
(Address)

\_\_\_\_\_  
(Official Title)

As Joint Venture  
(Corporate Seal)

Organized under the laws of the State of \_\_\_\_\_, and authorized by the law to make this bid and perform all Work and furnish materials and equipment required under the Contract Documents.

\*\*\*\*\*

WHEN THE BIDDER IS A CORPORATION:

Razorback LLC  
\_\_\_\_\_  
(Correct Name of Corporation)

By: \_\_\_\_\_  
(SEAL)

MGRM  
\_\_\_\_\_



(Official Title)

177 Anclote Road, Tarpon Springs, FL 34689  
(Address of Corporation)

Organized under the laws of the State of Florida, and authorized by the law to make this bid and perform all Work and furnish materials and equipment required under the Contract Documents.

CERTIFIED COPY OF RESOLUTION OF  
BOARD OF DIRECTORS

Razorback LLC

(Name of Corporation)

RESOLVED that Anthony Houllis

(Person Authorized to Sign)

MGRM Razorback LLC of

(Title) (Name of Corporation)

be authorized to sign and submit the Bid or Proposal of this corporation for the following project:

**CLARIFIER NO. 3 REPAIR**  
**ECSD Project Number: 22-9525**  
**Bid No. REQ-038-23-JJ**

The foregoing is a true and correct copy of the Resolution adopted by

Razorback LLC at a meeting of its Board of  
(Name of Corporation)

Directors held on the 18th day of September, 2008.

By: 

Title: MGRM

(SEAL)

The above Resolution MUST BE COMPLETED if the Bidder is a Corporation.

- END OF SECTION -





177 Anclote Road  
Tarpon Springs, FL 34689  
(727) 938-9500  
info@razorbackllc.com  
razorbackllc.com

## Section III: Certificates of Insurance



# CERTIFICATE OF LIABILITY INSURANCE

DATE (MM/DD/YYYY)  
08/02/2022

**THIS CERTIFICATE IS ISSUED AS A MATTER OF INFORMATION ONLY AND CONFERS NO RIGHTS UPON THE CERTIFICATE HOLDER. THIS CERTIFICATE DOES NOT AFFIRMATIVELY OR NEGATIVELY AMEND, EXTEND OR ALTER THE COVERAGE AFFORDED BY THE POLICIES BELOW. THIS CERTIFICATE OF INSURANCE DOES NOT CONSTITUTE A CONTRACT BETWEEN THE ISSUING INSURER(S), AUTHORIZED REPRESENTATIVE OR PRODUCER, AND THE CERTIFICATE HOLDER.**

**IMPORTANT: If the certificate holder is an ADDITIONAL INSURED, the policy(ies) must have ADDITIONAL INSURED provisions or be endorsed. If SUBROGATION IS WAIVED, subject to the terms and conditions of the policy, certain policies may require an endorsement. A statement on this certificate does not confer rights to the certificate holder in lieu of such endorsement(s).**

<b>PRODUCER</b> Stahl & Associates Insurance Inc. 3939 Tampa Road Oldsmar FL 34677	<table border="1" style="width:100%; border-collapse: collapse;"> <tr> <td colspan="2">CONTACT NAME: Maribeth Patino</td> </tr> <tr> <td>PHONE (A/C, No, Ext): (813) 818-5300</td> <td>FAX (A/C, No): (813) 818-5396</td> </tr> <tr> <td colspan="2">E-MAIL ADDRESS: maribeth.patino@stahlinsurance.com</td> </tr> <tr> <td colspan="2" style="text-align: center;"><b>INSURER(S) AFFORDING COVERAGE</b></td> </tr> <tr> <td>INSURER A: Champlain Specialty Insurance Co</td> <td>NAIC #: 16834</td> </tr> <tr> <td>INSURER B: Auto Owners Insurance Co</td> <td>18988</td> </tr> <tr> <td>INSURER C: Westchester Surplus Lines Ins Co</td> <td>10172</td> </tr> <tr> <td>INSURER D:</td> <td></td> </tr> <tr> <td>INSURER E:</td> <td></td> </tr> <tr> <td>INSURER F:</td> <td></td> </tr> </table>	CONTACT NAME: Maribeth Patino		PHONE (A/C, No, Ext): (813) 818-5300	FAX (A/C, No): (813) 818-5396	E-MAIL ADDRESS: maribeth.patino@stahlinsurance.com		<b>INSURER(S) AFFORDING COVERAGE</b>		INSURER A: Champlain Specialty Insurance Co	NAIC #: 16834	INSURER B: Auto Owners Insurance Co	18988	INSURER C: Westchester Surplus Lines Ins Co	10172	INSURER D:		INSURER E:		INSURER F:	
CONTACT NAME: Maribeth Patino																					
PHONE (A/C, No, Ext): (813) 818-5300	FAX (A/C, No): (813) 818-5396																				
E-MAIL ADDRESS: maribeth.patino@stahlinsurance.com																					
<b>INSURER(S) AFFORDING COVERAGE</b>																					
INSURER A: Champlain Specialty Insurance Co	NAIC #: 16834																				
INSURER B: Auto Owners Insurance Co	18988																				
INSURER C: Westchester Surplus Lines Ins Co	10172																				
INSURER D:																					
INSURER E:																					
INSURER F:																					
<b>INSURED</b> Razorback LLC 177 Anclote Road Tarpon Springs FL 34689																					

**COVERAGES**    **CERTIFICATE NUMBER:** 22-23 Liab    **REVISION NUMBER:**

THIS IS TO CERTIFY THAT THE POLICIES OF INSURANCE LISTED BELOW HAVE BEEN ISSUED TO THE INSURED NAMED ABOVE FOR THE POLICY PERIOD INDICATED. NOTWITHSTANDING ANY REQUIREMENT, TERM OR CONDITION OF ANY CONTRACT OR OTHER DOCUMENT WITH RESPECT TO WHICH THIS CERTIFICATE MAY BE ISSUED OR MAY PERTAIN, THE INSURANCE AFFORDED BY THE POLICIES DESCRIBED HEREIN IS SUBJECT TO ALL THE TERMS, EXCLUSIONS AND CONDITIONS OF SUCH POLICIES. LIMITS SHOWN MAY HAVE BEEN REDUCED BY PAID CLAIMS.

INSR LTR	TYPE OF INSURANCE	ADDL INSD	SUBR VVD	POLICY NUMBER	POLICY EFF (MM/DD/YYYY)	POLICY EXP (MM/DD/YYYY)	LIMITS	
A	<input checked="" type="checkbox"/> <b>COMMERCIAL GENERAL LIABILITY</b> <input type="checkbox"/> CLAIMS-MADE <input checked="" type="checkbox"/> OCCUR  GEN'L AGGREGATE LIMIT APPLIES PER: <input type="checkbox"/> POLICY <input checked="" type="checkbox"/> PROJECT <input type="checkbox"/> LOC OTHER:			CSARCGL000071101	07/08/2022	07/08/2023	EACH OCCURRENCE	\$ 1,000,000
							DAMAGE TO RENTED PREMISES (Ea occurrence)	\$ 100,000
B	<input checked="" type="checkbox"/> <b>AUTOMOBILE LIABILITY</b> <input type="checkbox"/> ANY AUTO <input type="checkbox"/> SCHEDULED AUTOS <input type="checkbox"/> OWNED AUTOS ONLY <input type="checkbox"/> NON-OWNED AUTOS ONLY <input type="checkbox"/> HIRED AUTOS ONLY <input type="checkbox"/> AUTOS ONLY			5181816000	06/16/2022	06/16/2023	COMBINED SINGLE LIMIT (Ea accident)	\$ 1,000,000
							BODILY INJURY (Per person)	\$
							BODILY INJURY (Per accident)	\$
							PROPERTY DAMAGE (Per accident)	\$
A	<input checked="" type="checkbox"/> <b>UMBRELLA LIAB</b> <input checked="" type="checkbox"/> OCCUR <input type="checkbox"/> EXCESS LIAB <input type="checkbox"/> CLAIMS-MADE DED:   RETENTION \$			CSARCEL000071201	07/08/2022	07/08/2023	EACH OCCURRENCE	\$ 2,000,000
							AGGREGATE	\$ 2,000,000
C	<b>WORKERS COMPENSATION AND EMPLOYERS' LIABILITY</b> ANY PROPRIETOR/PARTNER/EXECUTIVE OFFICER/MEMBER EXCLUDED? (Mandatory in NH) <input type="checkbox"/> Y/N If yes, describe under DESCRIPTION OF OPERATIONS below			G71154920 005	07/08/2022	07/08/2023	PER STATUTE	OTH-ER
							E.L. EACH ACCIDENT	\$
							E.L. DISEASE - EA EMPLOYEE	\$
							E.L. DISEASE - POLICY LIMIT	\$
	Contractor's Pollution Liability						Each Pollution Condition	\$2,000,000
							Aggregate	\$2,000,000

DESCRIPTION OF OPERATIONS / LOCATIONS / VEHICLES (ACORD 101, Additional Remarks Schedule, may be attached if more space is required)

<b>CERTIFICATE HOLDER</b>  FOR PROPOSAL PURPOSES ONLY	<b>CANCELLATION</b>  SHOULD ANY OF THE ABOVE DESCRIBED POLICIES BE CANCELLED BEFORE THE EXPIRATION DATE THEREOF, NOTICE WILL BE DELIVERED IN ACCORDANCE WITH THE POLICY PROVISIONS.  AUTHORIZED REPRESENTATIVE 
---	--



# CERTIFICATE OF LIABILITY INSURANCE

DATE (MM/DD/YYYY)

10/28/2022

THIS CERTIFICATE IS ISSUED AS A MATTER OF INFORMATION ONLY AND CONFERS NO RIGHTS UPON THE CERTIFICATE HOLDER. THIS CERTIFICATE DOES NOT AFFIRMATIVELY OR NEGATIVELY AMEND, EXTEND OR ALTER THE COVERAGE AFFORDED BY THE POLICIES BELOW. THIS CERTIFICATE OF INSURANCE DOES NOT CONSTITUTE A CONTRACT BETWEEN THE ISSUING INSURER(S), AUTHORIZED REPRESENTATIVE OR PRODUCER, AND THE CERTIFICATE HOLDER.

**IMPORTANT:** If the certificate holder is an ADDITIONAL INSURED, the policy(ies) must have ADDITIONAL INSURED provisions or be endorsed. If SUBROGATION IS WAIVED, subject to the terms and conditions of the policy, certain policies may require an endorsement. A statement on this certificate does not confer rights to the certificate holder in lieu of such endorsement(s).

<b>PRODUCER</b> SUNZ Insurance Solutions, LLC. ID: (TLR) c/o TLR of Bonita, Inc 700 Central Ave, Suite 500 St. Petersburg, FL 33701	<b>CONTACT NAME:</b> Workers' Comp Department	
	<b>PHONE (A/C, No, Ext):</b> 727-520-7676 x 3	<b>FAX (A/C, No):</b> 727-525-3862
<b>E-MAIL ADDRESS:</b> certs@encorehr.com		
<b>INSURER(S) AFFORDING COVERAGE</b>		<b>NAIC #</b>
<b>INSURER A :</b> SUNZ Insurance Company		34762
<b>INSURER B :</b>		
<b>INSURER C :</b>		
<b>INSURER D :</b>		
<b>INSURER E :</b>		
<b>INSURER F :</b>		

**INSURED**  
 TLR of Bonita, Inc  
 dba EnterpriseHR  
 700 Central Avenue Suite 500  
 St. Petersburg FL 33701

**COVERAGES**

CERTIFICATE NUMBER: 71027414

REVISION NUMBER:

THIS IS TO CERTIFY THAT THE POLICIES OF INSURANCE LISTED BELOW HAVE BEEN ISSUED TO THE INSURED NAMED ABOVE FOR THE POLICY PERIOD INDICATED. NOTWITHSTANDING ANY REQUIREMENT, TERM OR CONDITION OF ANY CONTRACT OR OTHER DOCUMENT WITH RESPECT TO WHICH THIS CERTIFICATE MAY BE ISSUED OR MAY PERTAIN, THE INSURANCE AFFORDED BY THE POLICIES DESCRIBED HEREIN IS SUBJECT TO ALL THE TERMS, EXCLUSIONS AND CONDITIONS OF SUCH POLICIES. LIMITS SHOWN MAY HAVE BEEN REDUCED BY PAID CLAIMS.

INSR LTR	TYPE OF INSURANCE	ADDL INSD	SUBR WVD	POLICY NUMBER	POLICY EFF (MM/DD/YYYY)	POLICY EXP (MM/DD/YYYY)	LIMITS
	<b>COMMERCIAL GENERAL LIABILITY</b> <input type="checkbox"/> CLAIMS-MADE <input type="checkbox"/> OCCUR  GEN'L AGGREGATE LIMIT APPLIES PER: <input type="checkbox"/> POLICY <input type="checkbox"/> PRO-JECT <input type="checkbox"/> LOC OTHER:						EACH OCCURRENCE \$ DAMAGE TO RENTED PREMISES (Ea occurrence) \$ MED EXP (Any one person) \$ PERSONAL & ADV INJURY \$ GENERAL AGGREGATE \$ PRODUCTS - COMP/OP AGG \$ \$
	<b>AUTOMOBILE LIABILITY</b> <input type="checkbox"/> ANY AUTO <input type="checkbox"/> OWNED AUTOS ONLY <input type="checkbox"/> HIRED AUTOS ONLY <input type="checkbox"/> SCHEDULED AUTOS <input type="checkbox"/> NON-OWNED AUTOS ONLY						COMBINED SINGLE LIMIT (Ea accident) \$ BODILY INJURY (Per person) \$ BODILY INJURY (Per accident) \$ PROPERTY DAMAGE (Per accident) \$ \$
	<b>UMBRELLA LIAB</b> <input type="checkbox"/> OCCUR <b>EXCESS LIAB</b> <input type="checkbox"/> CLAIMS-MADE DED RETENTION \$						EACH OCCURRENCE \$ AGGREGATE \$ \$
A	<b>WORKERS COMPENSATION AND EMPLOYERS' LIABILITY</b> ANY PROPRIETOR/PARTNER/EXECUTIVE OFFICER/MEMBER EXCLUDED? (Mandatory in NH) If yes, describe under DESCRIPTION OF OPERATIONS below		N/A	WC039-00001-022	6/1/2022	6/1/2023	<input checked="" type="checkbox"/> PER STATUTE <input type="checkbox"/> OTHER E.L. EACH ACCIDENT \$ 1,000,000.00 E.L. DISEASE - EA EMPLOYEE \$ 1,000,000.00 E.L. DISEASE - POLICY LIMIT \$ 1,000,000.00

DESCRIPTION OF OPERATIONS / LOCATIONS / VEHICLES (ACORD 101, Additional Remarks Schedule, may be attached if more space is required)

Coverage Provided for all leased employees but not subcontractors of: Razorback LLC  
 Client Effective: 09/28/2020

**CERTIFICATE HOLDER**

441  
 Razorback LLC  
 177 Anclote Road  
 Tarpon Springs, FL 34689

**CANCELLATION**

SHOULD ANY OF THE ABOVE DESCRIBED POLICIES BE CANCELLED BEFORE THE EXPIRATION DATE THEREOF, NOTICE WILL BE DELIVERED IN ACCORDANCE WITH THE POLICY PROVISIONS.

AUTHORIZED REPRESENTATIVE

Rick Leonard

© 1988-2015 ACORD CORPORATION. All rights reserved.



177 Anclote Road  
Tarpon Springs, FL 34689  
(727) 938-9500  
info@razorbackllc.com  
razorbackllc.com

**Section IV: Proof of State of Florida**

**Sunbiz Registration**



Department of State / Division of Corporations / Search Records / Search by Entity Name /

## Detail by Entity Name

Florida Limited Liability Company  
RAZORBACK LLC

### Filing Information

**Document Number** L08000089307  
**FEI/EIN Number** 26-3447303  
**Date Filed** 09/18/2008  
**State** FL  
**Status** ACTIVE  
**Last Event** REINSTATEMENT  
**Event Date Filed** 02/22/2011

### Principal Address

177 Anclote Road  
TARPON SPRINGS, FL 34689

Changed: 02/08/2021

### Mailing Address

177 Anclote Road  
TARPON SPRINGS, FL 34689

Changed: 02/08/2021

### Registered Agent Name & Address

HOULLIS, ANTHONY M  
276 KNOLLWOOD ROAD  
TARPON SPRINGS, FL 34688

### Authorized Person(s) Detail

#### **Name & Address**

Title MGRM

HOULLIS, ANTHONY M  
276 KNOLLWOOD ROAD  
TARPON SPRINGS, FL 34688

### Annual Reports

Report Year	Filed Date
2021	02/08/2021

2022 01/26/2022  
2023 01/23/2023

**Document Images**

<a href="#">01/23/2023 -- ANNUAL REPORT</a>	View image in PDF format
<a href="#">01/26/2022 -- ANNUAL REPORT</a>	View image in PDF format
<a href="#">02/08/2021 -- ANNUAL REPORT</a>	View image in PDF format
<a href="#">01/21/2020 -- ANNUAL REPORT</a>	View image in PDF format
<a href="#">02/21/2019 -- ANNUAL REPORT</a>	View image in PDF format
<a href="#">01/15/2018 -- ANNUAL REPORT</a>	View image in PDF format
<a href="#">04/05/2017 -- ANNUAL REPORT</a>	View image in PDF format
<a href="#">02/01/2016 -- ANNUAL REPORT</a>	View image in PDF format
<a href="#">01/11/2015 -- ANNUAL REPORT</a>	View image in PDF format
<a href="#">01/16/2014 -- ANNUAL REPORT</a>	View image in PDF format
<a href="#">01/18/2013 -- ANNUAL REPORT</a>	View image in PDF format
<a href="#">01/05/2012 -- ANNUAL REPORT</a>	View image in PDF format
<a href="#">02/22/2011 -- REINSTATEMENT</a>	View image in PDF format
<a href="#">03/04/2009 -- ANNUAL REPORT</a>	View image in PDF format
<a href="#">09/18/2008 -- Florida Limited Liability</a>	View image in PDF format



ATTACHMENT A  
CONTRACT

THIS AGREEMENT, made and entered into, this \_\_\_\_ day of \_\_\_\_\_, A.D., \_\_\_\_\_, by and between the CITY OF HOLLYWOOD, Florida, a municipal corporation of the State of Florida, part of the first part, (hereinafter sometimes called the "CITY"), and

party of the second part (hereinafter sometimes called the "CONTRACTOR").

WITNESSETH: The parties hereto, for the considerations herein-after set forth, mutually agree as follows:

Article 1. Scope of Work: The CONTRACTOR shall furnish all labor, materials, and equipment and perform all work in the manner and form provided by the Contract Documents, for:

**Clarifier No. 3 Repair  
Project No. 22-9525**

Article 2. The Contract Sum: The CITY shall pay to the CONTRACTOR, for the faithful performance of the Contract, in lawful money of the United States of America, and subject to additions and deductions as provided in the Contract Documents, as follows:

Based upon the prices shown in the Proposal heretofore submitted to the CITY by the CONTRACTOR, a copy of said Proposal being a part of these Contract Documents, the aggregate amount of this Contract being the sum of

Article 3. Partial and Final Payments: In accordance with the provisions fully set forth in the "General Conditions" of the "Specifications", and subject to additions and deductions as provided, the CITY shall pay the CONTRACTOR as follows:

- (a) On the 15th day, or the first business day thereafter, of each calendar month, the CITY shall make partial payments to the CONTRACTOR on the basis of a duly certified and approved estimate of work performed during the preceding calendar month by the CONTRACTOR, less five percent (5%) of the amount of such estimate which is to be retained by the CITY until all work has been performed strictly in accordance with this Agreement and until such work has been accepted by the CITY. The parties' rights and obligations regarding retainage are further specified in Florida Statute Section 218.735.
- (b) Upon submission by the CONTRACTOR of evidence satisfactory to the CITY that all payrolls, material bills and other costs incurred by the CONTRACTOR in connection with the construction of the WORK have been paid in full, and also, after all guarantees that may be required in the Specifications have been furnished and are found acceptable by the CITY, final payment on account of this Agreement shall be made within sixty (60) days after completion by the CONTRACTOR of all work covered by this Agreement and acceptance of such work by the ENGINEER and approved by the CITY.

Article 4. Time of Completion: The CONTRACTOR shall commence work to be performed under this Contract within ten (10) consecutive calendar days after date of written Notice To Proceed and shall fully complete the Contract in accordance within the Contract Documents and meet all intermediate milestone completion dates required after said date of written notice as set forth in the Proposal, as may be modified by Instructions to Bidders, and stated in the Notice to Proceed.

It is mutually agreed between the parties hereto, that time is the essence, and in the event that construction of the WORK is not completed within the Contract Time and per intermediate dates, as may have been modified solely in accordance with the General Conditions of this Contract, that from the compensation otherwise to be paid to the CONTRACTOR, the CITY is authorized and shall retain, for each day thereafter, Sundays and holidays included, the sum set forth in the Supplementary General Conditions of this Contract as liquidated damages sustained by the CITY in the event of such default by the CONTRACTOR, or shall withhold such compensation for actual and consequential damages as may be stated therein or contemplated therefrom.

Article 5. Additional Bond: It is further mutually agreed between the parties hereto, that if, at any time after the execution of this Agreement and the Payment and Performance Bonds required herein for the express purpose of assuring the faithful performance of the Contractor's work hereto attached, the CITY shall deem the surety or sureties' to be unsatisfactory, or, if for any reason, said bonds cease to be adequate to cover the performance of the work, the CONTRACTOR shall, at his expense, within five (5) days after receipt of notice from the CITY furnish an additional bond or bonds in such form and amount, and with such surety or sureties as shall be satisfactory to the CITY. In such event, no further payment to the CONTRACTOR shall be deemed to be due under this agreement until such new or additional security for the faithful performance of the work shall be furnished in manner and form satisfactory to the CITY.

Article 6. Contract Documents: All of the documents hereinafter listed form the Contract and they are as fully a part of the Contract as if hereto attached, or repeated in this Agreement:

1.	Introduction	15.	General Terms and Conditions
2.	Special Terms and Conditions	16.	Scope of Services
3.	Submittal Checklist Form	17.	Contract
4.	Acknowledgement and Signature Page	18.	Drug-Free Workplace Program
5.	Bid Form	19.	Solicitation, Giving, and Acceptance...
6.	Vendor Reference Form	20.	W-9 (Request for Taxpayer Identification)
7.	Hold Harmless and Indemnity Clause	21.	Performance Bond
8.	Proposal	22.	Payment Bond
9.	Non-Collusion Affidavit	23.	General Conditions, Public Utilities
10.	Sworn Statement...Public Entity Crimes	24.	Supplementary General Conditions
11.	Information Required from Bidders	25.	Addenda
12.	Certifications Regarding Debarment...	26.	Specifications
13.	Trench Safety Form	27.	Drawings
14.	Bid Guaranty Form	28.	List of Subcontractors

Article 7. The rate of wages and fringe benefits, or cash equivalent, for all laborers, mechanics and apprentices employed by any contractor or subcontractor on the work covered by the contract shall be not less than the prevailing rate of wages and fringe benefit payments or cash equivalent for similar skills or classifications of work as established by the General Wage Decision by the United States Department of Labor for Broward County, Florida that is in effect prior to the date the city issues its invitation for bids. If the General Wage Decision fails to provide for a fringe benefit rate for any worker classification, then the fringe benefit rate applicable to the worker classification shall be the fringe benefit rate applicable to the worker classification with a fringe benefit rate that has a basic hourly wage closest in dollar amount to the worker classification for which no fringe benefit rate has been provided.

Article 8. No additional work or extras shall be performed unless the same be duly authorized by appropriate action of the City.

Article 9. That in the event either party brings suit for enforcement of disagreement, the prevailing party shall be entitled to attorney's fees and court costs in addition to any other remedy afforded by law.

Article 10. The Contractor shall guarantee the complete project against poor workmanship and faulty materials for a period of twelve (12) months after final payment and shall immediately correct any defects which may appear during this period upon notification by the City or the Engineer.

Article 11. The making and acceptance of the final payment shall constitute a waiver of all claims by the Contractor, except those previously made and still unsettled.

\*\*\*\*\*

IN WITNESS WHEREOF the parties hereto have executed this Agreement on the day and date first above written in three (3) counterparts, each of which shall, without proof or accounting for the other counterparts, be deemed an original contract:

THE CITY OF HOLLYWOOD, FLORIDA  
Party of the First Part

By: \_\_\_\_\_ (SEAL)  
JOSH LEVY, MAYOR

ATTEST:

\_\_\_\_\_  
PATRICIA A. CERNY, MMC  
City Clerk

\*\*\*\*\*

CONTRACTOR  
Party of the Second Part

WHEN THE CONTRACTOR IS AN INDIVIDUAL:

Signed, sealed and delivered in the presence of:

_____	_____ (SEAL)
(Witness)	(Signature of Individual)
_____	_____
(Witness)	(Signature of Individual)

\*\*\*\*\*

WHEN THE CONTRACTOR IS A SOLE PROPRIETORSHIP OR OPERATES UNDER A TRADE NAME:

Signed, sealed and delivered in the presence of:

_____	_____
(Witness)	(Name of Firm)
_____	_____ (SEAL)
(Witness)	(Signature of Individual)

\*\*\*\*\*

WHEN THE CONTRACTOR IS A PARTNERSHIP:

_____	_____
(Witness)	(Name of Firm) a Partnership
_____	BY: _____ (SEAL)
(Witness)	(Partner)

\*\*\*\*\*

WHEN THE CONTRACTOR IS A CORPORATION:

Attest:

\_\_\_\_\_  
Secretary

\_\_\_\_\_  
(Correct Name of Corporation)

BY: \_\_\_\_\_ (SEAL)  
President

\*\*\*\*\*

APPROVED AS TO FORM  
AND LEGAL SUFFICIENCY  
for the use and reliance of the  
City of Hollywood, Florida only:

APPROVED AS TO FINANCE:

By \_\_\_\_\_  
DOUGLAS R. GONZALES  
City Attorney

By \_\_\_\_\_  
David E. Keller  
Financial Services Director

CERTIFICATE

**STATE OF FLORIDA)  
COUNTY OF BROWARD)**

***I HEREBY CERTIFY*** that a meeting of the Board of Directors of \_\_\_\_\_,  
a corporation under the laws of the State of \_\_\_\_\_, was held on \_\_\_\_\_,  
20\_\_, and the following resolution was duly passed and adopted:

"RESOLVED, that \_\_\_\_\_ as \_\_\_\_\_ President of the corporation,  
be and he is hereby authorized to execute the contracts on behalf of this  
corporation, and that his execution thereof, attested by the Secretary of  
the corporation and with corporate seal affixed, shall be the official act and  
deed of this corporation."

I further certify that said resolution is now in full force and effect.

IN WITNESS WHEREOF, I have hereunto set my hand and affixed the official seal of  
the corporation, this \_\_\_\_\_ day of \_\_\_\_\_, 20\_\_.

\_\_\_\_\_  
Secretary

- END OF SECTION -

ATTACHMENT A  
PAYMENT BOND

KNOW ALL MEN BY THESE PRESENTS:

That we, \_\_\_\_\_  
Name Address Tel. No.

As Principal and \_\_\_\_\_  
Name Address Tel. No.

as Surety, are held and firmly bound to the CITY OF HOLLYWOOD, FLORIDA herein called the City, in the sum of \_\_\_\_\_

\_\_\_\_\_ Dollars (\$ \_\_\_\_\_) for the payment of said sum we bind ourselves, our heirs, executors, administrators and assigns, jointly and severally, for the faithful performance of a certain written contract dated the \_\_\_\_\_ day of \_\_\_\_\_, 20\_\_\_\_, entered into between the Principal and the City of Hollywood, Florida for the **Clarifier No. 3 Repair, Project No. 22-9525.**

Which contract is by reference made a part hereof, and is hereinafter referred to as the Contract.

THE CONDITION of this bond is that if Principal promptly makes payments to all claimants defined in Section 255.05 (1), F.S., supplying Principal with labor, materials or supplies used directly or indirectly by principal in the prosecution of the work provided for in the Contract, then this bond shall be null and void and of no further force and effect; otherwise to remain in full force and effect.

Said surety for value received hereby stipulates and agrees that no change, extension of time, alteration or addition to the terms of the contract or any other changes in or under contract documents and compliance or noncompliance with any formalities connected with the contract does not affect Surety's obligation under this bond and Surety waives notice of any such change, extension of time, alteration or addition to the terms of the Contract or any other changes, compliance, or noncompliance to the terms of the Contract or to the Work or to the Specifications.

This bond is furnished pursuant to the statutory requirements for bond on public works projects being Florida Statute 255.05. Claimants are hereby notified that the Statute 255.05(2) specifically requires that notice be given to Contractor within 45 days after beginning to furnish labor, materials or supplies for the prosecution of the work that claimants intends to look to the bond for protection. Further notice is hereby given claimants that written notice of nonpayment within ninety (90) days after performance of the labor or after complete delivery of the materials or supplies must be delivered to the Contractor and to the Surety. Further notice is hereby given that no action for labor, materials or supplies may be instituted against the Contractor or the Surety on the bond after one year for the performance of the labor or completion of delivery of the materials or supplies.

Without modifying the foregoing, this bond shall be construed as requiring of the principal and surety no more and no less than is specified in F.S. 255.050.

SIGNED AND SEALED, this \_\_\_\_\_ day of \_\_\_\_\_, 20\_\_\_\_.

**PRINCIPAL:**

ATTEST:

\_\_\_\_\_  
\_\_\_\_\_

\_\_\_\_\_  
(Signature)

\_\_\_\_\_  
(Title)

(SEAL)

**SURETY:**

\_\_\_\_\_  
(Surety)

ATTEST:

\_\_\_\_\_  
\_\_\_\_\_

\_\_\_\_\_  
(Signature)

\_\_\_\_\_  
(Attorney-in-Fact)

\*\*\*\*\*

APPROVED AS TO FORM AND  
LEGAL SUFFICIENCY  
for the use and reliance of the  
City of Hollywood, Florida only:

APPROVED AS TO FINANCE:

By \_\_\_\_\_  
Douglas R. Gonzales  
City Attorney

By \_\_\_\_\_  
David E. Keller  
Financial Services Director

- END OF SECTION -



ATTACHMENT A  
PERFORMANCE BOND

KNOW ALL MEN BY THESE PRESENTS:

That we \_\_\_\_\_,  
Name Address Tel. No.

as Principal, and \_\_\_\_\_,  
Name Address Tel. No.

as Surety, are held and firmly bound unto the City of Hollywood in the sum of \_\_\_\_\_ Dollars (\$\_\_\_\_\_), for the payment of said sum we bind ourselves, our heirs, executors, administrators and assigns, jointly and severally, for the faithful performance of a certain written contract, dated the \_\_\_\_\_ day of \_\_\_\_\_, 20\_\_\_\_ entered into between the Principal and the City of Hollywood, Florida, for the installation of **Clarifier No. 3 Repair, Project No. 22-9525**.

A copy of said Contract, **No. 22-9525** is incorporated herein by reference and is made a part hereof as if fully copied herein.

NOW, THEREFORE, THE CONDITIONS OF THIS OBLIGATION ARE SUCH, that if the Principal shall in all respects comply with the terms and conditions of said Contract and his obligations thereunder, including all of the Contract Documents (that include the Introduction, Special Terms and Conditions, Scope of Services, General Terms & Conditions, Submittal Checklist Form, Instructions to Bidders, Proposal, Proposal Bid Form, Basis of Payment, Bid Guaranty Form, Trench Safety Form, Information Required from Bidders, Vendor Reference Forms, Hold Harmless and Indemnity Clause, Non-Collusion Affidavit, Sworn Statement...Public Entity Crimes, Certifications Regarding Debarment... , Drug-Free Workplace Program, Solicitation, Giving, and Acceptance..., Contract, Performance Bond, Payment Bond, General and Supplementary General Conditions, Technical Specifications, Addenda and Drawings), therein referred to and made a part thereof, and such alterations as may be made in said Drawings and Specifications as therein provided for, and shall indemnify and save harmless the City of Hollywood against and from all expenses, damages, injury or conduct, want of care of skill, negligence or default, including patent infringement on the part of said Principal, his agents or employees, in the execution or performance of said Contract, including errors in the Drawings furnished by said Principal, and further, if the Principal shall promptly make payments to all who supply him, with labor and/or materials, used directly or indirectly by the Principal in the prosecution of the work provided for in said Contract, then this obligation shall be null and void; otherwise, the Principal and Surety, jointly and severally, agree to pay the City of Hollywood any difference between the sum that the City of Hollywood may be obliged to pay for the completion of said work, by Contract or otherwise, and the sum that the City of Hollywood would have been obliged to pay for the completion said work had the Principal properly executed all of the provisions of said Contract, and any damages, whether direct, indirect, or consequential, which the City of Hollywood may incur as a result of the failure of the said Principal to properly execute all of the provisions of said Contract.

AND, the said Principal and Surety hereby further bind themselves, their successors, executors, administrators and assigns, jointly and severally, that they will amply and fully protect the City of Hollywood against, and will pay any and all amounts, damages, costs and judgments which may be recovered against or which the Owner may be called upon to pay to any person or corporation by reason of any damage arising from the performance of the said work, repair or maintenance thereof, or the manner of doing the same, or his agents or his servants, or the infringements of any patent rights by reason of the use of any material furnished or work done, as aforesaid or otherwise.

AND, the said Surety, for value received, hereby stipulates and agrees that no change, extension of time, alteration or addition to the terms of the Contract or to the work to be performed thereunder or the Specifications and Drawings accompanying the same, shall in any way affect its obligations on this Bond, and it does hereby waive notice of any such change, extension of time, alteration or addition to the terms of the Contract or to the work or to the Specifications and Drawings.

WHEN THE PRINCIPAL IS AN INDIVIDUAL:

Signed, sealed and delivered in the presence of:

\_\_\_\_\_  
(Witness)

\_\_\_\_\_  
(Signature of Individual)

\_\_\_\_\_  
(Address)

\_\_\_\_\_  
(Printed Name of Individual)

\_\_\_\_\_  
(Witness)

\_\_\_\_\_  
(Address)

WHEN THE PRINCIPAL IS A SOLE PROPRIETORSHIP OR OPERATES UNDER A TRADE NAME:

Signed, sealed and delivered in the presence of:

\_\_\_\_\_  
(Witness)

\_\_\_\_\_  
(Name of Firm)

\_\_\_\_\_  
(Address)

By: \_\_\_\_\_  
(Seal)  
(Signature of Individual)

\_\_\_\_\_  
(Witness)

\_\_\_\_\_  
Address

\*\*\*\*\*

WHEN THE PRINCIPAL IS A PARTNERSHIP:

Signed, sealed and delivered in the presence of:

\_\_\_\_\_  
(Witness)

\_\_\_\_\_  
(Name of Partnership)

\_\_\_\_\_  
(Address)

By: \_\_\_\_\_  
(Seal)  
(Partner)

\_\_\_\_\_  
(Witness)

\_\_\_\_\_  
(Printed Name of Partner)

\_\_\_\_\_  
Address

\*\*\*\*\*

WHEN THE PRINCIPAL IS A CORPORATION:

Attest:

\_\_\_\_\_  
(Secretary)

\_\_\_\_\_  
(Name of Corporation)

By: \_\_\_\_\_  
(Seal)  
(Affix Corporate Seal)

\_\_\_\_\_  
(Printed Name)

\_\_\_\_\_  
(Official Title)

CERTIFICATE AS TO CORPORATE PRINCIPAL

I, \_\_\_\_\_, certify that I am the Secretary of the corporation named as Principal in the within bond; that \_\_\_\_\_, who signed the said bond on behalf of the Principal was then \_\_\_\_\_ of said corporation; that I know his signature, and his signature thereto is genuine; and that said Bond was duly signed, sealed and attested for and on behalf of said corporation by authority of its governing body.

\_\_\_\_\_  
Secretary (SEAL)

TO BE EXECUTED BY CORPORATE SURETY

Attest:

\_\_\_\_\_  
(Secretary)

\_\_\_\_\_  
(Corporate Surety)

\_\_\_\_\_  
(Business Address)

By: \_\_\_\_\_  
(Affix Corporate Seal)

\_\_\_\_\_  
(Attorney-In-Fact)

\_\_\_\_\_  
(Name of Local Agency)

\_\_\_\_\_  
(Business Address)

STATE OF FLORIDA

Before me, a Notary Public, duly commissioned, qualified and acting, personally appeared, \_\_\_\_\_ to me well known, who being by me first duly sworn upon oath, says that he is the attorney-in-fact for the \_\_\_\_\_ and that he has been authorized by \_\_\_\_\_ to execute the foregoing bond on behalf of the CONTRACTOR named therein in favor of the City of Hollywood, Florida.

Subscribed and sworn to before me this \_\_\_\_\_ day of \_\_\_\_\_, 20\_\_\_\_.

\_\_\_\_\_  
Notary Public, State of Florida

My Commission Expires:

\*\*\*\*\*

APPROVED AS TO FORM AND  
LEGAL SUFFICIENCY  
for the use and reliance of the  
City of Hollywood, Florida only:

APPROVED AS TO FINANCE:

By \_\_\_\_\_  
Douglas R. Gonzales  
City Attorney

By \_\_\_\_\_  
David E. Keller  
Financial Services Director

- END OF SECTION -

ATTACHMENT B

GENERAL CONDITIONS, PUBLIC UTILITIES

Index to Articles

		<u>Page</u>
Article 1	Definitions	5-7
Article 2	Organizational Abbreviations	8-9
Article 3	Miscellaneous Preliminary Matters	
3.1	Contract Document Discrepancies	10
3.2	Submissions	10
3.3	Pre-Construction Conference	10
3.4	Contract Time	10
3.5	Computation of Time	10
3.6	Commencement of Work	10
3.7	Extension of Contract Time	11
3.8	Notice and Service Thereof	11
3.9	Separate Contract	11
3.10	Assignments of Contract	11
3.11	Patents	11
3.12	Federal Excise Tax	12
3.13	Savings Due to Excise Tax Exemptions	12
3.14	Overtime Work	13
3.15	Inspections and Testing During Overtime	13
3.16	Nights, Sunday or Holiday Work	13
3.17	Injury or Damage Claims	13
Article 4	Contract Documents	
4.1	Intent	14
4.2	Order of Precedence of Contract Documents	14
4.3	Reference to Standards	14
Article 5	Bonds and Insurance	
5.1	Bid Guarantee	15
5.2	Performance and Payment Bond	15
5.3	Signatures	15
5.4	Insurance Coverage	15
5.5	Certificates of Insurance	15
5.6	Insurance Limits of Liability	16

		<b><u>Page</u></b>
Article 6	Availability of Land; Reference Points	
6.1	Rights-Of-Way	17
6.2	Permits	17
6.3	Lines and Grades	17
Article 7	Contractor's Responsibilities	
7.1	Laws/Regulations to Be Observed	18
7.2	Indemnification of City	18
7.3	Guarantee of Payments	18
7.4	Permits and Licenses	18
7.5	Emergencies	19
7.6	Substitutes or "Or Equal"	19-20
7.7	Shop Drawings	21
7.8	Personnel	22-23
7.9	Safety and Protection	23
7.10	Traffic Control, Public Safety and Convenience	24
7.11	Use of Explosives	25
7.12	Loading of Structures	25
7.13	Concerning Subcontractors	25
7.14	Materials and Equipment	25-27
7.15	Temporary Utilities	27
7.16	Review of Records	27
7.17	Use of Premises	27
7.18	Contractor's Daily Reports	28
7.19	Record Documents	28
7.20	Cleanliness of the Site	28
7.21	Dust Control	28
7.22	Continuing the Work	28
7.23	Indemnification	28-29
Article 8	City's Responsibility	
8.1	Communications	30
8.2	Furnish Contract Documents	30
8.3	Furnish Right-of-Way	30
8.4	Timely Delivery of Materials	30
Article 9	Engineer's Status	
9.1	Authority of the Engineer	31
9.2	Access to the Work	31
9.3	Limitations on the Engineer's Responsibilities	32
9.4	Inspectors	32-33
9.5	Inspections	33

		<b><u>Page</u></b>
Article 10	Changes in the Work/Contract Price	
10.1	Changes in Work or Terms of Contract Documents	34
10.2	Supplemental Instructions - Clarifications	34
10.3	Field Orders/Change Orders	34-35
10.4	Value of Change Order Work	35-39
10.5	Notification and Claim for Change of Contract Price	39
10.6	Notice of Change	39
10.7	Records	40
10.8	Cancelled Items and Payments Therefore	40
10.9	Full Payment	40
Article 11	Changes in the Contract Time	
11.1	Change Order	41
11.2	Notification and Claim for Change of Contract Time	41
11.3	Basis for Extension	41
11.4	Change of Time due to Contract Execution Problems	42
11.5	Change of Time due to Change Order Evaluation	42
11.6	Change of Time and Inspection and Testing	42
11.7	Change of Time and Defective Work	42
11.8	Liquidated Damages	42
Article 12	Warranty and Guarantee; Test and Inspections; Correction, Removal or Acceptance of Defective Work	
12.1	Warranty and Guarantee	43
12.2	Tests and Inspections	43
12.3	Uncovering Work	43-44
12.4	City May Stop the Work	44
12.5	Correction or Removal of Defective Work	44
12.6	One Year Correction Period	44
12.7	Acceptance of Defective Work	45
12.8	City May Correct Defective Work	45
Article 13	Payments to the Contractor	
13.1	Basis of Payment	46
13.2	Unit Price Inclusion	46
13.3	Schedule of Values	46
13.4	Changed Conditions	46
13.5	Application for Progress Payment	46
13.6	Payment for Materials	47
13.7	Affidavit Required	47
13.8	Retainage	47
13.9	Contractor's Warranty of Title	47
13.10	Review of Application for Payment	47-48
13.11	Payment to the Contractor	48



		<b><u>Page</u></b>
Article 14	Substantial Completion, Partial Utilization, Final Clean Up, Inspection, Payment and Acceptance	
14.1	Substantial Completion	49
14.2	Partial Utilization	49-50
14.3	Final Clean-Up	50
14.4	Final Inspection	50
14.5	Final Application for Payment	51
14.6	Final Payment and Acceptance	51
14.7	Payment of Retainage without Final Completion	51
14.8	Contractor's Continuing Obligation	52
14.9	Waiver of Claims	52
Article 15	Suspension of Work and Termination	
15.1	City May Suspend Work	53
15.2	City May Terminate	53-54
15.3	Contractor May Stop Work or Terminate	55

**ATTACHMENT B  
GENERAL CONDITIONS, PUBLIC UTILITIES**

**CITY OF HOLLYWOOD, FLORIDA  
GENERAL CONDITIONS  
FOR CONSTRUCTION CONTRACTS**

ARTICLE 1 - DEFINITIONS

In the interpretation of these Contract Documents the following terms shall have the meaning indicated:

**ADDENDA** - Written or graphic instruments issued prior to the opening of Bids which clarify, correct or change the Contract Documents.

**CHANGE ORDER** - A written order to CONTRACTOR executed in accordance with City procurement procedures, as amended authorizing an addition, deletion or revision in the work, or an adjustment in the Contract Price or the Contract Time, issued after the date of Award.

**CITY (OWNER)** - The City of Hollywood, Florida.

**COMMISSION** - The City Commission of the City of Hollywood, Florida, being the legislative body of the CITY as set forth in the City of Hollywood Charter.

**CONTRACT** - The written agreement between the CITY and the CONTRACTOR covering the work to be performed in accordance with the other Contract Documents which are attached to the Contract and made a part thereof.

**CONTRACTOR** - The person, firm, or corporation with whom the CITY has entered into the Contract.

**CONTRACT DOCUMENTS** - The Notice to Bidders, Instruction to Bidders, Proposal, Information Required of Bidders, all Bonds, Agreement, and all supporting documents, these General Requirements and Covenants, the Specifications, Drawings and Permits, together with all Addenda and Change Orders issued with respect thereto.

**CONTRACT PRICE** - Total monies payable by the CITY to the CONTRACTOR under the terms and conditions of the Contract Documents.

**CONTRACT TIME** - The number of days agreed to in the Proposal, commencing with the date of the Notice to Proceed for completion of the work.

**CONTROL** - shall mean having the primary power, direct or indirect, to influence the management of a business enterprise. The controlling party must have the demonstrable ability to make independent and unilateral business decisions on a day-to-day basis, as well as the independent and unilateral ability to make decisions which may influence and chart the future course of the business.

**DATE OF SUBSTANTIAL COMPLETION** - The date when the work on the project, or specified part thereof, is substantially completed in accordance with the Contract Documents, such that the

CITY can occupy or utilize the project or specified part thereof for the use and purpose for which it was intended as determined and accepted by the Engineer.

DAYS - Calendar days of 24 hours measured from midnight.

DRAWINGS - The drawings which show the character and scope of the work to be performed and which have been prepared by the DESIGN ENGINEER approved by ENGINEER and are referred to in and are a part of the Contract Documents.

ENGINEER - The Director of Public Utilities of the CITY of Hollywood, Florida, or his authorized designee.

EXCUSABLE DELAY - Delay caused by the CITY, hurricane, tornadoes, fires, floods, epidemics or labor strikes.

GENERAL CONDITIONS - That segment of the Contract Specifications incorporating the Provisions common to all CITY Construction Contracts.

INEXCUSABLE DELAY - Any delay caused either (i) by events or circumstances within the control of the CONTRACTOR not specified in the definition of excusable delay.

INSPECTOR - The authorized field representative of the ENGINEER.

LIQUIDATED DAMAGES - The amount prescribed in the General Requirements to be paid the CITY, or to be deducted from any payments due the CONTRACTOR for each day's delay in completing the whole or any specified portion of the work beyond the Contract Time.

NOTICE OF AWARD - The written notice by the CITY to the successful Bidder stating that upon his execution of the Agreement and other requirements as listed therein within the time specified the CITY will sign and deliver the Agreement.

NOTICE TO PROCEED - A written notice by the ENGINEER to the CONTRACTOR fixing the date on which the Contract Time will commence to run and on which the CONTRACTOR shall start to perform his obligation under the Contract Documents.

"OR EQUAL" - Equivalent or superior in construction, efficiency and effectiveness to a type, brand, model or process called out in the Contract Documents to establish a basis of quality as determined by the ENGINEER.

SHOP DRAWINGS - All certified affidavits, drawings, diagrams, illustrations, schedules and other data which are specifically prepared by CONTRACTOR, a Subcontractor, manufacturer, fabricator, supplier or distributor to illustrate some portion of the work and all illustrations, brochures, standard schedules, performance charts, instructions, diagrams and other information prepared by a manufacturer, fabricator, supplier or distributor and submitted by CONTRACTOR to illustrate material or equipment for some portion of the WORK.

SPECIFICATIONS - Division 1 through 17 of these Contract Documents, consisting of administrative details and written technical descriptions of materials, equipment, standards and workmanship.

SUPPLEMENTARY CONDITIONS - Division 1 of the Contract Specifications incorporating the provisions peculiar to a specific project.

SUBCONTRACTOR - An individual, firm or corporation having a direct contract with CONTRACTOR or with any other Subcontractor for the performance of a part of the work

SURETY - The person, firm or corporation responsible for the Bidder's acts in the execution of the Contract, or which is bound to the CITY with and for the CONTRACTOR to insure performance of the Contract and payment of all obligations pertaining to the work.

WORK - All the work materials or products specified, indicated, shown or contemplated in the Contract Documents to construct and complete the improvement, including all alterations, modifications, amendments or extension thereto made by Change Orders.

## ARTICLE 2 - ORGANIZATIONAL ABBREVIATIONS

Abbreviations of organizations which may be used in these Specifications are:

AASHTO:	American Association of State Highway and Transportation Officials
ACI:	American Concrete Institute
AIA:	American Institute of Architects
AISC:	American Institute of Steel Construction
AITC:	American Institute of Timber Construction
ANSI:	American National Standards Institute
APWA:	American Public Works Association
ASTM:	American Society for Testing and Materials
ASCE:	American Society of Civil Engineers
ASME:	American Society of Mechanical Engineers
ASHRAE:	American Society of Heating, Refrigerating and Air Conditioning Engineers
AWPA:	American Wood Preservers Association
AWWA:	American Water Works Association
AWS:	American Welding Society
BCEQCB:	Broward County Environmental Quality Control Board
CRSI:	Concrete Reinforcing Steel Institute
FDEP:	Florida Department of Environmental Protection
FDNR:	Florida Department of Natural Resources
FDOT:	Florida Department of Transportation
FPL:	Florida Power and Light
IEEE:	Institute of Electrical and Electronic Engineers
NACE:	National Association of Corrosion Engineers
NCPI:	National Clay Pipe Institute

NEC: National Electrical Code

NEMA: National Electrical Manufacturers Association

NFPA: National Fire Protection Association

OSHA: Occupational Safety and Health Act

PCI: Prestressed Concrete Institute

SFBC: South Florida Building Code, Broward Edition, Latest Revision

SFWMD: South Florida Water Management District

SSPC: Structural Steel Painting Council

UL: Underwriters' Laboratories, Inc.

UNCLE: Utility Notification Center for Location before Excavation (1-800-432-4770)

USEPA: United States Environmental Protection Agency

USGS: United States Geological Survey

WWEMA: Water and Wastewater Equipment Manufacturers Association

## ARTICLE 3 - MISCELLANEOUS PRELIMINARY MATTERS

### 3.1 Contract Document Discrepancies:

Any discrepancies, conflicts, errors or omissions found in the Contract Documents shall be promptly reported to the ENGINEER who will issue a correction, if necessary, in writing. The CONTRACTOR shall comply with any corrective measures regarding the same as prescribed by the ENGINEER.

### 3.2 Submissions:

Unless indicated otherwise in the Contract Documents, within seven days subsequent to the CONTRACTOR executing and submitting the required documents of Article 2.13 in Section II - Special Terms and Conditions, the CONTRACTOR shall submit to the ENGINEER an estimated progress schedule indicating the starting and completion days of the various stages of the work. A preliminary Schedule of Values and a preliminary schedule of Shop Drawing submissions may also be required by Section 01300 of Division 1 - General Requirements.

### 3.3 Pre-construction Conference:

The Contractor will be required to attend a mandatory Pre- Construction Conference for review of the above schedules, establishing procedures and establishing a working understanding among the parties as to the work.

### 3.4 Contract Time:

The Contract Time will commence on the date of the Notice to Proceed and shall exist for the total number of days as specified in Attachment C – Supplementary General Conditions, Section 1, Project Schedule as modified by any subsequent Change Orders, Unless the CONTRACTOR fails to complete the requirements of Section II - Special Terms and Conditions, the additional time in days (including weekends) required to correctly complete the documents will be deducted by CITY from the Contract Time specified by the CONTRACTOR in this Proposal.

### 3.5 Computation of Time:

When any period of time is referred to the Contract Documents by days, it shall be computed to exclude the first and include the last day of such period. If the last day of any such period falls on a Saturday or Sunday or on a legal holiday, such day shall be omitted from the computation.

### 3.6 Commencement of Work:

The CONTRACTOR shall not perform work at the site prior to the date of the Notice to Proceed.

### 3.7 Extension of Contract Time:

Extensions of time shall be based solely upon the effect of delays to the work as a whole. Extensions of time shall not be granted for delays to the work, unless the CONTRACTOR can clearly demonstrate, through schedule analysis, that the delay to the work as a whole arose in accordance with Article 11, Changes in Contract Time and that such delays did or will, in fact, delay the progress of work as a whole. Time extensions shall not be allowed for delays to parts of the work that are not on the critical path of the Project schedule. Time extensions shall not be granted until all float or contingency time, at the time of the delay, available to absorb specific delays and associated impacts, is used.

3.8    Notice and Service Thereof:

All notices, demands, requests, instructions, approvals and claims shall be in writing. Notices, demands, etc. shall be deemed to have been validly given if delivered in person to the individual or to a member of the firm or to an officer of the corporation for whom it is intended, or if delivered at or sent by registered or certified mail, postage prepaid, to the business address as defined at the Pre-Construction Conference.

3.9    Separate Contract:

The CITY reserves the right to let other Contracts in connection with this Project. The CONTRACTOR shall afford other Contractors reasonable opportunity for the introduction and storage for their materials and the execution of their work and shall properly connect and coordinate his work with theirs.

3.10    Assignments of Contract:

No assignment by the CONTRACTOR of the Contract or of any part thereof, or any monies due or to become due thereunder shall be made.

3.11    Patents:

It is mutually understood and agreed that without exception, Contract prices are to include all royalties and costs arising from patents, trademarks, and copyrights in any way involved in the work. It is the intent that whenever the Contractor is required or desired to use any design, device, material or process covered by letters, patent, or copyright, the right for such use shall be provided for by suitable legal agreements with the Patentee or Owner and a copy of this agreement shall be filed with the ENGINEER. However, whether or not such an agreement is made or filed as noted, the CONTRACTOR and the Surety in all cases shall indemnify and save harmless the CITY from any and all claims for infringement by reason of the use of any such patented design, device, material or process, to be performed under the Contract, and shall indemnify the said CITY from any costs, expenses, and damages which it may be obliged to pay, by reason of such infringement, at any time during the prosecution or after the completion of the work.

3.12    Federal Excise Tax:



The forms needed for applying for exemption certificates for materials and equipment, normally subject to the Federal Excise Tax, may be obtained from the Director of Internal Revenue, Jacksonville, Florida.

The CONTRACTOR is solely responsible for obtaining the desired exemption certificate from the Federal Government.

### 3.13 Savings Due to Excise Tax Exemptions:

The Bidder shall include in the Bid price the estimated cost of all goods, supplies and equipment which will be incorporated in the Work and the taxes that the Bidder would be required to pay if the Bidder were to purchase such goods, supplies or equipment. By subsequent Change Order(s), the parties shall reduce the Bid price to reflect any goods, supplies and equipment purchased directly by City and the resulting tax savings due to City's exemption from Excise Taxes.

CONTRACTOR shall pay all sales, consumer, use and other similar taxes required to be paid by CONTRACTOR in accordance with the laws and regulations of the State of Florida and its political subdivisions. Consistent with the tax exemption for municipalities provided by state law, CITY and CONTRACTOR shall jointly operate so that CITY may purchase directly, goods, supplies and equipment which will be incorporated into the Work. The goods, supplies and equipment that will be purchased by CITY shall be approved in advance by the parties.

With respect to all goods, supplies and equipment to be purchased by CITY, CONTRACTOR shall, on behalf of CITY, take all actions necessary and appropriate to cause all purchases to be made and shall be responsible for delivery of all such goods, supplies and equipment, including verification of correct quantities and documents or orders, coordination of purchases and delivery schedules, sequence of delivery, unloading, handling and storage through installation, obtaining warranties and guarantees required by the Contract Documents, inspection and acceptance of the goods, supplies and equipment at the time of delivery, and other arrangements normally required for the particular goods, supplies or equipment purchased. Unless otherwise directed by CITY, such actions shall also include taking the lead in efforts to resolve any and all disputes with the vendor. CONTRACTOR shall ensure that each vendor of goods, supplies and equipment purchased by CITY agrees in writing to the terms and conditions contained in CITY'S standard purchase order, which terms and conditions are set forth in Attachment C - Supplementary General Conditions of the Contract Documents. Even though CITY may purchase such goods, supplies and equipment, the goods, supplies and equipment shall be stored at the site in the same manner as goods, supplies and equipment purchased by CONTRACTOR.

CONTRACTOR shall hold CITY harmless from delays in manufacturing, delivery, and other unforeseen conditions that may arise as part of the procurement of CITY-purchased goods, supplies and equipment.

### 3.14 Overtime Work:

The CONTRACTOR shall receive no additional compensation for overtime work, i.e., work in excess of eight hours in any one calendar day or 40 hours in any one calendar week, even though such overtime work may be required under emergency conditions and may be ordered by the ENGINEER in writing. Additional compensation will be paid the CONTRACTOR for overtime work only in the event extra work is ordered by the ENGINEER and the Change Order specifically authorizes the use of overtime work and then only to such extent as overtime wages are regularly being paid by the CONTRACTOR for overtime work of a similar nature in the same locality.

### 3.15 Inspections and Testing during Overtime:

The CONTRACTOR shall establish a normal work schedule which does not exceed eight hours per day in a normal work day nor 40 hours per week in a normal work week. Normal work days shall be Monday through Friday. Whenever CONTRACTOR's work requires scheduled overtime, unless such overtime work is specifically required by the Contract Documents, CONTRACTOR shall reimburse the CITY for the extra costs incurred for providing Inspectors. Overtime shall be scheduled only after CONTRACTOR obtains written permission from the CITY. A change order shall be prepared to cover the CITY costs. Inspector costs shall be charged to the CONTRACTOR at a rate of \$80.00 per hour with a minimum of four hours charged for weekends and holidays. If the CONTRACTOR has an overtime work force size of fifty or more persons a second Inspector will be required and the costs for two Inspectors will be \$160.00 per hour.

### 3.16 Nights, Sunday or Holiday Work:

Except upon specific permission of the ENGINEER, the CONTRACTOR shall not perform any work on Sundays or on legal State or Municipal holidays. In accordance with City of Hollywood Code of Ordinances, Section 21.49, no work between 6:00 p.m. and 8:00 a.m. will be permitted, except in case of an emergency, that violates Section 21.49 concerning noise levels. All costs of testing and inspection performed during night, Sunday or holiday work shall be borne by the CONTRACTOR. The CONTRACTOR shall notify all regulatory agencies, including but not limited to the City Police Department, Fire Department, and Code Enforcement Department.

### 3.17 Injury or Damage Claims:

Should CITY or CONTRACTOR suffer injury or damage to their person or property because of any error, omission or act of the other party or of any of the other party's employees or agents or others for whose acts the other party is legally liable, claim shall be made in writing to the other party within a reasonable time of the first observance of such injury or damage. However, nothing herein shall be deemed to affect the rights, privileges and immunities of City as are set forth in Section 768.28, Florida Statutes.

## ARTICLE 4 - CONTRACT DOCUMENTS

### 4.1 Intent:

The Contract Documents comprise the entire Agreement between the CITY and CONTRACTOR concerning the work. The Contract Documents can be altered only by Change Order. The Contract Documents are complementary; what is called for by one is as binding as if called for by all. It is the intent of the Contract Documents that the CONTRACTOR, for due consideration, shall furnish all equipment, material, supervision and labor, (except as may be specifically noted otherwise) required or necessary to complete the work in total accordance with said Documents. It is the intent of the Drawings and Specifications to describe the Project to be constructed in accordance with the Contract Documents. Any work that may reasonably be inferred from the Drawings or Specifications as being required in order to produce the intended result shall be supplied whether or not it is specifically called for.

### 4.2 Order of Precedence of Contract Documents:

In resolving differences resulting from conflicts, errors or discrepancies in any of the following Contract Documents, the order of precedence shall be as follows:

1. Permits
2. Change Orders
3. Contract Agreement
4. Specification
5. Drawings

Within the Specifications the order of precedence is as follows:

1. Addenda
2. Section I - Introduction
3. Section II – Special Terms and Conditions
4. General Terms & Conditions
5. Attachment C- Supplementary General Conditions
6. Attachment B - General Conditions
7. Division 1, General Requirements
8. Technical Specifications
9. Referenced Standard Specifications

With reference to the Drawings the order of precedence is as follows:

1. Figures Govern over Scaled Dimensions
2. Detail Drawings Govern over General Drawings
3. Change Order Drawings Govern over Contract Drawings
4. Contract Drawings Govern over Standard or Shop Drawings

### 4.3 Reference To Standards:

Any reference to standard Specifications, manuals or codes of any organization or governmental authority shall mean the latest edition, in effect as of the Bid Opening Date.

## ARTICLE 5 - BONDS AND INSURANCE

### 5.1 Bid Guarantee:

Bidders maybe required to submit a Bid Guarantee in an amount indicated in the SECTION II - SPECIAL TERMS AND CONDITIONS. This Guarantee may be a Certified or Cashier's Check on a solvent National or State Bank, or a Bid Bond written by a Surety licensed to do business in Florida and rated at least "A", Class X in the latest edition of "Best's Key Rating Guide" published by A.M. Best Company.

### 5.2 Performance and Payment Bond:

CONTRACTOR shall furnish Performance and Payment Bonds, in amounts equal to the Contract Price as Security for the faithful performance and payment of CONTRACTOR's obligations. The Bond or Bonds shall remain in effect one year after the date of final payment. The Surety must be qualified as specified above in Paragraph 5.1. However, the City reserves the right to require additional bonds as set forth in Article 5 of the Contract.

### 5.3 Signatures:

All Bonds signed by an Agent must be accompanied by a Certified copy of the authority to act, with said copy having been signed (not typed nor printed) by an Officer of the Surety and carrying the seal of the Surety.

### 5.4 Insurance Coverage:

Within ten days from Notice of Award the CONTRACTOR shall purchase and maintain such insurance as specified in Article 2.25 of Section II – Special Terms and Requirements as will protect him from claims set forth below which may arise out of or result from the CONTRACTOR's operations under the Contract or Contract Documents, whether such operations be by himself or by any Subcontractor or by anyone directly or indirectly employed by any of them, or by anyone for whose acts any of them may be liable.

### 5.5 Certificates of Insurance:

Within ten days of award, the Contractor shall obtain a Certificate of Insurance reflecting the necessary coverages as required by the Contract Documents. Certificates of Insurance shall contain a provision that coverages afforded under the policies will not be canceled until at least 30 days prior written notice has been given to the CITY. The City of Hollywood must be named as additional insured on all coverage with the exception of Workmen's Compensation. Policies shall be issued by companies authorized to do business under the Laws of the State of Florida. Policyholders and Financial Ratings must be no less than "A" and Class X respectively in the latest edition of "Best Key Rating Guide", published by A.M. Best Company.

5.6 Insurance Limits of Liability:

The insurance required by this Article shall be written for no less than the level of liability specified in "Insurance Requirements", Section 2 of the Supplementary General Conditions, or required by law, whichever is greater. The insurance shall include contractual liability insurance applicable to the CONTRACTOR's obligations under this contract.

The level required in Section 2 of the Supplementary General Conditions will not be reduced for any reason.

## ARTICLE 6 - AVAILABILITY OF LAND; REFERENCE POINTS

### 6.1 Rights-of-Way:

Lands or Rights-of-Way for the work to be constructed under the Contract will be provided by the CITY. Nothing contained in the Contract Documents shall be interpreted as giving the CONTRACTOR exclusive occupancy of the lands or Rights-of-Way provided. Any additional lands or Rights-of-Way required for construction operations shall be provided by the CONTRACTOR at his own expense; provided, that the CONTRACTOR shall not; and the CITY nor the ENGINEER shall not be liable for any claims or damages resulting from the CONTRACTOR's unauthorized trespass or use of any such properties.

### 6.2 Permits:

When required by Article 2.16 of the Section II – Special Terms and Conditions, the CONTRACTOR shall secure, from the agencies having jurisdiction, the necessary permits to create obstructions, to make excavations if required under the Contract, and to otherwise encroach upon Rights-of-Way, and to present evidence to the ENGINEER that such permission has been granted, before work is commenced. Regulations and requirements of all agencies concerned shall be strictly adhered to in the performance of the Contract. The enforcement of such requirements under the Contract shall not be made the basis for additional compensation.

### 6.3 Lines and Grades:

The CONTRACTOR shall furnish all grades and all other lines required for the proper execution of the work.

## ARTICLE 7 - CONTRACTOR'S RESPONSIBILITIES

### 7.1 Laws/Regulations to Be Observed:

The CONTRACTOR shall familiarize himself and comply with all Federal, State, County and CITY laws, by-laws, ordinances or regulations controlling the action or operation of those engaged or employed in the work or affecting material used, and govern himself in accordance with them. He shall indemnify and save harmless the CITY and all of its officers, agents and employees against any claims or liability arising from or based on the violation of any such laws, by-laws, ordinances, regulations, orders or decrees, whether by himself or his employees or Subcontractors.

### 7.2 Indemnification of City:

- (a) Refer to ARTICLE 1.46 – INDEMNIFICATION AND HOLD HARMLESS AGREEMENT of Section IV – General Terms and Conditions.
- (b) Refer to ARTICLE 1.47 – PATENT AND COPYRIGHT INDEMNIFICATION of Section IV – General Terms and Conditions.
- (c) The provisions of (a) and (b) above shall survive the expiration or earlier termination of the Contract Documents.

### 7.3 Guarantee of Payments:

The CONTRACTOR guarantees the payments of all just claims for materials, supplies, tools, labor and other just claims against him, or any Subcontractor in connection with this Contract, and his bond will not be released by final acceptance and payment by the CITY unless all such claims are paid or released.

### 7.4 Permits and Licenses:

The CONTRACTOR shall obtain all permits and licenses required by the Contract Documents. A copy of the permit(s) and such conditions and requirements thereon are a part of the Contract Documents. Failure to obtain such permits or licenses shall subject the CONTRACTOR to the provisions of the South Florida Building Code, Broward Edition.

## 7.5    Emergencies:

In emergencies affecting the safety or protection of persons or the work or property at the site or adjacent thereto, CONTRACTOR, without special instruction or authorization from ENGINEER or CITY, is obligated to act to prevent threatened damage, injury or loss. CONTRACTOR shall give ENGINEER prompt written notice of any significant changes in the work or deviations from the Contract Documents caused thereby.

## 7.6    Substitutes or "Or Equal":

### A.      Substitutes or "Or-Equal" Materials or Equipment:

Whenever materials or equipment are specified or described in the Contract Documents by using the name of a proprietary item or the name of a particular supplier the naming of the item is intended to establish the type, function and quality required. Unless the name is followed by words indicating that no substitution is permitted, materials or equipment of other Suppliers may be accepted by the ENGINEER if sufficient information submitted by the CONTRACTOR to allow the ENGINEER to determine that the material or equipment proposed is equivalent or equal to that named. The ENGINEER will be allowed 30 days within which to evaluate each proposed substitute. The ENGINEER will be the sole judge of acceptability, and NO SUBSTITUTE WILL BE ORDERED, INSTALLED OR UTILIZED WITHOUT THE ENGINEER'S PRIOR WRITTEN ACCEPTANCE which will be evidenced by either a Change Order or an approved set of Shop Drawings. Requests for review of substitute items of material and equipment will not be accepted by the ENGINEER from anyone other than the CONTRACTOR. The procedure for review by the ENGINEER is as follows:

If the CONTRACTOR wishes to furnish or use a substitute item of material or equipment, the CONTRACTOR shall make written application to the ENGINEER for acceptance thereof, certifying that the proposed substitute will perform adequately the functions and achieve the results called for by the general design, be similar and of equal substance to that specified and be suited to the same use as that specified. In addition, the application shall

1. State that the evaluation and acceptance of the proposed substitute will not prejudice the CONTRACTOR's achievement of completion on time.
2. State whether or not acceptance of the substitute for use in the WORK will require a change in any of the Contract Documents to adapt design to the proposed substitute. The CONTRACTOR shall be responsible for any extra design adaptation costs associated with a proposed substitute.
3. State whether or not incorporation or use of the substitute in connection with the work is subject to payment of any license fee or royalty.
4. Provide complete substitute identification and description, including manufacturer's and local distributor's name and address, performance and test data, and reference standards.



5. Provide samples, as required by ENGINEER.
6. Provide name and address of similar projects on which the proposed substitute has been used, and date of installation.
7. Identify all variations of the proposed substitute from that specified.
8. Indicate available maintenance, repair and replacement service.
9. Submit an itemized estimate of all costs that will result directly or indirectly from acceptance of such substitute, including costs of redesign and claims of other Contractors affected by the resulting change. The CONTRACTOR shall be responsible for the costs of redesign and claims of other Contractors.
10. Provide any additional data about the proposed substitute as the ENGINEER may require of the CONTRACTOR.

B. Substitute means, method, technique, sequence or procedure of construction:

If a specific means, method, technique, sequence or procedure of construction is indicated in or required by the Contract Documents, the CONTRACTOR may furnish or utilize a substitute means, method, sequence, technique or procedure of construction acceptable to the ENGINEER, if the CONTRACTOR submits sufficient information to allow the ENGINEER to determine that the substitute proposed is equivalent to that indicated or required by the Contract Documents. The procedure for review by the ENGINEER will be similar to that provided in Paragraph 7.6 A.

- C. The CITY may require the CONTRACTOR to furnish at the CONTRACTOR's expense, a special performance guarantee or other surety with respect to any substitute.
- D. The ENGINEER will record time required by the ENGINEER and/or the ENGINEER's consultants in evaluating substitutions proposed by the CONTRACTOR and in making changes in the Contract Documents occasioned thereby. Whether or not the ENGINEER accepts a proposed substitute, THE CONTRACTOR SHALL REIMBURSE THE CITY FOR THE CHARGES OF THE ENGINEER AND THE ENGINEER'S CONSULTANTS FOR EVALUATING EACH PROPOSED SUBSTITUTE.
- E. Any and all costs which result from changes to/adaptations of the work shall be paid by the CONTRACTOR including but limited to design, materials, installation, etc.

## 7.7 Shop Drawings:

Shop Drawing submittals shall be as follows:

- A. The CONTRACTOR shall submit a sufficient number of copies of each Shop Drawing to enable the ENGINEER to retain three copies unless additional copies are specified in the Contract Documents. Resubmissions of Shop Drawings shall be made in the same quantity until final approval is obtained.
- B. The CONTRACTOR shall submit Shop Drawings for all equipment, apparatus, machinery, fixtures, piping, fabricated structures, manufactured articles and structural components Manufacturer's Certified Affidavit that the item supplied complies with the design Specifications, and all other submittal requirements.
- C. Shop Drawings for structural components, electrical or mechanical systems shall be Certified by a Registered Engineer of the discipline involved.
- D. The CONTRACTOR shall thoroughly review and check the Shop Drawings, and each and every copy shall show his approval thereon. If the Shop Drawings show or indicate departures from the Contract requirements, the CONTRACTOR shall make specific mention thereof in his letter of transmittal. Failure to point out such departures shall not relieve the CONTRACTOR from his responsibility to comply with the Drawings and Specifications.
- E. No approval will be given to partial submittals of Shop Drawings for items which interconnect and/or are interdependent. It is the CONTRACTOR's responsibility to assemble the Shop Drawings for all such interconnecting and/or interdependent items, check them himself and then make one submittal to the ENGINEER along with his comments as to compliance, non-compliance, or features requiring special attention.
- F. If catalog sheets or prints of manufacturer's standard drawings are submitted as Shop Drawings, any additional information or changes on such Drawings shall be typewritten or lettered in ink.
- G. The CONTRACTOR shall keep one set of Shop Drawings marked with the ENGINEER's approval at the job site at all times.
- H. Where a Shop Drawing or sample is required by the Specifications, no related work shall be commenced until the submittal has been reviewed and approved by the ENGINEER.
- I. Approval of the Shop Drawings shall constitute approval of the subject matter thereof only, and not of any structure, material, equipment or apparatus shown or indicated. The approval of the Shop Drawings will be general and shall not relieve the CONTRACTOR of responsibility for the accuracy of such Drawings, nor for the proper fitting and construction of the work, nor for the furnishing of materials or work required by the contract and not indicated on the Drawings. Approval shall not relieve the CONTRACTOR from responsibility for errors or omissions of any sort on the Shop Drawings.

## 7.8

### Personnel:

#### A. Supervision and Superintendence:

1. The CONTRACTOR shall supervise and direct the work competently and efficiently, devoting such attention thereto and applying such skills and expertise as may be necessary to perform the work in accordance with the Contract Documents. The CONTRACTOR shall be solely responsible for the means, methods, techniques, sequences and procedures of construction, but the CONTRACTOR shall not be solely responsible for the negligence of others in the design or selection of a specific means, method, technique, sequence or procedure of construction which is indicated in and required by the Contract Documents. The CONTRACTOR shall be responsible to see that the finished work complies accurately with the Contract Documents.
2. The CONTRACTOR shall keep on the work at all times during its progress a competent resident Superintendent fluent in both oral and written communication in the English language, who shall not be replaced without written notice to the ENGINEER except under extraordinary circumstances. The Superintendent will be the CONTRACTOR's representative at the site and shall have authority to act on behalf of the CONTRACTOR. All communications given to the Superintendent shall be as binding as if given to the CONTRACTOR.

#### B. Workforce:

1. None but skilled workers shall be employed on work requiring special qualifications. When required in writing by the ENGINEER, the CONTRACTOR or any Subcontractor shall discharge any person who is, in the opinion of the ENGINEER, incompetent, disorderly or otherwise unsatisfactory, and shall not again employ such discharged person on the work except with the consent of the ENGINEER. Such discharge shall not be the basis of any claim for damages against the CITY or any CITY agents.
2. With respect to all skilled, semi-skilled and unskilled workers employed on the Project under this Contract, preference in employment shall be given to persons residing in Hollywood when such persons are available and qualified to perform the work to which the employment relates. No person shall be employed in violation of the State or National Labor Laws. No person under the age of 16 years shall be employed on a Project under the Contract. No person whose age or physical condition is such as to make his employment dangerous to his health or safety or to the health or safety of others shall be employed on the Project under this Contract; provided that this shall not operate against the employment of physically handicapped persons, otherwise employable where such persons may be safely assigned to work which they can ably perform. No person currently serving sentences in a penal or correctional institution and no inmate of an institution for mentally defective shall be employed on a Project under this Contract without specific approval of the ENGINEER.

3. No discrimination shall be made in the employment of persons on the work by the CONTRACTOR or by any Subcontractor under him, because of the race, color, sex, age or religion of such persons, and there shall be full compliance with the provisions of applicable State and Federal laws in this regard.

## 7.9 Safety and Protection:

### A. Federal Safety and Health Regulations:

The CONTRACTOR and Subcontractors shall comply with the provisions of the Occupational Safety and Health Standards, promulgated by the Secretary of Labor under the "Occupational Safety and Health Act of 1970".

### B. Responsibilities:

The CONTRACTOR shall be responsible for initiating, maintaining and supervising all safety precautions and programs in connection with the work. The CONTRACTOR shall take all necessary precautions for the safety of, and shall provide the necessary protection to prevent damage, injury or loss to:

1. All employees on the work and other persons who may be affected thereby.
2. All the work and all materials or equipment to be incorporated therein, whether in storage on or off the site.
3. Other property at the site or adjacent thereto, including trees, shrubs, lawns, walks, pavements, roadways, structures and utilities not designated for removal, relocating or replacement in the course of construction.

### C. Designated Safety Officer:

The CONTRACTOR shall designate a responsible member of his organization at the site whose duty shall be the prevention of accidents. This person shall be the CONTRACTOR's Superintendent unless otherwise designated in writing by the CONTRACTOR to the ENGINEER.

### D. Protection of the Work:

Until acceptance of the work by the CITY, it shall be under the charge and in care of the CONTRACTOR and he shall take every necessary precaution against injury or damage to the work by action of the elements or from the execution or from the non-execution of the work. The CONTRACTOR shall rebuild, restore and make good, at his own expense, all injuries or damages to any portion of the work occasioned by any of the above causes before its completion and acceptance.

7.10 Traffic Control, Public Safety and Convenience:

- A. The CONTRACTOR shall at all times conduct his work so as to assure the least possible obstruction to traffic and inconvenience to the general public, and provide adequate protection of persons and property in the vicinity of the work.
- B. WHEN THE NORMAL FLOW OF TRAFFIC WILL BE IMPAIRED OR DISRUPTED IN ANY MANNER ON ANY STREET, THE CONTRACTOR SHALL NOTIFY THE POLICE TRAFFIC SERGEANT AT 921-3610 AT LEAST 48 HOURS IN ADVANCE.
- C. Streets shall not be closed, except when and where directed by the ENGINEER, and whenever a street is not closed the work must be conducted with the provision for safe passageway for traffic at all times. The CONTRACTOR shall make all necessary arrangements concerning maintenance of traffic and selection of detours required.
- D. When permission has been granted to close an existing roadway, or portion thereof, the CONTRACTOR shall furnish and erect signs, barricades, lights, flags and other protective devices as necessary subject to the approval of the ENGINEER. From sunset to sunrise, the CONTRACTOR shall furnish and maintain as many yellow lights as the ENGINEER may direct.
- E. During working hours the CONTRACTOR shall furnish watchmen in sufficient numbers to protect and divert the vehicular and pedestrian traffic from working areas closed to traffic, or to protect any new work. Failure to comply with this requirement will result in the ENGINEER shutting down the work until the CONTRACTOR shall have provided the necessary protection.
- F. No separate payment will be made for such signs, barricades, lights, flags, watchmen or other protective devices as required, with all costs thereof deemed to be included in the prices bid for the various items scheduled in the bid.
- G. Sidewalks, gutters, drains, fire hydrants and private drives shall, in so far as practicable, be kept in condition for their intended uses. While the work is actually going on at any location, as much as half the street width at that location may be barricaded to exclude traffic entirely, but street traffic shall not be obstructed needlessly. Fire hydrants on or adjacent to the work shall be kept accessible to fire apparatus at all times, and no material or obstruction shall be placed within ten feet of any such hydrant.
- H. Construction material stored upon the public street shall be placed so as to cause as little obstruction to the general public as is reasonably possible.

#### 7.11 Use of Explosives:

When the use of explosives is necessary for the prosecution of the work, the CONTRACTOR shall observe the utmost care so as not to endanger life or property, and whenever directed, the number and size of charges shall be limited. All explosives shall be stored in a secure manner and all such storage places shall be marked clearly "DANGEROUS EXPLOSIVES" and shall be in care of a competent watchman at all times. The CONTRACTOR must familiarize himself with all laws and ordinances pertaining thereto, and govern himself and his employees accordingly.

#### 7.12 Loading of Structures:

The CONTRACTOR shall not load nor permit any part of any structure to be loaded in any manner that will endanger the structure, nor shall the CONTRACTOR subject any part of the work or adjacent property to stresses or pressures that will endanger it.

#### 7.13 Concerning Subcontractors:

- A. The CONTRACTOR, with his own forces, shall perform no less than 25% of the work as determined by the Contract price. Each Subcontractor shall be properly licensed for the type of work he is to perform.
- B. A copy of each Sub-Contract shall be filed promptly with the ENGINEER upon request. Each Sub-Contract shall contain a reference to the Contract between the CITY and the CONTRACTOR, and the terms and conditions of the Contract shall be made a part of each Sub-Contract. Each Sub-Contract shall provide for annulment of same by the CONTRACTOR upon written order of the ENGINEER if the Subcontractor fails to comply with the requirements of this Contract.
- C. The CONTRACTOR shall be responsible to the CITY and ENGINEER for the acts and omissions of his Sub-Contractors and their employees to the same extent as he is responsible for the acts and omissions of his own employees. Nothing contained in this Contract shall create any contractual relationship between any Subcontractor and the CITY or ENGINEER nor relieve the CONTRACTOR of any liability or obligation under this Contract.

#### 7.14 Materials and Equipment:

- A. Material for the Work:
  - 1. The CONTRACTOR shall furnish all materials, equipment, labor, transportation, construction equipment and machinery, tools, appliances, fuel, power, light, heat, telephone, water and sanitary facilities and all other facilities and incidentals necessary for the execution, testing, initial operation and completion of the work.
  - 2. Unless otherwise specified, shown or permitted by the ENGINEER, all material and equipment incorporated in the work shall be new and of current manufacture. The ENGINEER may request the CONTRACTOR to furnish manufacturer's certificates to this effect.

3. The ENGINEER may require any or all materials to be subjected to test by means of samples or otherwise, at production points or after delivery. The CONTRACTOR shall afford such facilities as the ENGINEER may require for collecting and forwarding samples, which samples shall be furnished by the CONTRACTOR without charge. The CONTRACTOR shall furnish evidence satisfactory to the ENGINEER that the materials and finished articles have passed the required test prior to the incorporation of such materials and finished articles in the work. Unless otherwise provided, the cost of such inspection and testing shall be as provided in Article 12.2.
4. All packaged manufactured products for use on the work shall be delivered to the work in their original, unopened packages, bearing thereon the manufacturer's name and the brand name of the product.
5. Wherever any product or material is selected to be used on the work, all such products or material shall be of the same brand and manufacture throughout the work.
6. All equipment, tools and machinery used for handling material or executing any part of the work shall be maintained in a satisfactory working condition. All equipment utilized on any portion of the work shall be such that no injury to personnel, the work, adjacent property or other objects will result from its use.
7. All materials and equipment shall be applied, installed, connected, erected, used, cleaned and conditioned in accordance with the instructions of the applicable manufacturer, fabricator, supplier or distributor, except as otherwise provided in the Contract Documents.

B. Storage of Materials:

1. All materials and equipment including that ordered by the CITY designed for permanent installation in the work shall be properly stored by the CONTRACTOR to insure protection against deterioration of any type. These materials shall be placed as to cause a minimum of inconvenience to other contractors on the work and to the public. The storage piles shall be arranged to facilitate inspections, and any deterioration shall be grounds for rejection.
2. Materials stored in public Rights-of-Way, shall be stored in such a manner so as to be compatible with the Traffic Control requirements set forth in Paragraph 7.10. Materials shall be stored so as not to deny access to public or private property. Stored materials shall be adequately marked with barricades and/or flashing warning lights, where necessary, so as to protect the materials from damage and to protect the public health, safety and welfare.
3. Lawns, grass plots or other private property shall not be used for storage purposes without written permission of the Owner or Lessee of that private property. Should the CONTRACTOR desire to store equipment or materials of any kind on the property of the CITY, he must obtain permission from the

ENGINEER. The CITY reserves the right to order materials to be removed or relocated in such approved storage areas, if necessary.

4. The protection of stored materials shall be the CONTRACTOR's responsibility and the CITY OF HOLLYWOOD shall not be liable for any loss of materials, by theft or otherwise, nor for any damage to the stored materials.

C. **Salvage of Materials and Equipment:**

The CITY reserves the right to retain title to all soil, sand, stone, gravel, equipment, machinery or any other material that was a part of the structure, site or Right-of-Way and which was developed from excavations or other operations connected with the work. The CONTRACTOR will be permitted to use in the work, without charge, any such material which meets the requirements of the Contract Documents. For that material which the CITY desires to retain the CONTRACTOR shall, at his expense, transfer to a site within the CITY as designated by the ENGINEER. That material which the CITY does not wish to retain shall be the property of the CONTRACTOR and removed from the site at CONTRACTOR's expense.

**7.15 Temporary Utilities:**

The CONTRACTOR shall provide and maintain at his own expense, all water, power, telephone and sanitary facilities as required to comply with State and/or local Codes and Regulations. If water, including that for testing is required, it is the CONTRACTOR's responsibility to arrange through the CITY Water Department for a water meter. A deposit to be paid by the CONTRACTOR is required for meter rental and all water shall be purchased at the prevailing rate.

**7.16 Review of Records:**

The CONTRACTOR shall allow and permit the ENGINEER or his duly authorized representative to inspect and review all payrolls, records of personnel, conditions of employment, invoice of materials, books of accounts and other relevant data and records pertinent to the CONTRACT and Sub-Contracts.

**7.17 Use of Premises:**

CONTRACTOR shall confine construction equipment, the storage of materials and equipment and the operations of workmen to areas permitted by law, ordinances, permits or required by the Contract Documents, and shall not interfere with the premises or operation of the City Utilities facilities with construction equipment or other materials or equipment. Construction which interferes with Plant Operations shall be fully coordinated and approved by the ENGINEER.



7.18 CONTRACTOR's Daily Reports:

Except where otherwise provided, the CONTRACTOR shall complete a daily report indicating manpower, major equipment, Subcontractors, etc., involved in the performance of the work. The daily report shall be completed on forms approved by the ENGINEER, and shall be submitted to the ENGINEER at the conclusion of each work day.

7.19 Record Documents:

The CONTRACTOR shall keep one record copy of all Specifications, Drawings, Addenda, Modifications, Shop Drawings and samples at the site, in good order and annotated to show all changes made during the construction process. These shall be available to ENGINEER for examination and shall be delivered to ENGINEER upon completion of the work.

7.20 Cleanliness of the Site:

During the progress of the work, The CONTRACTOR shall keep the premises free from accumulations of waste materials, rubbish and other debris resulting from the work. At the completion of the work the CONTRACTOR shall remove all waste materials, rubbish and debris from and about the premises as well as all tools, appliances, construction equipment and machinery and surplus materials, and shall leave the site clean and ready for occupancy by the CITY. The CONTRACTOR shall restore to their original condition those portions of the site not designated for alteration by the Contract Documents.

7.21 Dust Control:

It shall be the CONTRACTOR's responsibility to control dust by watering as directed by the ENGINEER. The water used shall be paid for by the CONTRACTOR. Should the CONTRACTOR fail to control dust to the satisfaction of the ENGINEER, the CITY will control the dust by whatever means the CITY desires and the CONTRACTOR shall pay all expenses incurred by the CITY associated with the control of the dust.

7.22 Continuing the Work:

The CONTRACTOR shall carry on the work and maintain the Progress Schedule during all disputes or disagreements with the CITY. No work shall be delayed or postponed pending resolution of any disputes or disagreements, except as the CONTRACTOR and the CITY may otherwise agree in writing.

7.23 Indemnification:

In consideration of the amount listed in the Bid Form and other valuable consideration, the Contractor shall defend, indemnify and save harmless the CITY, its officers, agents, and employees from or on account of any personal injury, loss of life or damage to property received or sustained by any person or persons during or on account of any operations connected with the construction of this Project; or by or in consequence of any negligence (excluding negligence of the CITY), in connection with the same; or by use of any improper materials or by or on account of any use of any improper materials or by or on account of any act or omission of the said Contractor or his subcontractor, agents, servants or employees. Contractor agrees to indemnify and save harmless the CITY against any liability arising from or based upon the violation of any federal, state, county or city laws, by-laws, ordinances or regulations by the Contractor, his subcontractor, agents, servants

or employees. Contractor further agrees to indemnify and save harmless the CITY from all such claims and fees, and from any and all suits and actions of every name and description that may be brought against the CITY on account of any claims, fees, royalties, or costs for any invention or patent, and from any and all suits and actions that may be brought against the CITY for the infringement of any and all patents or patent rights claimed by any person, firm, or corporation.

The indemnification provided above shall obligate the Contractor to defend at his own expense or to provide for such defense, at the CITY's option, any and all claims or liability and all suits and actions of every name and description that may be brought against the Owner which may result from the operations and activities under this Contract whether the construction operations be performed by the Contractor, his subcontractor or by anyone directly or indirectly employed by either.

Nothing in this indemnification shall be deemed to affect the rights, privileges or immunities of the CITY as set forth in Section 768.28, Florida Statutes.

The CITY will pay to the Contractor the specific consideration, in the amount stated in the Bid Form. The Contractor shall acknowledge the receipt of payment and other good and valuable consideration from the Owner which has been paid to him as specific consideration for the indemnification provided herein and in accordance with the provisions of Chapter F.S.A., Section 725.06.

## ARTICLE 8 - CITY'S RESPONSIBILITIES

### 8.1 Communications:

The CITY shall issue all communications to the CONTRACTOR through the ENGINEER.

### 8.2 Furnish Contract Documents:

The CITY shall furnish the number of Contract Documents as specified in the Supplementary General Conditions to the CONTRACTOR at no cost. Referenced Standard Specifications Manuals, guidebooks, etc., will not be provided.

### 8.3 Furnish Right-of-Way:

The CITY shall furnish the necessary land or Right-of-Way on which the work is to be accomplished, and will provide lines and grades as specified in Article 6.

### 8.4 Timely Delivery of Materials:

The CITY shall be responsible for the delivery of any CITY furnished material, equipment or labor as specified in the Contract Documents.

## ARTICLE 9 - ENGINEER'S STATUS

### 9.1 Authority of the Engineer:

- A. The general supervision of the execution of this Contract is vested in the ENGINEER who is the CITY's sole representative during the construction period. The instructions of the ENGINEER are to be strictly and promptly followed in every case. The CONTRACTOR's representative (Article 7.8 A. 1.) shall be responsible for the execution of any instructions given by the ENGINEER during the absence of the CONTRACTOR.
- B. The ENGINEER is the initial interpreter of the requirements of the Contract Documents and judge of the acceptability of the work. Claims, disputes and other matters relating to the acceptability of work or requirements of the Contract Documents shall be referred in writing to the ENGINEER within 15 days of the event, with a request for a formal decision, which the ENGINEER will render in writing within a reasonable time. This rendering of a decision by the ENGINEER will be a condition precedent to any exercise by the CITY or CONTRACTOR of rights or remedies as either may otherwise have under the Contract Documents or at law in respect to any such claim, dispute or other matter.
- C. The ENGINEER will issue with reasonable promptness any written clarifications or interpretations of the Contract Documents as he shall deem necessary, which shall be consistent with or reasonably inferable from the overall intent of the Contract Documents. If, as a result of a clarification or interpretation, either the CONTRACTOR or ENGINEER believes a Change Order is justified, it shall be submitted.
- D. The ENGINEER has approval authority over the acceptability of all material or equipment furnished, Shop Drawings, Change Orders, work performed and the rate of progress of the work. Verification of the quantities of work performed for pay purposes is the responsibility of the ENGINEER.
- E. The ENGINEER also has the authority to disapprove or reject work which is defective, and may require special inspection or testing of the work, whether or not it is fabricated, installed or completed.
- F. The ENGINEER has the authority to suspend the work wholly or in part for such period or periods as may be deemed necessary, due to the unsuitable prosecution of the work, or for such time as is necessary due to failure on the part of the CONTRACTOR to carry out orders given or perform any or all provisions of the Contract. The CONTRACTOR shall not suspend the work and shall not remove any equipment, tools, lumber or other materials without the written permission of the ENGINEER.

## 9.2 Access to the Work:

The ENGINEER is to have free access to the materials and work at all times for laying out, measuring or inspecting same, and the CONTRACTOR is to afford him all necessary facilities and assistance for so doing.

## 9.3 Limitations on The ENGINEER's Responsibilities:

- A. Neither the ENGINEER's authority to act under this Article or elsewhere in the Contract Documents nor any decision made by the ENGINEER in good faith either to exercise or not exercise such authority shall give rise to any duty or responsibility of the ENGINEER to the CONTRACTOR, any Subcontractor, any manufacturer, fabricator, supplier or distributor or any of their agents or employees or any other person performing any of the work.
- B. Whenever in the Contract Documents the terms "as ordered", "as directed", "as required", "as allowed" or terms of like effect or import are used, or the adjectives "reasonable", "suitable", "acceptable", "proper" or "satisfactory" or adjectives of like effect or import are used, to describe requirement, direction, review or judgment of the ENGINEER as to the work, it is intended that such requirement, direction, review or judgment will be solely to evaluate the work for compliance with the Contract Documents (unless there is a specific statement indicating otherwise). The use of any such term or adjective never indicates that the ENGINEER has authority to supervise or direct performance of the work.
- C. The ENGINEER will not be responsible for the CONTRACTOR's means, methods, techniques, sequences or procedures of construction, nor the safety precautions and programs incident thereto, and the ENGINEER will not be responsible for the CONTRACTOR's failure to perform the work in accordance with the Contract Documents.
- D. The ENGINEER will not be responsible for the acts or omissions of the CONTRACTOR or of any Subcontractors, or of the agents or employees of any CONTRACTOR or subcontractor, or of any other persons at the site or otherwise performing any of the work.

## 9.4 Inspectors:

- A. Inspectors employed by the CITY assist the ENGINEER in ascertaining the work conforms to the Contract Documents and are authorized to inspect all work done and material furnished as representatives of the ENGINEER. Inspectors shall be stationed at the site of the work to report to the ENGINEER as to the progress of the work and the quality of workmanship and material.
- B. In case of any dispute arising between the CONTRACTOR and the Inspector, the Inspector shall have the authority to reject material or to suspend the work until the question of issue can be referred to and decided upon by the ENGINEER.
- C. If the CONTRACTOR refuses to suspend operation on verbal order, the Inspector shall issue a written order giving the reason for shutting down the work. After

placing the order in the hands of the man in charge, the Inspector shall immediately leave the job. work done during the absence of the Inspector, after such written notice, will not be accepted nor paid for.

- D. Inspectors are not authorized to revoke, alter, enlarge, relax or release any requirements of these Contract Documents, nor to issue instructions contrary to them. Inspectors shall in no case act as foreman or perform other duties for the CONTRACTOR, nor interfere with management of the work by the latter. Any instructions which Inspectors may give the CONTRACTOR shall in no way be construed as releasing the CONTRACTOR from fulfillment of the terms of the Contract.
- E. The payment of any compensation, whatever may be its character or form, or the giving of any gratuity, or the granting of any valuable favor, by the CONTRACTOR to any Inspector, directly or indirectly, is strictly prohibited and any such act on the part of the CONTRACTOR will constitute a violation of this Contract and may subject the CONTRACTOR to other penalties provided for by law or ordinance.

#### 9.5 Inspections:

- A. The ENGINEER will make, or have made, such inspections and tests as he deems necessary to assure that the work is being accomplished in accordance with the requirements of the Contract. In the event such Inspections or tests reveal non-compliance with the requirements of the Contract, the CONTRACTOR shall bear the cost of such corrective measures as well as the cost of subsequent reinspection and retesting.
- B. Work done in the absence of a prescribed inspection may be required to be removed and replaced under proper inspection. The entire cost of removal and replacement, including the cost of all material which may be furnished by the CITY and used in the work thus removed, shall be borne by the CONTRACTOR, regardless of whether the work removed is found to be defective or not. Work covered up without the authority of the ENGINEER, shall, upon order of the ENGINEER, be uncovered to the extent required, and the CONTRACTOR shall similarly bear the entire cost of performing all the work and furnishing all the material necessary for the removal of the covering and its subsequent replacement.
- C. Unless otherwise provided, the cost of inspection and all inspection fees imposed by public agencies other than the fees associated with the issuance of the Master Building Permit by the City of Hollywood shall be paid by the CONTRACTOR.
- D. No inspection nor any failure to inspect at any time or place shall relieve the CONTRACTOR from any obligation to perform all of the work in strict conformance with the requirements of the Contract Documents.

## ARTICLE 10 - CHANGES IN THE WORK/CONTRACT PRICE

### 10.1 Changes in the Work or Terms of Contract Documents:

- A. Without invalidating the Contract and without notice to any surety CITY reserves and shall have the right, from time to time to make such increases, decreases or other changes in the character or quantity of the Work as may be considered necessary or desirable to complete fully and acceptably the proposed construction in a satisfactory manner. Any extra or additional work within the scope of this Project must be accomplished by means of appropriate Clarifications, Field Orders, or Change Orders.
- B. Any changes to the terms of the Contract Documents must be contained in a written document, executed by the parties hereto, with the same formality and of equal dignity prior to the initiation of any work reflecting such change.

This section shall not prohibit the issuance of Change Orders executed only by CITY as hereinafter provided.

### 10.2 Supplemental Instructions - Clarifications:

- A. The CITY, through the ENGINEER, shall have the right to approve and issue Clarifications setting forth written interpretations of the intent of the Contract Documents and ordering minor changes in Work execution, providing the Clarifications involve no change in the Contract Price or the Contract Time.
- B. The ENGINEER shall have the right to approve and issue Clarifications setting forth written orders, instructions, or interpretations concerning the Contract Documents or its performance, provided such Clarifications involve no change in the Contract Price or the Contract Time.

### 10.3 Field Orders / Change Orders:

- A. Changes in the quantity or character of the Work within the scope of the Project which are not properly the subject of Clarifications, including all changes resulting in changes in the Contract Price or the Contract Time, shall be authorized only by Field Orders or Change Orders approved in advance and issued in accordance with the provisions of the CITY Procurement Code, as amended from time to time.
- B. CONTRACTOR shall not start work on any changes requiring an increase in the Contract Price or the Contract Time until a Field Order or Change Order setting forth the adjustments is approved by the CITY. Upon receipt of a Change Order CONTRACTOR shall promptly proceed with the work set forth within the document.

- C. Field Orders shall be issued for change in Contract Price related to Cost Allowances specifically included on the Proposal Bid Form. Change Orders shall be issued when required for all other Contract Price Changes. Hereinafter, the term "Change Order(s)" shall be used to include "Change Orders" and "Field Orders" with the exception that Field Order shall not be used for any Contract Time adjustments.
- D. In the event satisfactory adjustment cannot be reached for any item requiring a change in the Contract Price or Contract Time, and a Change Order has not been issued, CITY reserves the right at its sole option to either terminate the Contract as it applies to the items in question and make such arrangements as may be deemed necessary to complete the disputed work; or the work shall be performed on the "cost of work" basis as described in Article 10.4.
- E. On approval of any Contract change increasing the Contract Price, CONTRACTOR shall ensure that the performance bond and payment bond are increased so that each reflects the total Contract Price as increased.
- F. Under circumstances determined necessary by CITY, Change Orders may be issued unilaterally by CITY.

#### 10.4 Value of Change Order Work:

- A. The value of any work covered by a Change Order or of any claim for an increase or decrease in the Contract Price shall be determined in one of the following ways:
  - A.1 Where the work involved is covered by unit prices contained in the Contract Documents, by application of unit prices to the quantities of items involved, subject to the provisions of Article 10.4.G.
  - A.2 By mutual acceptance of a lump sum which CONTRACTOR and CITY acknowledge contains a component for overhead and profit.
  - A.3 On the basis of the "cost of work," determined as provided in this Article, plus a CONTRACTOR's fee for overhead and profit which is determined as provided in Article 10.4.D.
- B. The term "cost of work" means the sum of all direct costs necessarily incurred and paid by CONTRACTOR in the proper performance of the Work described in the Change Order. Except as otherwise may be agreed to in writing by CITY, such costs shall be in amounts no higher than those prevailing in the locality of the Project, shall include only the following items and shall not include any of the costs itemized in Article 10.4.C.
  - B.1 Payroll costs for employees in the direct employ of CONTRACTOR in the performance of the work described in the Change Order under schedules of job classifications agreed upon by CITY and CONTRACTOR. Payroll costs for employees not employed full time on the work covered by the



Change Order shall be apportioned on the basis of their time spent on the work. Payroll costs shall include, but not be limited to, salaries and wages plus the cost of fringe benefits which shall include social security contributions, unemployment, excise and payroll taxes, workers' or workmen's compensation, health and retirement benefits, bonuses, sick leave, vacation and holiday pay application thereto. Such employees shall include superintendents and foremen at the site. The expenses of performing the work after regular working hours, on Sunday or legal holidays shall be included in the above to the extent authorized by CITY.

- B.2 Cost of all materials and equipment furnished and incorporated in the work, including costs of transportation and storage thereof, and manufacturers' field services required in connection therewith. All cash discounts shall accrue to CONTRACTOR unless CITY deposits funds with CONTRACTOR with which to make payments, in which case the cash discounts shall accrue to CITY. All trade discounts, rebates and refunds, and all returns from sale of surplus materials and equipment shall accrue to CITY and CONTRACTOR shall make provisions so that they may be obtained. Rentals of all construction equipment and machinery and the parts thereof whether rented from CONTRACTOR or others in accordance with rental agreements approved by CITY with the advice of ENGINEER and the costs of transportation, loading, unloading, installation, dismantling and removal thereof, all in accordance with the terms of said agreements. The rental of any such equipment, machinery or parts shall cease when the use thereof is no longer necessary for the work.
- B.3 Payments made by CONTRACTOR to Subcontractors for work performed by Subcontractors, If required by CITY, CONTRACTOR shall obtain competitive bids from Subcontractors acceptable to CONTRACTOR and shall deliver such bids to CITY who will then determine, with the advice of ENGINEER, which bids will be accepted. If the Subcontract provides that the Subcontractor is to be paid on the basis of cost of the work plus a fee, the Subcontractor's cost of the work shall be determined in the same manner as CONTRACTOR'S cost of the work. All Subcontractors shall be subject to the other provisions of the Contract Documents insofar as applicable.
- B.4 Cost of special engineers, including, but not limited to, engineers, architects, testing laboratories, and surveyors employed for services specifically related to the performance of the work described in the Change Order.

- B.5 Supplemental costs including the following:  
The proportion of necessary transportation, travel and subsistence expenses of CONTRACTOR's employees incurred in discharge of duties connected with the work except for local travel to and from the site of the work.

Cost, including transportation and maintenance, of all materials, supplies, equipment, machinery, appliances, office and temporary facilities at the site and hand tools not owned by the workmen, which are consumed in the performance of the work, and cost less market value of such items used but not consumed which remains the property of CONTRACTOR.

Sales, use, or similar taxes related to the work, and for which CONTRACTOR is liable, imposed by any governmental authority. Deposits lost for causes other than CONTRACTOR's negligence; royalty payments and fees for permits and licenses. The cost of utilities, fuel, and sanitary facilities at the site. Receipted minor expenses such as telegrams, long distance telephone calls, telephone service at the site, expressage and similar petty cash items in connection with the work. Cost of premiums for additional bonds and insurance required because of changes in the work.

- C. The term "cost of the work" shall not include any of the following:

- C.1 Payroll costs and other compensation of CONTRACTOR's officers, executives, principals (of partnership and sole proprietorships), general managers, engineers, architects, estimators, lawyers, auditors, accountants, purchasing and contracting agents, expeditors, timekeepers, clerks and other personnel employed by CONTRACTOR whether at the site or in its principal or a branch office for general administration of the work and not specifically included in the agreed-upon schedule of job classifications referred to in this Article, all of which are to be considered administrative costs covered by CONTRACTOR's fee.
- C.2 Expenses of CONTRACTOR's principal and branch offices other than CONTRACTOR's office at the site.
- C.3 Any part of CONTRACTOR's capital expenses, including interest on CONTRACTOR's capital employed for the work and charges against CONTRACTOR for delinquent payments.
- C.4 Cost of premiums for all Bonds and for all insurance whether or not CONTRACTOR is required by the Contract Documents to purchase and maintain the same, except for additional bonds and insurance required because of changes in the work.
- C.5 Costs due to the negligence or neglect of CONTRACTOR, any Subcontractors, or anyone directly or indirectly employed by any of them or for whose acts any of them may be liable, including but not limited to, the correction of defective work, disposal of materials or equipment wrongly supplied and making good any damage to property.

- C.6 Other overhead or general expense costs of any kind and the cost of any item not specifically and expressly included in this Section.
- D. CONTRACTOR's fee allowed to CONTRACTOR for overhead and profit shall be determined as follows:
- D.1 A mutually acceptable fixed fee or if none can be agreed upon,
- D.2 A fee based on the following percentages of the various portions of the cost of the work:
- For costs incurred under Article 10.4.B.1, CONTRACTOR's fee shall not exceed ten percent (10%).
- For costs incurred under Article 10.4.B.3 and B.4, CONTRACTOR's fee shall not exceed seven and one half percent (7.5%); and if a subcontract is on the basis of cost of the work plus a fee, the maximum allowable to the Subcontractor as a fee for overhead and profit shall not exceed ten percent (10%);
- No fee shall be payable on the basis of costs itemized under Article 10.4.B.5 and Article 10.4.C.
- E. The amount of credit to be allowed by CONTRACTOR to CITY for any such change which results in a net decrease in cost, will be the amount of the actual net decrease. When both additions and credits are involved in anyone change, the combined overhead and profit shall be figured on the basis of the net increase, if any, however, CONTRACTOR shall not be entitled to claim lost profits for any Work not performed.
- F. Whenever the cost of any work is to be determined pursuant to Articles 10.4.B and 10.4.C, CONTRACTOR will submit in a form acceptable to CONSUL T ANT an itemized cost breakdown together with the supporting data.
- G. Where the quantity of any item of the Work that is covered by a unit price is increased or decreased by more than twenty percent (20%) from the quantity of such work indicated in the Contract Documents, an appropriate Change Order shall be issued to adjust the unit price, if warranted.
- H. Whenever a change in the Work is to be based on mutual acceptance of a lump sum, whether the amount is an addition, credit or no change-in-cost, CONTRACTOR shall submit an initial cost estimate acceptable to ENGINEER and CITY.
- H.1 Breakdown shall list the quantities and unit prices for materials, labor, equipment and other items of cost.
- H.2 Whenever a change involves CONTRACTOR and one or more Subcontractors and the change is an increase in the Contract Price, overhead and profit percentage for CONTRACTOR and each Subcontractor shall be itemized separately.

- I. Each Change Order must state within the body of the Change Order whether it is based upon unit price, negotiated lump sum, or "cost of the work."

10.5 Notification and Claim for Change of Contract Price:

- A. Any claim for a change in the Contract Price shall be made by written notice by CONTRACTOR to the CITY and to ENGINEER within five (5) calendar days of the commencement of the event giving rise to the claim and stating the general nature and cause of the claim. Thereafter, within twenty (20) calendar days of the termination of the event giving rise to the claim, written notice of the extent of the claim with supporting information and documentation shall be provided unless ENGINEER allows an additional period of time to ascertain more accurate data in support of the claim and such notice shall be accompanied by CONTRACTOR's written notarized statement that the adjustment claimed is the entire adjustment to which the CONTRACTOR has reason to believe it is entitled as a result of the occurrence of said event. All claims for changes in the Contract Price shall be in accordance with Articles 10.3 and 10.4 hereof, if CITY and CONTRACTOR cannot otherwise agree. **IT IS EXPRESSLY AND SPECIFICALLY AGREED THAT ANY AND ALL CLAIMS FOR CHANGES TO THE CONTRACT PRICE SHALL BE WAIVED IF NOT SUBMITTED IN STRICT ACCORDANCE WITH THE REQUIREMENTS OF THIS SECTION.**

10.6 Notice of Change:

If notice of any change affecting the general scope of the work or change in the Contract Price is required by the provisions of any Bond to be given to the Surety, it will be CONTRACTOR's responsibility to so notify the Surety, and the amount of each applicable Bond shall be adjusted accordingly. The CONTRACTOR shall furnish proof of such adjustment to the CITY. Failure of the CONTRACTOR to obtain such approval from the Surety may be a basis for termination of this Contract by the CITY.

10.7 Records:

The CONTRACTOR's representative and the ENGINEER shall compare records of extra work done at the end of the day. Such records shall be made in duplicate upon a form provided for such purpose by the ENGINEER and shall be signed by both the Inspector and the CONTRACTOR's representative, one copy being submitted to the ENGINEER and the other being retained by the CONTRACTOR.

10.8 Cancelled Items and Payments Therefore:

The CITY COMMISSION shall have the right to cancel those portions of the Contract relating to the construction of any item provided therein. Such cancellation shall entitle the CONTRACTOR to payment in a fair and equitable amount covering all items of cost incurred by him prior to the date of cancellation or suspension of the work. The CONTRACTOR shall be allowed a profit percentage on the materials used and on construction work actually performed, at the same rates as provided for "Extra Work", but no allowance will be made for anticipated profits. Acceptable materials ordered by the CONTRACTOR or delivered on the work, prior to date of such cancellation or suspension, may be purchased from the CONTRACTOR by the CITY at actual cost and shall thereupon, become property of the CITY, or may be returned to the manufacturer for a reasonable restocking charge.

10.9 Full Payment:

The Compensation herein provided shall be received and accepted by the CONTRACTOR as payment in full for all extra work done or costs incurred in event of cancellation.

## ARTICLE 11 - CHANGES IN THE CONTRACT TIME

### 11.1 Change Order:

The Contract Time may only be changed by a Change Order. A FULLY EXECUTED CHANGE ORDER MUST EXIST PRIOR TO EXTENSION OR SHORTENING OF THE CONTRACT TIME.

### 11.2 Notification and Claim for Change of Contract Time:

- A. Any claim for a change in the Contract Time shall be made by written notice by the CONTRACTOR to the CITY and to ENGINEER within five (5) calendar days of the commencement of the event giving rise to the claim and stating the general nature and cause of the claim. Thereafter within twenty (20) calendar days of the termination of the event giving rise to the claim, written notice of the extent of the claim with supporting information and documentation shall be provided unless ENGINEER allows an additional period of time to ascertain more accurate data in support of the claim and such notice shall be accompanied by CONTRACTOR's written notarized statement that the adjustment claimed is the entire adjustment to which the CONTRACTOR has reason to believe it is entitled as a result of the occurrence of said event. All claims for changes in the Contract Time shall be determined in accordance with Articles 10.3 and 10.4 hereof, if CITY and CONTRACTOR cannot otherwise agree. **IT IS EXPRESSLY AND SPECIFICALLY AGREED THAT ANY AND ALL CLAIMS FOR CHANGES TO THE CONTRACT TIME SHALL BE WAIVED IF NOT SUBMITTED IN STRICT ACCORDANCE WITH THE REQUIREMENTS OF THIS SECTION.**
- B. The Contract Time will be extended an amount equal to time lost on critical Work items due to delays beyond the control of and through no fault or negligence of CONTRACTOR if a claim is made thereafter as provided in Article 11.2. Such delays shall include, but not be limited to, acts or neglect by any separate contractor employed by CITY, fire, floods, labor disputes, epidemics, abnormal weather conditions or acts of God

### 11.3 Basis for Extension:

Extensions of time shall be considered and will be based solely upon the effect of delays to the work as a whole. Extensions of time shall not be granted for delays to the work, unless the CONTRACTOR can clearly demonstrate, through schedule analysis, that the delay to the work as a whole arose in accordance with Article 12.3 or Article 15.1, and that such delays did or will, in fact, delay the progress of work as a whole. Time extensions shall not be allowed for delays to parts of the work that are not on the critical path of the project schedule. Time extensions shall not be granted until all float or contingency time, at the time of the delay, available to absorb specific delays and associated impacts is used.

11.4 Change of Time Due to Contract Execution Problems:

Refer to Article 3.4 for a decrease in Contract Time when the CONTRACTOR fails to return the correctly executed Contract Documents within the time allowed.

11.5 Change of Time Due to Change Order Evaluation:

When evaluating a proposed Change Order, the ENGINEER shall have access to any available float or contingency time. Extension will only be considered in accordance with Article 11.3.

11.6 Change of Time and Inspection and Testing:

Neither observations by the ENGINEER, nor inspections, tests or approvals by others, passing or failing, will be cause for consideration of time extension.

11.7 Change of Time and Defective Work:

- A. If WORK is found to be defective, CONTRACTOR shall bear all remedial expenses including any additional costs experienced by CITY due to delays to others performing additional WORK. CONTRACTOR shall further bear the responsibility for maintaining schedule, and will be excluded from a time extension and the recovery of delay damages due to the uncovering.
- B. If the WORK is found to be defective per the Specifications, but the CITY chooses to accept it at its sole discretion, CONTRACTOR shall bear the responsibility for maintaining schedule, and will be excluded from a time extension and the recovery of delay damages due to the uncovering.

11.8 Liquidated Damages:

All time limits stated in the Contract Documents are of the essence. The provisions of this Article 11 shall not exclude recovery for damages by CITY as indicated in Section 3 of the Supplementary General Conditions.

ARTICLE 12 - WARRANTY AND GUARANTEE;  
TEST AND INSPECTIONS;  
CORRECTION, REMOVAL OR ACCEPTANCE OF DEFECTIVE WORK

12.1 Warranty and Guarantee:

The CONTRACTOR warrants and guarantees to the CITY and the ENGINEER that all work will be in accordance with the Contract Documents and will not be defective. Prompt notice of all defects shall be given to the CONTRACTOR. All defective work, whether or not in place, may be rejected, corrected or accepted as provided in this Article.

12.2 Tests and Inspections:

- A. The CONTRACTOR shall give the ENGINEER and, when appropriate, the Building Department and other regulatory authorities which have jurisdiction over the work, timely notice of readiness of the work for all required inspections, tests or approvals.
- B. All inspections performed as a result of the issuance of the Master Building Permit shall be performed by the CITY. All costs associated with such inspections shall be paid by the CITY, EXCEPT THAT should said test or inspection fail to pass the CONTRACTOR shall pay all costs associated with the rework and the retesting.
- C. When any other regulatory authority, by virtue of its rules or regulations, requires specific tests or inspections, the CONTRACTOR shall assume full responsibility for and pay all costs in connection with said tests and inspections.
- D. The CONTRACTOR shall also be responsible for and shall pay all costs in connection with any inspection or testing required in connection with the ENGINEER's acceptance of a manufacturer, fabricator, supplier or distributor of materials or equipment proposed to be incorporated in the work, or of materials or equipment submitted for approval prior to ENGINEER's acceptance thereof for incorporation in the work and as otherwise specified in the Contract Documents.
- E. Neither observations by the ENGINEER nor inspections, tests or approvals by others shall relieve the CONTRACTOR from his obligations to perform the work in accordance with the Contract Documents.

12.3 Uncovering Work:

- A. If any work that is to be inspected, tested or approved is covered without written concurrence of the ENGINEER, it must, if requested, by the ENGINEER, be uncovered. Such uncovering and replacement shall be at the CONTRACTOR's expense.



- B. CONTRACTOR must contact all regulatory agencies issuing construction permits to make all necessary inspections. If CONTRACTOR fails to have the necessary inspections performed and such failure results in uncovering of work already performed, CONTRACTOR shall be responsible for all related time delays and monetary costs.
- C. If the ENGINEER considers it necessary or advisable that work previously covered with his permission or cognizance be observed, inspected or tested, the CONTRACTOR, at the ENGINEER's request, shall uncover, expose or otherwise make available for observation, inspection or testing as the ENGINEER may require, that portion of the work in question, furnishing all necessary labor, material and equipment. If it is found that such work is defective, the CONTRACTOR shall bear all the expenses of such uncovering, exposure, observation, inspection and testing and of satisfactory reconstruction, including compensation for additional professional services. If, however, such work is not found to be defective the CONTRACTOR shall be allowed an increase in the Contract Price or an extension of the Contract Time, or both, directly attributable to such uncovering, exposure, observation, inspection, testing and reconstruction if he makes a claim therefor in accordance with Article 10.2 and Article 11.2.

#### 12.4 City May Stop the Work:

If the work is defective, or the CONTRACTOR fails to supply sufficient skilled workmen or suitable materials or equipment, the CITY may order the CONTRACTOR to stop the work, or any portion thereof, until the cause for such order has been eliminated; however, this right of the CITY to stop the work shall not give rise to any duty on the part of the CITY to exercise this right for the benefit of the CONTRACTOR or any other party.

#### 12.5 Correction or Removal of Defective Work:

If required by the ENGINEER, the CONTRACTOR shall promptly, without cost to the CITY and as specified by the ENGINEER either correct any defective work, whether or not fabricated, installed or completed, or if the work has been rejected by the ENGINEER, remove it from the site and replace it with nondefective work.

#### 12.6 One Year Correction Period:

If within one year after the date of Substantial Completion or Final Completion as applicable, or such longer period of time as may be prescribed by the terms of any applicable special guarantee required by the Contract Documents or by any specific provision of the Contract Documents, any work is found to be defective, the CONTRACTOR shall promptly without cost to the CITY and in accordance with the ENGINEER's written instructions, either correct such defective work, or if it has been rejected by the ENGINEER remove it from the site and replace it with nondefective work. If the CONTRACTOR does not promptly comply with the terms of such instructions, or in an emergency where delay would cause serious risk of loss or damage, the ENGINEER may have the defective work corrected or the rejected work removed and replaced, and all direct and indirect costs of such removal and replacement, including compensation for additional professional services, shall be paid by the CONTRACTOR.

#### 12.7 Acceptance of Defective Work:

If instead of requiring correction or removal and replacement of defective work, the ENGINEER prefers to accept it, he may do so. In such case, if acceptance occurs prior to the ENGINEER's recommendation of final payment, a Change Order shall be issued incorporating the necessary revisions in the Contract Documents, including appropriate reduction in the Contract Price; or if the acceptance occurs after such recommendation, an appropriate amount shall be paid by the CONTRACTOR to the CITY.

#### 12.8 City May Correct Defective Work:

If the CONTRACTOR fails within a reasonable time after written notice of the ENGINEER to proceed to correct and to correct defective work or to remove and replace rejected work as required by the ENGINEER in accordance with Paragraph 12.5, or if the CONTRACTOR fails to perform the work in accordance with the Contract Documents, (including any requirements of the progress schedule), the CITY may, after seven days' written notice to the CONTRACTOR, correct and remedy any such deficiency. In exercising its rights under this Paragraph the CITY shall proceed expeditiously. To the extent necessary to complete corrective and remedial action, the CITY may exclude the CONTRACTOR from all or part of the site, take possession of all or part of the work, and suspend the CONTRACTOR's services related thereto, take possession of the CONTRACTOR's tools, appliances, construction equipment and machinery at the site and incorporate in the work all materials and equipment stored at the site or for which the CITY has paid the CONTRACTOR but which are stored elsewhere. The CONTRACTOR shall allow the CITY, the CITY's representatives, agents and employees such access to the site as may be necessary to enable the CITY to exercise his rights under this Paragraph. All direct and indirect costs of the CITY in exercising such rights shall be charged against the CONTRACTOR in an amount verified by the ENGINEER, and a Change Order shall be issued incorporating the necessary revisions in the Contract Documents and a reduction in the Contract Price. Such direct and indirect costs shall include, in particular but without limitations, compensation for additional professional services required and all costs of repair and replacement of work of others destroyed or damaged by correction, removal or replacement of the CONTRACTOR's defective work. The CONTRACTOR shall not be allowed an extension of the Contract Time because of any delay in performance of the work attributable to the exercise by the CITY of the CITY's rights hereunder.

## ARTICLE 13 - PAYMENTS TO THE CONTRACTOR

### 13.1 Basis of Payment:

Progress payments shall be based on the aggregate of the unit price amounts listed in the Proposal or in the Schedule of Values which have been incorporated in the work acceptable to the ENGINEER.

### 13.2 Unit Price Inclusion:

The unit prices stated in the Proposal include all costs and expenses for materials, labor, tools, equipment, transportation, commissions, patent fees and royalties, removing crossings or other obstructions, protection or maintaining pipes, drains, railroad tracks, buildings, bridges, or other structures furnishing temporary crossings or bridges, furnishing all supplemental construction stakes, batter boards, templets, common and ordinary labor for handling materials during inspection replacing any property damage, together with any and all costs or expenses for performing and completing the work as specified.

### 13.3 Schedule of Values: (Lump Sum Price Breakdown)

A Schedule of Values must be submitted within seven days subsequent to the CONTRACTOR executing and submitting the Documents required of Article 2.13 of the Section II – Special Terms and Conditions. The schedules shall be satisfactory in form and substance to the ENGINEER, and shall include quantity and unit prices aggregating the Contract Price, and shall subdivide the work into component parts in sufficient detail to serve as the basis for progress payments during construction. Upon acceptance of the schedule of values by the ENGINEER, it shall be incorporated into a form of Application for Payment acceptable to the ENGINEER.

### 13.4 Changed Conditions: (Unit Price Only)

It is mutually agreed that due to latent field conditions which can not be foreseen at the time of advertising for bids, adjustments of the Plans to field conditions will be necessary during construction; and, therefore, such changes in the plans shall be recognized as constituting a normal and accepted margin of adjustment not unusual and not involving or permitting any change or modification of unit prices, in which case payment will be made for the revised quantities at the unit price bid in the Proposal.

### 13.5 Application for Progress Payment:

On the 20th day of the month or the first working day thereafter, the CONTRACTOR shall submit to the ENGINEER for review an Application for Payment form filled out and signed by the CONTRACTOR. The form shall be notarized, and shall cover the work completed as of the date of the application. The Application for Payment shall be accompanied by a Schedule of Values, and any other supporting documentation as the ENGINEER may reasonably require.

13.6 Payment for Materials:

If payment is requested on the basis of materials and equipment not incorporated in the work but delivered and suitably stored at the site or at another location agreed to in writing, the Application for Payment shall also be accompanied by such data, satisfactory to the ENGINEER, as will establish the CITY's title to the material and equipment and protect the CITY's interest therein, including applicable insurance.

13.7 Affidavit Required:

All Applications for Payment shall include an Affidavit of the CONTRACTOR stating that all previous progress payments received on account of the work have been applied to discharge in full all of CONTRACTOR's obligations reflected in prior Applications for Payment. The amount of retainage with respect to progress payments will be 5%.

13.8 Retainage:

The amount of retainage with respect to progress payments will be 5% until completion of the construction services purchased pursuant to the Contract.

13.9 CONTRACTOR's Warranty of Title:

The CONTRACTOR warrants and guarantees that title to all work, materials and equipment covered by any Application for Payment whether incorporated in the Project or not, will pass to the CITY at the time of payment free and clear of all liens, claims, security interests and encumbrances (hereinafter in these General Conditions referred to as "Liens").

13.10 Review of Application for Payment:

The ENGINEER will, within seven (7) days, review the Application for Payment and either approve and submit it for payment or notify the CONTRACTOR of the deficiencies such that the CONTRACTOR may make the necessary corrections and resubmit in time for the month's payment. However, the ENGINEER may refuse to recommend the whole or any part of any payment if, in his opinion, it would be incorrect to make such representations. He may also refuse to recommend any such payment, or because of subsequently discovered evidence or the results of subsequent inspections or tests, nullify any such payment previously recommended to such extent as may be necessary in the ENGINEER's opinion to protect the CITY from loss because:

- A. The work is defective, or completed work has been damaged requiring correction or replacement.
- B. Written claims have been made against the CITY or Liens have been filed in connection with the work.
- C. The Contract Price has been reduced because of Change Order.
- D. The CITY has been required to correct defective work or complete the work in accordance with Article 12.8.
- E. The CONTRACTOR's unsatisfactory prosecution of the work in accordance with the Contract Documents.
- F. The CONTRACTOR's failure to make payment to Sub- Contractors, or for labor, materials or equipment.

13.11 Payment to the Contractor:

Payments are made only on the fifteenth day or first workday thereafter of each month.

ARTICLE 14 - SUBSTANTIAL COMPLETION, PARTIAL UTILIZATION,  
FINAL CLEAN UP, INSPECTION, PAYMENT AND ACCEPTANCE

14.1 Substantial Completion:

When the CONTRACTOR considers the entire work ready for its intended use, the CONTRACTOR shall, in writing to the ENGINEER, certify that the entire work is substantially complete and request that the ENGINEER issue a Certificate of Substantial Completion. Within a reasonable time thereafter the CONTRACTOR and the ENGINEER shall make an inspection of the work to determine the status of completion. If the ENGINEER does not consider the work substantially complete, the ENGINEER will notify the CONTRACTOR in writing giving his reasons therefor. If the ENGINEER considers the work substantially complete, the ENGINEER will prepare and deliver to the CONTRACTOR a Certificate of Substantial Completion, which shall fix the date of Substantial Completion. There shall be attached to the certificate a proposed Punch List, developed by the CONTRACTOR, of items to be completed or corrected before final payment.

Within ten (10) days after delivery of the certificate, the CITY shall review the proposed Punch List and either approve it or contact the CONTRACTOR to commence good faith efforts to develop a Punch List that is satisfactory to both parties. If the parties are unable to resolve any differences they may have in the development of the Punch List, the ENGINEER shall resolve their differences. The parties shall expedite the process of developing the Punch List with the intent of finalizing the Punch List within sixty (60) days after the date of Substantial Completion.

At the time of delivery of the Certificate of Substantial Completion the ENGINEER will deliver to the CONTRACTOR written notice as to division of responsibilities pending final payment between the CITY and the CONTRACTOR with respect to security, operation, safety, maintenance, heat, utilities and insurance, said responsibilities will be binding on the CITY and the CONTRACTOR until final payment. Unless otherwise stated herein or on the Certificate of Substantial Completion, all building, product, equipment, and machinery warranties will commence on the date of Substantial Completion. The CITY shall have the right to exclude the CONTRACTOR from the work after the date of Substantial Completion, but the CITY shall allow the CONTRACTOR reasonable access to complete or correct items on the Punch List.

14.2 Partial Utilization:

Use by the CITY of any finished part of the work which has specifically been identified in the Contract Documents or which the ENGINEER and the CONTRACTOR agree constitutes a separately functioning and usable part of the work that can be used by the CITY without significant interference with CONTRACTOR's performance of the remainder of the work, may be accomplished prior to Substantial Completion of all the work subject to the following:

- A. The ENGINEER at any time may request the CONTRACTOR in writing to permit the CITY to use any such part of the work which the ENGINEER believes to be ready for its intended use and substantially complete. If the CONTRACTOR agrees, the CONTRACTOR will certify to the ENGINEER that said part of the work is substantially complete and request the ENGINEER to issue a Certificate of Substantial Completion for that part of the work. The CONTRACTOR, at any time, may notify the ENGINEER in writing that the CONTRACTOR considers any such part of the work ready for its intended use and substantially complete and request the ENGINEER to issue a Certificate of Substantial Complete for the part of the work. Within a reasonable time after either such request, the CONTRACTOR and the ENGINEER shall make an inspection of that part of the work to determine its status of completion. If the ENGINEER does not consider that part of the work to be substantially complete, the ENGINEER will notify the CONTRACTOR in writing giving the reasons therefore. If the ENGINEER considers that part of the work to be substantially complete, the provisions of Article 14.1 will apply with respect to Certificate of Substantial Completion of that part of the work and the division of responsibility in respect thereof and access thereto. It shall be understood by the CONTRACTOR that until such written notification is issued, all responsibility for care and maintenance of all of the WORK shall be borne by the CONTRACTOR. Upon issuance of said written notice of partial utilization, the OWNER will accept responsibility for the protection and maintenance of all such items or portions of the WORK described in the written notice.

#### 14.3 Final Clean-Up:

Upon completion of the work and before final inspection shall be made, the CONTRACTOR shall clean and remove from the site, the Right-of-Way and adjacent property, all surplus and discarded materials, rubbish, and temporary structures; restore in an acceptable manner all property, both public and private, which has been damaged during the prosecution of the work; and shall leave the site and vicinity unobstructed in a neat and presentable condition throughout the entire area or length of the work under Contract. The placing of materials of every character, rubbish, or equipment on the abutting property, with or without the consent of the property owners, shall not constitute the satisfactory disposal. If the work is of such a character as may be done by block or sections, the CONTRACTOR may be required to promptly remove and dispose of accumulated rubbish, debris or surplus materials from blocks or sections as completed or partially completed. No separate payment will be made for final cleaning up and restoration of property, but all costs thereof shall be included in the prices bid for the various scheduled items of work.

#### 14.4 Final Inspection:

Upon written notice from the CONTRACTOR that the entire work or an agreed portion thereof is complete and final clean-up has been completed, the ENGINEER will make a final inspection with the CONTRACTOR and will notify the CONTRACTOR in writing of all particulars in which this inspection reveals that the work is incomplete or defective. The CONTRACTOR shall immediately take such measures as are necessary to remedy such deficiencies.

#### 14.5 Final Application for Payment:

After the CONTRACTOR has completed all such corrections to the satisfaction of the ENGINEER and delivered all maintenance and operating instructions, schedules, guarantees, Bonds, certificates of inspection, marked-up record documents (as provided in Article 7.19 of the General Conditions and other documents; all as required by the Contract Documents and after the ENGINEER has indicated that the work is acceptable (subject to the provisions of Article 14.9) the CONTRACTOR may make Application for Final Payment following the procedure for progress payments. The final Application for Payment shall be accompanied by all documentation called for in the Contract Documents, together with complete and legally effective releases or waivers (satisfactory to the CITY) of all Liens arising out of or filed in connection with the work. In lieu thereof and as approved by the CITY, the CONTRACTOR may furnish receipts or releases in full; an affidavit of the CONTRACTOR that the releases and receipts include all labor, services, material and equipment for which a Lien could be filed, and that all payrolls, material and equipment bills, and other indebtedness connected with the work for which the CITY or the CITY's property might in any way be responsible, have been paid or otherwise satisfied; and consent of the Surety, if any, to final payment. If any Subcontractor or Supplier fails to furnish a release or receipt in full, the CONTRACTOR may furnish a Bond or other collateral satisfactory to the CITY to indemnify the CITY against any Lien.

#### 14.6 Final Payment and Acceptance:

If on the basis of the ENGINEER's observation of the work during construction and final inspection, and the ENGINEER's review of the final Application for Payment and accompanying documentation, all as required by the Contract Documents, the ENGINEER is satisfied that the work has been completed and the CONTRACTOR's other obligations under the Contract Documents have been fulfilled, the ENGINEER will recommend payment. Thereupon the ENGINEER will give written notice to the CITY and the CONTRACTOR that the work is acceptable subject to the provisions of Article 14.9.

#### 14.7 Payment of Retainage Without Final Completion:

If through no fault of the CONTRACTOR, final completion of the work is significantly delayed and if the ENGINEER so confirms, the CITY shall, upon receipt of the CONTRACTOR's final Application for Payment and recommendation of the ENGINEER, and without terminating the Agreement, make payment of the balance due for the portion of the work fully completed and accepted. If the remaining balance to be held by the CITY for work not fully completed or corrected is less than the retainage stipulated in the Agreement and if Bonds have been furnished as required in Article 5.2, the written consent of the Surety to the payment of the balance due for that portion of the work fully completed and accepted shall be submitted by the CONTRACTOR to the ENGINEER with the application for such payment. Such payment shall be made under the terms and conditions governing final payment, except that it shall not constitute a waiver of claims.



14.8 CONTRACTOR's Continuing Obligation:

The CONTRACTOR's obligation to perform and complete the work in accordance with the Contract Documents shall be absolute. Neither recommendation of any progress or final payment by the ENGINEER, nor the issuance of a Certificate of Substantial Completion, nor any payment by the CITY to the CONTRACTOR under the Contract Documents, nor any use or occupancy of the work or any part thereof by the CITY nor any act of acceptance by the CITY nor any failure to do so, nor any review and approval of a Shop Drawing or sample submission, nor the issuance of a notice of acceptability by the ENGINEER pursuant to Article 14.6, nor any correction of defective work by the CITY will constitute an acceptance of work not in accordance with the Contract Documents or a release of the CONTRACTOR's obligation to perform the work in accordance with the Contract Documents (except as provided in Article 14.9).

14.9 Waiver of Claims:

The making and acceptance of final payment will constitute:

- A. A waiver of all claims by the CITY against the CONTRACTOR, except claims arising from unsettled Liens, from defective work appearing after final inspection pursuant to Article 14.4 or from failure to comply with the Contract Documents or the terms of any special guarantees specified therein; however, it will not constitute a waiver by the CITY of any rights in respect of the CONTRACTOR's continuing obligations under the Contract Documents.
- B. A waiver of all claims by the CONTRACTOR against the CITY other than those previously made in writing and still unsettled.

## ARTICLE 15 - SUSPENSION OF WORK AND TERMINATION

### 15.1 City May Suspend Work:

The CITY may, at any time and without cause, suspend the work or any portion thereof for a period of not more than ninety (90) days by notice in writing to the CONTRACTOR which will fix the date on which work will be resumed. The CONTRACTOR shall resume the work on the date so fixed. The CONTRACTOR shall be allowed an increase in the Contract Price or an extension of the Contract Time, or both, directly attributable to any suspension.

### 15.2 City May Terminate:

- A. Upon the occurrence of any one or more of the following events:
1. If the CONTRACTOR commences a voluntary case under any chapter of the Bankruptcy Code (Title 11, United States Code), as now or hereafter in effect, or if the CONTRACTOR takes any equivalent or similar action by filing a petition or otherwise under any other federal or state law in effect at such time relating to the bankruptcy or insolvency.
  2. If a petition is filed against the CONTRACTOR under any chapter of the Bankruptcy Code as now or hereafter in effect at the time of filing, or if a petition is filed seeking any such equivalent or similar relief against the CONTRACTOR under any other federal or state law in effect at the time relating to bankruptcy or insolvency.
  3. If the CONTRACTOR makes a general assignment for the benefit of creditors.
  4. If a trustee, receiver, custodian or agent of the CONTRACTOR is appointed under applicable law or under contract, whose appointment or authority to take charge of property of the CONTRACTOR is for the purpose of enforcing a Lien against such property or for the purpose of general administration of such property for the benefit of the CONTRACTOR's creditors.
  5. If the CONTRACTOR admits in writing an inability to pay its debts generally as they become due.
  6. If the CONTRACTOR persistently fails to perform the work in accordance with the Contract Documents (including, but not limited to, failure to supply a qualified superintendent or sufficient skilled workers or suitable materials or equipment or failure to adhere to the approved progress schedule revised from time to time).
  7. If the CONTRACTOR disregards laws or regulations of any public body having jurisdiction.

8. If the CONTRACTOR disregards the authority of the ENGINEER.
  9. If the CONTRACTOR otherwise violates in any substantial way any provisions of the Contract Documents.
- B. The CITY may, after giving the CONTRACTOR and the Surety seven days' written notice and to the extent permitted by laws and regulations, terminate the services of the CONTRACTOR, exclude the CONTRACTOR from the site and take possession of the work and of all the CONTRACTOR's tools, appliances, construction equipment and machinery at the site and use the same to the full extent they could be used by the CONTRACTOR (without liability to the CONTRACTOR for trespass or conversion), incorporate in the work all materials and equipment stored at the site or for which the CITY has paid the CONTRACTOR but which are stored elsewhere, and finish the work as the CITY may deem expedient. In such case the CONTRACTOR shall not be entitled to receive any further payment until the work is finished. If the unpaid balance of the Contract Price exceeds the direct, indirect and consequential costs of completing the work (including but not limited to fees and charges of engineers, architects, attorneys and other professionals, and court and arbitration costs) such excess will be paid to the CONTRACTOR. If such costs exceed such unpaid balance, the CONTRACTOR, or CONTRACTOR's Surety, shall pay the difference to the CITY.
  - C. Where the CONTRACTOR's services have been so terminated by the CITY, the CITY alone shall determine the scope and description of the work to be completed and the method and schedule for completing it.
  - D. Where the CONTRACTOR's services have been so terminated by the CITY the termination will not affect any rights or remedies of the CITY against the CONTRACTOR then existing or which may thereafter accrue. Any retention or payment of moneys due the CONTRACTOR by the CITY will not release the CONTRACTOR from liability.
  - E. Upon seven days' written notice to the CONTRACTOR the CITY may, without cause and without prejudice to any other right or remedy, elect to abandon the work and terminate the Contract. In such case the CONTRACTOR shall be paid for all work executed and any expense sustained plus reasonable termination expenses, which will include, but not be limited to, direct, indirect and consequential costs (including, but not limited to, fees and charges of engineers, architects, attorneys and other professionals and court and arbitration costs).

15.3 Contractor May Stop Work or Terminate:

If through no act or fault of the CONTRACTOR, the work is suspended for a period of more than ninety (90) days by the CITY or under an order of court or other public authority, or the CITY fails for sixty (60) days to pay the CONTRACTOR any sum finally determined to be due, then the CONTRACTOR may, upon seven days' written notice to the CITY terminate the Contract and recover from the CITY payment for all work executed and any expense sustained plus reasonable termination expenses. In addition and in lieu of terminating the Contract, if the CITY has failed to make any payment as aforesaid, the CONTRACTOR may upon seven days' written notice to the CITY stop the work until payment of all amounts then due are paid. The provisions of this paragraph shall not relieve the CONTRACTOR of the obligations to carry on the work in accordance with the progress schedule and without delay during disputes and disagreements with the CITY.

- END OF SECTION -

ATTACHMENT C  
SUPPLEMENTARY GENERAL CONDITIONS  
INDEX TO ARTICLES

1. Project Schedule	00800-2
2. Insurance Requirements (Not Used)	00800-3
3. Liquidated Damages	00800-4
4. Restricted Area	00800-5
5. Existing Facilities and Structures	00800-5
6. Explosives	00800-5
7. Contract Documents	00800-5
8. Required Notifications	00800-5
9. Notice of Completion	00800-5
10. Prevailing Wage Requirement	00800-5
11. Inspections and Testing During Overtime	00800-6
12. Retainage	00800-6
13. Owner's Contingency (Not Used)	00800-8

**General Note:**

The General Conditions refer to specific section numbers in the Supplementary General Conditions. These reference numbers may not coordinate with the actual Article numbers utilized in the Supplementary General Conditions. The CONTRACTOR shall comply with all General Conditions and all Supplementary General Conditions as well as related conditions included in the General Requirements, Division 1 of the Technical Specifications. Incorrect cross-reference numbers shall not relieve this requirement.

**1. Project Schedule**

Time is of the essence for this work. The following defines the schedule for the project:

**CONSTRUCTION WORK SCHEDULE  
CONSTRUCTION / STARTUP / ACCEPTANCE:**

Major Milestones	Completion Time (Calendar Days)	Liquidated Damages (Per Day)
Clarifier No. 3 Repair Substantial Completion	<b>250</b>	<b>\$1,000.00</b>
Clarifier No. 3 Repair Project Closeout	<b>280</b>	<b>\$1,000.00</b>
Alternate Bid Items Substantial Completion	<b>450</b>	<b>\$1,000.00</b>
Alternate Bid Items Project Closeout	<b>480</b>	<b>\$1,000.00</b>

Failure to meet any of the above defined construction/startup/acceptance completion dates shall subject the CONTRACTOR to pay damages as specified in these Supplementary General Conditions in Article 3.

<sup>(1)</sup>Substantial Completion

1. Refer to Attachment B - General Conditions Articles 14.1 and 14.2. (Certification of Substantial Completion Services appended to the Supplementary General Conditions).
2. Substantial Completion shall also include:
  - Completion of all construction work associated with the specific "Major Milestone" listed in the construction work schedule including completion of punch list items. "Completion of punch list items" shall be as determined by the Engineer in the field.
  - Coating touchup completed.

- Record shop drawings and O&M submittals received and accepted by the Engineer.
- Record drawing red-lines received and accepted by the Engineer.
- Guarantee certifications, performance affidavits, and all other certifications received and accepted by the Engineer.

Contractor shall also conform to construction sequence constraints as defined on the Drawings and in Specifications.

<sup>(2)</sup>Project Closeout

1. Refer to Division 1 General Requirement, Section 01700 Project Closeout.
2. Project Closeout shall also include:
  - All requirements of substantial completion met plus the following
  - Site cleanup and restoration completed
  - All other sitework completed
  - Minor punch list items completed (minor as defined by the Engineer in the field)
  - Demobilization completed
  - Releases from all parties who are entitled to claims

The title "Engineer" utilized in these descriptions for substantial and final completion shall mean the City staff engineer assigned to this project, or his designated representative.

2. **Insurance Requirements (Not Used. Refer to ARTICLE 2.25 of SECTION II – SPECIAL TERMS AND CONDITIONS OF THE CONTRACT DOCUMENTS)**

**3. Liquidated Damages**

Liquidated damages shall be paid by the CONTRACTOR to the CITY for failure to complete work on time in accordance with the following schedule:

CONSTRUCTION/STARTUP/ACCEPTANCE:		
<u>Major Milestones</u>	<u>Completion Time (calendar days)</u>	<u>Liquidated Damages (Per Day)</u>
1. Clarifier No. 3 Repair Substantial Completion	<b>250</b>	<b>\$1,000.00</b>
2. Clarifier No. 3 Repair Project Closeout	<b>280</b>	<b>\$1,000.00</b>
3. Alternate Bid Items Substantial Completion	<b>450</b>	<b>\$1,000.00</b>
4. Alternate Bid Items Project Closeout	<b>480</b>	<b>\$1,000.00</b>

The CITY is hereby authorized to deduct the sums described above from the monies which may be due to the CONTRACTOR for the work under this contract. Liquidated damages shall be additive such that the maximum total which may be deducted shall be \$1000/day. Other damages for failure to meet warranty conditions as defined in other sections of the Specifications shall also be added with liquidated damages for failure to meet completion times.



4. **Restricted Area**

The CONTRACTOR shall, in installing the new facilities, confine all activities within the CITY property, easement, and right-of-ways indicated.

5. **Existing Facilities and Structures**

All existing facilities shall be protected, and if damaged, shall be repaired by the CONTRACTOR at no additional cost to the CITY.

6. **Explosives**

Explosives shall not be used on this project.

7. **Contract Documents**

The CITY will provide the CONTRACTOR with one (1) set of Contract Documents after the Notice to Proceed.

8. **Required Notifications**

When provisions of the pertinent codes, standards or regulations conflict with this Specification, the more stringent shall apply.

Prior to any site work, the CONTRACTOR shall notify the Engineering and Construction Services Division Inspector at (954) 921-3930.

Prior to excavation at the site, the CONTRACTOR shall notify the appropriate utilities and Sunshine State One-Call of Florida, Inc. (formerly U.N.C.L.E.) at 1-800-432-4770 for locations of buried utilities.

Prior to closure of any CITY streets or alleyways, or other activity which requires the diversion of traffic, the CONTRACTOR shall notify and obtain the permission of the CITY of Hollywood Fire and Police Communications Section at (954) 967-4321.

9. **Notice of Completion**

See attached form.

10. **Prevailing Wage Requirement**

A. The CONTRACTOR shall be responsible for ensuring payment of the rate of wages and fringe benefits, or cash equivalent, for all laborers, mechanics and apprentices employed by him/her or his/her SUBCONTRACTORS on the work covered by this contract which shall be not less than the prevailing rate of wages and fringe benefits payment or cash equivalent for similar skills or classifications of work as established by the General Wage Decision by the United States Department of Labor for Broward County, Florida that is in effect prior to the date the CITY issued the invitation for bids for this project (the prevailing rate of wages and fringes can be obtained at website <http://www.access.gpo.gov/davisbacon>).

If the General Wage Decision fails to provide for a fringe benefit rate for any worker classification, then the fringe benefit rate applicable to such worker classification shall be the fringe benefit rate that has a basic wage rate closest in dollar amount to the work classification for which no fringe benefit rate has been provided.

- B. Upon commencement of work, the CONTRACTOR and all of his/her SUB-CONTRACTORS shall post a notice in a prominent place at the work site stating the requirements of this Article.
- C. As per the City of Hollywood Code of Ordinances, Prevailing Wage Requirements and Fringe Benefits are applicable to the following: (A) Utilities projects over \$1,000,000.00 (one million dollars) and (B) All other projects over \$500,000.00 (five hundred thousand dollars).

## **11. Inspections and Testing During Overtime**

- A. The following supplement Article 3.15 and 3.16 of the General Conditions:

For weekend work, CONTRACTOR shall submit a written request to the CITY by the preceding Wednesday. A separate request is required for each week that the CONTRACTOR wished to work on a weekend. For evening and holiday work, CONTRACTOR shall submit a written request to the CITY three (3) days in advance. The CITY will provide inspection services for all overtime work and the CONTRACTOR shall pay for inspection services per Article 3.15, no exceptions.

Similarly, Holiday and other overtime work shall be requested a minimum of 36-hours in advance and CITY will provide inspection for all overtime.

- B. Exceptions to the hours and days of the week for work and other related limitations are allowed only for tie-ins during low flow periods / early morning hours, coatings that need to be applied during lower temperature times of the day and whenever the Documents specifically define that work shall be completed outside of the limitations for "normal" work hours, days, etc.

Inspection for tie-ins during low flow/early morning and specialty coating application performed during nighttime will not be cause for extra inspection costs unless such work is remedial in nature as a result of defective work.

## **12. Retainage**

After 50-percent completion of the construction services purchased pursuant to this contract, CONTRACTOR may present to CITY a payment request for one-half of the retainage then held by CITY. CITY shall promptly make payment to CONTRACTOR, unless CITY has grounds for withholding the payment of retainage. CITY shall have grounds for withholding the payment of retainage with respect to any amounts that are the subject of a good-faith dispute, the subject of a claim brought pursuant to Florida Statute Section 255.05, or otherwise the subject of a claim or demand by CITY or CONTRACTOR.

At acceptance of Substantial Completion, CITY shall promptly make payment to CONTRACTOR of one-half of the retainage then held by CITY. At acceptance of completion of all punch list items, CITY shall promptly make payment to CONTRACTOR the balance of retainage then held by CITY.

**13. Owner's Contingency (NOT USED)**

*This allowance is in its entirety dedicated for the use of the Owner (The City of Hollywood) to address conditions (or work) associated with undefined conditions. All work resulting from undefined conditions shall be authorized in writing and in advance by the Owner, specifically the Director of Public Services, through the full execution of a Field Order. The actual amount to be paid per Field Order will be negotiated and agreed by both parties (the Owner and the Contractor). The final/negotiated amount of the field order will be deducted from the Owner's Allowance designated in the Bid Proposal and Schedule of Values. The Owner reserves the right to award none, any portion of, or all of the money associated with this allowance. By executing the CONTRACT between the City of Hollywood and the Contractor, the Contractor acknowledges that under no circumstances he or she should assume that he or she would be entitled to any amounts set aside by the City of Hollywood within the Owner's Allowance.*

# CERTIFICATE OF SUBSTANTIAL COMPLETION

**PROJECT:**

**ENGINEER:**

**TO:**

**CONTRACTOR:**

**CONTRACT FOR:**

**NOTICE TO PROCEED DATE:**

**DATE OF ISSUANCE:**

**PROJECT OR DESIGNATED PORTION SHALL INCLUDE:**

Portions of the work performed under this Contract as described above, have been reviewed and found to be substantially complete. The Date of Substantial Completion of Project or designated portion thereof designated above is hereby established as \_\_\_\_\_ which is also the date of commencement of applicable warranties required by the Contract Documents for the noted area.

## **DEFINITION OF DATE OF SUBSTANTIAL COMPLETION**

The Date of Substantial Completion of the work or designated portion thereof is the date certified by the ENGINEER ("Date of Issuance" above) when construction is sufficiently complete, in accordance with the Contract Documents, so the CITY can occupy or utilize the work or designated portion thereof for the use for which it is intended, as expressed in the Contract Documents.

A list of items to be completed or corrected, prepared by the CONTRACTOR and verified and amended by the ENGINEER, for the above referenced "Project or Designated Portion" is attached to this form (attached "Punch List" dated \_\_\_\_\_).

The failure to include any items on such list does not alter the responsibility of the CONTRACTOR to complete all work in accordance with the Contract Documents.

# CERTIFICATE OF SUBSTANTIAL COMPLETION

Please note that in accordance with Article 14 General Conditions, Public Utilities the Contractor retains full responsibility for the satisfactory completion of all work regardless of whether the Owner occupies and / or operates a part of the facility and that the taking possession and use of such work shall not be deemed an acceptance of any work not completed in accordance with the Contract Documents.

---

**ENGINEER**

**BY**

**DATE**

---

**CONTRACTOR**

**BY**

**DATE**

The CITY OF HOLLYWOOD, through the City's authorized representative, accepts the work or designated portion thereof as substantially complete and will assume full possession thereof at \_\_\_\_\_(time) on \_\_\_\_\_  
\_\_\_\_\_ (date).

---

**BY**

**DATE**

- END OF SECTION -



**CITY OF HOLLYWOOD  
DEPARTMENT OF PUBLIC UTILITIES  
ENGINEERING & CONSTRUCTION SERVICES DIVISION**

1621 N. 14<sup>th</sup> Avenue  
Hollywood, FL 33022  
Phone (954) 921-3930 Fax (954) 921-3258

**ADDENDUM NUMBER 3**

Date: **February 15, 2023**

FOR: **Clarifier No. 3 Repair**

BID NUMBER: **REQ-038-23-JJ**

ALL BIDDERS BE ADVISED OF THE FOLLOWING CHANGES TO THE ABOVE REFERENCED PROJECT AS LISTED BELOW:

This addendum is issued as part of the Bidding Documents for the above-described project. **The changes incorporated in this addendum shall be considered as a part of the documents and shall supersede, amend, add to, clarify, or subtract from those conditions shown in the original documents dated January 10, 2023.** The bidder shall coordinate all modifications herein with all trades and disciplines related to the work. The Bidder shall acknowledge receipt of this addendum on the Bid Form by addendum number and date. Failure to do so may subject Bidder to disqualification.

**Item 1: Update Bid Dates**

Bid Due Date has been extended to February 23, 2023 at 3:00pm EST  
Deadline for questions was extended to February 16, 2023 at 5:00pm EST

**Item 2: Updated Mechanical Drawing M-03**

Drawing M-03 has been updated to include patching of the center column opening in Clarifier No. 3.

**Item 3: Updated Bid Form**

Bid Item 3 has been updated to include miscellaneous construction costs, reinstallation of the Clarifier No. 3 mechanism, and other related work.

**Item 4: Additional Updated Specifications**

- Section 01025 – Basis of Payment
- Section 06620 – Scum Baffles and Weir Plates (Alternate Bid Item)
- Section 06650 – Density Current Baffles (Alternate Bid Item)
- Section 11232 – Final Clarifier Mechanism Replacement (Alternate Bid Items)

ALL OTHER TERMS, CONDITIONS AND SPECIFICATIONS SHALL REMAIN THE SAME.

THIS ADDENDUM SHALL BE ATTACHED TO THE CONTRACT DOCUMENTS AND THE RECEIPT OF THE SAME SHALL BE NOTED IN THE PROPOSAL IN THE SPACE PROVIDED.

# FORM 3

## BID FORM

The City is seeking bids/proposals from qualified vendors for the items listed below in accordance with the terms, conditions, and specifications contained in this solicitation.

Estimated quantities listed are for information and tabulation purposes only. No warranty or guarantee of quantities needed is given or implied. It is understood that the Contractor will furnish the City's needs as they arise.

### BASE BID

Item No.	Position Classifications	Quantity	Unit	Unit Price	Total
1.	Mobilization (shall not exceed 3% of the sum of Bid Items No. 2 and No. 3).	1	Lump Sum	\$	\$
2.	<u>Clarifier No. 3 Repair</u> : All work required for the repair of a failed 16-inch diameter 90-degree elbow joint and pipe segment on the return sludge line (ductile iron pipe) located below grade within the 48-inch diameter clarifier feed line at Clarifier No. 3, as required in the Contract Documents.	1	Lump Sum	\$	\$
3.	<u>Clarifier No. 3 Reinstallation of Mechanism</u> : All work required for the reinstallation of Clarifier No. 3 mechanism if removed under Bid Item No. 2, including reassembly/installation of existing equipment post-repair, and all work necessary to return clarifier to service.	1	Lump Sum	\$	\$
4.	Permit Fee Allowance	1	Allowance	\$50,000	\$50,000
5.	Undefined Conditions Allowance	1	Allowance	\$285,000	\$285,000
6.	Consideration for Indemnification	1	\$10	\$10	\$10
7.	Demobilization (shall not exceed 3% of the sum of Bid Items No. 2 and No. 3).	1	Lump Sum	\$	\$

### Miscellaneous Construction

8.	Field Crew (Superintendent)	40	hr	\$	\$
9.	Field Crew (Operator)	40	hr	\$	\$
10.	Field Crew (Laborer x 2)	40	hr	\$	\$
11.	Equipment, Excavator, 5 CY	40	hr	\$	\$
12.	Equipment, Flat Bed Truck, 12'	40	hr	\$	\$
13.	Equipment, Loader	40	hr	\$	\$

**GRAND TOTAL BASE BID PRICE**

\$

**GRAND TOTAL BASE BID PRICE (in words):**

**ALTERNATE BID ITEMS**

The following items are at the City's option and shall not be included in the Total Base Bid, shall not affect the Contract Award, and shall not affect substantial and final completion time requirements.

Item No.	Position Classifications	Quantity	Unit	Unit Price	Total
A-1.	<u>Furnish and Install Clarifier No. 3 Equipment (Complete Mechanism Replacement, Carbon Steel)</u> : All work for complete replacement of the mechanism at Clarifier No. 3, in the event it is deemed necessary. The material of the replacement mechanism shall be carbon steel components with required surface preparation and coating system per the Contract documents. Work includes but is not limited to furnishing, delivering, installing and testing Clarifier No. 3 drive and associated appurtenances.	1	Lump Sum	\$	\$
A-2.	<u>Furnish and Install Clarifier No. 3 Equipment (Complete Mechanism Replacement, 316 Stainless Steel)</u> : All work for complete replacement of the mechanism at Clarifier No. 3, in the event it is deemed necessary. The material of the replacement mechanism shall be 316 stainless steel components per the Contract documents. Work includes but is not limited to furnishing, delivering, installing and testing Clarifier No. 3 drive and associated appurtenances.	1	Lump Sum	\$	\$
A-3.	<u>Furnish and Install Clarifier No. 3 Weirs and Scum Baffles</u> : All work for replacement of the fiberglass v-notched weirs and scum baffles at Clarifier No. 3, in the event it is deemed necessary. Item shall include payment for all labor, equipment, and materials for all work necessary and required for the replacement of equipment, as detailed in the Contract Documents, for a complete and operable system.	1	Lump Sum	\$	\$
A-4.	<u>Furnish and Install Clarifier No. 3 Density Current Baffles</u> : All work for replacement of the density current baffles at Clarifier No. 3, in the event it is deemed necessary. Item shall include payment for all labor, equipment, and materials for all work necessary and required for the replacement of equipment, as detailed in the Contract Documents, for a complete and operable system.	1	Lump Sum	\$	\$

\_\_\_\_\_  
Company Name

\_\_\_\_\_  
Authorized Signature

\_\_\_\_\_  
Print Name

\_\_\_\_\_  
Title

\_\_\_\_\_  
Date



NOTE:  
CLARIFIER No. 3 SHOWN.



**CLARIFIER No. 3 EXISTING  
16-INCH RAS LINE REPAIR**

**PHOTO 1**  
NTS

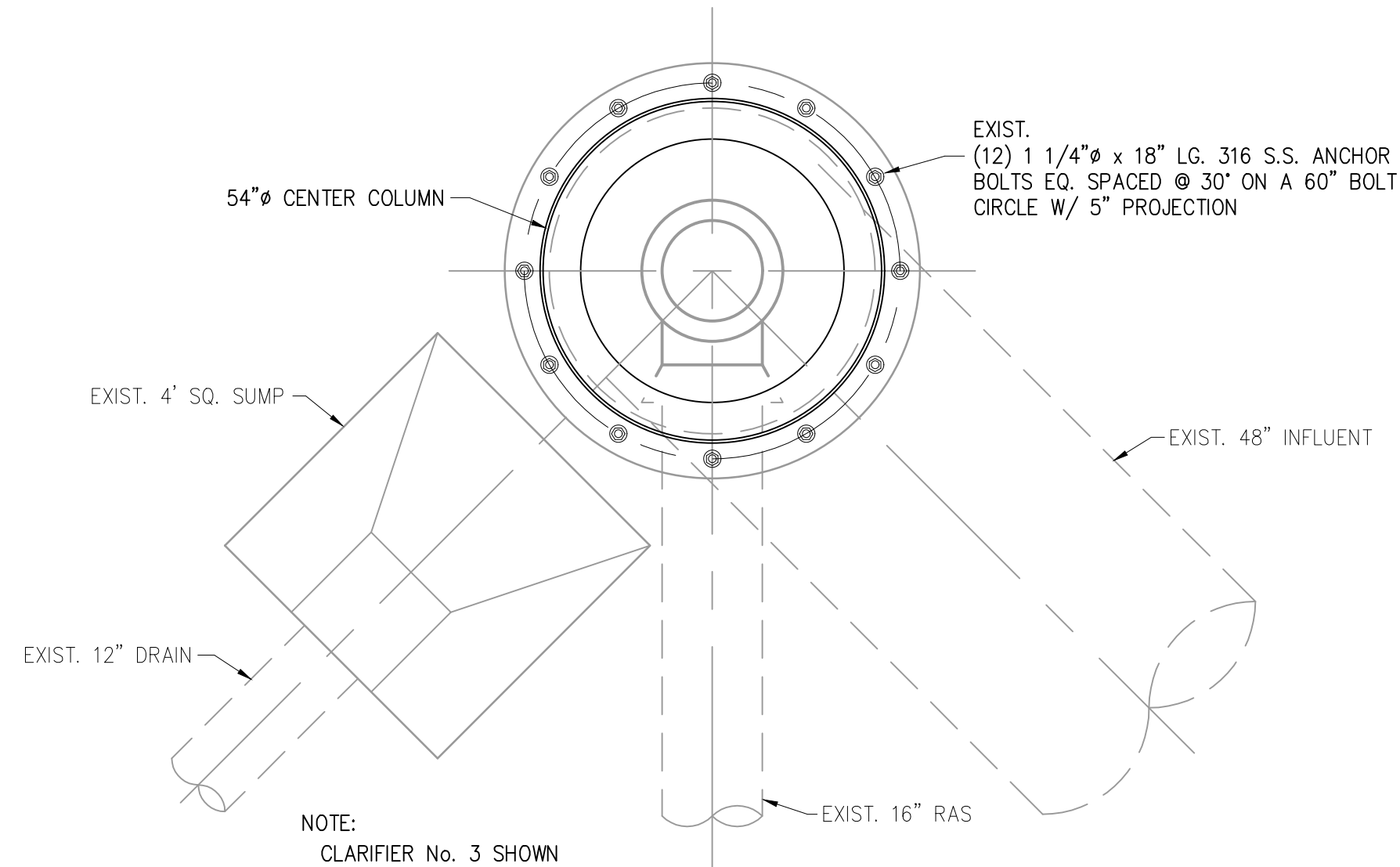

**REPAIR  
PLAN**

1/2"=1'-0"

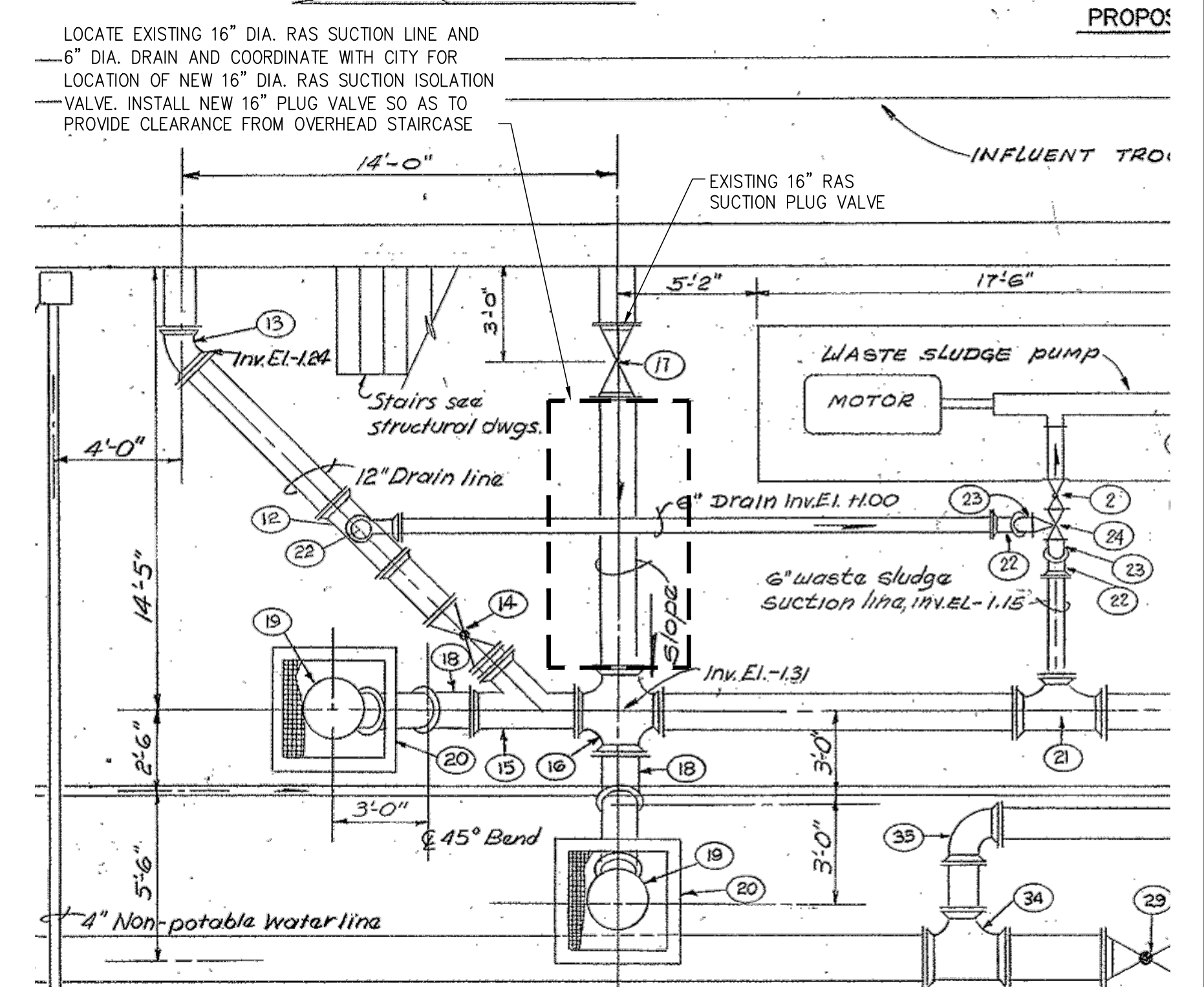

**16" PLUG VALVE LOCATION  
DETAIL**

NTS

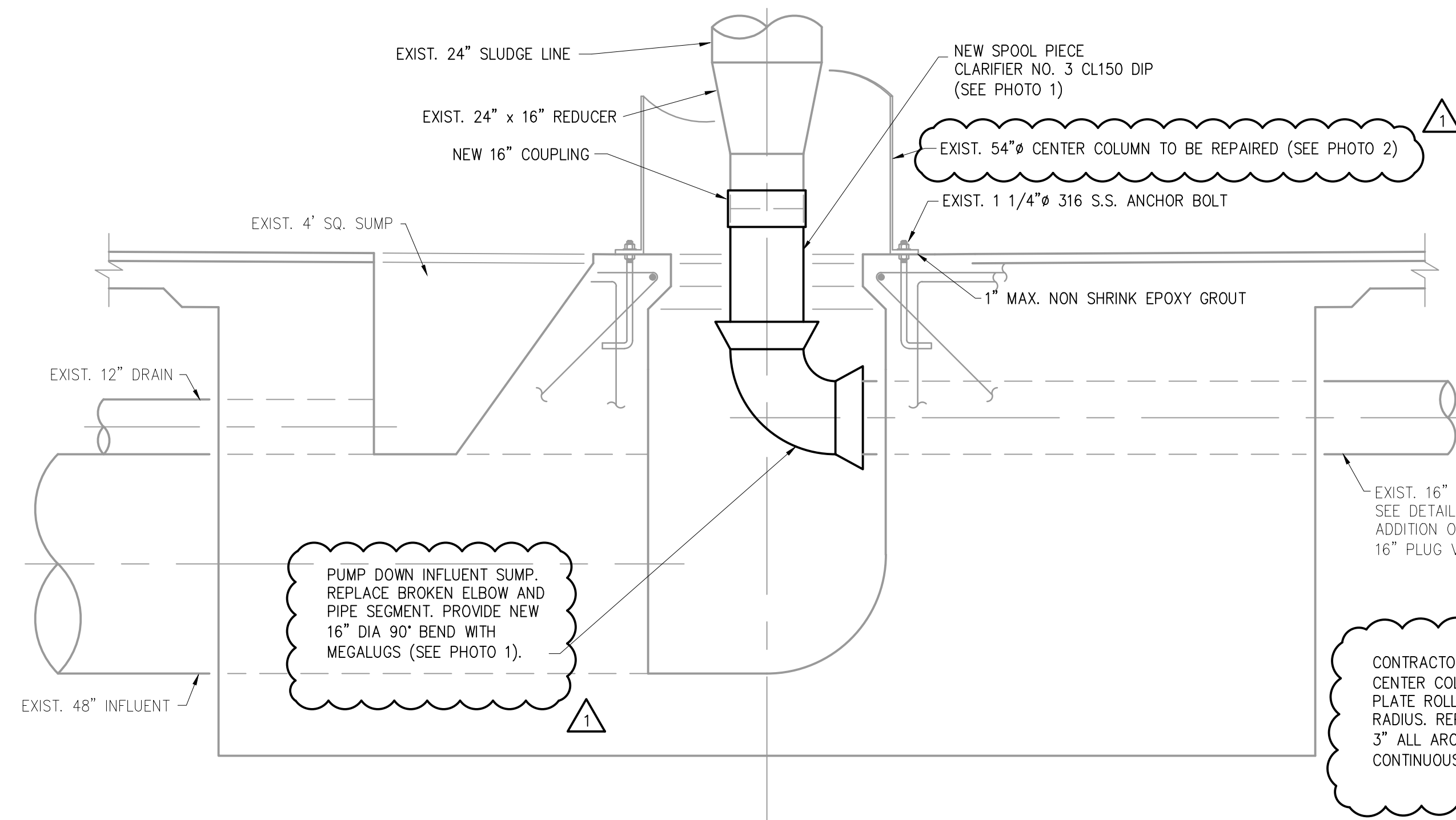

**REPAIR  
ILLUSTRATIVE CROSS SECTION**

1/2"=1'-0"

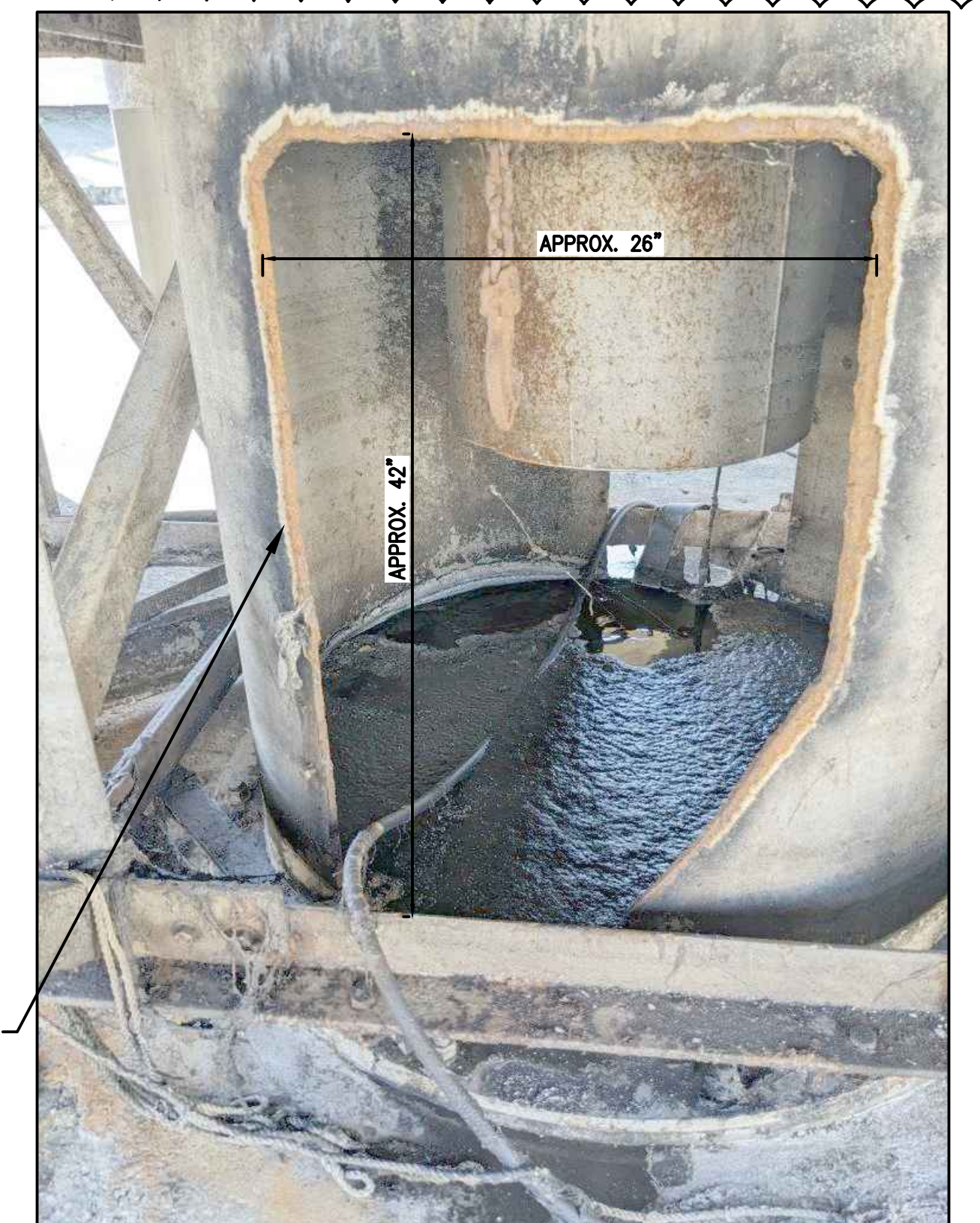

**CENTER COLUMN OPENING TO BE REPAIRED**

**PHOTO 2**  
NTS

**LEGEND**

- EXISTING FACILITIES
- NEW FACILITIES
- ▨ TO BE REMOVED

1/2"=1'-0" 12' 0 1 3'

PLOT DATE: 2/3/2023 2:51 PM BY: TBC/AS

DESIGNED	TAV		
DRAWN	TB		
CHECKED	JPC		
PROJ. ENGR.	TAV		
NO.	DATE	ISSUED FOR	BY
1	2/8/23	ADDENDUM No. 2	JPC

DESIGNED	TAV	J. PHILIP COOKE No. 47137	P.E.
DRAWN	TB		
CHECKED	JPC		
PROJ. ENGR.	TAV		

**Hazen**  
HAZEN AND SAWYER  
4000 HOLLYWOOD BOULEVARD, SUITE 750N  
HOLLYWOOD, FLORIDA 33021

THE SCALE BAR SHOWN BELOW MEASURES ONE INCH LONG ON THE ORIGINAL DRAWING.

CONTRACT:	-
CLIENTS PROJECT:	22-9525
ENGINEERS PROJECT:	4321-095
CAD REFERENCE:	8242-095-M03

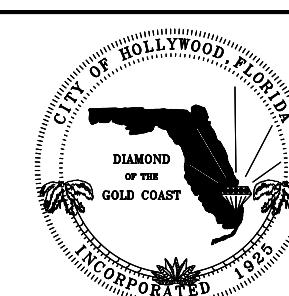

CITY OF HOLLYWOOD

SOUTHERN REGIONAL WASTEWATER TREATMENT PLANT

CLARIFIER No. 3 REPAIR

CLARIFIER NO.3 REPAIR - DETAILS

DATE: JANUARY 2023

SHEET: 06 OF 17

DRAWING: M-3

BID SET

## SECTION 01025 - BASIS OF PAYMENT

### PART 1 -- GENERAL

#### 1.01 GENERAL

- A. Payments to the CONTRACTOR shall be made on the basis of the Proposal bid items as full and complete payment for furnishing all materials, labor, tools and equipment, and for performing all operations necessary to complete the work included in the Contract Documents. Such compensation shall also include payments for any loss or damages arising directly or indirectly from the work, or from any discrepancies between the actual quantities of work and those shown in the Contract Documents, or from any unforeseen difficulties which may be encountered during the prosecution of the work until the final acceptance by the CITY.
- B. The prices stated in the proposal include all costs and expenses for taxes, labor, equipment, materials, commissions, transportation charges and expenses, patent fees and royalties, labor for handling materials during inspection, together with any and all other costs and expenses for performing and completing the work as shown on the plans and specified herein. The Basis of Payment for an item at the price shown in the Proposal shall be in accordance with its description of the item in this Section and as related to the work specified and as shown on the Drawings. Unit prices where used will be applied to the actual quantities furnished and installed in conformance with the Contract Documents.
- C. The CONTRACTOR's attention is called to the fact that the quotations for the various items of work are intended to establish a total price for completing the work in its entirety. Should the CONTRACTOR feel that the cost of any item of work has not been established by the Proposal or Basis of Payment, he shall include the cost for that work in the last Bid Item so that his proposal for the project does reflect his total price for completing the work in its entirety.

#### 1.02 MEASUREMENT

- A. The quantities for payment under this Contract shall be determined by actual measurement of the completed items, in place, ready for service and accepted by the CITY, in accordance with the Schedule of Payment Values as described in Section 01300, unless otherwise specified. A representative of the CONTRACTOR shall witness all field measurements.

## 1.03 PAYMENT ITEMS

### A. Base Bid Items

1. Item No. 1 – Mobilization: The lump sum price bid for this item shall be full compensation for all mobilization activities, including but not limited to bonds, insurance, scheduling, labor associated with permit acquisition, temporary facilities, audio-video documentation of the existing site, preparation and submittal of shop drawings, and all other activities necessary to prepare to complete the contract work. The payment item for mobilization shall not exceed 3% of the sum of Bid Item Nos. 2 through 3.
2. Item No. 2 – Clarifier No. 3 Repair: Payment for all labor, equipment, and materials for all work necessary and required for the repair of a failed 16-inch diameter 90-degree elbow joint and pipe segment on the return sludge line (ductile iron pipe) located below grade within the 54-inch diameter clarifier feed line at Clarifier No. 3, as required in the Contract Documents. Due to the location of the repair work, this item also includes dismantling and removal of the clarifier mechanism as necessary to perform said repair work, and protection and storage of existing equipment. In addition, this item includes all work necessary to furnish and install a 16-inch diameter plug valve on the return sludge line on the west side of Clarifier No. 3 as shown on the drawings, installation and start-up of City-furnished clarifier drive, repair and re-installation of one (1) finger weir, replacement and re-wiring of ten (10) type LB conduit bodies (up to 2") in-kind, replacement of ten (10) conduit couplings up to 2" in size, replacement and re-wiring of ten (10) GFCI receptacles and outlet boxes, repair of center column opening (approximately 26"x42") with welded plate, and re-attachment of center column access hatch. This item includes, but is not limited to, all general, civil, mechanical, structural, architectural, electrical, instrumentation and control work required to perform the repair, as specified in the Contract Documents. Bid Item No. 2 includes all work for Clarifier No. 3 not defined in other Bid Items.
3. Item No. 3 – Clarifier No. 3 Re-installation of Mechanism: Payment for all labor, equipment, and materials for all work necessary and required for the reinstallation of the clarifier mechanism if removed to facilitate work performed under Bid Item No. 2. This item includes, but is not limited to, all general, civil, mechanical, structural, architectural, electrical, instrumentation and control, equipment testing, startup services and construction sequencing required for a complete and operable system. Any existing concrete damaged during the work shall be repaired according to the Contract documents.
4. Item No. 4 – Permit Fee Allowance: Payment for permit fees will be based upon the actual permit fees required by the Contractor from the various agencies having jurisdiction for construction of the project, in accordance with the Contract Documents. The allowance amount shown on the bid schedule is an estimate of permit fees required for the project and is a cost pass-through item. No mark-ups will be allowed to this item. The Contractor shall produce documentation upon request verifying actual cost. Only permit fees substantiated by the Contractor and approved by the Engineer will be paid as part of this bid item. Any portion of this allowance that remains after all authorized payments have been made will be withheld from contract payments and will

remain with the City of Hollywood. Fees specifically excluded from this allowance include re-inspection fees and expired permit fees.

5. Item No. 5 – Undefined Conditions Allowance: Included in this allowance is work associated with undefined conditions or conflicts developing from undefined conditions. All work authorized for payment will be authorized in writing by the CITY. Amount to be paid per undefined conditions or conflicts shall be negotiated or agreed to by both parties. Any portion of this allowance that remains after all authorized payments have been made will be withheld from contract payments and will remain with the City of Hollywood.
6. Item No. 6 – Consideration for Indemnification: In recognition of CONTRACTOR's indemnification obligations, the CITY will pay to the CONTRACTOR the specific consideration of ten dollars (\$10.00). Payment of said specific consideration shall be made at the time of the payment of the first progress estimate and the CONTRACTOR shall acknowledge payment of this consideration by letter to the CITY after receipt of the progress payment.
7. Item No. 7 – Demobilization: Payment for completing all other work including but not limited to demobilization, site cleanup and restoration - all as per the Technical Specifications and Contract Drawings. The payment items for demobilization shall not exceed 2% of the sum of Bid Item Nos. 2 through 3.
8. Item Nos. 8 through 13 – Miscellaneous Construction:
  - a) Payment under this item is limited to work not already in other pay items of this contract. Scope of work to be determined by the City of Hollywood.
  - b) Payment for these items shall be made at the unit price named in the Schedule of Values.
  - c) Payment of these items shall constitute full compensation for all labor, equipment, material, and work performed in furnishing and installing agreed upon items, all in accordance with the requirements of the contract documents.

B. Alternate Bid Items

The following items are at the CITY's option and shall not be included in the Total Base Bid.

- A-1. Item No. A-1 – Furnish and Install Clarifier No. 3 Equipment (Complete Mechanism Replacement, Carbon Steel): The following item is for complete replacement of the mechanism at Clarifier No. 3, in the event it is deemed necessary. The material of the replacement mechanism shall be carbon steel components with required surface preparation and coating system per the Contract documents. Item shall include payment for all labor, equipment, and materials for all work necessary and required for the replacement of equipment as detailed in the Contract Documents. This item includes, but is not limited to, all general, civil, mechanical, structural, architectural, electrical, instrumentation and control, equipment testing, shop drawing submittal, startup services and construction sequencing required for a complete and operable system. Work includes but is not limited to re-mobilization, furnishing, delivering,

installing, testing Clarifier No. 3 drive and associated appurtenances and demobilization. This item includes the removal and replacement of up to 300 linear feet of Schedule 80 PVC piping, 3 inches in diameter or less not already shown to be removed and replaced on the Drawings. Electrical and instrumentation work includes replacement of conduit and wiring for the clarifier and all work necessary to provide local and remote controls and displays required in the Contract Documents.

- A-2 Item No. A-2 – Furnish and Install Clarifier No. 3 Equipment (Complete Mechanism Replacement, 316 Stainless Steel): The following item is for complete replacement of the mechanism at Clarifier No. 3, in the event it is deemed necessary. The material of the replacement mechanism shall include 316 stainless steel components per the Contract documents. Item shall include payment for all labor, equipment, and materials for all work necessary and required for the replacement of equipment as detailed in the Contract Documents. This item includes, but is not limited to, all general, civil, mechanical, structural, architectural, electrical, instrumentation and control, equipment testing, shop drawing submittal, startup services and construction sequencing required for a complete and operable system. Work includes but is not limited to re-mobilization, furnishing, delivering, installing, testing Clarifier No. 3 drive and associated appurtenances and demobilization. This item includes the removal and replacement of up to 300 linear feet of Schedule 80 PVC piping, 3 inches in diameter or less not already shown to be removed and replaced on the Drawings. Electrical and instrumentation work includes replacement of conduit and wiring for the clarifier and all work necessary to provide local and remote controls and displays required in the Contract Documents.
- A-3 Item No. A-3 – Furnish and Install Clarifier No. 3 Weirs and Scum Baffles: The following item is for replacement of the fiberglass v-notched weirs and scum baffles at Clarifier No. 3, in the event it is deemed necessary. Item shall include payment for all labor, equipment, and materials for all work necessary and required for the replacement of equipment, as detailed in the Contract Documents, for a complete and operable system.
- A-4 Item No. A-4 – Furnish and Install Clarifier No. 3 Density Current Baffles: The following item is for replacement of the density current baffles at Clarifier No. 3, in the event it is deemed necessary. Item shall include payment for all labor, equipment, and materials for all work necessary and required for the replacement of equipment, as detailed in the Contract Documents, for a complete and operable system.

PART 2 -- PRODUCTS (Not Used)

PART 3 -- EXECUTION (Not Used)

- END OF SECTION -

SECTION 06620 – SCUM BAFFLES AND WEIR PLATES  
(ALTERNATE BID ITEM)

PART 1 -- GENERAL

1.01 THE REQUIREMENT

- A. As part of the Base Bid, the CONTRACTOR shall perform all work necessary to bring Clarifier No. 3 to a fully operable system, including removal and re-installation of existing equipment, per the Contract Documents. At the CITY's option under an Alternate Bid Item, the CONTRACTOR shall furnish and install scum baffles and weir plates as shown on the Contract Drawings, shop drawings and specified herein.

1.02 RELATED WORK SPECIFIED ELSEWHERE

- A. Precast Concrete
- B. Metal Fabrications
- C. Sealants and Caulking

1.03 REFERENCE SPECIFICATIONS, CODES, AND STANDARDS

A. Commercial Standards

- |     |            |  |
|-----|------------|--|
| 1.  | ASTM A193  | Specification for Carbon Alloy-Steel and Stainless Steel Bolting Materials for High-Temperature Service                                      |
| 2.  | ASTM A194  | Specification for Carbon Alloy-Steel Nuts for Bolts for High-Pressure and High Temperature Service   |
| 3.  | ASTM C581  | Practice for Determining Chemical Resistance of Thermosetting Resins Used in Glass Fiber Reinforcing Structures, Intended for Liquid Service |
| 4.  | ASTM D256  | Test Methods for Impact Resistance of Plastics and Electrical Insulating Materials   |
| 5.  | ASTM D570  | Test Method for Water Absorption of Plastics   |
| 6.  | ASTM D638  | Test Method for Tensile Properties of Plastics   |
| 7.  | ASTM D696  | Test Method for Coefficient of Linear Thermal Expansion of Plastics  |
| 8.  | ASTM D790  | Test Methods for Flexural Properties of Unreinforced and Reinforced Plastics and Electrical Insulating Materials                             |
| 9.  | ASTM D2563 | Recommended Practice for Classifying Visual Defects in Glass-Reinforced Plastic Laminate Parts   |
| 10. | ASTM D2583 | Test Method for Indentation Hardness of Rigid Plastics by Means of a Barcol Impressor  |

#### 1.04 GENERAL INFORMATION AND DESCRIPTION

- A. Weir plates shall be 90° V-notch type, 4-inches center to center for Clarifier No. 3, as indicated on the Drawings. Serpentine weirs, complete with supports, etc., shall be provided in the corners of Clarifier No. 3 as indicated on the Drawings. Scum baffles shall be 12 inches high with a 24 inch high section located at each scum box.

#### 1.05 SUBMITTALS

- A. The CONTRACTOR shall submit shop drawings, detailed installation drawings and other information to the ENGINEER for review in accordance with the Section entitled "Submittals".
- B. Submittals shall include: FRP manufacturer; resins used; assembly and erection details; sizes; profiles; fasteners and their proper torque load to be applied; supports; anchors; finishes; colors; clearances; and connections to other work.
- C. Submit two (2) samples of each type of baffle and weir plate to the ENGINEER.

#### 1.06 MANUFACTURERS

- A. The following list of manufacturer products that are acceptable for this section, subject to conformance with the specified requirements, are: Warminster Fiberglass, Plasti-Fab A Division of Ershigs, or equal. All fiberglass baffles and weir plates shall be the product of one manufacturer.

### PART 2 -- PRODUCTS

#### 2.01 MATERIALS

- A. All weir plates, scum baffle plates, butt plates, cover plates, washers and scum baffle supports shall be fiberglass reinforced polyester plastic molded by the matched-die method to product uniform, smooth surfaces. A "low profile" resin system shall be used to ensure that all surfaces shall be smooth, resin rich, free of voids and porosity, without dry spots, exposed glass, crazes or unreinforced areas to provide increased corrosion and weather resistance. All edges shall be sealed in the mold. Resin shall be Isophthalic Polyester Fire Retardant (ISOFR) suitable for use in submerged waste treatment applications.
- B. Laminate shall contain a glass content of 30±2 percent using Type "E" glass with chrome or silane finish. Powdered reinforcements shall consist of 47.5 + 1 percent of resin mixture. Final laminate thickness shall be within ±10 percent of the nominal specified thickness. Ultraviolet absorbers shall be added to the resin to prevent deterioration from sunlight. Where weir plates are of nonstandard length or nonstandard mounting hole configuration, such machined or cut edges shall be resin sealed with seal mix.
- C. All items shall be manufactured in accordance with ASTM D2996 and ASTM D3917. The manufacturer shall maintain a continuous quality control program and shall, upon

request, furnish the ENGINEER with certified test reports consisting of physical tests of samples to verify that the laminate has the following minimum physical properties:

<u>Requirement</u>	<u>Minimum Results</u>	<u>Test Method</u>
Tensile Strength (psi)	14,000	ASTM D638
Flexural Strength (psi)	25,000	ASTM D790
Flexural Modulus (psi)	1.0 x 10 <sup>6</sup>	ASTM D790
Impact, Notched, Izod, (foot pound per inch)	15.0	ASTM D256
Barcol Hardness	Minimum, Avg. 40	ASTM D2583
Water absorption, (%/24 hours)	0.1	ASTM D570
Average coefficient of thermal expansion (inch per inch per °F)	10.5 x 10 <sup>-6</sup>	ASTM D696

- D. Procedure used in determining the above properties shall be in accordance with the ASTM Standards, Part 35, using the method designated above. Hardness tests shall be made on the resin rich surfaces of the test samples. Test coupons shall be prepared in accordance with the appropriate ASTM test method.
- E. When it is necessary to adjust lengths of weir plates or scum baffle plates so that they are nonstandard, all machined or cut edges thus exposed shall be polyester resin sealed.

## 2.02 WEIR PLATES

- A. Weir plates shall be ¼-inch nominal thickness and blue-green in color. Each weir plate will be 11-7/8 inches high with notches 2-7/8 inches deep x 90° on 4-inch centers for Clarifier No. 3. Each weir plate will be provided with 2-1/2 square mounting holes at 12 inches on center to provide a minimum 2-inch vertical or horizontal adjustment. Weir plates shall be secured to the wall with ½-inch diameter 316 stainless steel anchor bolts and 5-inch minimum diameter fiberglass reinforced plastic washers to prevent short circuiting. Ends or weir plates shall be secured with 6-inch x 11-7/8-inch high lap plates, fabricated to the specific shape of the concrete troughs (launders), arranged to allow for horizontal expansion. All stainless steel anchor bolts and plastic washers required for installation shall be furnished by the FRP Supplier.

## 2.03 SCUM BAFFLE PLATES

- A. Scum baffle plates shall be ¼-inch nominal thickness and turquoise in color. Baffle plates will be 12 inches high and provided with mounting holes as required to attach to the support brackets. Lengths shall be made to suit the tank, but lengths shall not exceed 10 feet.
- B. Lap plates 6 inches x 12 inches shall be provided to secure the ends of the baffle plates. Type 316 stainless steel hardware shall be furnished by the FRP supplier to secure the



baffle plates to 316 SS support brackets and to lap plates. Type 316 SS anchor bolts shall be used for anchoring scum baffle supports to the wall.

- C. Scum baffle support brackets shall be made from fiberglass reinforced polyester resin and shall be installed at 36 inches on center. Brackets will be minimum 3/16-inch thick, a minimum of 4 inches wide and slotted to allow for at least 1-1/2-inch vertical and horizontal adjustment. The upper brackets shall be minimum 1/2-inch thick and "L" shaped. Type 316 stainless steel anchor bolts at 36 inches on center shall be furnished by the CONTRACTOR.

## PART 3 -- EXECUTION

### 3.01 INSTALLATION

- A. Weirs, baffles and troughs shall be installed under this Contract in full accordance with the manufacturer's recommendations and shop drawings by mechanics skilled in the installation of this type of work and under the supervision of the manufacturer's representative.
- B. Joints between weir plates and concrete and butting weir plates shall be reasonably tight. The CONTRACTOR shall caulk all joints as directed by the ENGINEER where leakage is excessive, with a sealant material as specified in the Section entitled, "Sealants and Caulking".
- C. Bolt protrusions shall be minimized. Bolts/studs which attach the weir scum baffle shall not protrude more than 1/4-inch past the nuts.
- D. The horizontal distance between the scum baffle and the effluent troughs shall be a minimum of eight (8) inches.

- END OF SECTION -

SECTION 06650 – DENSITY CURRENT BAFFLES  
(ALTERNATE BID ITEM)

PART 1 - GENERAL

1.01 THE REQUIREMENT

- A. As part of the Base Bid, the CONTRACTOR shall perform all work necessary to bring Clarifier No. 3 to a fully operable system, including removal and re-installation of existing equipment, per the Contract Documents. At the CITY's option under an Alternate Bid Item, the CONTRACTOR shall furnish and install fiberglass reinforced plastic density current baffles along with all support brackets, fasteners, anchors and other incidental work as shown on the Contract Drawings for Clarifier No. 3.
- B. The final installation shall be complete in all respects and the CONTRACTOR shall be responsible for minor details and any necessary special construction not specifically included in the drawings or specifications.

1.02 QUALITY ASSURANCE

- A. General. The CONTRACTOR shall furnish certified test reports of the physical and mechanical properties of the product. Each panel shall have the minimum physical properties specified herein. Flexural properties shall be measured with the resin-rich upper surface in compression. Hardness tests shall be made on the resin-rich upper surface.
- B. Standards
  - 1. ASTM – American Society for Testing Materials

<b>Method</b>	<b>Test</b>	<b>Minimum Value</b>
ASTM D-638	Tensile Strength	5,000 psi
ASTM D-790	Flexural Strength	16,000 psi
ASTM D-790	Modulus of Elasticity	800,000 psi

- 2. Rockwell – Rockwell Laboratories

<b>Method</b>	<b>Test</b>	<b>Minimum Value</b>
Rockwell	Hardness	R15T 65

- C. All fiberglass items of the same type provided shall be the products of a single manufacturer for compatibility.
- D. The equipment manufacturer shall furnish a list of five (5) installations of similar size that have been in continuous operation for a minimum of three (3) years.

#### 1.03 SUBMITTALS

- A. Submit manufacturer's technical data and application instructions.
- B. In accordance with Section entitled "Submittals", shop drawings shall show dimensional layouts, materials of construction, bill of materials, bolt and anchor locations, fittings and accessories and shall be based on field measurements by the CONTRACTOR as he deems necessary to ensure a conflict and trouble-free installation. Fabrication shall be in accordance with the shop drawings.
- C. The manufacturer shall submit calculations confirming that the baffle is capable of withstanding the unbalanced force acting from underneath the baffle, which is assumed equal to the full buoyancy. The calculation shall be prepared, signed, dated and sealed by a registered professional engineer.
- D. The baffle manufacturer shall warrant that all materials furnished by him shall be free of defects in materials and workmanship for a period of five (5) years from the date of acceptance.

#### 1.04 JOB CONDITIONS

- A. Coordinate all work with other trades to prevent delays, errors and/or omissions.

#### 1.05 DELIVERY, STORAGE AND HANDLING

- A. The CONTRACTOR shall store materials indoors and protect from construction traffic and damage.

### PART 2 - PRODUCTS

#### 2.01 DENSITY CURRENT BAFFLES

- A. The density current baffle system shall consist of a series of baffle panels that are attached to the wall of the clarifier to form an inclined, shelf-like surface around the inner periphery of the tank. Panels shall be designed to fit between trough supports. Each panel shall be molded of corrosion-resistant, uv-treated fiberglass. The panel shall be a maximum of eight feet in length and shall be curved to follow the curvature of the clarifier tank. Each panel shall be inclined at a 45-degree angle from the tank wall. The panels shall be designed such that adjacent panels fit together without overlapping or cutting, and the completed baffle, when installed, has a well-engineered and professional appearance.
- B. Provision shall be made to attach the panels to the clarifier wall and support them at the proper angle using a triangular panel bracket. The panel bracket shall be molded as an

integral part of each panel, forming a baffle module, or separate panels and brackets may be supplied. If the panel and bracket are molded as an integral unit with adequate stiffeners, only one bracket is required per panel. A specially formed "free-end" bracket shall be provided to support the free-end of the panel at the trough supports or where the run of panels is interrupted by an obstruction. No modifications to the panels shall be made without the written approval of the ENGINEER.

- C. If separate panels and brackets are supplied, the panels shall be molded of fiberglass and shall meet the specifications of this section. The brackets shall be fabricated of 3"x3"x1/4" Type 304 stainless steel angle and shall be triangular in shape, with the corners welded. Brackets shall be installed at a maximum spacing of four (4) feet. The panels shall be fastened to the brackets with stainless steel nuts, bolts and lock washers every 8 inches.
- D. A method of interconnecting adjacent panels shall be provided such that the entire assembly forms a rigid structure capable of supporting its own weight plus wind loads in the event the tank is out of service. The baffle shall also be designed to withstand a buoyant force load equal to the weight of the water displaced from the volume beneath the baffle and shall resist flotation in the event gas builds beneath the panel. The angled working surface of each baffle shall be sufficient in pitch and width to divert the flow and to create a self-cleaning action of the baffle itself. Provision shall also be made to vent gasses that may form beneath the baffle through the installation of vents located in the panel. Vents shall be formed in at the time of panel fabrication.

## 2.02 COMPONENTS

- A. Each baffle panel shall be molded of fiberglass-reinforced plastic. The resins and fiberglass reinforcing material shall be compatible with the environmental conditions and structural requirements.
- B. The resin shall be an isophthalic polyester resin with corrosion-resistant properties, 33-402 resin or equivalent, suitable for use in submerged waste treatment applications. The resin shall not contain fillers except as required for viscosity control. For viscosity control, a thixotropic agent up to 5 percent by weight may be added to the resin. The resin shall be treated to provide ultraviolet suppression.
- C. Glass reinforcement shall consist of chemically bonded surfacing mat and chopped strand roving. Surfacing mat shall be Type C veil. The glass reinforcement shall be 357-211 PLN CTC chopped strand roving or equivalent. The glass content of the finished laminate shall not be less than 30 percent by weight. The nominal thickness of each baffle panel shall be a minimum of 1/4-inch thick with resin rich surfaces and edges to prevent migration of moisture and fiber "blooming". The baffle shall be black in color.
- D. The upper surface of each panel shall be mold smooth and no glass fibers shall be exposed. Laminations shall be dense and free of voids, dry spots, cracks or crazes. The upper surface of the baffle shall be reinforced with one layer of surfacing veil followed by 2 ounces or more of chopped strand roving. No other glass product is permitted between these layers. All factory-trimmed edges shall be "hot coated" with resin to prevent wicking.

- E. When it is necessary to adjust lengths of baffle panels so that they are nonstandard, all machined or cut edges thus exposed shall be polyester resin sealed.
- F. The density current baffle system shall be as supplied by, Warminster Fiberglass Company, Plasti-Fab A Division of Ershigs, or equal.

### PART 3 - EXECUTION

#### 3.01 INSTALLATION

- A. The CONTRACTOR shall field verify existing dimensions and install the baffle in accordance with the contract drawings, approved shop drawings and manufacturer's recommendations. Mounting holes shall be factory drilled. Field cutting of baffle panels will be allowed to complete the structure and accommodate in-tank obstructions. All field cut or drilled edges shall be coated per the manufacturer's recommendations to prevent fiber blooming or fraying. The fastening system for the baffles shall be designed and provided by the manufacturer. All of the installation fasteners shall be 316 stainless steel.
- B. The density current baffle shall extend completely around the tank and shall be level, rigid and free of sway that could work anchors loose or cause undue wear.

- END OF SECTION -

SECTION 11232 - FINAL CLARIFIER MECHANISM REPLACEMENT  
(ALTERNATE BID ITEMS)

PART 1 -- GENERAL

1.01 THE REQUIREMENT

- A. As part of the Base Bid, the CONTRACTOR shall perform all work necessary to bring Clarifier No. 3 to a fully operable system, including removal and re-installation of existing equipment, per the Contract Documents. At the CITY's option under Alternate Bid Items, the CONTRACTOR shall furnish, install, test, and place in acceptable operation, a new 135-foot diameter clarifier mechanism complete with sludge and scum collection system for existing Clarifier No. 3, as described herein and as shown on the Drawings.
- B. At the CITY's option, under Alternate Bid Item A-1, the equipment furnished for Clarifier No. 3 shall include: full-diameter walkway with handrails, center drive platform and grating, clarifier mechanism center assembly with drive unit, drive control, torque limiting system, control panels, stationary influent column (center column) with suitable upper inlet openings, neoprene seals, feedwell with steel base and seal around the center ring, center cage, sludge removal arms (rake arms) with blades and squeegees, sludge drawoff pipes, sludge collection drum with control valves, scum skimmers and supports, scum box, and scum spray system including spray nozzles, piping, and valve replacement, with solenoid valves and limit switches. All ferrous metals shall be coated in accordance with Section 09900. Materials specified in Section 11232 herein shall refer to the equipment furnished for a new 135-ft diameter clarifier mechanism, except where explicitly indicated in Paragraph 1.01(C) under Alternate Bid Item A-2.
- C. At the CITY's option, Alternate Bid Item A-2 is for complete clarifier mechanism replacement at Clarifier No. 3, as detailed in Alternative Bid Item A-1 (above); however, the following clarifier mechanism equipment components shall be furnished in 316 stainless steel: full-diameter truss walkway, center drive platform, center column and associated flanges and influent ports, feedwell and associated bottom plate and influent tubes, center cage, rake arms, rake blades, sludge collection drum, skimmer assemblies and scum box.
- D. At the CITY's option, under Alternate Bid Item A-3, the CONTRACTOR shall furnish and install new effluent weirs and scum baffles at Clarifier No. 3.
- E. At the CITY's option, under Alternate Bid Item A-4, the CONTRACTOR shall furnish and install new density current baffles at Clarifier No. 3.
- F. The clarifier equipment provided shall be the full and undivided responsibility of a single manufacturer who shall confirm compatibility of his equipment with the existing clarifier equipment and ensure complete coordination of all components and provide unit responsibility. Alternate Bid Items A-3 and A-4 shall be the responsibility of the FRP supplier.
- G. Except where specifically indicated otherwise, all plates and structural steel shall have a minimum thickness of ¼" and coated as described in Division 9 and as shown on the Drawings and Shop Drawings. Minimum thickness for 316 stainless steel plates and

structural steel shall be 3/16" (corrosion allowance not needed). All fasteners for the mechanism shall be 316 stainless steel.

- H. All equipment installed in classified areas shall be suitable for the environment. Refer to electrical drawings for hazardous area classifications.

#### 1.02 RELATED WORK SPECIFIED ELSEWHERE

- A. Section 01010 – Summary of Work
- B. Section 01300 – Submittals
- C. Section 03732 – Concrete Repair
- D. Section 05500 – Metal Fabrications
- E. Section 06620 – Scum Baffles and Weir Plates
- F. Section 06650 – Density Current Baffles
- G. Section 07920 – Sealants and Caulking
- H. Section 09900 – Painting
- I. Section 11000 – Equipment General Provisions
- J. Section 15000 – Basic Mechanical Requirements
- K. Division 16 – Electrical
- L. Division 17 – Instrumentation

#### 1.03 GENERAL INFORMATION AND DESCRIPTION

- A. All parts of the mechanism furnished shall be amply designed and constructed for the maximum stresses occurring during fabrication, erection and continuous operation. All materials shall be new and both workmanship and materials shall be of the very best quality, entirely suitable for the service to which the units are to be subjected and shall conform to all applicable sections of these specifications. All parts of duplicate equipment shall be interchangeable without modification. Manufacturer's design shall accommodate all the requirements of these specifications.
- B. Clarifier No. 3 is of the center column bottom inlet feed and peripheral overflow type with a central driving mechanism, which supports and rotates a center cage with two rakes attached.
- C. The equipment shall be of sufficient structural and mechanical strength to sweep in the two-inch grout layer on the tank bottom under its own power. (This does not mean utilizing the clarifier arm for spreading the concrete.) The mechanism shall be arranged for scraping blades and sludge withdrawal pipes along the length of the rake arms for rapid removal of sludge. Deflector blades with squeegees shall be attached to the bottom of the

arms in a "V" notch pattern to guide the sludge to the openings of the withdrawal pipes along the arms and will sweep the entire floor on each revolution of the collector arm as shown on the drawings.

- D. The clarifier mechanism shall be designed and furnished with no chains, sprockets, bearings or operating mechanism below the liquid surface or in contact with the liquid. Peripheral or traction drive mechanisms will not be regarded as equal to the center drive mechanisms specified. Major pieces of equipment, such as the drive and center well are to be assembled in the shop to ensure proper fitting of parts, marked with erection marks and knocked down for shipment.

#### 1.04 MANUFACTURERS

- A. The materials covered by the Specifications are intended to be standard equipment of proven reliability and as manufactured by reputable manufacturers having experience in the production of such equipment. The equipment furnished shall be designed, constructed, and installed in accordance with the best practices and methods and shall operate satisfactorily when installed as shown on the Drawings and operated per manufacturers recommendations.
- B. The clarifier mechanism shall be as manufactured by Ovivo USA, Westech Engineering, or equal.

#### 1.05 SUBMITTALS

- A. The CONTRACTOR shall submit shop drawings and Operation and Maintenance Instructions and other information as specified in accordance with Section entitled, "Submittals." Additional required information should include: the horsepower, voltage, and rotative speed of the motor and the total weight of the equipment plus the approximate weight of the shipped materials, and hydraulic calculations for the rapid sludge withdrawal system. Shop Drawings shall also include complete erection, installation and adjustment instructions and recommendations, and detailed test procedures for the field testing specified herein.

#### 1.06 OPERATION AND MAINTENANCE MANUALS

- A. The CONTRACTOR shall submit operation and maintenance manuals in accordance with the procedures and requirements set forth in Section entitled, "Submittals."
- B. Two copies of a preliminary O&M manual shall be included in the shop drawings submittal. Without inclusion of these manuals, the submittal will be considered incomplete and will be returned without review.

#### 1.07 SERVICES OF MANUFACTURER'S REPRESENTATIVE

- A. The CONTRACTOR shall provide the services of a qualified manufacturer's technical representative who shall adequately supervise the installation and testing of all equipment furnished under this Section and instruct the CITY's operating personnel in its maintenance and operation as outlined in the General Conditions and Division 1. The services of the manufacturer's representative shall be provided for a period of not less than four days as follows:



1. One two-day trip during the installation of Clarifier 3.
  2. One one-day trip for start-up and training of CITY staff.
  3. One trip of one day after acceptance of the equipment, during the guarantee period, at CITY's request.
- B. Any additional time required to achieve successful installation and operation shall be at the expense of the CONTRACTOR.

#### 1.08 TOOLS, SUPPLIES AND SPARE PARTS

- A. The equipment manufacturer shall furnish all special tools necessary to disassemble, service, repair, lubricate, and adjust the equipment. A complete list of tools and instructions for their use recommended by the manufacturer shall be submitted with the Shop Drawings.
- B. The CONTRACTOR shall furnish a one-year's supply of all recommended lubricating oils and grease.
- C. Spare parts shall be furnished as recommended by the manufacturer and shall be identical to and interchangeable with original parts. As a minimum, the following spare parts shall be provided:
- a. One (1) set of neoprene seals for Clarifier No. 3.

#### 1.09 WELDING

- A. The Equipment Manufacturer's shop welding procedures, welders and welding operators shall be qualified and certified in accordance with the requirement of AWS D1.1 "Welding In Building Construction" of the American Welding Society.
- B. The Equipment Manufacturer's shop drawings shall clearly show complete information regarding location, type, size and length of all welds in accordance with "Standard Welding Symbols" AWS A2.0 of the American Welding Society. Special conditions shall be fully explained by notes of details.
- C. The CONTRACTOR's welding procedures, welders and welding operators shall be qualified and certified in accordance with the requirements of AWS D1.1 "Welding in Building Construction" of the American Welding Society.
- D. The CONTRACTOR shall perform all field welding in conformance with the information shown on the Equipment Manufacturer's drawings regarding location, type size and length of all welds in accordance with "Standard Welding Symbols" AWS A2.0 of the American Welding Society, and special conditions as shown by notes and details.

PART 2 -- PRODUCTS

2.01 GENERAL

- A. The design criteria of equipment to be furnished and installed under this section are as noted on Table 11232-1:

**Table 11232-1**

<b>Item</b>	<b>Clarifier Design Criteria</b>	
	<b>Clarifier No. 3</b>	
Number of Units	1	
Identification Numbers		
Inside Tank Diameter, ft	135	
Side Water Depth, ft	14.2	
Tank Bottom Slope, in/ft	1/16	
<u>Center Drive Mechanism:</u>		
Continuous Torque, ft-lb	62,000	
Design Torque (motor shutdown), ft-lb	75,000	
Momentary Torque, (peak) ft-lb	150,000	
Rake Arms Tip Speed, fpm (Max.)	10	
Cage and Arm Design, ft-lb	150,000	
Motor Horsepower Minimum, Hp	1.5	
Hydraulic Capacity of Rapid Sludge Pick Up System (gpm/tank of 0.5 to 3.0% pure oxygen activated sludge)	6,600	

- B. The manufacturer shall furnish calculations and a written statement certifying that the drive selected meets the output torque including all gears and pinions in the drive train and the other requirements specified herein.
- C. Structural steel used in fabricated parts shall conform to requirements of "Standard Specifications for Steel for Bridges and Buildings" ASTM Designation A36. All shop welding shall conform to the latest standards of the American Welding Society.
- D. All anchor bolts, washers, clips, clamps and fasteners of any type shall be constructed of Type 316 Stainless Steel.

2.02 CENTER COLUMN AND CAGE

- A. A cylindrical steel center column shall be furnished for mounting over the influent port at the center of the tank floor to support the mechanism with no torque transmitted to the walkway. The center column shall have a minimum inside diameter of 54 inches with a port area of adequate size to secure a low inlet-velocity into the influent well. Anchor bolts for Clarifier No. 3 shall be adhesive type. The manufacturer shall furnish the sufficient number of anchor bolts required for the torque load and for securing the center column on the concrete floor. Steel thickness of column shall be a minimum of 1/2 inch for Alternate Bid Item A-1 and 3/8 inch for Alternate Bid Item A-2.

- B. Two sets of ports shall be included at the upper end. One set of upper ports shall convey the fresh sludge from the overflow boxes to the central discharge pipe. The lower set of ports shall diffuse the flow entering the tank and insure low velocity into the influent well. The lower ports total opening area shall be a minimum of 135 percent of the influent pipe cross sectional area. Upper and lower ports shall be separated by a neoprene seal with steel backing ring.
- C. A steel center cage shall be bolted to the internal gear and shall be sufficiently strong and stiff to support and rotate the rake arms.

### 2.03 CENTER DRIVE MECHANISM

- A. The center drive mechanism shall be designed for the specified design torque on the internal gear without excessive wear. The mechanism shall be capable of developing the specified momentary torque on the internal gear without failure of any part.
- B. The center drive mechanism shall consist of a turntable base mounted on the center column, a ball race, a turntable top with internal gear with pinion, and cycloidal or worm gear reduction unit. The turntable base and top shall be heat-treated, high grade Type GC, ASTM A48 Mechanite cast iron alloy, ASTM A36 steel, or acceptable equal for Alternate Bid Item A-1 and ASTM A48 Mechanite cast iron alloy or ASTM A276 for Alternate Bid Item A-2. The top of the turntable base shall provide adequate and convenient access to the drive mechanisms for proper maintenance.
- C. The turntable base shall be bolted to the center column and be designed to support the internal gear with the rotating mechanism and the walkway. Welded steel construction will be permitted. The turntable base shall have an annular raceway to contain balls upon which the internal gear rotates. The ball race shall have a minimum diameter of 65 inches to assure stability without the necessity of underwater guide shoes.
- D. The ball race shall contain a minimum 1-1/2 inch diameter balls made of chrome alloy steel AFBMA Grade 500. The balls shall bear vertically and horizontally on four renewable steel liner strips fitted into the turntable base and internal gear or utilize full contour raceways. The strip liner design shall be such that the B-10 life of the liner is a minimum of 20 years based on the specified mechanism speed and a uniformly distributed load on the rotating mechanism. Drives using integral bearing and gear assemblies must have replaceable bearing balls and, if applicable, replaceable liners, if used, independent of the gear, without removing the gear.
- E. The balls shall run in an oil bath or be grease packed and protected by suitable seals. A sight gauge shall be provided for observation of oil level. All oil dams in the drive shall be full sidewall integral with the base and have a minimum of 4-inch deep oil storage and condensation reservoir below the bottom of the bearing assembly. Housing shall be designed such that gears and bearings are properly lubricated. For spur gear teeth, which are not fully submerged in oil, the tooth mesh shall be designed to force lubricant to the upper portion of the tooth face.
- F. An oil sight glass shall be provided for the upper and lower oil reservoirs. Readily accessible lubricant fill and drainpipes of Type 316L Stainless Steel fittings shall be provided. Lubricant systems that require auxiliary oil pumps or recirculating systems will not be acceptable.

- G. The internal gear shall also be machined from a high-grade cast iron or other approved metallurgy and shall be designed to support the center cage and rake arms. The internal gear shall be driven by a heat treated metal pinion and shaft keyed to the drive unit primary reduction unit mounted on the turntable base.
- H. At continuous torque, the gear teeth shall not be stressed to more than 30 percent of their yield strength.
- I. The drive head bearing shall be related for the total rotating weight. The bearing shall have minimum B-10 life rating of 20 years.

#### 2.04 DRIVE UNIT

- A. The drive unit shall be secured to the turntable base and shall consist of a worm, and worm gear or cycloidal speed reducer, and a pinion mounted in a cast Mechanite metal or cast iron housing with a removable stainless steel cover plate. Directly coupled cycloidal reducers shall also be acceptable.
- B. The worm and worm shaft shall be cast as an integral unit and shall be heat treated steel (ASTM 4142N) or alloy steel (AISI 8620 or AISI 4140/42 H) with the worm threads surface hardened and finish ground or carbonized, hardened, ductile iron minimum Grade 80. The worm gear shall consist of a worm gear rim and hub. The worm gear rim shall be a cast Mechanite metal type GM60 (ASTM A48) or centrifugally cast bronze. The worm gear rim shall be replaceable without disassembly of bearings.
- C. The worm and worm gear shall operate in an oil bath. A sight gauge shall be provided for observation of the oil level.
- D. The pinion and pinion shaft shall be cast as an integral unit and shall be alloyed nodular iron, Grade 80-60-04 (ASTM A536) heat-treated and with hardened teeth or 41L47 AISI forged steel 220-266 BHN. The pinion shaft shall be keyed to the worm gear spider and the pinion shall mesh with and rotate the internal gear.
- E. Bearings supporting the worm, worm gear and the pinion shall be precision tapered roller bearings and shall operate in an oil bath. The lower pinion shaft bearing shall be grease lubricated or the bearings, including the shaft bearings shall operate in an oil bath. An acceptable alternative for the bearings supporting the worm, worm gear and pinion, shall be a deep groove ball bearing SKF-62 or 63 for worm input, upper pinion, angular contact ball bearing SKF-73 for the worm thrust bearing, and cylindrical roller bearings SKF-N3 for the lower pinion. The lower pinion-bearing pocket shall not be lower than the oil dam of the main gear base. All oil dams in the drive shall be full sidewall integral with the base and have a minimum of four-inch deep oil storage and condensation reservoir below the bottom of the bearing assembly. Housing shall be designed such that gears and bearings are oil lubricated.
- F. The complete drive shall be designed for the continuous torque specified based upon 24 hour per day over 20 years using two criteria established per 2001-C95 spur gear and pinion and AGMA 440.02 worm and worm gear design.

- G. The cycloidal speed reducer shall be directly connected to the motor without the use of chains or v-belts, and shall be keyed to the pinion. The main ring gear of the cycloidal drive shall be made of high carbon chromium bearing steel. The speed reducer gearing shall be manufactured to AGMA standards and have a service factor of 1.25.

## 2.05 ELECTRIC MOTORS

- A. The clarifier drive unit is driven by a drive motor. The drive motor shall be minimum 1 ½ hp. The motor shall be TEFC chemical service and shall be 460 V, 60 Hz, 3 phases A.C. Motor shall comply with the applicable portions of Section entitled, "Electric Motors."

## 2.06 OVERLOAD DEVICES

- A. The CONTRACTOR shall furnish and install new overload device as part of the clarifier drive unit replacement. The overload device shall be actuated by the shaft and shall indicate the load on the center drive mechanism at all times. The overload device shall have a minimum of two torque switches, one adjusted to actuate when the load on the mechanism approaches an overload; the other to open the motor circuit when an excessive overload occurs. The two torque switches shall be preset at the factory to provide remote indication at 85 percent of the design torque and to stop the motor at the momentary torque. Torque switches shall be DPDT, 120 VAC, 5 amp, continuous rating.

## 2.07 INFLUENT FEEDWELL

- A. The influent well at Clarifier No. 3 shall be 26 feet in diameter and project 7 feet below the water level and 6 inches above the maximum clarifier water level and shall be made of minimum ¼-inch steel for Alternate Bid Item A-1 or 3/16-inch stainless steel plate for Alternate Bid Item A-2 with ¼-inch stiffening angles and provided with at least eight 4" x 16" baffled slots equally spaced at water level to permit escape of floating material. Each slot shall be provided with steel plate and connectors to permit blocking of the openings. The bottom of the influent feedwell shall be supplied with a solid reinforced steel bottom and a seal around the center column similar to the seal specified for the rotating sludge discharge well. The influent feedwell shall be coated as described in Division 9.
- B. The feedwell shall be equipped with a scum wedge skimmer assembly. The scum wedge skimmer shall include a rotating skimmer arm fixed between the rotating feedwell and cage tangentially in front of a scum port just in front of the rotating skimmer. The cage shall be fitted with a fixed support constructed of pipe and angle frame with a minimum 12-inch skimmer skirt. Scum shall be wedged along the skimmer bar and forced out into the area between baffle and feedwell.

## 2.08 ROTATING RAKE ARMS

- A. Two structural steel arms of box truss construction conforming to the slope of the tank floor shall be rigidly bolted to the center cage without the use of supporting guy or tie rods and shall be provided with 1/4-inch steel bolted rake blades to scrape the settled sludge on the tank bottom to the sludge drawoff pipes.
- B. Rake arms for Clarifier No. 3 shall be shipped in two pieces and field assembled. Blades may be field mounted. The blade setting shall be identical for each arm with the blades so spaced in a "V" notch pattern such that each pickup pipe removes sludge from equal

surface areas of the tank bottom and that the entire tank bottom is scraped twice for each revolution of the mechanism. Adjustable stainless steel squeegees shall be furnished for all blades and they shall project 1-1/2 inches below the bottom of the blade and shall be secured by Type 316 Stainless Steel bolts and nuts.

- C. Dissimilar materials shall be properly isolated. The rotating rake arms shall be coated as described in Division 9.

## 2.09 RAPID SLUDGE WITHDRAWAL COMPONENTS

- A. Clarifier No. 3 shall be provided with six 10-inch diameter withdrawal pipes on each rake arm. Sludge withdrawal pipes shall be Schedule 80 PVC type 1, grade 1 ASTM 3034. Elbows with fair curves for change of direction shall be provided as required. PVC pipe shall be arranged for easy assembly with minimum trimming. For Clarifier No. 3, the maximum total sludge returned shall be 6,600 gpm. The withdrawal pipes shall be attached to the rake arms at their lower end by means of Type 316 Stainless Steel clamps and shall pass through the arms and vertically upward to the rotating sludge discharge well.

## 2.10 ROTATING SLUDGE DISCHARGE WELL (SLUDGE COLLECTION DRUM)

- A. A rotating sludge discharge well (sludge collection drum) shall be provided and shall be constructed of 1/4-inch steel plate, assembled around the center cage and extend through the cage to the center column. A suitable neoprene seal shall be provided between the rotating discharge well and the stationary center column. The seal elements shall provide easy adjustment for assembly and maintenance. The seal shall accommodate eccentric vertical variation in alignment. The main seal element shall be constructed of carbon steel ring welded to the center column with a continuous carbon steel ring welded to the sludge wet well. A hard rubber seal, studded to the sludge box well ring shall be installed across the seal opening. The top of the box shall be the same height as the influent feedwell. The discharge well shall be centrally located within the influent well and shall be arranged to convey the sludge from the withdrawal pipes to the central discharge pipe. The discharge well shall be coated as described in Division 9.

## 2.11 SLUDGE OVERFLOW CONTROL DEVICE

- A. The upper end of each sludge withdrawal pipe shall be provided with an overflow control device in the discharge well. The control device shall be adjustable to positively control the flow of sludge from each withdrawal pipe. The overflow control device shall essentially be an adjustable port and shall consist of a stationary inner pipe and a rotating outer pipe. The inner pipe shall be flanged at the lower end for mounting on the bottom of the discharge well and for bolting to the flange of sludge withdrawal pipe and shall be provided with a vertical rectangular slot. The outer pipe shall fit snugly over the inner pipe and shall be provided with a trapezoidal opening. The openings shall be superimposed over one another and the effective opening area shall be variable by rotating the outer pipe. An indicator shall be provided for each overflow control for determining the effective opening in the device. The outer pipe shall be removable in order to have the full inner pipe diameter clear for back flushing when required. Each control device shall be fabricated from ASTM D3034 PVC piping, with a minimum 3/8-inch thick top and bottom flanges. The devices shall be assembled using approved PVC welding. Solvent welded assembled is

not acceptable. All mounting clips and bolts for the sludge control devices shall be 316 stainless steel.

- B. The ports shall be operated submerged up to the maximum flow of 6,600 gpm/tank for Clarifier No. 3 so that flow rate may be controlled by differential water level by throttling the return sludge discharge line from the tank. A tool for adjusting the overflow control devices from the walkway shall be provided. Overflow control devices using a telescopic valve arrangement are not acceptable. A maximum head loss from the clarifier water surface at maximum sludge flow shall not exceed ten inches in the sludge box.

## 2.12 SCUM SKIMMERS, SKIMMER SUPPORTS AND SCUM BOXES

- A. The manufacturer shall furnish skimmers and compatible scum box for Clarifier No. 3. Clarifier No. 3 shall be furnished with two skimming devices to collect the floating scum along the interior edge of the collection trough where it shall be automatically deposited in one scum box. Each of the two skimming devices shall be supported from each rake arm and shall consist of a 1/2-inch thick neoprene skimming blade (approximately 72" x 18") installed on the fixed skimmer arm with a 2-inch diameter stainless steel pipe section.
- B. One 6-foot wide scum box for Clarifier No. 3 shall be adequately supported from the effluent trough wall and connected to the scum drain system through an 8-inch diameter scum pipe as shown on the Drawings. The box shall be made of welded 1/4-inch 316 stainless steel plate, to serve as an integral section of the tanks scum baffle. The assembly shall have a scum trough, vertical steel sides, sloping ramp, and 8-inch diameter straight pipe stub for connection of a flexible connector to interface with scum outlet piping.

## 2.13 ACCESS BRIDGE AND PLATFORM

- A. Clarifier No. 3 shall have an access bridge spanning the full diameter of the tank, as shown on the Drawings. At the center of the clarifier mechanism, a platform with hand railing and kick plate shall be provided. The center drive platform shall have removable 1-1/2 inch I-bar aluminum grating for access to the drive mechanism.
- B. The walkway support structural members shall be all welded, truss construction, with diagonal and cross bracing as necessary, and shall be 316 stainless steel after fabrication. The flat portion of the channel shall be located on the outface of the walkway to support handrails, light poles and appurtenances. Walkways shall be aluminum checkered plate.
- C. The access bridge and platform shall be designed for a live load of 100 pounds per square foot and a maximum deflection of 1/360. The walkways shall be a minimum of three feet wide.
- D. The CONTRACTOR shall design and furnish materials for the walkway connection to the outer concrete wall. The connection shall provide for expansion and contraction of the walkway from temperature by use of stainless steel UHMW-PE self-lubricating plate bearings. A means shall be provided to prevent lateral movement of the bridge at the outer wall. Walkways shall be designed to support light poles and fixtures as shown on the Drawings. The 10-inch by 10-inch (minimum) 90 degree light pole supports shall be supplied and installed by the clarifier Supplier, subject to review and comment of the ENGINEER.

- E. Drive platforms shall consist of a 316 stainless steel frame with 1-1/2 inch I-bar aluminum grating designed to support a live load of 100 pounds per square foot and provided with stiffener angles as required to meet the design load with a maximum deflection of l/240.
- F. Handrailing, checkered plates and kick plates shall be aluminum as specified in the Division entitled "Metals." Metallic steps, as required to meet local code requirements, shall be furnished between the structure and the access bridge, as required.
- G. All dissimilar metals shall be properly isolated.

2.14 STRUCTURAL STEEL

- A. All material used in fabricating structural steel shall be new and undamaged. All materials shall conform to applicable provisions of the AISC Specifications for the design and fabrication of structural steel, AWS Welding Specification and to pertinent ASTM Standard Specification including the following:

<b>Material</b>	<b>ASTM Standard Specifications For</b>	<b>ASTM Designation</b>
Structural steel not welded	Steel for bridges and buildings	ASTM A276
Welded structural Steel	Structural steel for welding	ASTM A276
Cast iron	Grey iron castings	A-48
Machine bolts	Low carbon steel fasteners	Grade 5 A537 High Strength
316 Stainless steel	Plates and sheets	ASTM A167 or A666 Grade A
316 Stainless steel	Structural shapes	ASTM A276

2.15 EFFLUENT WEIR SCUM BAFFLES AND DENSITY BAFFLES

- A. Comply with requirements set forth in Division 6.

2.16 SPRAY NOZZLES

- A. Spray nozzles shall be constructed of Type 316 Stainless Steel, operate at a pressure of 10 psi and connections shall be 3/8-inch NPT. All nozzles shall be capable of passing a maximum 1/8-inch diameter sphere. Nozzles shall be manufactured by Spraying Systems Co., Bete, Inc., Bex, Lechler, or equal.
- B. Nozzle replacement shall be of the same quantity and location as existing nozzles. Nozzles shall consist of the following types.

<b>Description</b>	<b>Spraying Systems Model No.</b>
Surface Skimmer	3/8 K-40
Scum Boxes	3/8 GG-25
Influent Feedwell	3/8 GG-25



- B. All spray piping, including miscellaneous valves, elbows, unions, drop pipe for nozzles, etc., shall be replaced in-kind at Clarifier No. 3, to the work area limits indicated on the drawings.

## 2.17 CONTROL PANEL

- A. The Clarifier Supplier shall furnish an electrical control panel for Clarifier No. 3 to be mounted on the access bridge handrail, at the location of the existing control panel to be removed and replaced. The panel shall conform to all applicable requirements of Divisions 16 and 17 and the Drawings.
- B. The panel shall include a disconnect switch, Start-Stop and Reset pushbuttons for the rake drive and equipment. Panel shall also include HOA selector switches and reset cycle timers for the scum spray controls. Refer to elementary control schematics for additional controls and equipment requirements.
- C. The panel shall be housed in a NEMA 4X rated 316L stainless steel enclosure and shall be constructed by a UL508A approved panel shop, and shall be furnished with a U.L Label. The panel shall have a hinged and gasketed door. Door latches shall be all stainless steel, fast operating clamp assemblies that do not require bolts or screws to secure.
- D. The panel components shall be connected to the MCC as shown on the Drawings.
- E. Provide "dry contact" relay outputs for the digital (discrete) outputs signals shown on the Instrumentation Drawings.
- F. Control Operator Requirements:
  1. Control operators such as pushbuttons (PB), selector switches (SS), and pilot lights (PL) shall be Cutler-Hammer/Westinghouse Type E34, Square D Company Type SK, or equal. Control operators shall be 30.5 mm, round, heavy duty, oil tight NEMA 4X corrosion resistant.
  2. Pushbuttons shall be non-illuminated, spring release type. Pushbuttons shall include a full guard. Panic stop/alarm pushbuttons shall be red mushroom type with manual-pull release. Selector switches shall be non-illuminated, maintained contact type. Pilot lights shall be of the proper control voltage, LED type with lens colors as indicated on the elementary control diagrams.
  3. Control operators shall have legend plates as specified herein, indicated on the Drawings, or otherwise directed by the Engineer. Legend plates shall be plastic, black field (background) with white lettering. Engraved nameplates shall be securely fastened above each control operator. If adequate space is not available, the nameplate shall be mounted below the operator.
  4. Control operators for all equipment shall be as specified herein and of the same type and manufacturer unless otherwise specified or indicated on the Drawings.
  5. Alarm horns shall be general-purpose type, flush panel mount, suitable for weatherproof service, as required. Volume shall be adjustable.

## 2.18 LIMIT SWITCHES AND SCUM SPRAY CONTROLS

- A. Limit switches shall be furnished and installed on Clarifier No. 3 to indicate position of the clarifier skimmer mechanism relative to the scum box. Switches shall be form Z type, Model 43-100 D as manufactured by General Equipment & Manufacturing Co., or equal. Case shall be hermetically sealed, epoxy coated brass. Switches shall be furnished with mounting brackets and hardware designed to detect passage of the clarifier scum mechanism.
- B. Switch contacts shall be SPDT, 120 VAC, 10 amp, continuous rating.
- C. Each switch shall reset and actuate an adjustable reset cycle timer which shall energize a 120 volt solenoid valve on the scum box spray header and de-energize the solenoid valves after an adjustable time delay (0 - 10 minutes).

## 2.19 SCUM SPRAY SOLENOID

- A. Scum spray solenoids shall be furnished for Clarifier No. 3 by the Clarifier Supplier. Scum spray solenoids shall be 120 VAC, energize to open, spring close, heavy duty, with hand-actuated manual override capability in NEMA 4X enclosure and shall be coordinated with scum spray piping and nozzles. Solenoid valves shall be mounted complete in place and wired to the scum spray controls and control panel.

## PART 3 -- INSTALLATION

### 3.01 ERECTION

- A. All equipment shall be erected by the CONTRACTOR in accordance with the manufacturer's drawings and instructions.
- B. Joints between weir plates and concrete and butting weir plates shall be reasonably tight. The CONTRACTOR shall caulk all joints with sealant material as specified in the Section entitled "Joint Fillers, Sealants and Caulking".
- C. Weirs and scum baffles shall be installed in full accordance with the manufacturer's recommendations by mechanics skilled in the installation of this type of work.

### 3.02 PAINTING

- A. New equipment shall be sandblasted and shop primed, in accordance with Section 09900 – Painting.
- B. Surfaces shall be finish painted in the field, in compliance with Section 09900 – Painting.

### 3.03 TESTING

- A. Field testing of torque capability on the collection mechanisms shall be performed as follows:

1. Static Torque Test

- a. The purpose of the test shall be to verify the structural integrity of the mechanism and drive. Manufacturer shall provide a qualified service person to supervise tests.
- b. The clarifier mechanism shall be field torque tested. The testing shall be carried out under the supervision of the equipment manufacturer before the mechanisms are accepted and placed into operation.
- c. The torque test shall consist of securing the rake arms by cables to anchor bolts installed by the CONTRACTOR in the tank floor at locations recommended by the manufacturer and accepted by the ENGINEER. A torque load shall be applied to the scraper arm by means of a ratchet lever and cylinder connected to the cable assembly.
- d. The magnitude of the applied load shall be measured by calculating the torque from the distance of the line of action of each cable to the centerline of the mechanism. Readings shall be taken at 50 percent, 85 percent, and 100 percent of design torque value. The test load shall be applied and noted on the torque overload device.
- e. The manufacturer's serviceman shall certify that the alarm and motor cut-out torque of the drives as calibrated in the manufacturer's shop are in proper operation to shut down the unit as specified.
- f. All equipment required for the test shall be provided by the CONTRACTOR.
- g. Anchor bolts shall be removed and concrete repaired in accordance with Division 3, at the successful completion of the test.

- END OF SECTION -

**ATTACHMENT D**  
**TECHNICAL SPECIFICATIONS**  
**CITY OF HOLLYWOOD**  
**SOUTHERN REGIONAL WASTEWATER TREATMENT PLANT**  
**CLARIFIER NO. 3 REPAIR**

## TABLE OF CONTENTS

### **DIVISION 1 – GENERAL REQUIREMENTS**

01010	SUMMARY OF WORK
01011	SPECIAL INSPECTIONS
01025	BASIS OF PAYMENT
01070	ABBREVIATIONS
01090	REFERENCE STANDARDS
01200	PROJECT MEETINGS
01300	SUBMITTALS
01400	TESTING AND INSPECTION
01500	CONSTRUCTION CONSIDERATIONS
01510	TEMPORARY UTILITIES
01520	MAINTENANCE OF FACILITIES AND SEQUENCE OF CONSTRUCTION
01530	PROTECTION OF EXISTING FACILITIES
01550	SITE ACCESS AND STORAGE
01560	TEMPORARY ENVIRONMENTAL CONTROLS
01590	FIELD OFFICE, EQUIPMENT AND SERVICES
01600	EQUIPMENT AND MATERIALS
01650	EQUIPMENT TESTING AND STARTUP
01700	PROJECT CLOSEOUT

### **DIVISION 2 – SITEWORK**

02050	DEMOLITION
-------	------------

**DIVISION 3 – CONCRETE (NOT USED)**

**DIVISION 4 – MASONRY (NOT USED)**

**DIVISION 5 – METALS**

- 05010 METAL MATERIALS
- 05050 METAL FASTENING
- 05500 METAL FABRICATIONS
- 05520 HANDRAILS AND RAILINGS
- 05531 GRATINGS, FLOOR PLATES, AND ACCESS HATCHES

**DIVISION 6 – WOOD AND PLASTICS**

- 06620 SCUM BAFFLES AND WEIR PLATES (ALTERNATE BID ITEM)
- 06650 DENSITY CURRENT BAFFLES (ALTERNATE BID ITEM)

**DIVISION 7 – THERMAL AND MOISTURE PROTECTION**

- 07920 JOINT FILLERS, SEALANTS AND CAULKING

**DIVISION 8 – DOORS AND WINDOWS (NOT USED)**

**DIVISION 9 – FINISHES**

- 09900 PAINTING

**DIVISION 10 – SPECIALTIES (NOT USED)**

**DIVISION 11 – EQUIPMENT**

- 11000 EQUIPMENT GENERAL PROVISIONS
- 11232 FINAL CLARIFIER MECHANISM REPLACEMENT (ALTERNATE BID ITEM)

**DIVISION 12 – FURNISHINGS (NOT USED)**

**DIVISION 13 – SPECIAL CONSTRUCTION (NOT USED)**

**DIVISION 14 – CONVEYING SYSTEMS (NOT USED)**

**DIVISION 15 – MECHANICAL CONSTRUCTION**

15000	BASIC MECHANICAL REQUIREMENTS
15006	DUCTILE IRON PIPE
15009	PVC PRESSURE PIPE
15030	PIPING AND EQUIPMENT IDENTIFICATION SYSTEMS
15095	VALVES, GENERAL
15104	BALL VALVES
15109	PLUG VALVES
15114	MISCELLANEOUS VALVES AND APPURTENANCES
15995	PIPELINE TESTING

**DIVISION 16 – ELECTRICAL**

16000	BASIC ELECTRICAL REQUIREMENTS
16111	CONDUIT
16123	LOW VOLTAGE WIRE AND CABLE
16130	BOXES
16190	SUPPORTING DEVICES
16195	ELECTRICAL-IDENTIFICATION
16480	LOW VOLTAGE ELECTRIC MOTORS
16902	ELECTRIC CONTROLS AND RELAYS

**DIVISION 17 - INSTRUMENTATION**

17000	CONTROL AND INFORMATION SYSTEM SCOPE AND GENERAL REQUIREMENTS
17030	CONTROL AND INFORMATION SYSTEM SUBMITTALS
17040	CONTROL AND INFORMATION SYSTEM TRAINING REQUIREMENTS
17060	SIGNAL COORDINATION REQUIREMENTS
17070	CONTROL AND INFORMATION SYSTEM TESTING - GENERAL
17072	FIELD TESTING
17080	QUALITY ASSURANCE
17300	MISCELLANEOUS MODIFICATIONS
17560	TRANSIENT VOLTAGE SURGE SUPPRESSION DEVICES
17920	CONTROL SYSTEM INPUT/OUTPUT SCHEDULE
17950	FUNCTIONAL CONTROL DESCRIPTIONS



## **TECHNICAL SPECIFICATIONS**

**DIVISION 1 – GENERAL REQUIREMENTS**

## SECTION 01010 - SUMMARY OF WORK

### PART 1 -- GENERAL

#### 1.01 THE REQUIREMENT

- A. The work to be performed under this Contract shall consist of furnishing all tools, equipment, materials, supplies, and manufactured articles and for furnishing all transportation and services, including fuel, power, water, and essential communications, and for the performance of all labor, work, or other operations required for the fulfillment of the Contract in strict accordance with the Contract Documents. The work shall be complete, and all work, materials, and services not expressly shown or called for in the Contract documents which may be necessary for the complete and proper construction of the work in good faith shall be performed, furnished, and installed by the CONTRACTOR as though originally so specified or shown, at no increase in cost to the CITY.
- B. Prior to construction, the CONTRACTOR shall verify existing utilities identified on the Drawings and locate other potential utilities in their working area that may not be shown on the Drawings. The utility verifications consist of excavation to verify tie-in points and to locate potential conflicts that may affect the work as shown on the Drawings. The CONTRACTOR shall be responsible for the coordination of this work with the associated utility owners and permitting agencies having jurisdiction over the specific locations to be verified.

#### 1.02 SCOPE

- A. The work to be performed includes civil, sitework, mechanical, structural, electrical, instrumentation and all related work associated with the following:
  - Clarifier No. 3 Repair: This work includes repair to the failed 16-inch diameter 90-degree elbow joint and pipe segment on the return sludge line (ductile iron pipe) located below grade within the 48-inch diameter influent line at Clarifier No. 3. Due to the location of the repair, this work includes dismantling, relocating/protecting and re-installing existing clarifier mechanism equipment once repair work is completed and deemed acceptable by the CITY. Work includes miscellaneous welding, and all related electrical, instrumentation, and controls work for a complete and operable system. In addition, this work includes all construction sequencing requirements, all startup and training activities, and all other work required for a complete and operating facility. Any existing concrete damaged during the work shall be repaired according to the Contract documents.
  - Alternate Bid Item No. A-1 – Furnish and Install Clarifier No. 3 Equipment (Complete Mechanism Replacement, Carbon Steel): Per CITY directive, this work includes all labor, equipment, and materials to perform complete replacement of the Clarifier No. 3 drive and associated appurtenances. The material of the replacement mechanism components shall be carbon steel with required surface preparation and coating system in accordance with the Contract documents. Refer to specification Sections 11232 and 09900. Work

shall include surface preparation and coating of new equipment, miscellaneous welding, and all related electrical, instrumentation and controls work. Following dismantle and removal of the existing Clarifier No. 3 mechanism (under Base Bid item scope), the ENGINEER and CITY shall be notified to determine the extent (if any) of repairs required to the existing equipment. Determination shall be made by the CITY regarding replacement of the clarifier mechanism. If approved, the CITY shall issue a written Field Order directing the Contractor to proceed with the work detailed in this Alternate Bid Item. The resulting time impact on the Contract schedule shall be submitted to the CITY prior. No additional payment will be made for the Work if the CITY chooses not to issue a Field Order to perform any of the identified equipment replacement work.

- Alternate Bid Item No. A-2 – Furnish and Install Clarifier No. 3 Equipment (Complete Mechanism Replacement, 316 Stainless Steel ): Per CITY directive, this work includes all labor, equipment, and materials to perform complete replacement of the Clarifier No. 3 drive and associated appurtenances. The material of replacement mechanism components shall be 316 stainless steel in accordance with the Contract documents. Refer to specification Sections 11232 and 09900. Work shall include miscellaneous welding, and all related electrical, instrumentation and controls work. Following dismantle and removal of the existing Clarifier No. 3 mechanism (under Base Bid item scope), the ENGINEER and CITY shall be notified to determine the extent (if any) of repairs required to the existing equipment. Determination shall be made by the CITY regarding replacement of the clarifier mechanism. If approved, the CITY shall issue a written Field Order directing the Contractor to proceed with the work detailed in this Alternate Bid Item. The resulting time impact on the Contract schedule shall be submitted to the CITY prior. No additional payment will be made for the Work if the CITY chooses not to issue a Field Order to perform any of the identified equipment replacement work.
- Alternate Bid Item No. A-3 – Furnish and Install Clarifier No. 3 Weirs and Scum Baffles: Per CITY directive, this work consists of furnishing and replacing the fiberglass v-notched weirs and scum baffles at Clarifier No. 3. Following dismantle and removal of the existing Clarifier No. 3 equipment (under Base Bid item scope), the ENGINEER and CITY shall be notified to determine the extent (if any) of repairs required to the existing weirs and baffles. Determination shall be made by the CITY regarding replacement. If approved, the CITY shall issue a written Field Order directing the Contractor to proceed with the work detailed in this Alternate Bid Item. The resulting time impact on the Contract schedule shall be submitted to the CITY prior. No additional payment will be made for the Work if the CITY chooses not to issue a Field Order to perform any of the identified equipment replacement work.
- Alternate Bid Item No. A-4 – Furnish and Install Clarifier No. 3 Density Current Baffles: Per CITY directive, this work consists of furnishing and replacing the density current baffles at Clarifier No. 3. Following dismantle and removal of the existing Clarifier No. 3 equipment (under Base Bid item scope), the ENGINEER and CITY shall be notified to determine the extent (if any) of repairs required to the existing density current baffles. Determination shall be made by the CITY regarding replacement. If approved, the CITY shall issue a written Field Order directing the Contractor to proceed with the work detailed in this Alternate Bid

Item. The resulting time impact on the Contract schedule shall be submitted to the CITY prior. No additional payment will be made for the Work if the CITY chooses not to issue a Field Order to perform any of the identified equipment replacement work.

- B. It is the intent of the CITY to obtain a complete and working installation under this contract and any items of labor, materials or equipment, which may reasonably be assumed as necessary to accomplish this end, should be supplied whether or not specifically shown on the plans or described herein. Maintenance of existing operations is mandated throughout the construction period.

#### 1.03 WORK BY OTHERS

- A. The CONTRACTOR shall cooperate fully with all utility forces of the CITY, or other public or private agencies engaged in the relocation, altering, or otherwise rearranging of any facilities which interfere with the progress of the work, and shall schedule the work so as to minimize interference with said relocation, altering, or rearranging of facilities.
- B. The CONTRACTOR's attention is directed to the fact that work will be conducted at the site by other contractors during the performance of the work under this Contract. The CONTRACTOR shall conduct its operations so as to cause a minimum of interference with the Work of such other contractors, and shall cooperate fully with such contractors to provide continued safe access to their respective portions of the site, as required to perform their respective contracts.
- C. When two or more contracts are being executed at one time on the same or adjacent land in such manner that Work on one contract may interfere with that on another, the CITY shall determine the sequence and order of the Work. When the territory of one contract is the necessary or convenient means of access for the execution of another contractor, such privilege of access or any other reasonable privilege may be granted by the CITY to CONTRACTOR.

#### 1.04 LOCATION OF THE PROJECT

- A. The project is located at the City of Hollywood's Southern Regional Wastewater Treatment Plant at 1621 North 14<sup>th</sup> Avenue, Hollywood, Florida.

#### 1.05 CONTRACT DRAWINGS

- A. The work to be performed is shown on the set of Contract Drawings entitled "City of Hollywood Southern Regional Wastewater Treatment Plant, Clarifier No. 3 Repair".

#### 1.06 CONTRACTOR FURNISHED MATERIAL AND EQUIPMENT

- A. All equipment, materials, or devices incorporated in this project shall be new and unused, unless indicated otherwise in the Contract Documents and shall be the products of reliable manufacturers who, unless otherwise specified, have been regularly engaged in the manufacture of such material and equipment for at least five (5) years. Procedures and additional requirements regarding manufacturer's experience and substitutions are included in Section 01300 - Submittals.

## 1.07 DRAWINGS OF EXISTING FACILITIES

- A. Drawings of the existing facilities may be inspected at the City Engineering Support Services Office. These drawings are for information only and are not a part of the Contract Documents. In making these drawings available for inspection, the CITY makes no guarantee, either expressed or implied, as to their accuracy or completeness.

## 1.08 ITEMS SPECIFIED ON DRAWINGS

- A. Certain items of material and/or equipment, and their installation may be specified on the Drawings and not mentioned in the Specifications. Such items are to be considered as both shown on the Drawings and noted in the Specifications and be provided by the CONTRACTOR in accordance with the Specification on the Drawings.

## 1.09 FIELD LAYOUT OF WORK

- A. All work under this Contract shall be constructed in accordance with the lines and grades shown on the Contract Drawings or as directed by the ENGINEER. Elevations of existing ground, structures and appurtenances are believed to be reasonably correct but are not guaranteed to be absolute and therefore are presented only as an approximation. Any error or apparent discrepancy in the data shown or omissions of data required for accurately accomplishing the stake-out survey shall be referred immediately to the ENGINEER for interpretation or correction.
- B. All survey work for construction control purposes shall be made by the CONTRACTOR at his expense.
- C. The CONTRACTOR shall establish all base lines for the location of the principal component parts of the work together with benchmarks and batter boards adjacent to the work. Based upon the information provided by the Contract Drawings, the CONTRACTOR shall develop and make all detail surveys necessary for construction. The CITY will furnish information and location of existing benchmarks.
- D. The CONTRACTOR shall have the responsibility to carefully preserve the benchmarks, reference points and stakes. In case of destruction thereof by the CONTRACTOR or resulting from his negligence, he shall be held liable for any expense and damage resulting therefrom and shall be responsible for any mistakes that may be caused by the unnecessary loss or disturbance of such bench marks, reference points and stakes.
- E. Existing or new control points, property markers, and monuments that will be established or are destroyed during the normal causes of construction shall be re-established by the CONTRACTOR; and all reference ties recorded therefore shall be furnished to the ENGINEER. All computations necessary to establish the exact position of the work shall be made and preserved by the CONTRACTOR.
- F. The ENGINEER may check all or any portion of the work, and the CONTRACTOR shall afford all necessary assistance to the ENGINEER in carrying out such checks. Any necessary corrections to the work shall be performed immediately by the CONTRACTOR and he shall accept all responsibility for the accuracy and completeness of his work.

PART 2 -- PRODUCTS (Not Used)

PART 3 -- EXECUTION (Not Used)

- END OF SECTION -

## SECTION 01011 - SPECIAL INSPECTIONS

### PART 1 – GENERAL

#### 1.01 THE REQUIREMENT

- A. The CONTRACTOR, in accordance with Section 109.11 of the Broward County Administrative Code and the Florida Building Code, shall retain a Special Inspector to perform the applicable inspections outlined in Sections 109.11, 1822, 2122.4, 2223.11.1, 1927.12.1, and 1927.12.2 of the Florida Building Code.
- B. The Special Inspector shall be a Professional Engineer licensed in the State of Florida.
- C. At a minimum, the following inspections shall be provided where applicable:
  - 1. Precast concrete units – Section 1927.12.1 and 109.11.2.1;
  - 2. Precast concrete units – Section 1927.12.2 and 109.11.2.1;
  - 3. Reinforced unit masonry – Section 2122.4 and 109.11.2.2 (per ACI 530.1-05-Level B Quality Assurance unless noted otherwise on the Drawings);
  - 4. Connections – Section 2218.2 and 109.11.2.3
  - 5. Metal Building Systems – Section 2223.11.1 and 109.11.2.4
- D. Additional inspections may be required at the discretion of the Building Official per Section 109.11.1.1 of the Broward County Administrative Code and the Florida Building Code.
- E. It is recognized that the scope of services associated with providing the special inspector services cannot be quantified until the CONTRACTOR applies for a Building Permit with the City of Hollywood Building Department and the Building Department defines the scope of special inspections.
- F. The allowance amount is an estimate and is a cost pass through item and no mark-ups will be added to this item. The CONTRACTOR shall produce documentation upon request verifying actual cost. Any portion of the allowance that remains after all authorized payments have been made will be withheld from contract payments and will remain with the CITY.

#### 1.02 SPECIAL BUILDING INSPECTOR FORM

- A. CONTRACTOR shall prepare and submit the Form for “Special Building Inspection” as required by the Building Department with jurisdiction. The form shall be executed by the Professional Engineer licensed in the state of Florida.
- B. Provide a copy of the form that is submitted to the Building Department to the ENGINEER and the CITY for informational purposes.



### 1.03 INSPECTION REPORTS

- A. Prepare a log of all progress reports and inspections related to the Special Inspections required by the Building Official. The log shall be maintained at the job site.
- B. On a weekly basis submit signed and sealed progress reports and inspection reports to the Building Official as per Sections 109.11.6 of the Florida Building Code.
- C. Provide copies of the reports that are submitted to the Building Department to the ENGINEER and the CITY for informational purposes.

### 1.04 CERTIFICATION

- A. The Special Inspector shall submit a Certificate of Compliance prior to scheduling the final building inspection in accordance with Section 109.11.7 of the Building Code.
- B. The Certificate of Compliance shall state that the work performed by the CONTRACTOR was done in accordance with the applicable portion of the permitted construction documents as delineated in the special building inspection plan.
- C. Furnish a copy of the Certificate of Compliance to the CITY and the ENGINEER.

PART 2 -- PRODUCTS (Not Used)

PART 3 -- EXECUTION (Not Used)

- END OF SECTION -

## SECTION 01025 - BASIS OF PAYMENT

### PART 1 -- GENERAL

#### 1.01 GENERAL

- A. Payments to the CONTRACTOR shall be made on the basis of the Proposal bid items as full and complete payment for furnishing all materials, labor, tools and equipment, and for performing all operations necessary to complete the work included in the Contract Documents. Such compensation shall also include payments for any loss or damages arising directly or indirectly from the work, or from any discrepancies between the actual quantities of work and those shown in the Contract Documents, or from any unforeseen difficulties which may be encountered during the prosecution of the work until the final acceptance by the CITY.
- B. The prices stated in the proposal include all costs and expenses for taxes, labor, equipment, materials, commissions, transportation charges and expenses, patent fees and royalties, labor for handling materials during inspection, together with any and all other costs and expenses for performing and completing the work as shown on the plans and specified herein. The Basis of Payment for an item at the price shown in the Proposal shall be in accordance with its description of the item in this Section and as related to the work specified and as shown on the Drawings. Unit prices where used will be applied to the actual quantities furnished and installed in conformance with the Contract Documents.
- C. The CONTRACTOR's attention is called to the fact that the quotations for the various items of work are intended to establish a total price for completing the work in its entirety. Should the CONTRACTOR feel that the cost of any item of work has not been established by the Proposal or Basis of Payment, he shall include the cost for that work in the last Bid Item so that his proposal for the project does reflect his total price for completing the work in its entirety.

#### 1.02 MEASUREMENT

- A. The quantities for payment under this Contract shall be determined by actual measurement of the completed items, in place, ready for service and accepted by the CITY, in accordance with the Schedule of Payment Values as described in Section 01300, unless otherwise specified. A representative of the CONTRACTOR shall witness all field measurements.

## 1.03 PAYMENT ITEMS

### A. Base Bid Items

1. Item No. 1 – Mobilization: The lump sum price bid for this item shall be full compensation for all mobilization activities, including but not limited to bonds, insurance, scheduling, labor associated with permit acquisition, temporary facilities, audio-video documentation of the existing site, preparation and submittal of shop drawings, and all other activities necessary to prepare to complete the contract work. The payment item for mobilization shall not exceed 3% of the sum of Bid Item Nos. 2 through 3.
2. Item No. 2 – Clarifier No. 3 Repair: Payment for all labor, equipment, and materials for all work necessary and required for the repair of a failed 16-inch diameter 90-degree elbow joint and pipe segment on the return sludge line (ductile iron pipe) located below grade within the 48-inch diameter clarifier feed line at Clarifier No. 3, as required in the Contract Documents. Due to the location of the repair work, this item also includes dismantling and removal of the clarifier mechanism as necessary to perform said repair work, and protection and storage of existing equipment. In addition, this item includes all work necessary to furnish and install a 16-inch diameter plug valve on the return sludge line on the west side of Clarifier No. 3 as shown on the drawings. This item includes, but is not limited to, all general, civil, mechanical, structural, architectural, electrical, instrumentation and control work required to perform the repair, as specified in the Contract Documents. Bid Item No. 2 includes all work for Clarifier No. 3 not defined in other Bid Items.
3. Item No. 3 – Clarifier No. 3 Re-installation of Equipment and Restoration of Operation: Payment for all labor, equipment, and materials for all work necessary and required for the restoration of operation of Clarifier No. 3, following the repair work described in Bid Item No. 2. This item includes the reassembly/installation of existing equipment and all work necessary to return clarifier to service. This item includes, but is not limited to, all general, civil, mechanical, structural, architectural, electrical, instrumentation and control, equipment testing, startup services and construction sequencing required for a complete and operable system. Any existing concrete damaged during the work shall be repaired according to the Contract documents.
4. Item No. 4 – Permit Fee Allowance: Payment for permit fees will be based upon the actual permit fees required by the Contractor from the various agencies having jurisdiction for construction of the project, in accordance with the Contract Documents. The allowance amount shown on the bid schedule is an estimate of permit fees required for the project and is a cost pass-through item. No mark-ups will be allowed to this item. The Contractor shall produce documentation upon request verifying actual cost. Only permit fees substantiated by the Contractor and approved by the Engineer will be paid as part of this bid item. Any portion of this allowance that remains after all authorized payments have been made will be withheld from contract payments and will remain with the Owner. Fees specifically excluded from this allowance include re-inspection fees and expired permit fees.
5. Item No. 5 – Undefined Conditions Allowance: Included in this allowance is work associated with undefined conditions or conflicts developing from undefined conditions.

All work authorized for payment will be authorized in writing by the CITY. Amount to be paid per undefined conditions or conflicts shall be negotiated or agreed to by both parties.

6. Item No. 6 – Consideration for Indemnification: In recognition of CONTRACTOR's indemnification obligations, the CITY will pay to the CONTRACTOR the specific consideration of ten dollars (\$10.00). Payment of said specific consideration shall be made at the time of the payment of the first progress estimate and the CONTRACTOR shall acknowledge payment of this consideration by letter to the CITY after receipt of the progress payment.
7. Item No. 7 – Demobilization: Payment for completing all other work including but not limited to demobilization, site cleanup and restoration - all as per the Technical Specifications and Contract Drawings. The payment items for demobilization shall not exceed 2% of the sum of Bid Item Nos. 2 through 3.

B. Alternate Bid Items

The following items are at the CITY's option and shall not be included in the Total Base Bid.

- A-1. Item No. A-1 – Furnish and Install Clarifier No. 3 Equipment (Complete Mechanism Replacement, Carbon Steel): The following item is for complete replacement of the mechanism at Clarifier No. 3, in the event it is deemed necessary. The material of the replacement mechanism shall be carbon steel components with required surface preparation and coating system per the Contract documents. Item shall include payment for all labor, equipment, and materials for all work necessary and required for the replacement of equipment as detailed in the Contract Documents. This item includes, but is not limited to, all general, civil, mechanical, structural, architectural, electrical, instrumentation and control, equipment testing, startup services and construction sequencing required for a complete and operable system. Work includes but is not limited to furnishing, delivering, installing and testing Clarifier No. 3 drive and associated appurtenances. This item includes the removal and replacement of up to 300 linear feet of Schedule 80 PVC piping, 3 inches in diameter or less not already shown to be removed and replaced on the Drawings. Electrical and instrumentation work includes replacement of conduit and wiring for the clarifier and all work necessary to provide local and remote controls and displays required in the Contract Documents. The payment item for Alternate Bid Item A-1 shall be a net increase in the Base Bid upon approval by the ENGINEER and CITY.
- A-2 Item No. A-2 – Furnish and Install Clarifier No. 3 Equipment (Complete Mechanism Replacement, 316 Stainless Steel): The following item is for complete replacement of the mechanism at Clarifier No. 3, in the event it is deemed necessary. The material of the replacement mechanism shall include 316 stainless steel components per the Contract documents. Item shall include payment for all labor, equipment, and materials for all work necessary and required for the replacement of equipment as detailed in the Contract Documents. This item includes, but is not limited to, all general, civil, mechanical, structural, architectural, electrical, instrumentation and control, equipment testing, startup services and construction sequencing required for a complete and operable system. Work includes but is not limited to furnishing, delivering, installing and testing Clarifier No. 3 drive and associated appurtenances. This item includes the

removal and replacement of up to 300 linear feet of Schedule 80 PVC piping, 3 inches in diameter or less not already shown to be removed and replaced on the Drawings. Electrical and instrumentation work includes replacement of conduit and wiring for the clarifier and all work necessary to provide local and remote controls and displays required in the Contract Documents. The payment item for Alternate Bid Item A-2 shall be a net increase in the Base Bid upon approval by the ENGINEER and CITY.

- A-3 Item No. A-3 – Furnish and Install Clarifier No. 3 Weirs and Scum Baffles: The following item is for replacement of the fiberglass v-notched weirs and scum baffles at Clarifier No. 3, in the event it is deemed necessary. Item shall include payment for all labor, equipment, and materials for all work necessary and required for the replacement of equipment, as detailed in the Contract Documents, for a complete and operable system. The payment item for Alternate Bid Item A-3 shall be a net increase in the Base Bid upon approval by the ENGINEER and CITY.
- A-4 Item No. A-4 – Furnish and Install Clarifier No. 3 Density Current Baffles: The following item is for replacement of the density current baffles at Clarifier No. 3, in the event it is deemed necessary. Item shall include payment for all labor, equipment, and materials for all work necessary and required for the replacement of equipment, as detailed in the Contract Documents, for a complete and operable system. The payment item for Alternate Bid Item A-4 shall be a net increase in the Base Bid upon approval by the ENGINEER and CITY.

PART 2 -- PRODUCTS (Not Used)

PART 3 -- EXECUTION (Not Used)

- END OF SECTION -

## SECTION 01070 - ABBREVIATIONS

### PART 1 -- GENERAL

#### 1.01 THE REQUIREMENT

- A. Wherever in these specifications references are made to the standards, specifications, or other published data of the various national, regional, or local organizations, such organizations may be referred to by their acronym or abbreviation only. As a guide to the user of these specifications, the following acronyms or abbreviations which may appear in these specifications shall have the meanings indicated herein.

#### 1.02 ABBREVIATIONS AND ACRONYMS

AAMA	Architectural Aluminum Manufacturer's Association
AASHTO	American Association of the State Highway and Transportation Officials
ACI	American Concrete Institute
ACIFS	American Cast Iron Flange Standards
ACOE	Army Corps of Engineers
ACPA	American Concrete Pipe Association
AFBMA	Anti-Friction Bearing Manufacturer's Association, Inc.
AGMA	American Gear Manufacturer's Association
AHGDA	American Hot Dip Galvanizers Association
AI	The Asphalt Institute
AIA	American Institute of Architects
AISC	American Institute of Steel Construction
AISI	American Iron and Steel Institute
AITC	American Institute of Timber Construction
AMCA	Air Moving and Conditioning Association
ANSI	American National Standards Institute, Inc.
APA	American Plywood Association
API	American Petroleum Institute
APHA	American Public Health Association
APWA	American Public Works Association
ASA	Acoustical Society of America
ASAE	American Society of Agriculture Engineers
ASCE	American Society of Civil Engineers
ASHRAE	American Society of Heating, Refrigerating, and Air-Conditioning Engineers
ASLE	American Society of Lubricating Engineers

ASME American Society of Mechanical Engineers

ASMM Architectural Sheet Metal Manual

ASSE American Society of Sanitary Engineers

ASTM American Society for Testing and Materials

AWPA American Wood Preservers Association

AWPI American Wood Preservers Institute

AWS American Welding Society

AWWA American Water Works Association

BCEPGMD Broward County Environmental Protection and Growth Management  
Department (formerly BCEPD)

BCHDB Broward County Health Department

CEMA Conveyor Equipment Manufacturer's Association

CMA Concrete Masonry Association

CRSI Concrete Reinforcing Steel Institute

DIPRA Ductile Iron Pipe Research Association

EIA Electronic Industries Association

ETL Electrical Test Laboratories

FBC Florida Building Code

FDEP Florida Department of Environmental Protection

FDOT Florida Department of Transportation

FS Federal Specifications

IEEE Institute of Electrical and Electronics Engineers

IES Illuminating Engineering Society

IPCEA Insulated Power Cable Engineers Association

ISA Instrument Systems and Automation

ISO International Organization for Standardization

MBMA Metal Building Manufacturers Association

MMA Monorail Manufacturers Association

MTI Marine Testing Institute

NAAM National Association of Architectural Metal Manufacturers

NACE National Association of Corrosion Engineers

NBS National Bureau of Standards

NEC National Electrical Code

NEMA National Electrical Manufacturer's Association

NFPA National Fire Protection Association

NIOSH	National Institute of Occupational Safety and Health
NIST	National Institute of Standards and Testing
NRC	National Roofing Contractors Association
NSF	National Science Foundation
OSHA	Occupational Safety and Health Administration
PCA	Portland Cement Association
PCM	Program Construction Manager
PMT	Program Management Team
SFWMD	South Florida Water Management District
SMACNA	Sheet Metal and Air Conditioning Contractors National Association
SSPC	Steel Structures Painting Council
SSPWC	Standard Specifications for Public Works Construction
SFWMD	South Florida Water Management District
UL	Underwriters Laboratories, Inc.

PART 2 -- PRODUCTS

(NOT USED)

PART 3 -- EXECUTION

(NOT USED)

- END OF SECTION -



## SECTION 01090 - REFERENCE STANDARDS

### PART 1 -- GENERAL

#### 1.01 WORK INCLUDED

- A. Titles of Sections and Paragraphs: Captions accompanying specification sections and paragraphs are for convenience of reference only, and do not form a part of the Specifications.
- B. Applicable Publications: Whenever in these Specifications references are made to published specifications, codes, standards, or other requirements, it shall be understood that wherever no date is specified, only the latest specifications, standards, or requirements of the respective issuing agencies which have been published as of the date of the opening of bids, shall apply; except to the extent that said standards or requirements may be in conflict with applicable laws, ordinances, or governing codes. No requirements set forth herein or shown on the Drawings shall be waived because of any provision of, or omission from, said standards or requirements.
- C. Specialists, Assignments: In certain instances, Specification text requires (or implies) that specific work is to be assigned to specialists or expert entities, who must be engaged for the performance of that work. Such assignments shall be recognized as special requirements over which the CONTRACTOR has no choice or option. These requirements shall not be interpreted so as to conflict with the enforcement of building codes and similar regulations governing the Work; also they are not intended to interfere with local union jurisdiction settlements and similar conventions. Such assignments are intended to establish which party or entity involved in a specific unit of work is recognized as "expert" for the indicated construction processes or operations. Nevertheless, the final responsibility for fulfillment of the entire set of Contract requirements remains with the CONTRACTOR.

#### 1.02 REFERENCE SPECIFICATIONS, CODES, AND STANDARDS

- A. Without limiting the generality of other requirements of the specifications, all work specified herein shall conform to or exceed the requirements of all applicable codes.
- B. References herein to "Building Code" shall mean the Florida Building Code. The latest edition of the code as approved and used by the local agency as of the date of the Building Department Permit Approval, as adopted by the agency having jurisdiction, shall apply to the Work herein, including all addenda, modifications, amendments, or other lawful changes thereto.
- C. In case of conflict between codes, reference standards, Drawings and the other Contract Documents, the most stringent requirements shall govern. All conflicts shall be brought to the attention of the ENGINEER for clarification and directions prior to ordering or providing any materials or labor. The CONTRACTOR shall bid the most stringent requirements.
- D. Applicable Standard Specifications: The CONTRACTOR shall construct the Work specified herein in accordance with the requirements of the Contract Documents and the referenced portions of those referenced codes, standards, and Specifications listed herein.

- E. References herein to "OSHA Regulations for Construction" shall mean Title 29, Part 1926, Construction Safety and Health Regulations, Code of Federal Regulations (OSHA), including all changes and amendments thereto.
- F. References herein to "OSHA Standards" shall mean Title 29, Part 1910, Occupational Safety and Health Standards, Code of Federal Regulations (OSHA), including all changes and amendments thereto.

PART 2 -- PRODUCTS

(NOT USED)

PART 3 -- EXECUTION

(NOT USED)

- END OF SECTION -

## SECTION 01200 - PROJECT MEETINGS

### PART 1 -- GENERAL

#### 1.01 PRECONSTRUCTION

- A. A preconstruction meeting will be held to acquaint representatives of the CITY and various agencies with those in responsible charge of the CONTRACTOR's activities for the project. The meeting will cover such subjects as the following: insurance certificates; permits and licenses; affirmative action employment; construction schedules; cost breakdown and application for payments; material deliveries, storage and payments; shop drawings and submittals; job-site inspection by the ENGINEER; safety and emergency action procedures; operations of the existing treatment facilities; field offices, security and other housekeeping procedures; list of subcontractors; liquidated damages; communications; coordinating; and other appropriate matters.

#### 1.02 PROGRESS

- A. A progress meeting shall be held on a bi-weekly basis for the purpose of coordinating and expediting the work. The CONTRACTOR, as a part of his obligations under the Contract, shall attend in person or by an authorized representative to attend and to act on his behalf. The ENGINEER will conduct such meetings and as necessary, with the CONTRACTOR's input, issue an agenda.
- B. In addition, the ENGINEER or CONTRACTOR may call for special job site meetings for the purpose of resolving unforeseen problems or conflicts which may impede the construction schedule. The ENGINEER will prepare a brief summary report of the decisions or understandings concerning each of the items discussed at the meeting.
- C. At bi-weekly progress meetings, the CONTRACTOR shall submit to the ENGINEER for review a current three (3) week progress schedule. This schedule submission shall include a two week look ahead schedule and reflect status of the work performed during the preceding week.

### PART 2 -- PRODUCTS (Not Used)

### PART 3 -- EXECUTION (Not Used)

- END OF SECTION -

## SECTION 01300 - SUBMITTALS

### PART 1 -- GENERAL

#### 1.01 THE REQUIREMENT

- A. This section specifies the means of all submittals. All submittals, whether their final destination is to the CITY, ENGINEER, or other representatives of the CITY, shall be directed from the CONTRACTOR through the ENGINEER. A summary of the key types of submittals and the number of copies required is as follows:

<u>Copies to ENGINEER</u>	<u>Type of Submittal</u>
6 <sup>1</sup>	Construction schedule
6	Schedule of payment items
1	Audio visual preconstruction record
6	Progress estimates
6	Shop drawings
4	Certificates of compliance
2	Warranties
2 <sup>2</sup>	Product samples
5 <sup>2</sup>	O&M Manuals
1 <sup>3</sup>	Record drawings

<sup>1</sup>One USB flash drive containing the electronic source file shall be included

<sup>2</sup>Unless otherwise required in the specific Section where requested.

<sup>3</sup>One marked-up set of Drawings (Original Markup).

#### 1.02 SUBMITTAL PROCEDURES

- A. Transmit each submittal with a form acceptable to the ENGINEER, clearly identifying the project CONTRACTOR, the enclosed material and other pertinent information specified in other parts of this section. Identify variations from Contract Documents and Product or system limitations which may be detrimental to successful performance of the completed Work. Acceptance of submittals in electronic format via email attachment or USB flash drive shall be at the discretion of the CITY and ENGINEER. USB flash drives must be accompanied by the CONTRACTOR's transmittal stating the contents of the drive. Under no circumstances will hyperlinks to internet site(s) for submittal retrieval by the CITY or ENGINEER be accepted.
- B. Revise and resubmit submittals as required. Identify all changes made since previous submittals. Resubmittals shall be noted as such.
- C. Distribute copies of reviewed submittals to concerned parties. Instruct parties to promptly report any inability to comply with provisions.

### 1.03 CONSTRUCTION PROGRESS SCHEDULE

- A. The CONTRACTOR shall have the capability of preparing and utilizing the specified construction progress scheduling techniques. A statement of capability shall be submitted in writing to the ENGINEER with the return of the executed Agreement to the CITY and will verify that either the CONTRACTOR's organization has in-house capability qualified to use the technique or that the CONTRACTOR employs a consultant who is so qualified. Capability shall be verified by description of the construction projects to which the CONTRACTOR or its consultant has successfully applied the scheduling technique and which were controlled throughout the duration of the project by means of systematic use and updating of the construction progress schedule, the network analysis and associated reports. The submittal shall include the name of the individual on the CONTRACTOR's staff who will be responsible for the construction progress schedule, and associated reports and for providing the required updating information of same. The CONTRACTOR shall submit its proposed progress (baseline) schedule to the ENGINEER for review and comment within thirty days of the Notice to Award. The ENGINEER shall have the authority to determine acceptability/correctness of the schedule logic and activity interrelationships. The use of extraneous, nonworking activities and activities which add restraints to the construction schedule shall not be accepted. Baseline schedules that do not meet their contract completion dates shall not be accepted.
- B. The Contractor's progress schedule (baseline and monthly updates) shall be computer generated and resource loaded. Each construction progress schedule, and associated report shall include the following tabulations: a list of activities in numerical order, a list of activity precedence, schedules sequenced by Early Start Date, Total Float, and Late Start Date. Each schedule, and report shall include the following minimum items.
1. Activity Numbers
  2. Estimated Duration
  3. Activity Description
  4. Early Start Date (Calendar Dated)
  5. Early Finish Date (Calendar Dated)
  6. Latest Allowable Start Date (Calendar Dated)
  7. Latest Allowable Finish Date (Calendar Dated)
  8. Status (whether critical)
  9. Estimated Cost of the Activity
  10. Total Float and Free Float
- C. In addition, each construction progress schedule, network analysis and report shall be prefaced with the following summary data:

1. Contract Name and Number
  2. CONTRACTOR'S Name
  3. Contract Duration and Float
  4. Contract Schedule
  5. The Effective or Starting Date of the Schedule (the date indicated in the Notice-to-Proceed)
- D. The work day to calendar date correlation shall be based on an 8-hour day and 40-hour week with adequate allowance for holidays and all other special requirements of the Work. A total of five (5) days for adverse weather shall also be allowed for in the progress schedule such that the CONTRACTOR can secure the jobsite as specified in Section 01560.
- E. If the CONTRACTOR desires to make changes in its method of operating which affect the construction progress schedule and related items, the CONTRACTOR shall notify the ENGINEER in writing stating what changes are proposed and the reason for the change. If the ENGINEER accepts these changes, in writing, the CONTRACTOR shall revise and submit, without additional cost to the CITY, all of the affected portions of the construction progress schedule, and associated reports. The construction progress schedule and related items shall be adjusted by the CONTRACTOR only after prior acceptance, in writing by the ENGINEER. Adjustments may consist of changing portions of the activity sequence, activity durations, division of activities, or other adjustments as may be required. The addition of extraneous, nonworking activities and activities which add restraints to the construction progress schedule shall not be accepted.
- F. Except where earlier completions are specified, schedule dates which show completion of all Work prior to the contract completion date shall, in no event, be the basis for claim for delay against the CITY by the CONTRACTOR.
- G. Construction progress schedules and related items which contain activities showing negative float or which extend beyond the contract completion date will not be accepted by the ENGINEER.
- H. Whenever it becomes apparent from the current construction progress schedule and associated reports that delays to the critical path have resulted and the contract completion date will not be met, or when so directed by the ENGINEER, the CONTRACTOR shall take some or all of the following actions at no additional cost to the CITY. They shall submit to the ENGINEER for approval, a written statement of the steps they intend to take to remove or arrest the delay to the critical path in the current construction progress schedule, including a computer generated schedule revision to reflect proposed actions.
1. Increase construction manpower in such quantities and crafts as will substantially eliminate the backlog of work.

2. Increase the number of working hours per shift, shifts per day, working days per week, the amount of construction equipment, or any combination of the foregoing, sufficiently to substantially eliminate the backlog of work.
  3. Reschedule activities to achieve maximum practical concurrency of accomplishment of activities, and comply with the revised schedule.
- I. If when so requested by the ENGINEER, the CONTRACTOR should fail to submit a written statement of the steps they intend to take or should fail to take such steps as reviewed and accepted in writing by the ENGINEER, the ENGINEER may direct the CONTRACTOR to increase the level of effort in manpower (trades), equipment and work schedule (overtime, weekend and holiday work, etc.) to be employed by the CONTRACTOR in order to remove or arrest the delay to the critical path in the current construction progress schedule, and the CONTRACTOR shall promptly provide such level of effort at no additional cost to the CITY.
  - J. If the completion of any activity, whether or not critical, falls more than 100 percent behind its previously scheduled and accepted duration, the CONTRACTOR shall submit for approval a schedule adjustment showing each such activity divided into two activities reflecting completed versus uncompleted work.
  - K. Shop drawings which are not approved on the first submittal or within the time scheduled, and equipment which does not pass the specified tests and certifications shall be immediately rescheduled. The CONTRACTOR shall allow a 21 day review period for all shop drawings and other submittals requiring approval by the ENGINEER.
  - L. The contract time will be adjusted only in accordance with the General Requirements and other portions of the Contract Documents as may be applicable. If the ENGINEER finds that the CONTRACTOR is entitled to any extension of the contract completion date, the ENGINEER's determination as to the total number of days extension shall be based upon the current construction progress schedule and on all data relevant to the extension. Such data shall be included in the next updating of the schedule and related items. Actual delays in activities which, according to the construction progress schedule, do not affect any contract completion date will not be the basis for a change therein.
  - M. From time to time it may be necessary for the contract schedule of completion time to be adjusted by the CITY in accordance with the General Requirements and other portions of the Contract Documents as may be applicable. Under such conditions, the ENGINEER will direct the CONTRACTOR to reschedule the Work or contract completion time to reflect the changed conditions, and the CONTRACTOR shall revise the construction progress schedule and related items accordingly, at no additional cost to the CITY.
  - N. Available float time may be used by the CITY through the CITY'S ENGINEER.
  - O. The CITY controls the float time and, therefore, without obligation to extend either the overall completion date or any intermediate completion dates, the CITY may initiate changes that absorb float time only. CITY initiated changes that affect the critical path on the network diagram shall be the sole grounds for extending the completion dates. CONTRACTOR initiated changes that encroach on the float time may be accomplished

only with the CITY'S concurrence. Such changes, however, shall give way to CITY initiated changes competing for the same float time.

- P. To the extent that the construction project schedule, or associated report or any revision thereof shows anything not jointly agreed upon or fails to show anything jointly agreed upon, it shall not be deemed to have been accepted by the ENGINEER. Failure to include on a schedule any element of Work required for the performance of this Contract shall not excuse the CONTRACTOR from completing all Work required within any applicable completion date, not withstanding the review of the schedule by the ENGINEER.
- Q. Review and acceptance of the construction progress schedule, and related reports, by the ENGINEER is advisory only and shall not relieve the CONTRACTOR of the responsibility for accomplishing the Work within the contract completion date. Omissions and errors in the construction progress schedule, and related reports shall not excuse performance less than that required by the Contract and in no way make the ENGINEER an insurer of the CONTRACTOR'S success or liable for time or cost overruns flowing from any shortcomings in the construction progress schedule, and related reports.
- R. The CONTRACTOR shall present and discuss the proposed schedule at the preconstruction conference.
- S. The construction progress schedule shall be based upon the precedence diagramming method of scheduling and shall be prepared in the form of a horizontal bar chart showing in detail the proposed sequence of the Work and identifying all construction activities included but not limited to yard piping, all structures and treatment units and all related Work specified herein to be performed under the Contract. The schedule shall be time scaled, identifying the first day of each week, with the estimated date of starting and completion of each stage of the Work in order to complete the project within the contract time. The project critical path shall be clearly identified in color or by other means acceptable to the ENGINEER.
- T. The progress schedule shall be plotted on 22-inch by 34-inch and 11-inch by 17-inch paper and shall be revised and updated monthly, depicting progress through the last day of the current month and scheduled progress through completion. Six (one 22-inch by 34-inch and five 11-inch by 17-inch), schedules, required schedule "sorts" (tabulations) and an electronic copy of the baseline schedule shall be submitted for review and acceptance. Six (one 22-inch by 34-inch and four 11-inch x 17-inch) up-to-date copies of the schedule and six copies of tabulations and an electronic copy shall be submitted along with the application for monthly progress payments for the same period.
- U. The construction progress schedule shall be developed and maintained using Primavera Sure Trak as manufactured by Primavera Systems, Inc., or equal.

#### 1.04 SCHEDULE OF PAYMENT VALUES

- A. The CONTRACTOR shall submit a Schedule of Payment Values, in accordance with Section 01025, for all items in the proposal that are to be paid for on a lump sum basis. The schedule shall contain the labor and material values of the component parts of



Work for the purpose of making progress payments during the construction period. The Schedule of Payment Values shall directly correlate on an item by item basis (unless otherwise accepted by the ENGINEER) to each individual activity detailed in the construction progress schedule.

- B. The schedule shall be given in sufficient detail for the proper identification of Work accomplished. Each item shall include its proportional share of all costs including the CONTRACTOR's overhead, contingencies and profit. The sum of all scheduled items shall equal the total value of the Contract.
- C. If the CONTRACTOR anticipates the need for payment for materials stored on the project site, it shall also submit a separate list covering the cost of materials, delivered and unloaded with taxes paid. This list shall also include the installed value of the item with coded reference to the Work items in the Schedule of Payment Items.
- D. The CONTRACTOR shall expand or modify the above schedule and materials listing as required by the ENGINEER'S initial or subsequent reviews.
- E. The CONTRACTOR shall update the Schedule of Payment Values monthly for reviewing by the ENGINEER. The payment applications shall be reviewed by the ENGINEER in accordance with the updated Schedule of Payment Values.

#### 1.05 SHOP DRAWINGS, PROJECT DATA AND SAMPLES

- A. General: A Shop Drawing Submittal Schedule shall be provided by the CONTRACTOR within thirty (30) days of the Notice to Proceed.
- B. The CONTRACTOR shall furnish for review ten (10) copies of shop drawings, project data, samples and other submittal items required by the Contract Documents. Three (3) copies shall be returned to the CONTRACTOR stamped "Furnish as Submitted" or "Furnish as Corrected". Where major corrections are indicated, two (2) copies will be returned stamped "Revise and Resubmit" and a new submittal is required (10 copies).
- C. The review of the CONTRACTOR'S submissions shall in no way relieve the CONTRACTOR of any of his responsibilities under the Contract. An acceptance of a submission shall be interpreted to mean that there are no specific objections to the submitted material, subject to conformance with the Contract Drawings and Specifications.
- D. All submissions shall be dated and properly referenced to the specifications section and Contract Drawing number. The submittal number shall match the following submittal numbering system (or an equivalent system as approved by the ENGINEER):

##### Submittal Numbering System

- 1. Package ID: The package number will reflect the CSI (specification) section number as it appears in the specifications.
- 2. Subgroup ID: The submittal number will include the CSI number followed by two additional codes. The first will define the type of submittal as follows:

- 01 Product Data, Specifications, Cut Sheets, Manufacturers certification or approval letters.
- 02 Shop Drawings
- 03 Product samples and mock-ups
- 04 Special requirements as required in the contract documents
- 05 As-Built Drawings
- 06 Warranties
- 07 O&M
- 08 Spare Parts

The second code will identify individual submittals within that submittal type. The number to the left of the decimal represents the submittal number and the number to the right of the decimal represents the revision number.

Example:

<u>Package</u>	<u>Submittal</u>	<u>Description</u>
03300	03300-01-1.1	Concrete Admixture A, First Submittal
06400	06400-01-1.2	← Re-submittal

By the following this code system, all submittals may be entered into the Document Tracking System prior to receipt of submittals. When a particular submittal is received, locate the entry in the Document Tracking project file, add the appropriate information and process. The Document Tracking System will provide the next sequence number.

- E. Shop Drawings and Project Data within practical limits shall be submitted as a single complete package for any operating system and shall include all items of equipment and mechanical units involved in the functioning of such system. Where applicable, the submission shall include elementary wiring diagrams showing circuit functioning and necessary interconnection wiring diagrams for construction.
- F. All submissions shall bear the CONTRACTOR'S stamp certifying that they have been checked for conformance and accuracy. Submissions without the CONTRACTOR'S stamp of approval will not be reviewed by the ENGINEER and will be returned to the CONTRACTOR.

- G. For any submission containing any departure from the Contract Documents and the CONTRACTOR shall include proper explanation in his letter of submittal.
- H. Work on fabricated or special items shall not be commenced until the required submission information has been reviewed and accepted.
- I. Standard items shall not be assembled or shipped until the required submission information has been reviewed and accepted.
- J. Prior review actions shall not relieve the CONTRACTOR of the responsibility for correcting errors, deviations, and/or omissions discovered at a later date.
- K. Shop Drawings: Shop Drawings include, but are not limited to, layout drawings, installation drawings, construction drawings, certified and interconnecting wiring diagrams, etc. The CONTRACTOR shall be responsible for security of all the information, details, dimension, drawings, etc. necessary to prepare submission drawings required and necessary under this Contract and to fulfill all other requirements of his Contract. The CONTRACTOR shall secure such information, details, drawings, etc. from all possible sources including the Contract Drawings, drawings prepared by subcontractors, ENGINEER, manufacturers, CONTRACTORS, etc.
- L. Submission drawings shall accurately and clearly present the following:
  - 1. All working and installation dimensions.
  - 2. Arrangement and sectional views.
  - 3. Units of equipment in the proposed position for installation, details of required attachments and connections and dimensioned locations between units and in relation to the structures.
  - 4. Necessary details and information for making connections between the various trades including but not limited to, power supplies and interconnection wiring between units, accessories, appurtenances, etc.
- M. Product Data: Where manufacturer's publications in the form of catalogs, brochures, illustrations, or other data sheets are submitted in lieu of prepared shop drawings, such submission shall specifically indicate the particular item offered. Identification of such items and relative pertinent information shall be made with indelible ink. Submissions showing only general information will not be accepted.
- N. Product data shall include materials of construction, dimensions, performance characteristics, capacities, wiring diagrams, piping and controls, etc.
- O. Samples: CONTRACTOR shall furnish for review all samples as required by the Contract Documents or requested by the ENGINEER.
- P. Samples shall be of sufficient size or quantity to clearly illustrate the quality, type, range of color, finish or texture and shall be properly labeled to show the nature of the work where the material represented by the sample will be used.

- Q. Samples shall be checked by the CONTRACTOR for conformance to the Contract Documents before being submitted to the ENGINEER and shall bear the CONTRACTOR'S stamp certifying that they have been so checked. Transportation charges on samples submitted to the ENGINEER shall be prepaid by the CONTRACTOR.
- R. ENGINEER's review will be for compliance with the Contract Documents, and his comments will be transmitted to the CONTRACTOR with reasonable promptness.
- S. Accepted samples will establish the standards by which the completed work will be judged.

#### 1.06 OPERATION AND MAINTENANCE INSTRUCTIONS (MANUALS)

- A. Individual Instructions: The CONTRACTOR , through manufacturer's representatives or other qualified individuals, shall provide instruction of designated employees of the CITY in the operation and care of all equipment furnished.
- B. Written Instructions: The CONTRACTOR shall furnish and deliver to the ENGINEER, prior to the fifty percent completion point of construction, and no later than thirty (30) days prior to operator training, ten (10) complete sets of instructions, technical bulletins, and any other printed matter such as diagrams, prints or drawings, containing full information required for the proper operation, maintenance, and repair of the equipment. As a minimum, the following shall be included in this submittal:
  - 1. Operating Instructions
  - 2. Troubleshooting Information
  - 3. Maintenance Schedule(s)
  - 4. Lubrication Schedule
  - 5. Location of Service Centers
  - 6. Parts Diagram and List
  - 7. Spare Parts List (spare parts furnished shall be defined)
  - 8. Special Tools List
  - 9. Installation Instructions
  - 10. Assembly & Erection Drawings
  - 11. Dimensional Drawings
  - 12. Wiring Diagram(s)
  - 13. Storage Instructions

- C. Availability of the O&M Manual is a prerequisite to the operation and acceptance of the system. Instructions shall be bound together in appropriate three-ring binders with a searchable electronic PDF provided, complete with Chapter bookmarks. A detailed Table of Contents shall be provided for each set. Written operation and maintenance instructions shall be required for all equipment items supplied. The amount of detail shall be commensurate with the complexity of the equipment item. They shall include all mechanical and electrical equipment such as valves, etc.
- D. Information not applicable to the specific piece of equipment installed on this project shall be struck from the submission. Information provided shall include a source of replacement parts and names of service representatives, including address and telephone number.

#### 1.07 RECORD DRAWINGS

- A. The CONTRACTOR shall keep and maintain, at the job site, one record set of Drawings. On these, it shall mark all project conditions, locations, configurations, and any other changes or deviations which may vary from the details represented on the original Contract Drawings, including buried or concealed construction and utility features which are revealed during the course of construction. Special attention shall be given to recording the horizontal and vertical location of all buried utilities that differ from the locations indicated, or which were not indicated on the Drawings. As-Built furnished grade information shall be included on the record drawings. Said record drawings shall be supplemented by detailed sketches as necessary or directed to indicate, fully, the Work as actually constructed. These master record drawings of the CONTRACTOR'S representation of as-build conditions, including all revisions made necessary by addenda and change orders shall be maintained up-to-date during the progress of Work.
- B. The record drawings shall be received on the 20th working day of every third month after the month in which the final notice to proceed is given as well as on completion of Work. Failure to maintain the record drawings up-to-date shall be grounds of withholding monthly progress payments until such time as the record drawings are brought up-to-date.
- C. In the case of those drawings which depict the detail requirement for equipment to the assembled and wired in the factory, such as motor control centers and the like, the record drawing shall be updated by indicating those portions which are superseded by change order drawings or final shop drawings, and by including appropriate reference information describing the change orders by number and the shop drawings by manufacturer, drawing, and revision numbers.
- D. Record drawings shall be accessible to the ENGINEER at all times during the construction period.
- E. Final payment will not be acted upon until the CONTRACTOR prepared record drawings have been delivered to the ENGINEER. Said up-to-date record drawings shall be in the form of a set of prints with carefully plotted information overlaid in pencil.
- F. Upon substantial completion of the Work and prior to final acceptance, the CONTRACTOR shall finalize and deliver a complete set of record drawings to the

ENGINEER for transmittal to the CITY, conforming to the construction records of the CONTRACTOR. This set of drawings shall consist of corrected drawings showing the reported location of the Work. The information submitted by the CONTRACTOR and incorporated in the Record Drawings will be assumed to be correct, and the ENGINEER will not be responsible for the accuracy of such information, and for any errors or omissions which may appear on the Record Drawings as a result.

- G. The information submitted by the CONTRACTOR in the record drawings shall be certified by a land surveyor registered in the State of Florida.
- H. The record drawings shall show the exact location of all structures and all mains within the right-of-way or easement, size and type of material of mains, all deflection points (vertical and horizontal), top pipe elevations and stationing at 100-foot increments, and exact dimensions and locations of all fittings and valves.

#### 1.08 WARRANTIES

- A. Original warranties, called for in the Contract Documents, shall be submitted to the CITY through the ENGINEER. When warranties are required, they shall be submitted prior to request for payment.
- B. When advance copies of warranties are requested, they shall be submitted with, and considered as shop drawings.
- C. The CONTRACTOR shall warrant to the CITY that all material and labor used in the construction are covered by his warrantee for a minimum of a one year period upon approval and acceptance by the CITY. The CONTRACTOR shall replace or repair defects at no cost to the CITY during the warrantee period. No visible or potential leakage shall be allowed during the warrantee period.

#### 1.09 CERTIFICATES

- A. Copies of certificates of compliance and test reports shall be submitted for requested items to the ENGINEER prior to request for payment.

#### 1.10 AUDIO-VISUAL PRECONSTRUCTION RECORD

- A. General: Prior to commencing work, the CONTRACTOR shall have a continuous color audio-video digital video recording taken of the entire Project, including adjacent work areas, plant site and all other areas that will be disturbed by the Contractor's operations, to serve as a record of preconstruction conditions. No construction shall begin prior to review and acceptance of the discs covering the respective, affected construction area by the ENGINEER. The ENGINEER shall have the authority to reject all or any portion of the recording not conforming to the specifications and order that it be redone at no additional charge. The CONTRACTOR shall reschedule unacceptable coverage within five days after being notified. The ENGINEER shall designate those areas, if any, to be omitted from or added to the audio-video coverage. Recordings shall not be performed more than ninety days prior to construction in any area. Recording format shall be MP4 audio-video, minimum 1280 x 720 resolution, and playable using Windows Media Player. CONTRACTOR shall submit MP4 video via three (3) flash

drives. CDs and/or DVDs will not be accepted. All flash drives and written records shall become property of the City.

- B. Services: The CONTRACTOR shall engage the services of a professional electrographer. The color video shall be prepared by a responsible commercial firm known to be skilled and regularly engaged in the business of preconstruction color audio-video video documentation. The electrographer shall furnish to the ENGINEER a list of all equipment to be used for the audio-video recording, i.e., manufacturer's name, model number, specifications and other pertinent information. Additional information to be furnished by the electrographer is the names and addresses of two references that the electrographer has performed color audio-video recordings for on projects of a similar nature within the last twelve months.
- C. Equipment: All equipment, accessories, materials and labor to perform this service shall be furnished by the CONTRACTOR.
1. The total audio-video system shall reproduce bright, sharp, clear pictures with accurate colors and shall be free from distortion, tearing, rolls or any other form of imperfection. The audio portion of the recording shall reproduce the commentary of the camera operator with proper volume and clarity, and be free from distortion and interruptions.
  2. When conventional wheeled vehicles are used, the distance from the camera lens to the ground shall not be less than twelve feet. In some instances, audio-video coverage may be required in areas not accessible by conventional wheeled vehicles. Such coverage shall be obtained by walking or special conveyance acceptable to the ENGINEER.
  3. The color video camera used in the recording system shall have a horizontal resolution of 300 lines at center, a luminance signal to noise ratio of 45 dB and a minimum illumination requirement of twenty-five foot-candles.
- E. Recorded Information - Audio: Each disc shall begin with the current date, project name and municipality and be followed by the general location; i.e., process structure, or area, viewing side and direction of progress. The audio track shall consist of an original live recording. The recording shall contain the narrative commentary of the electrographer, recorded simultaneously with his fixed elevation video record of the zone of influence of construction.
- F. Recorded Information - Video: All video recordings must, by electronic means, display continuously and simultaneously, generated with the actual recording, transparent digital information to include the date and time of recording. The date information shall contain the month, day and year. The time information shall contain the hours, minutes, and seconds. Additional information shall be displayed periodically. Such information shall include, but not be limited to, project name, process structure or area, and the viewing side. This transparent information shall appear on the extreme upper left hand third of the screen.
- G. Conditions for Recording: All recording shall be done during times of good visibility. No recording shall be done during precipitation, mist or fog. The recording shall only be

done when sufficient sunlight is present to properly illuminate the subjects of recordings and to produce bright, sharp video recordings of those subjects.

- H. Video Coverage: Video coverage shall include all surface features located within the zone of influence of construction supported by appropriate audio coverage. Such coverage shall include, but not be limited to, existing driveways, sidewalks, curbs, pavement, landscaping, fences, signs and interior and exterior of existing structures affected by the work and the exteriors of structures adjacent to the work, and any other on-site area that will be occupied or impacted by the CONTRACTOR or any of his subcontractors or suppliers within the area covered.

#### 1.11 PROJECT PHOTOGRAPHS

- A. The CONTRACTOR shall engage and pay for the services of a professional photographer for ground level progress pictures each month during the course of the construction activities. The photographer's periodic visits and work shall be coordinated with the CITY. A total of 12 progress photographs in electronic format of completed work is required each month. A photograph (picture) shall be defined as one exposure. Meta data shall include the following information:

1. Name of Facility
2. Name/number of Structure
3. Photo Number
4. Date picture was taken
5. Description
6. Name of photographer
7. Owner's witness

PART 2 -- PRODUCTS (Not Used)

PART 3 -- EXECUTION (Not Used)

- END OF SECTION -



## SECTION 01400 - TESTING AND INSPECTION

### PART 1 -- GENERAL

- A. All testing and inspection will be in accordance with Article 12 of the General Conditions.
- B. The work or actions of the testing laboratory shall in no way relieve the CONTRACTOR of his obligations under the Contract. The laboratory testing work will include such inspections and testing required by the Contract Documents, existing laws, codes, ordinances, etc. The testing laboratory will have no authority to change the requirements of the Contract Documents, nor perform or approve any of the CONTRACTOR'S work.
- C. The CONTRACTOR shall allow the ENGINEER ample time and opportunity for testing materials and equipment to be used in the work. He shall advise the ENGINEER promptly upon placing orders for materials and equipment so that arrangements may be made, if desired, for inspection before shipment from the place of manufacture. The CONTRACTOR shall at all times furnish the ENGINEER and his representatives, facilities including labor, and allow proper time for inspecting and testing materials, equipment, and workmanship. The CONTRACTOR must anticipate that possible delays may be caused him in the execution of his work due to the necessity of materials and equipment being inspected and accepted for use. The CONTRACTOR shall furnish, at his own expense, all samples of materials required by the ENGINEER for testing, and shall make his own arrangement for providing water, electric power, or fuel for the various inspections and tests of structures and equipment. As a minimum, 24-hours advance written notice shall be provided by the CONTRACTOR for rebar, structural and similar inspections by the ENGINEER. The amount of time required for advance written notice by the CONTRACTOR to the ENGINEER for other inspections depends upon other factors and shall be solely at the ENGINEER'S discretion.
- D. The CONTRACTOR shall furnish the services of representatives of the manufacturers of certain equipment, as prescribed in other sections of the Specifications. The CONTRACTOR shall also place his orders for such equipment on the basis that, after the equipment has been tested prior to final acceptance of the work, the manufacturer will furnish to the CITY the certified statements that the equipment has been installed properly and is ready to be placed in functional operation. Tests and analyses required of equipment shall be paid for by the CONTRACTOR, unless specified otherwise in the section which covers a particular piece of equipment.
- E. The CITY will bear the cost of all additional tests, inspections, or investigations undertaken by the order of the ENGINEER for the purpose of determining conformance with the Contract Documents if such test, inspection, or investigations are not specifically required by the Contract Documents, and if conformance is ascertained thereby. Whenever nonconformance is determined by the ENGINEER as a result of such test, inspections, or investigations, the CONTRACTOR shall bear the full cost thereof or shall reimburse the CITY for said cost. The cost of any additional tests and investigations, which are ordered by the ENGINEER to ascertain subsequent conformance with the Contract Documents, shall be borne by the CONTRACTOR.

PART 2 -- PRODUCTS (Not Used)

PART 3 -- EXECUTION (Not Used)

- END OF SECTION -

## SECTION 01500 - CONSTRUCTION CONSIDERATIONS

### PART 1 -- GENERAL

#### 1.01 HYDRAULIC UPLIFT ON STRUCTURES

- A. The CONTRACTOR shall be completely responsible for any tanks, wet wells, pipelines, manholes, foundations, cellars, or similar structures that may become buoyant during the construction operations due to the ground water, floods or buoyancy of piping caused due to the placement of flowable backfills before the structure is put into operation. Should there be any possibility of buoyancy of a pipeline or structure, the CONTRACTOR shall take the necessary steps to prevent its buoyancy. Damage to any structures due to floating or flooding shall be repaired or the structures replaced at the CONTRACTOR'S expense.

#### 1.02 WATER TIGHTNESS OF STRUCTURES

- A. General: It is the intent of these specifications that all concrete work, sealing work around built-in items and penetrations be performed as required to ensure that groundwater, rainwater, wastewater, chemical solutions or other process liquids in tanks, wetwells, channels, and containers will not leak into any buildings and/or equipment rooms, pipe galleries, habitable areas, or other generally dry areas.
  - 1. The required watertightness shall be achieved by quality concrete construction and proper sealing of all joints and penetrations.
  - 2. Each unit shall be tested separately, and the leakage tests shall be made prior to backfilling and before equipment is installed unless otherwise approved by the ENGINEER.
  - 3. The CONTRACTOR shall provide at his own expense all labor, material, temporary bulkheads, pumps, water, measuring devices, etc., necessary to perform the required test.
- B. Built-in Items and Penetrations: All pipe sleeves, built-in items and penetrations shall be sealed as detailed and as required to ensure a continuous watertight seal.

#### 1.03 CUTTING AND PATCHING

- A. The CONTRACTOR shall perform all cutting and patching of his work that may be required to make its several parts come together properly and fit it to receive or be received by such other work. The CONTRACTOR shall not endanger any work of others by cutting, excavating or otherwise altering their work and shall only cut or alter work with the written consent of the ENGINEER and of the other contractors whose work will be affected.

#### 1.04 ABANDONMENT AND SALVAGE OF EXISTING FACILITIES

- A. General: The scope of work requires the CONTRACTOR to interface with existing structures, and piping which will be abandoned or otherwise removed and/or relocated

as part of the work. Prior to beginning any work associated with existing facilities to be abandoned, salvaged, or otherwise removed or relocated, the CONTRACTOR shall inform the CITY and the ENGINEER of his intent so that all arrangements can be made with the CITY for isolating pipelines (where possible) or otherwise removing existing facilities from service to the extent possible. The CONTRACTOR shall not proceed without written authorization from the CITY.

- B. Pipelines: The CONTRACTOR shall abandon, salvage or otherwise remove existing pipelines or segments of existing pipelines shown to be abandoned in place, salvaged, or removed as part of the contract work. Unless otherwise indicated in the Contract Documents, all piping shown on the Drawings to be abandoned shall be abandoned in place. Pipe shown to be abandoned need only be removed a minimum three feet clear of new utilities to be installed. Abandon-in-place shall be defined as installing plugs, or other permanent closure, as reviewed and accepted by the CITY, on all termination's, open ends or ends of pipe designated as being cut, capped and anchored in an acceptable manner. The pipe will remain buried unless otherwise noted.
- C. Piping indicated on the Drawings as being removed, or any piping to be abandoned which interferes with new structures or piping, shall be excavated and removed using methods which will not disturb adjacent piping or other facilities. All pipe materials shall be subject to salvage by the CITY as defined below. Any remaining piping on both ends of pipe segments removed shall be abandoned in-place, per the above definition. After piping has been removed, the CONTRACTOR shall backfill the excavated area in accordance with requirements set forth in other sections of these specifications.
- D. Equipment: The CONTRACTOR shall abandon, salvage or otherwise remove existing equipment or other facilities as shown on the Contract Drawings or indicated herein. In all cases, the CONTRACTOR shall exercise caution when handling the existing equipment so as not to disturb or damage adjacent facilities. The CONTRACTOR shall make all repairs to adjacent facilities which may be damaged as a result of the CONTRACTOR's efforts in abandoning, salvaging or otherwise removing existing facilities, at no additional cost to the CITY.
- E. Salvage: The CITY may desire to salvage certain items of existing equipment which are to be dismantled and removed during the course of construction. Prior to removal of any existing equipment or piping from the site of work, the CONTRACTOR shall ascertain from the CITY whether or not the particular item or items are to be salvaged. Items to be salvaged shall be stockpiled on the site, in a location as designated by the CITY. All other items of equipment shall be disposed of off-site by the CONTRACTOR at his own expense, in accordance with applicable laws, ordinances and regulations.

#### 1.05 DIMENSIONS OF EXISTING STRUCTURES

- A. Where the dimensions and locations of existing structures are of critical importance in the installation or connection of new work, the CONTRACTOR shall verify such dimensions and locations in the field before the fabrication of any materials or equipment which is dependent on the correctness of such information.

## 1.06 REHABILITATION

- A. Certain areas of existing structures, piping, conduits, and the like will be affected by work necessary to complete modifications under this Contract. The CONTRACTOR shall be responsible to rehabilitate those areas affected by its construction activities.
- B. Where new rectangular openings are to be installed in concrete or concrete masonry walls or floors, the CONTRACTOR shall score the edges of each opening (both sides of wall or elevated slab) by saw cutting clean straight lines to a minimum depth of one inch and then chipping out the concrete. Alternately, the opening can be formed by saw cutting completely through the slab or wall. Saw cuts deeper than one inch (or the depth of cover over existing reinforcing steel, whichever is less) shall not be allowed to extend beyond the limits of the opening. Corners shall be made square and true by a combination of core drilling, chipping, or grinding. All necessary precautions shall be taken during removal of concrete to prevent debris from falling and damaging adjacent equipment or piping. Saw cuts allowed to extend beyond the opening shall be repaired by filling with nonshrink grout. The concrete around any exposed reinforcement steel shall be chipped back and exposed reinforcement steel cut a minimum of 1-1/2 inches from the finished face of the new opening. The inside face of the new opening shall be grout to fill any voids and cover the exposed aggregate and shall be trowel-finished to provide a plumb and square opening.
- C. Where new piping is to be connected to existing piping, the existing piping shall be cut square and the ends properly prepared for the connection shown on the drawings. Any damage to the lining and coating of the existing piping shall be repaired by the CONTRACTOR.
- D. Where existing equipment, equipment pads and bases, piping, piping supports, electrical panels and devices, conduits, and associated appurtenances are removed, the CONTRACTOR shall rehabilitate the affected area such that little or no evidence of the previous installation remains. Opening in concrete floors, walls, and ceiling from piping, conduit, and fastener penetrations shall be filled with nonshrink grout and finished to match the adjacent area. Concrete pads and bases for equipment and supports shall be removed by chipping away concrete and cutting any exposed reinforced steel and anchor bolts a minimum of 1-1/2 inches below finished grade. The area of concrete to be rehabilitated shall be scored by saw cutting clean, straight lines to a minimum depth of 1-1/2 inches, and all concrete within the scored lines removed to a minimum depth of 1-1/2 inches. The area within the scored lines shall be patched with nonshrink grout to match the adjacent grade and finish. Abandoned connections to piping and conduits shall be terminated with blind flanges, caps, and plugs suited for the material, type, and service of the pipe or conduit.
- E. Where existing structural steel members are removed or modified, the surface of the remaining existing steel members damaged by construction activities shall be repaired. The affected areas shall be surface prepared and coated in accordance with Division 9.
- F. Disposal of Debris: All debris, materials, piping, and miscellaneous waste products from the work described in this section shall be removed from the project as soon as possible. They shall be disposed of in accordance with applicable federal, state, and local regulations. The CONTRACTOR is responsible for determining these regulations and shall bear all costs or retain any profit associated with disposal of these items.

#### 1.07 INSTALLATION OF EQUIPMENT

- A. CONTRACTOR shall have on hand sufficient personnel, proper equipment, and machinery of ample capacity to facilitate the work.
- B. CONTRACTOR shall be responsible for locating, aligning and leveling all equipment and shall employ a licensed surveyor to set all lines and levels of equipment to the accuracy required.
- C. Complete manufacturers installation instructions, including permissible tolerances, shall be furnished in duplicate with each unit of equipment or set of identical units.
- D. All equipment shall be installed in accordance with the shop drawings; inclusive of manufacturer's specifications, drawings and tolerances; under the direct supervision of the required manufacturer's ENGINEER. No instructions shall be issued that are contrary to written specifications without prior written approval by the CITY's ENGINEER.
- E. Equipment shall be erected in a neat and workmanlike manner on the foundations at the locations and elevations shown on the drawings unless otherwise indicated by the ENGINEER during installation.

#### 1.08 SUPERVISION BY MANUFACTURER'S REPRESENTATIVES

- A. The CONTRACTOR shall provide the services of qualified equipment manufacturer's technical representatives who shall adequately supervise the installation and testing of all equipment furnished under this Contract and instruct the CONTRACTOR's personnel and CITY's operating personnel in its maintenance and operation.

#### 1.09 EQUIPMENT MANUFACTURER'S CERTIFICATION

- A. As a condition precedent to acceptance of equipment installed and operating, the CONTRACTOR will provide the CITY with written certification, obtained from each company manufacturing equipment for the Project, that the equipment is installed and does operate in accordance with the specifications and manufacturer's recommendations.

#### 1.10 SLEEVES AND OPENINGS

- A. The CONTRACTOR shall provide all openings, chases, etc., to fit his own work and that of any other subcontractors and contractors. All such openings or chases shown on the Contract Drawings, or reasonably implied thereby, or as confirmed or modified by shop, setting or erecting drawings approved by the ENGINEER, shall be provided by the CONTRACTOR.
- B. Where pipes or conduits are to pass through slabs or walls, or where equipment frames or supports are to be installed as integral part of an opening, the sleeves, opening, forms or frames shall be furnished by the installer of the pipes, conduits or equipment, but shall be placed by the CONTRACTOR.

- C. Where hanger inserts, anchor bolts and similar items are to be embedded in concrete as an integral part of a slab or wall, they shall be furnished by the installer of the pipe or other equipment requiring the hanger, etc. but shall be placed by the CONTRACTOR.
- D. When requested by the CONTRACTOR, the installer of the pipes, conduit, or equipment, including those contractors or subcontractors who require openings or chases in slabs and walls for passage of ducts, mounting or equipment, etc., shall furnish all necessary information, instructions, and materials to effect accurate installation of the required openings, chases, sleeves, frames, inserts, etc. When such items are secured in position, and just prior to construction of the surrounding slab or wall, the subcontractor or contractor for whom the items are installed shall ascertain the proper number, locations, and settings thereof; and the CONTRACTOR shall schedule his operations so as to provide a reasonable opportunity and time interval for such inspection.
- E. Any cost resulting from correction of defective, ill-timed, or mislocated work, or for subsequent work which becomes necessary because of omitted openings, chases, sleeves, frames, inserts, etc., shall be borne by the subcontractor or contractor responsible therefor. No contractor or subcontractor shall arbitrarily cut, drill, alter, damage, or otherwise endanger the work of another Contractor. In no case shall beams lintels, or other structural members be cut without the approval of the ENGINEER. The nature and extent of any corrective or additional work shall be subject to the approval of the ENGINEER following consultation with the affected parties.

#### 1.11 OBSTRUCTIONS

- A. All water pipes, storm drains, sanitary sewers, force mains, gas or other pipe, telephone or power cables or conduits and all other obstructions, whether or not shown, shall be temporarily supported across utility line excavations. The CONTRACTOR shall be responsible for any damage to any such pipes, conduits, or structures. Approximate locations of known water, sanitary, drainage, power and telephone installations along route of new pipelines or in the vicinity of new work are shown, but must be verified in the field by the CONTRACTOR. The CONTRACTOR shall uncover these pipes, ducts, cables, etc., carefully, by hand, prior to installing new lines. Any discrepancies or differences found shall be brought to the attention of the ENGINEER in order that necessary changes may be made to permit installation of new work. These conditions are supplemental to general requirements elsewhere in the Contract Documents.

#### 1.12 SITE CONDITIONS

- A. The CONTRACTOR acknowledges that he has investigated prior to bidding and satisfied himself as to the conditions affecting the Work, including but not restricted to those bearing upon transportation, disposal, handling and storage of materials, availability of labor, water, electric power, roads and uncertainties of weather, canal stages, tides, water tables or similar physical conditions at the site, the conformation and conditions of the ground, the character of equipment and facilities needed preliminary to and during prosecution of the Work. The CONTRACTOR further acknowledges that he has satisfied himself as to the character, quality and quantity of surface and subsurface materials or obstacles to be encountered insofar as this information is reasonably ascertainable from an inspection of the site, or any contiguous site, as well as from information presented by the Drawings and

Specifications made a part of this Contract, or any other information made available to him prior to receipt of Bids. Any failure by the CONTRACTOR to acquaint himself with the available information will not relieve him from responsibility for estimating properly the difficulty or cost of successfully performing the Work. The CITY assumes no responsibility for any conclusions or interpretations made by the CONTRACTOR on the basis of the information made available by the CITY.

#### 1.13 SUBSURFACE INVESTIGATIONS

- A. The CONTRACTOR shall be responsible for having determined to his satisfaction, prior to the submission of his bid, the nature and location of the work, the conformation of the ground, the character and quality of the substrata, the types and quantity of materials to be encountered, the nature of the groundwater condition, the character of equipment and facilities required preliminary to and during the performance of the work, the general and local conditions and all other matters which can in any way affect the work under this Contract. The prices established for the work to be done shall reflect all costs pertaining to the work. Any claims for extras based on the substrata or ground water table conditions will be disallowed.
- B. Subsurface data are offered in good faith solely for placing the CONTRACTOR in receipt of all information available to the CITY and ENGINEER and in no event is to be considered as part of the Contract Documents. The CONTRACTOR shall interpret such sub-surface data according to his own judgment and not rely upon the same as accurately describing the sub-surface conditions, which may be found to exist.
- C. The CONTRACTOR further acknowledges that he assumes all risk contingent upon the nature of the subsurface conditions actually encountered by him in performing the work covered by the Contract, even though such actual conditions may result in the CONTRACTOR performing more or less work than he originally anticipated.
- D. In making these data available, the CITY makes no guarantee, either expressed or implied, as to their accuracy or to the accuracy of any interpretation thereof.

#### 1.14 DIFFERING SITE CONDITIONS

- A. The CONTRACTOR shall promptly and before such conditions are disturbed, notify the CITY in writing of: (1) subsurface or latent physical conditions at the site differing materially from those indicated in this contract, or (2) unknown physical conditions at the site, of an unusual nature, differing materially from those ordinarily encountered and generally recognized as inherent in work of the character provided for this contract. The CITY will promptly investigate the conditions, and if he finds that such conditions do materially so differ and cause an increase or decrease in the CONTRACTOR's cost of, or the time required for, performance of any part of the work under this contract, whether or not changed as a result of such conditions, an equitable adjustment shall be made and the contract modified in writing accordingly

#### 1.15 PROTECTION OF PROPERTY

- A. The CONTRACTOR shall protect all property that may be affected by his work or operations. The location and extent of underground and covered facilities are not



guaranteed and the CONTRACTOR is cautioned to proceed with care in order to prevent the undermining or damage to existing structures, piping, or facilities.

- B. The CONTRACTOR shall take all measures necessary to protect new and existing mechanical equipment from dust and debris. All protective measures shall be furnished, installed, lighted, ventilated, maintained, and removed at the CONTRACTOR'S own cost.
- C. When CITY water is being used, the supply source shall be protected against contamination in accordance with existing codes and regulations.
- D. In the event any of the CONTRACTOR'S activities were to disrupt or endanger any facilities, he shall at his own expense make all necessary repairs or replacements necessary to correct the situation to the satisfaction of the ENGINEER. Such work shall progress continuously to completion on a 24-hour per day, seven workday basis. The CONTRACTOR shall be responsible for the services of repair crews on call 24 hours per day for emergencies that arise involving work under this Contract.

#### 1.16 WEATHER CONDITIONS

- A. Work that may be affected by inclement weather shall be suspended until proper conditions prevail. In the event of impending storms the CONTRACTOR shall take necessary precautions to protect all work, materials and equipment from exposure. The CITY reserves the right, through the opinion of the ENGINEER, to order that additional protection measures over and beyond those proposed by the CONTRACTOR, be taken to safeguard all components of the project. The CONTRACTOR shall not claim any compensation for such precautionary measures so ordered, nor claim any compensation from the CITY for damage to the work from the elements of weather.

#### 1.17 FIRE PROTECTION

- A. The CONTRACTOR shall take all necessary precautions to prevent fires at or adjacent to the work, including his own buildings and trailers. Adequate fire extinguisher and hose line stations shall be provided throughout the work area.

#### 1.18 SAFETY AND HEALTH REQUIREMENTS

- A. The CONTRACTOR shall comply in every respect with all Federal, State and local safety and health regulations. Copies of the Federal Regulations may be obtained from the U.S. Department of Labor, Occupational Safety and Health Administration, 3200 East Oakland Park Boulevard, Room 204, Bridge Building, Fort Lauderdale, Florida 33300.
- B. The CONTRACTOR shall provide all barricades and flashing warning lights or other devices necessary to warn pedestrians and area traffic.
- C. Personnel working in contact with sewage flow or surfaces carrying wastewaters or sludges shall be immunized as recommended by the Broward County Health Department.

### PART 2 -- PRODUCTS (Not Used)

PART 3 -- EXECUTION (Not Used)

- END OF SECTION -

## SECTION 01510 - TEMPORARY UTILITIES

### PART 1 -- GENERAL

#### 1.01 THE REQUIREMENT

- A. The CONTRACTOR shall provide temporary telephone, light and power, heating and air conditioning, potable water service and sanitary facilities for their operations and for the construction operations of the other subcontractors of this Project at the site. The temporary services shall be provided for use throughout the construction period.
- B. The CONTRACTOR shall coordinate and install all temporary services in accordance with the requirements of the utility companies having jurisdiction and as required by applicable codes and regulations.
- C. At the completion of the work, or when the temporary services are no longer required, the facilities shall be restored to their original conditions.
- D. All costs in connection with the temporary services including, but not limited to, installation, utility company service charges, maintenance, relocation and removal shall be borne by the CONTRACTOR at no additional cost to the CITY.
- E. Some temporary facilities that may be required may be indicated on the Drawings; however, the Drawings do not necessarily show any or all of the temporary facilities that the CONTRACTOR ultimately uses to complete the work.
- F. Temporary Light and Power
  - 1. The temporary general lighting and small power requirements shall be serviced by 120/240 V, 1 phase, 3 wire temporary systems furnished and installed by the CONTRACTOR. This service shall be furnished complete with step down transformer, main disconnect, overcurrent protection, branch circuit breakers, and wiring as required; including branch circuit breakers and wiring as required for furnishing temporary power to the various connections required by the CONTRACTOR, all in accordance with the requirements of the servicing power company and applicable standards and codes. Connection to the plant emergency power system is prohibited. CITY shall not be responsible for CONTRACTOR loss of power in the event of a power interruption caused by the power company or any other event which may cause an interruption in service to the temporary light and power system. Any CONTRACTOR with a need for power other than the 120/240 V, 1 phase, 3 wire shall provide such power at their own expense.
  - 2. The CONTRACTOR shall make all necessary arrangements, and pay for all permits, inspections, and other charges for all temporary service installations. All temporary systems shall comply with and meet the approval of the ENGINEER, CITY and the local authorities having jurisdiction. All temporary electrical systems shall consist of wiring, switches, necessary insulated supports, poles, fixtures, sockets, receptacles, lamps, guards, cutouts, and fuses as required to complete such installations. The CONTRACTOR shall furnish lamps and fuses for all temporary systems furnished by

him and shall replace broken and burned out lamps, blown fuses, damaged wiring and as required to maintain these systems in adequate and safe operating condition. All such temporary light and power system shall be installed without interfering with the work of the other CONTRACTORS.

When it is necessary during the progress of construction that a temporary electrical facility installed under this Division interferes with construction operations, the CONTRACTOR shall relocate the temporary electrical facilities to maintain temporary power as required at no additional cost to the CITY. The CONTRACTOR shall be responsible at all times for any damage or injury to equipment, materials, or personnel caused by improperly protected or installed temporary installations and equipment.

3. The various CONTRACTORS doing the work at the site shall be permitted to connect into the temporary general lighting system small hand tools, such as drills, hammers, and grinders, provided that:
  - a. Equipment and tools are suitable for 120 V, single phase, 60 Hz operation and operating input does not exceed 1,500 volt-amperes.
  - b. Tools are connected to outlets of the system with only one (1) unit connected to a single outlet.
  - c. In case of overloading of circuits, the CONTRACTOR will restrict use of equipment and tools as required for correct loading.
4. The CONTRACTOR shall keep the temporary general lighting systems energized 15 minutes before the time that the earliest trade starts in the morning and de-energized 15 minutes after the time the latest trade stops. This applies to all weekdays, Monday through Friday, inclusive, which are established as regular working days.

Any CONTRACTOR requiring temporary light and power before or after the hours set forth hereinbefore, or on a Saturday, Sunday, or holiday, shall pay for the additional cost of keeping the system energized and repaired. If more than one CONTRACTOR is involved, the charges shall be prorated, such amounts to be determined from the meter readings or other acceptable means previously agreed upon by the CONTRACTORS involved. If it is necessary for any CONTRACTOR or his employees to be in any structure after regular working hours and the temporary general lighting system is not required for illumination, that CONTRACTOR shall provide such illumination required by means of flashlights, electric lanterns, or other devices not requiring use of electricity from the temporary general lighting system.

5. Each CONTRACTOR requiring additional power and lighting other than that specified herein (including power for temporary heating equipment to be provided by the CONTRACTOR) shall furnish his own service complete with all fuses, cutouts, wiring and other material and equipment necessary for a complete system between the service point and the additional power consumers and shall install his own metering equipment in accordance with the requirements of the servicing power company.

6. The temporary general lighting system shall be installed progressively in structures as the various areas are enclosed or as lighting becomes necessary because of partial enclosure. Lighting intensities shall be not less than 10 foot candles.
7. The CONTRACTOR shall provide a separate temporary night lighting circuit for construction security. This system shall be energized at the end of each normal working day and de-energized at the start of each normal working day by the CONTRACTOR. The system is to be left energized over Saturdays, Sundays, and all holidays. Lighting intensities shall be not less than 2 foot candles.
8. Electrical welders provided by each trade used in the erection and fabrication of the buildings, structures and equipment shall be provided with an independent grounding cable connected directly to the structure on which the weld is being made rather than adjacent conduit piping, etc.

Electricians and other tradesmen necessary for the required connections and operation of welding equipment and generator, standby generators and similar equipment shall be furnished by the individual CONTRACTORS. All costs for such labor and equipment shall be borne by the individual CONTRACTORS.

9. Upon completion of the work, but prior to acceptance by the CITY, the CONTRACTOR shall remove all temporary services, security lighting systems, temporary general lighting systems and all temporary electrical work from the premises.

#### G. Temporary Heating and Air Conditioning

1. The CONTRACTOR shall provide temporary heating, air conditioning, ventilation coverings and enclosures necessary to properly protect all work and materials against damage by dampness, heat and/or cold, to dry out the work and to facilitate work in all structures.
2. The equipment, fuel, materials, operating personnel and methods used shall be at all times satisfactory and adequate to maintain critical installation temperatures and ventilation for all work in those areas where the same is required.
3. After any structure is enclosed, the minimum temperature to be maintained is 50 degrees Fahrenheit, unless otherwise specified, where work is actually being performed.
4. Before and during the application of interior finishing, painting, etc., the CONTRACTOR shall provide sufficient heat to maintain a temperature of not less than 65 degrees Fahrenheit or greater than 85 degrees Fahrenheit.
5. Any work damaged by dampness or insufficient or abnormal heating shall be replaced by the CONTRACTOR at no additional cost to the CITY.

#### H. Temporary Sanitary Service

1. Sanitary conveniences, in sufficient numbers, for the use of all persons employed on the work and properly screened from public observation, shall be provided and

maintained at suitable locations by the CONTRACTOR, all as prescribed by State Labor Regulations and local ordinances. The contents of same shall be removed and disposed of in a manner consistent with local and state regulations, as the occasion requires. Each CONTRACTOR shall rigorously prohibit the committing of nuisances within, on, or about the work. Sanitary facilities shall be removed from the site when no longer required.

I. Temporary Water

1. The CONTRACTOR shall provide temporary potable water service for construction purposes, sanitary facilities, fire protection, field offices and for cleaning. The CONTRACTOR shall make all arrangements for connections to the potable water at the plant site. The CONTRACTOR shall obtain a potable water flowmeter from the Department of Public Utilities at the CITY of Hollywood.
2. The CONTRACTOR shall pay all charges associated with the potable water connection. The CONTRACTOR shall pay all charges for potable water used under this Contract.
3. Each CONTRACTOR shall supply potable water for his employees either by portable containers or drinking fountains.
4. An adequate number of hose bibbs, hoses, and watertight barrels shall be provided for the distribution of water.
5. Water service shall be extended by the CONTRACTOR and relocated as necessary to meet temporary water requirements.

J. Confined Spaces

1. The CONTRACTOR shall provide and maintain a safe working environment in confined spaces. The CONTRACTOR shall follow the applicable requirements of the OSHA Standards for Construction and NIOSH Publications for working in confined spaces.

PART 2 -- PRODUCTS (Not Used)

PART 3 -- EXECUTION (Not Used)

- END OF SECTION -

## SECTION 01520 - MAINTENANCE OF FACILITIES AND SEQUENCE OF CONSTRUCTION

### PART 1 -- GENERAL

#### 1.01 GENERAL

- A. The City of Hollywood's Southern Regional Wastewater Treatment Plant will be maintained in continuous operation during the entire period of the Contract as hereinafter specified. Clarifier No. 3 is currently out of service as specified herein. The intent of this specification is to outline the requirements to provide continuous treatment throughout the construction period.
- B. The CONTRACTOR has the option of providing additional temporary facilities that can eliminate a constraint, provided it is done without cost to the CITY (including additional CITY labor) and provided that all requirements of these Specifications are fulfilled. Work not specifically covered in the following paragraphs may, in general, be done at any time during the contract period, subject to the operating requirements and constraints and construction requirements outlined hereinafter. All references to days in this Section shall be consecutive calendar days.

#### 1.02 CONSTRUCTION SCHEDULE

- A. The construction schedule shall be submitted by the CONTRACTOR in accordance with Section 01300 of these Specifications.

#### 1.03 USE OF FACILITIES BEFORE COMPLETION

- A. The CITY reserves the right to enter and use any portion of the constructed facilities before final completion of the whole work to be done under this Contract in accordance with Article 14.2 Partial Utilization, of the General Conditions.

#### 1.04 CONNECTION OF EXISTING SYSTEMS

- A. All connections to existing systems shall be performed in such a manner that no damage and minimal interruption is caused to the existing installation. On completion of its installation, the CONTRACTOR shall complete the connection to the existing systems in a proper manner. Any damage caused to existing installations shall be repaired or replaced by the CONTRACTOR at no additional cost to the CITY.
- B. The CONTRACTOR shall note that some of the work in this Contract will require the CONTRACTOR to connect to existing pipelines and structures. The CONTRACTOR shall be responsible for the proper containment and disposal of wastewater or other materials drained from existing pipelines and structures during construction, unless otherwise specifically noted to be performed by the CITY.
- C. The CONTRACTOR shall contain such wastewater or other materials (in accordance with all applicable codes) and shall dispose of such within the existing treatment system as approved by the CITY. The CONTRACTOR shall be responsible for the prevention of wastewater or other material spills within the Work.

## 1.05 COORDINATION WITH UTILITY PERSONNEL

- A. Before commencing work involving removing or placing in operation existing or new facilities or tie-ins to existing facilities, the CONTRACTOR shall notify the CITY at least ten (10) days in advance in writing. The CITY shall be responsible for removing facilities from operation as deemed necessary.
- B. Only the CITY's appointed representative can authorize the shutdown of portions of the treatment plant facilities. The CONTRACTOR shall, under no circumstances, interfere with any treatment plant facility component without the CITY's authorization, in writing, and supervision. The CONTRACTOR shall notify the CITY's representative in writing a minimum of three work days prior to each scheduled service request. This notification shall be provided on the CITY's standard form, or on an approved equivalent form completed in full by the CONTRACTOR.

## 1.06 GENERAL CONSTRAINTS

- A. Work under the Contract shall be scheduled and performed in such a manner as to result in the least possible disruption to the operation of the treatment plant facilities and to the public's use of roadways, driveways, parking areas, and utilities. Utilities shall include but not be limited to water, sewerage, irrigation, drainage structures, gas, electrical service and telephone. Prior to commencing with the work, CONTRACTOR shall perform a location investigation of existing underground utilities and facilities in accordance with Section 01530 entitled "Protection of Existing Facilities".
- B. All work by the CONTRACTOR that disrupts the normal treatment plant operations shall be shown on the Construction Schedule specified in Section 01300 and specifically scheduled with the CITY. Schedule notification shall consist of a written notice defining the work to be accomplished, the normal functions that will be interrupted, the duration of the interruption, and the mitigating effort to be performed by the CONTRACTOR. The written notice shall be submitted to the CITY ten (10) days in advance of the proposed work and the CITY will respond to the CONTRACTOR in writing within five (5) days of receipt of the notice regarding the acceptability of the proposed plan.
- C. At no time shall the CONTRACTOR undertake to close off any pipelines, or open any valves, or take any other action which would affect the operation of the existing system, except as specifically required by the drawings and specifications, until authorization is granted by the CITY and after proper notification.
- D. Temporary installations required to complete a particular aspect of the work during the allotted time period shall be determined by the CONTRACTOR and implemented by the CONTRACTOR at no additional cost to the CITY. All such temporary installations shall be subject to the review and acceptance of the CITY.
- E. Sequence of certain major events and identification of time constraints for removing existing facilities from active service and installation of new facilities are described below. No phase of work (or tasks within a phase) shall preclude or be performed in parallel with a subsequent phase unless specifically defined so in these documents. In all cases, work in each phase shall be checked out and accepted for satisfactory use, subject to the CITY's approval, prior to the CONTRACTOR proceeding to the next phase of construction.



- F. Critical events in the sequence of construction are specified herein. The outlined sequence of construction does not include all items necessary to complete the Work, but is intended to identify the sequence of critical events necessary to eliminate disruption to the CITY's facilities. It shall be understood by the CONTRACTOR that the critical events identified are not all inclusive and that additional items of work not shown are required. The sequence of construction is a precedence requirement and does not attempt to schedule the CONTRACTOR's work.
- G. Wastewater Dewatering: The CONTRACTOR shall note that wastewater dewatering of existing pipelines and structures is required. The CONTRACTOR shall be responsible for the proper containment and disposal of wastewater, chemicals, etc. drained from existing pipelines and structures during construction. The CONTRACTOR shall contain such wastewater, chemicals, etc. in accordance with all applicable codes and shall dispose of such to an on-site wastewater basin as designated by the CITY. The CONTRACTOR shall be responsible for the prevention of wastewater, chemicals, etc. spills within the work area. Refer to Division 2 for additional requirements and related requirements for construction dewatering.
- H. Cancellation of Planned Shutdown: A planned shutdown in accordance with the Contract Documents may be canceled by the CITY upon 24 hour notification by the CITY to the CONTRACTOR. Cancellations shall be expected due to wet weather conditions or other conditions beyond control of the CITY or CONTRACTOR. All efforts shall be made by the CONTRACTOR to check weather forecasts and the like prior to scheduling shutdowns. The CITY shall not be responsible for any additional costs associated with the cancellation of a planned shutdown.
- I. Treatment Plant Access: CONTRACTOR shall maintain access for plant personnel to all treatment plant unit processes at all times. If demolition, construction, or rehabilitation activities impede or obstruct access to any unit process, CONTRACTOR shall provide a temporary means for access.

## 1.07 OVERALL SEQUENCE OF CONSTRUCTION

### A. Mobilization/Site Preparation:

1. Mobilize for work – Set up staging area as per Drawings, obtain any permits required, develop and submit construction schedule, submit shop drawing schedule and begin shop drawing submittals and procurement of materials.

### B. Demolition, Rehabilitation and Construction of Facilities:

1. CONTRACTOR shall complete all demolition, construction and rehabilitation work described in the Contract Documents.
2. CONTRACTOR shall complete all startup, testing and training activities required by the Contract Documents.
3. CONTRACTOR shall complete site restoration, site cleanup and demobilization activities.

C. Project Closeout:

1. CONTRACTOR shall complete all final punch list items.
2. CONTRACTOR shall complete project closeout in accordance with Section 01700.
3. Final acceptance of project.
4. Commence warranty period.

1.08 DETAILED SEQUENCE OF CONSTRUCTION AND OPERATIONAL CONSTRAINTS

A. Clarifier No. 3 Repair and Restoration of Operation

1. General Requirements:

- a. Clarifier No. 3 is currently out of service. The CONTRACTOR shall be responsible for draining and dewatering residual water and debris in the clarifier and pipelines, as required, to complete the work. The CONTRACTOR is responsible for disposal of the contents of the clarifier and pipelines.
- b. Contractor shall perform repair work on the sludge line per the Contract documents. It is anticipated that the Contractor will dismantle, remove, and relocate the clarifier mechanism, as necessary, to a City-designated location in order to perform the specified repair work.
- c. The CONTRACTOR shall re-install Clarifier No. 3 mechanism once repair work on the sludge line inside Clarifier No. 3 is complete and accepted by the CITY. The CONTRACTOR shall notify the ENGINEER and CITY upon re-installation, should clarifier mechanism parts require replacement. A period of two weeks shall be allocated for examination and issuance of a Field Order for clarifier mechanism replacement, if deemed necessary by the CITY (Refer to Paragraph 1.08(B), below).
- d. Upon completion of all work associated with Clarifier No. 3 repair and re-installation of equipment for a complete and operable system, the CONTRACTOR shall submit a Request for Services for the clarifier to be placed into service. The Clarifier shall operate successfully for a period of 30 consecutive days for final acceptance.
- e. CONTRACTOR shall complete site restoration, site cleanup and demobilization activities.

B. Clarifier No. 3 Mechanism Replacement (Alternate Bid Item)

- a. Upon issuance of written Field Order directing the Contractor to proceed with the work detailed in the Alternate Bid Item, Clarifier No. 3 shutdown shall be extended to no more than 480 days to perform all work for the project that requires the clarifier to be offline.

- b. Upon completion of all work associated with Clarifier No. 3 mechanism replacement, including static and dynamic torque testing per Section 11232, the CONTRACTOR shall submit a Request for Services for the clarifier to be placed into service. The Clarifier shall operate successfully for a period of 30 consecutive days for final acceptance.
- c. CONTRACTOR shall complete site restoration, site cleanup and demobilization activities including the disposal of the replaced clarifier mechanism and equipment.

1.09 WORK PLAN (Not Used)

PART 2 -- PRODUCTS (Not Used)

PART 3 – EXECUTION

3.01 COORDINATION WITH EXISTING UTILITIES AND OTHER AGENCIES

- A. The CONTRACTOR shall notify all utilities including but not limited to FPL, BellSouth, and Comcast Cable, as necessary, in writing with a copy to the CITY/ENGINEER prior to construction commencement. The CONTRACTOR shall cooperate with these utility owners as necessary to minimize service interruptions. The CONTRACTOR shall coordinate with Sunshine One-Call Notification at 1-800-432-4770 a minimum of 48 hours prior to any excavation for location of existing underground facilities.

3.02 COOPERATION

- A. The CONTRACTOR shall allow the CITY or its agents, and other project contractors or their agents, to enter facilities being constructed under this Contract for the purpose of constructing, installing, operating, maintaining, removing, repairing, altering or replacing such equipment pipes, sewers, conduits, manholes, wires, or other structures and appliances which may be required to be installed at or in the Work Area. The CONTRACTOR shall cooperate with all the aforesaid parties and shall allow reasonable provisions for the prosecution of any other work by the CITY, or others, to be done in connection with his work, or in connection with normal use of the facilities.

- END OF SECTION -

## SECTION 01530 - PROTECTION OF EXISTING FACILITIES

### PART 1 -- GENERAL

#### 1.01 THE REQUIREMENT

- A. The CONTRACTOR shall protect all existing utilities and improvements not designated for removal and shall restore damaged or temporarily relocated utilities and improvements to a condition equal to or better than they were prior to such damage or temporary relocation, all in accordance with requirements of the Contract Documents.
- B. The CONTRACTOR shall verify the exact locations and depths of all utilities shown and the CONTRACTOR shall make exploratory excavations of all utilities that may interfere with the Work. All such exploratory excavations shall be performed as soon as practicable after award of Contract and, in any event, a sufficient time in advance of construction to avoid possible delays to the CONTRACTOR'S Work. When such exploratory excavations show the utility location as shown to be in error, the CONTRACTOR shall so notify the CITY.
- C. The number of exploratory excavations required shall be that number which is sufficient to determine the alignment and grade of the utility.

#### 1.02 RIGHTS-OF-WAY

- A. The CONTRACTOR shall not enter upon any rights-of-way involved until notified that the CITY has secured authority therefore from the proper party. After authority has been obtained, the CONTRACTOR shall give said party due notice of its intention to begin Work, and shall give said party convenient access and opportunity for removing, shoring, supporting, or otherwise protecting utilities or structures within the right-of-way. When two or more contracts are being executed at one time on the same or adjacent land in such manner that Work on one contract may interfere with that on another, the CITY shall determine the sequence and order of the Work.

#### 1.03 PROTECTION OF STREET OR ROADWAY MARKERS

- A. The CONTRACTOR shall not destroy, remove, or otherwise disturb any existing survey markers or other existing street or roadway markers without proper authorization. No pavement breaking or excavation shall be started until all survey or other permanent marker points that will be disturbed by the construction operations have been properly referenced for easy and accurate restoration. It shall be the CONTRACTOR'S responsibility to notify the proper representatives of the CITY of the time and location that Work will be done. Such notification shall be sufficiently in advance of construction so that there will be no delay due to waiting for survey points to be satisfactorily referenced for restoration. All survey markers or points disturbed by the CONTRACTOR without proper authorization by the CITY, will be accurately restored by the CITY at the CONTRACTOR'S expense after all street or roadway resurfacing has been completed.

#### 1.04 RESTORATION OF FACILITIES

- A. General: All paved areas including asphaltic concrete berms cut or damaged during construction shall be replaced with similar materials and of equal thickness to match the existing adjacent undisturbed areas, except where specific resurfacing requirements have been called for in the Contract Documents or in the requirements of the agency issuing the permit. All temporary and permanent pavement shall conform to the requirements of the CITY. All pavements which are subject to partial removal shall be neatly saw cut in straight lines. All paved areas including asphaltic concrete berms cut or damaged during construction shall be replaced with similar materials and of equal thickness to match the existing adjacent undisturbed areas, except where specific restoration requirements have been called for in the Contract Documents or in the requirements of the agency issuing the permit.
- B. Temporary Restoration: Temporary restoration includes repair to all driveways, sidewalks and roadways. They shall be swept clean and be maintained free of dirt and dust. All areas disturbed by the construction activities shall be restored to proper grade, cleaned up, including the removal of debris, trash, and deleterious materials. All construction materials, supplies, or equipment, including piles of debris shall be removed from the area. All temporarily restored areas shall be maintained by the CONTRACTOR. These areas shall be kept clean and neat, free of dust and dirt, until final restoration operations are completed. The CONTRACTOR is responsible to utilize dust abatement operations in the temporarily restored areas as required, to the satisfaction of the ENGINEER.
- C. Temporary Resurfacing: Wherever required by the public authorities having jurisdiction, the CONTRACTOR shall place temporary surfacing promptly after backfilling and shall maintain such surfacing for the period of time fixed by said authorities before proceeding with the final restoration and improvements.
- D. Permanent Resurfacing: In order to obtain a satisfactory junction with adjacent surfaces, the CONTRACTOR shall saw cut back and trim the edge so as to provide a clean, sound, vertical joint before permanent replacement of an excavated or damaged portion of pavement. Damaged edges of pavement along excavations and elsewhere shall be trimmed back by saw cutting in straight lines. All pavement restoration and other facilities restoration shall be constructed to finish grades compatible with adjacent undisturbed pavement, unless otherwise shown on the drawings:
- E. Final Restoration: Final restoration shall include the completion of all required pavement replacement of roadways, driveways, curbs, gutters, sidewalks and other existing improvements disturbed by the construction: final grading, placement of sod, installation or replacement of any trees or shrubs, repair of irrigation systems, pavement marking, etc., all complete and finished, acceptable to the ENGINEER.

#### 1.05 EXISTING UTILITIES AND IMPROVEMENTS

- A. General: The CONTRACTOR shall protect all underground utilities and other improvements which may be impaired during construction operations. It shall be the CONTRACTOR'S responsibility to ascertain the actual location of all existing utilities and other improvements that will be encountered in its construction operations, and to

see that such utilities or other improvements are adequately protected from damage due to such operations.

- B. Where the proper completion of the Work requires the temporary or permanent removal and / or relocation of an existing utility or other improvement which is shown, the CONTRACTOR shall remove and temporarily replace or relocate such utility or improvement in a manner satisfactory to the CITY and the OWNER of the utility/facility. In all cases of such temporary removal or relocation, restoration to former location shall be accomplished by the CONTRACTOR in a manner that will restore or replace the utility or improvement as nearly as possible to its former locations and to as good or better condition than found prior to removal.
- C. CITY'S Right of Access: The right is reserved to the CITY and to the OWNER'S of public utilities and franchises to enter at any time upon any public street, alley, right-of-way, or easement for the purpose of making changes in their property made necessary by the Work of this Contract.
- D. Underground Utilities Shown or Indicated: Existing utility lines that are shown or the locations of which are made known to the CONTRACTOR prior to excavation and that are to be retained, and all utility lines that are constructed during excavation operations shall be protected from damage during excavation and backfilling and, if damaged, shall be immediately repaired by the CONTRACTOR.
- E. Underground Utilities Not Shown or Indicated: In the event that the CONTRACTOR damages any existing utility lines that are not shown or the locations of which are not made known to the CONTRACTOR prior to excavation, a written report thereof shall be made immediately to the CITY. If directed by the CITY, repairs shall be made by the CONTRACTOR under the provisions for changes and extra Work contained in the General Conditions.
- F. Approval of Repairs: All repairs to a damaged improvement are subject to inspection and approval by an authorized representative of the improvement and CITY before being concealed by backfill or other Work.
- G. No fill, excavation material, construction generated debris or equipment shall obstruct water valves, gas meters or sewer manholes. Water, sewer and gas service shall be made accessible to repair or maintenance crews representing the CITY or a privately-owned utility company.
- H. Maintaining in Service: All oil and gasoline pipelines, power, and telephone or other communication cable ducts, gas and water mains, irrigation lines, sewer lines, storm drain lines, poles, and overhead power and communication wires and cables encountered along the line of the Work shall remain continuously in service during all the operations under the Contract, unless other arrangements satisfactory to the CITY are made with the owner of said pipelines, duct, main, irrigation line, sewer, storm drain, pole, or wire or cable. The CONTRACTOR shall be responsible for and shall repair all damage due to its operations, and the provisions of this Section shall not be abated even in the event such damage occurs after backfilling or is not discovered until after completion of the backfilling.

PART 2 -- PRODUCTS (Not Used)

PART 3 -- EXECUTION (Not Used)

- END OF SECTION -

## SECTION 01550 - SITE ACCESS AND STORAGE

### PART 1 -- GENERAL

#### 1.01 SITE ACCESS

- A. The CONTRACTOR shall make its own investigation of the condition of available public and private roads and of clearances, restrictions, bridge load limits, and other limitations affecting transportation and ingress and egress to the site of the Work. It shall be the CONTRACTOR's responsibility to construct and maintain any haul roads required for its construction operations.
- B. The Southern Regional Wastewater Treatment Plant maintains a perimeter chain link fence and security gate. Delivery and employee access to the plant will be via the plant access electronic gate and security guard. Vehicles entering or leaving the plant will be required to check in with the security guard located at the gate.
- C. The CONTRACTOR will be responsible for monitoring the main gate for its personnel, equipment and material deliveries.

#### 1.02 STORAGE

- A. Limited storage area is available within the work areas shown on the Drawings. Any equipment and materials stored here shall be in accordance with the manufacturer's recommendations and as indicated by the CITY.
- B. Responsibility for protection and safekeeping of equipment and materials will be solely that of the CONTRACTOR, and no claim shall be made against the CITY by reason of any act of an employee or trespasser. Should an occasion arise necessitating access to an area occupied by stored equipment and/or materials, the CONTRACTOR shall immediately move them.
- C. If the CONTRACTOR requires additional staging and storage area than shown on the Drawings, the CONTRACTOR shall obtain such areas from off site sources at no additional cost to the CITY.
- D. Upon completion of the Contract, the CONTRACTOR shall remove from the storage and work areas all of their equipment, temporary fencing, surplus materials, rubbish, etc., and restore the area to its original or better conditions.

PART 2 -- PRODUCTS (Not Used)

PART 3 -- EXECUTION (Not Used)

- END OF SECTION -



## SECTION 01560 – TEMPORARY ENVIRONMENTAL CONTROLS

### PART 1 -- GENERAL

#### 1.01 CHEMICALS

- A. All chemicals used during project construction or furnished for testing of project operation, whether herbicide, pesticide, disinfectant, polymer, reactant of other classification, will be required to show approval of either EPA or HUD. The handling, use, storage and disposal of such materials, containers or residues shall be in strict conformance with manufacturer and/or CONTRACTOR'S secured storage. Copies of antidote literature and a supply of antidotes shall be kept at the job site office.

#### 1.02 DUST

- A. During all work for this Contract, the CONTRACTOR shall by the application of water and/or calcium chloride or other means, approved by the ENGINEER, eliminate dust annoyance to adjacent property, business establishments and the plant site as specified in Section 00700 - General Conditions. The CONTRACTOR shall take all protective measures, to the satisfaction of the ENGINEER, necessary to ensure that dust and debris does not enter any of the mechanical or electrical equipment. The CONTRACTOR shall be responsible for the cleanup of existing buildings, equipment, controls, etc., which have become soiled due to the lack of proper dust control as determined by the ENGINEER. The CONTRACTOR shall provide daily application of water to all unpaved areas designated by the ENGINEER in the field and to the satisfaction of the ENGINEER in the field.

#### 1.03 NOISE

- A. Noise resulting from the CONTRACTOR'S work shall not violate the Hollywood Code of Ordinance Chapter 100, with specific note to the restrictions of paragraph 100.05 or exceed the noise levels and other requirements stated in the Broward County Chapter 27 Pollution Control, relating to noise abatement in Broward County. The CONTRACTOR shall be responsible for curtailing noise resulting from his operation. He shall, upon written notification from the ENGINEER or the noise control officers, make any repairs, replacements, adjustments, additions and furnish mufflers when necessary to fulfill requirements.

#### 1.04 EROSION ABATEMENT AND WATER POLLUTION

- A. It is imperative that the CONTRACTOR'S dewatering operations not contaminate or disturb the plant environment or properties adjacent to the Work. The CONTRACTOR, shall, therefore, schedule and control his operations to confine all runoff water from disturbed surfaces, water from dewatering and/or from excavation below the ground water table operations that becomes contaminated with lime silt, muck and other deleterious matter, fuels, oils, bitumens, calcium chloride, chemicals and other polluting materials.

- B. The CONTRACTOR shall construct temporary stilling basin(s) of adequate size and provide all necessary temporary materials, operations and controls including, but not limited to, filters, coagulants, screens and other means necessary to attain the required discharge water quality.
- C. The CONTRACTOR shall be responsible for providing, operating and maintaining materials and equipment used for conveying the clear water to the point of discharge. All pollution prevention procedures, materials, equipment and related items shall be operated and maintained until such time as the dewatering operation is discontinued. Upon the removal of the materials, equipment and related items the CONTRACTOR shall restore the area to the condition prior to his commencing work.

1.05 HURRICANE AND STORM WARNINGS

- A. As the schedule for this project coincides, in part, with the recognized South Florida hurricane season, the CONTRACTOR’s attention is drawn to the possibility of hurricane conditions, or severe storm conditions, occurring at the job and plant site during the course of Contract work.
- B. Within 30-days of the date of Notice-to-Proceed, the CONTRACTOR shall submit to the ENGINEER and CITY a Hurricane Preparedness Plan. The plan should outline the necessary measures which the CONTRACTOR proposes to perform at no additional cost to the CITY in case of a hurricane warning.
- C. In the event of inclement weather, or whenever the ENGINEER shall direct, the CONTRACTOR shall, and will cause Sub-Contractors to protect carefully the Work and materials against damage or injury by reasons of failure on the part of the CONTRACTOR to so protect the Work. Such Work and materials so damaged shall be removed and replaced at the expense of the CONTRACTOR.
  - 1. Hurricane Watch: Upon designation of a hurricane watch, CONTRACTORS shall be responsible for storing all loose supplies and equipment on the job site that may pose a danger. The CONTRACTOR shall backfill all open holes in preparation of inclement weather. In addition, the CONTRACTOR shall remove all bulkheads and plugs in pipelines that would impede drainage in the case of flooding. Structures that may be in danger of floatation shall be flooded. The CONTRACTOR shall also cooperate with CITY personnel in protecting other structures at the site.
  - 2. Hurricane Warning: No mobile “temporary facility” under the control of the City of Hollywood, or on City property, shall be staffed during a hurricane warning. CONTRACTOR facilities meeting these criteria shall comply.
- D. The CONTRACTOR is advised to take all necessary precautions to protect his equipment by moving it to higher ground if in an area subject to flooding. Known areas of Hollywood that would be subject to flooding from storm tides include:

Hollywood Blvd.	North Lake Area	South Lake Area
A1A	Sheridan Street	Dania Beach Blvd.
US Highway 1	46 <sup>th</sup> Avenue	Hallandale Beach Blvd.

## 1.06 PESTS AND RODENTS

- A. The CONTRACTOR shall be responsible for maintaining the jobsite free from litter, rubbish and garbage. He shall provide containers for the disposal of garbage and other materials that attract and are breeding places for pests and rodents. The CONTRACTOR shall provide the services of an exterminator to inspect the jobsite on a periodic basis and to provide service as required to control pests and rodents.

## 1.07 PERIODIC CLEAN-UP; BASIC SITE RESTORATION

- A. During construction, the CONTRACTOR shall regularly remove from the site all accumulated debris and surplus materials of any kind which result from his operations, or whenever the accumulation is in excess of one truck load. Unused equipment and tools shall be stored at the CONTRACTOR'S yard or base of operations for the project.
- B. When the work involves installation of sewers, drains, water mains, manholes, underground structures, or other disturbance of existing features in or across streets, rights-of-way, easements, or private property, the CONTRACTOR shall (as the work progresses) promptly backfill, compact, grade and otherwise restore the disturbed area to a basic condition which will permit resumption of pedestrian or vehicular traffic and any other critical activity or function consistent with the original use of the land. Unsightly mounds of earth, large stones, boulders, and debris shall be removed so that the site presents a neat appearance.
- C. The CONTRACTOR shall perform the clean-up work on a regular basis and as frequently as ordered by the ENGINEER. Basic site restoration in a particular area shall be accomplished immediately following the installation or completion of the required facilities in that area. Furthermore, such work shall also be accomplished, when ordered by the ENGINEER, if partially completed facilities must remain incomplete for some time period due to unforeseen circumstances.
- D. Upon failure of the CONTRACTOR to perform periodic clean-up and basic restoration of the site to the ENGINEER'S satisfaction, the ENGINEER may, upon five (5) days prior written notice to the CONTRACTOR, employ such labor and equipment as he deems necessary for the purpose, and all costs resulting therefrom shall be charged to the CONTRACTOR and deducted from the amounts of money that may be due him.

## 1.08 SECURITY

- A. The CONTRACTOR shall care for and protect against loss or damage of all material to be incorporated in the construction for the duration of the Contract and shall repair or replace damaged or lost materials and damage to structures.
- B. The CONTRACTOR shall be responsible for providing, and maintaining temporary fencing and gates and the daily securing of temporary fencing and gates used for construction purposes for the duration of the project.
- C. The CONTRACTOR shall strictly comply with working hours on the project site. Prior to any work outside of the standard working hours, the CONTRACTOR shall request the CITY's approval via written request (at least 8 hours in advance). The written request shall clearly define the work to be performed, the names of the employees, their

employer and their trade and the hours and days during which the work is planned. The CITY is considering and the CONTRACTOR shall comply with additional security requirements including employee photo identification at all times on-site and employee parking passes.

1.09 CHLORINE EMERGENCY PREPARATION

- A. The CONTRACTOR's attention is directed to the CITY's policy of conducting periodic chlorine emergency drills at the WWTP. The drills are intended to ensure readiness to respond to a potential emergency due to the leakage of chlorine gas (which is a toxic substance) from the Chlorine Facility at the WWTP. The CONTRACTOR shall designate an on-site member of his staff that will be trained by the CITY and be responsible for ensuring that the CONTRACTOR's and subcontractor's personnel fully participate in the drills and are prepared to deal with a potential emergency. The CONTRACTOR shall submit for each WWTP operation shift change (before 9:00 A.M., 5:00 P.M., 1:00 A.M.) a list of names of these employees and all subcontractor's employees working on the project site during construction of the interceptor structure.

PART 2 -- PRODUCTS (Not Used)

PART 3 -- EXECUTION (Not Used)

- END OF SECTION -

## SECTION 01590 – FIELD OFFICE, EQUIPMENT AND SERVICES

### PART 1 -- GENERAL

#### 1.01 THE REQUIREMENT

- A. The CONTRACTOR is not required to provide a field office. Should the CONTRACTOR elect to provide a field office, the CONTRACTOR is responsible for providing a suitable location for the field office. The CITY will not provide an area for a field office for the work.
- B. If field offices are to be furnished and installed, the CONTRACTOR shall be responsible for providing temporary utilities including power, lighting, heating, cooling, and ventilating, water, sanitary and personnel facilities, telephone service, and fire protection as required.
- C. The CONTRACTOR shall be responsible for providing sufficient area for employee parking at the field office. The CITY will not provide parking area for CONTRACTOR's employee parking.
- D. If applicable, the CONTRACTOR shall prepare and submit all required drawings with sufficient detail as necessary to the City of Hollywood Building Department for permitting of the field office and utility hookups. The CONTRACTOR shall comply with all Building Department requirements accordingly.

### PART 2 -- PRODUCTS (Not Used)

### PART 3 -- EXECUTION (Not Used)

- END OF SECTION -

## SECTION 01600 – EQUIPMENT AND MATERIALS

### PART 1 -- GENERAL

#### 1.01 THE REQUIREMENT

- A. The word "Products," as used herein is defined to include purchased items for incorporation into the Work, regardless of whether specifically purchased for project or taken from CONTRACTOR's stock of previously purchased products. The word "Materials," is defined as products which must be substantially cut, shaped, worked, mixed, finished, refined, or otherwise fabricated, processed, installed, or applied to form units of Work. The word "Equipment" is defined as products with operational parts, regardless of whether motorized or manually operated, and particularly including products with service connections (wiring, piping, and other like items). Definitions in this paragraph are not intended to negate the meaning of other terms used in Contract Documents, including "specialties," "systems," "structure," "finishes," "accessories," "furnishings," "special construction," and similar terms, which are self-explanatory and have recognized meanings in the construction industry.
- B. Equipment Specifications may not deal individually with minute items required such as components, parts, controls, and devices which may be required to produce the equipment performance specified or as required to meet the equipment warranties. Where such items are required, they shall be included by the supplier of the equipment, whether or not specifically called for in the Contract Documents.
- C. All equipment, materials, instruments or devices incorporated in this project shall be new and unused, unless indicated otherwise in the Contract Documents. Equipment and materials to be incorporated into the work shall be delivered sufficiently in advance of their installation and use to prevent delay in the execution of the work, and they shall be delivered as nearly as feasible in the order required for executing the work.
- D. Where the words "furnish", "provide", "supply", "replace", or "install" are used, whether singularly or in combination, they shall mean to furnish and install, unless specifically stated otherwise.
- E. In the interest of brevity, the explicit direction "to furnish and install" has sometimes been omitted in specifying materials and/or equipment herein. Unless specifically noted otherwise, it shall be understood that all equipment and/or materials specified or shown on the Drawings shall be furnished and installed under the Contract as designated on the Drawings.

#### 1.02 INSTALLATION OF EQUIPMENT

- A. Equipment and materials shall be installed in accordance with the requirements of the General Conditions, Supplemental Conditions and the respective Specification Sections.
- B. Concrete foundations for equipment shall be of approved design and shall be adequate in size, suitable for the equipment erected thereon, properly reinforced, and tied into floor slabs by means of reinforcing bars or dowels. Foundation bolts of ample size and strength shall be provided and properly positioned by means of suitable templates and secured

during placement of concrete. Foundations shall be built and bolts installed in accordance with the manufacturer's certified drawings.

- C. Before mounting equipment on a foundation, the CONTRACTOR shall clean the top surface; if necessary, rough it with a star chisel and clean again; and clean out all foundation bolt sleeves. The CONTRACTOR shall provide a sufficient number of stainless steel plate shims about 2-inches wide and 4-inches long, and of a varying thickness from 1/8 to 1/2 inch. A combination of these shims shall be placed next to each foundation bolt to bring the bottom of the bedplate or frame about 1/8 inch above the final setting. The equipment shall be lowered by changing the combination of shims. Using stainless steel shim stock of various thicknesses, continue to level the equipment a little at a time and in rotation until it is at the correct elevation in both directions. When the equipment is level, tighten down on the foundation bolts a little at a time in rotation to make certain the equipment remains level and does not shift on the shims. A preliminary alignment check shall be made before grout is placed.
- D. Equipment shall be set, aligned and assembled in conformance with manufacturer's drawings or instructions. Run out tolerances by dial indicator method of alignment shall be plus or minus .002 inches, unless otherwise directed by the CITY.
- E. All blocking and wedging required for the proper support and leveling of equipment during installation shall be furnished by the CONTRACTOR. All temporary supports shall be removed, except stainless steel wedges and shims, which may be left in place with the approval of the CITY.
- F. Each piece of equipment or supporting base, bearing on concrete foundations, shall be bedded in grout. The CONTRACTOR shall provide a minimum of 1-1/2-inch thick grouting under the entire baseplate supporting each pump, motor drive unit and other equipment. Grout shall be non-shrink grout, as specified under Section 03315 entitled "Grout".
- G. When motors are shipped separately from driven equipment, the motors shall be received, stored, meggered once a month, and the reports submitted to the CITY. After driven equipment is set, the motors shall be set, mounted, shimmed, millrighted, coupled and connected complete. Motors shall then be turned once per month and documented by the CONTRACTOR to the CITY.

### 1.03 CONNECTIONS TO EQUIPMENT

- A. Connections to equipment shall follow manufacturer's recommendations as to size and arrangement of connections and/or as shown in detail on the Drawings or approved Shop Drawings. Piping connections shall be made to permit ready disconnection of equipment with minimum disturbance of adjoining piping and equipment.
- B. The Electrical CONTRACTOR or CONTRACTOR if no electrical contract exists shall be responsible for bringing proper electrical service to each item of equipment requiring electrical service as shown on the Drawings or approved Shop Drawings. Electrical connections to equipment requiring electrical service shall be made by the Electrical CONTRACTOR, unless otherwise indicated on the Drawings or in the Technical Specifications.

- C. The HVAC CONTRACTOR or CONTRACTOR if no HVAC Contract exists shall bring and connect HVAC service to all equipment items requiring same as shown on the Drawings. Electrical connections to equipment requiring electrical service shall be made by the Electrical CONTRACTOR, unless otherwise indicated on the Drawings or in the Technical Specifications.
- D. The Plumbing CONTRACTOR or CONTRACTOR if no plumbing contract exists shall bring and connect plumbing service to all equipment items requiring same as shown on the Drawings.

#### 1.04 IDENTIFICATION TAGS FOR EQUIPMENT AND INSTRUMENTS

- A. All process equipment, pumps, blowers, valves, gates and process instruments that are identified by a tag number on the Process and Instrumentation Diagrams (P&IDs on Instrumentation contract drawings) shall have an identification tag at the device.
- B. The identification tag shall show a unique tag number for the device (e.g., CFP-6010), and the common name of the device (e.g., Centrifuge Feed Pump No. 1).
- C. The identification tag shall be either lamacoid tag with white background and black core letters, or non-corrosive metal tags, ASTM A240 Grade 430 stainless steel with a bright annealed finish.
- D. Characters on identification tags shall be 3/16" high and surface cut deep unless otherwise noted. Characters shall be cut into the lamacoid tags with a hardened steel router bit and into stainless steel tags with a diamond tip cutter.
- E. Identification tags shall be buffed around the perimeter to remove any sharp edges or corners.
- F. Identification tags shall be attached to the equipment item, valve, or instrument with 0.9 mm diameter wire or stainless steel screws.

#### 1.05 PRODUCT DELIVERY-STORAGE-HANDLING

- A. The CONTRACTOR shall deliver, handle, and store products in accordance with supplier's written recommendations and by methods and means which will prevent damage, deterioration, and loss including theft. Delivery schedules shall be controlled to minimize long-term storage of products at site and overcrowding of construction spaces. In particular, the CONTRACTOR shall provide delivery/installation coordination to ensure minimum holding or storage times for products recognized to be flammable, hazardous, easily damaged, or sensitive to deterioration, theft, and other sources of loss. Any equipment or materials of whatever kind which may have become damaged or deteriorated from any cause shall be removed and replaced by good and satisfactory items at the CONTRACTOR's expense for both labor and materials.

#### 1.06 TRANSPORTATION AND HANDLING

- A. Products shall be transported by methods to avoid product damage and shall be delivered in undamaged condition in supplier's unopened containers or packaging, dry.



- B. The CONTRACTOR shall provide equipment and personnel to handle products, materials, and equipment including those provided by CITY, by methods to prevent soiling and damage.
- C. The CONTRACTOR shall provide additional protection during handling to prevent marring and otherwise damaging products, packaging, and surrounding surfaces.

#### 1.07 STORAGE AND PROTECTION

- A. The CONTRACTOR shall protect all equipment and materials from deterioration and damage, including provisions for temporary storage buildings as needed and as specified in Section 01550 entitled "Site Access and Storage".
- B. Products shall be stored in accordance with supplier's written instructions, with seals and labels intact and legible. Sensitive products shall be stored in weather-tight enclosures and temperature and humidity ranges shall be maintained within tolerances required by supplier's written instructions.
- C. Storage of equipment and materials shall be in locations completely protected from flooding, standing water, excessive dust, falling rock, brush fire, etc. Storage areas shall be located sufficiently distant from all construction activities and the movement of construction vehicles to minimize the potential for accidental damage.
- D. For exterior storage of fabricated products, they shall be placed on sloped supports above ground. Products subject to deterioration shall be covered with impervious sheet covering; ventilation shall be provided to avoid condensation.
- E. Loose granular materials shall be stored on solid surfaces in a well drained area and shall be prevented from mixing with foreign matter.
- F. Storage shall be arranged to provide access for inspection. The CONTRACTOR shall periodically inspect to assure products are undamaged and are maintained under required conditions.
- G. Storage shall be arranged in a manner to provide access for maintenance of stored items and for inspection.

#### 1.08 MAINTENANCE OF STORAGE

- A. Stored products shall be periodically inspected on a scheduled basis. The CONTRACTOR shall maintain a log of inspections and shall make said log available to the ENGINEER on request.
- B. The CONTRACTOR shall verify that storage facilities comply with supplier's product storage requirements.
- C. The CONTRACTOR shall verify that supplier-required environmental conditions are maintained continually.

- D. The CONTRACTOR shall verify that surfaces of products exposed to the elements are not adversely affected and that any weathering of finishes is acceptable under requirements of Contract Documents.

#### 1.09 MAINTENANCE OF EQUIPMENT STORAGE

- A. For mechanical and electrical equipment in long-term storage, the CONTRACTOR shall provide a copy of the supplier's service instructions to accompany each item, with notice on enclosed instruction shown on exterior of package.
- B. Equipment shall be serviced on a regularly scheduled basis, and a log of services shall be maintained and submitted as a record document to the ENGINEER.

#### 1.10 LUBRICANTS

- A. During testing and prior to acceptance, the CONTRACTOR shall furnish all lubricants necessary for the proper lubrication of all equipment furnished under this Contract.

#### 1.11 SPECIAL TOOLS

- A. For each type of equipment furnished by him, the CONTRACTOR shall provide a complete set of all special tools (including calibration and test equipment) which may be necessary for the adjustment, operation, maintenance and disassembly of such equipment.
- B. Special tools shall be delivered at the same time as the equipment to which they pertain. The CONTRACTOR shall properly store and safeguard such special tools until completion of the Work, at which time they shall be delivered to the CITY.

#### 1.12 PROTECTION AGAINST ELECTROLYSIS

- A. Where dissimilar metals are used in conjunction with each other, suitable insulation shall be provided between adjoining surfaces so as to eliminate direct contact and any resultant electrolysis. The insulation shall be bituminous impregnated felt, heavy bituminous coatings, nonmetallic separators or washers, or other acceptable materials.

#### 1.13 FASTENERS

- A. All necessary bolts, anchor bolts, nuts, washers, plates and bolt sleeves shall be furnished by the CONTRACTOR in accordance herewith. Bolts shall have suitable washers and, where so required, their nuts shall be hexagonal.
- B. All bolts, anchor bolts, nuts, washers, plates, and bolt sleeves shall be Type 316 stainless steel unless otherwise specifically indicated or specified.
- C. Unless otherwise specified, stud, tap, and machine bolts shall be of the best quality refined bar iron. Hexagonal nuts of the same quality of metal as the bolts shall be used.

#### 1.14 EXCAVATED MATERIALS

- A. All excavated materials needed for backfilling operation shall be stored on site. Where additional area is needed for stockpiling, it shall be obtained by the CONTRACTOR.

B. Any excess backfill shall be delivered to the CITY's property as directed by the ENGINEER.

PART 2 -- PRODUCTS

(NOT USED)

PART 3 -- EXECUTION

(NOT USED)

- END OF SECTION -

## SECTION 01650 - EQUIPMENT TESTING AND STARTUP

### PART 1 -- GENERAL

#### 1.01 GENERAL

- A. Equipment testing and startup are requisite to satisfactory completion of the contract and, therefore, shall be completed within the Contract time.
- B. As construction of the project enters the final stages of completion, the CONTRACTOR shall, in accordance with the requirements set forth in the Contract Documents, attend to the following items:
  - 1. Complete all punch list items required by the ENGINEER prior to startup-up.
  - 2. Schedule equipment manufacturer's visits to site.
  - 3. Calibration of instruments and controls.
  - 4. Perform required testing, adjusting and balancing of project components.
  - 5. Complete all punch list items that result from testing.
  - 6. Schedule and coordinate training and testing activities.
  - 7. Furnish skilled personnel from manufacturer's and suppliers during training and testing activities.
  - 8. Furnish operation and maintenance training for CITY's personnel.
  - 9. Successfully demonstrate reliable operation of project systems.
- C. Additional requirements for testing of the pumps are defined in Division 11.

#### 1.02 DEFINITIONS

- A. Facility Startup: Includes putting Project in operating order, cleaning, adjusting and balancing equipment, initial operation (startup) of equipment item, operating equipment, starting systems, operation of systems, testing of equipment and systems, completing required punch list items, and demonstration and verification of the completed facility as a unit.
- B. Functional Testing: A test or tests in the presence of the ENGINEER and/or CITY to demonstrate that the installed equipment or system meets manufacturer's installation and adjustment requirements and other requirements specified including, but not limited to, noise, vibration, alignment, speed, proper operation of electrical, mechanical and information and control equipment, thrust restraint, proper rotation, and initial servicing.
- C. System Performance Testing: A test performed in the presence of the ENGINEER and/or CITY after satisfactory completion of required functional testing, to demonstrate and confirm that the equipment and/or system meet the specified performance requirements for

a specified minimum operation period without significant interruption. System performance testing shall not begin until the following are completed:

1. The CONTRACTOR has submitted written test reports, installation reports, and performance affidavits as required in the Contract Documents.
  2. The CONTRACTOR has completed all punch list items.
  3. The CONTRACTOR has completed all functional testing.
- D. Operation Period: The operation period for Performance Testing shall be as defined in the Supplementary General Conditions without significant interruption.
- E. Significant Interruption: May include any of the following events:
1. Failure of CONTRACTOR to maintain qualified onsite startup personnel as scheduled.
  2. Failure to meet specified performance for more than two consecutive hours.
  3. Failure of any critical equipment unit, system, or subsystem that is not satisfactorily corrected within five hours after failure.
  4. Failure of noncritical unit, system, or subsystem that is not satisfactorily corrected within eight hours after failure.
  5. As may be determined by ENGINEER.
- F. System: The overall process, or a portion thereof, that performs a specific function. A system may consist of two or more subsystems as well as two or more types of equipment. The "System" shall be as determined by the ENGINEER.
- G. Training: The services provided by the CONTRACTOR and his equipment suppliers to ensure that the CITY's staff is completely prepared to operate and maintain the contract facilities. Training shall include classroom instruction, as well as "hands-on" field/equipment demonstration, operation and maintenance. Equipment/contract fabrication shall be 100 percent operational (as defined by the ENGINEER) during training activities.

#### 1.03 CONTRACTOR'S RESPONSIBILITIES

- A. The CONTRACTOR shall designate and furnish one or more persons to be responsible for coordinating and expediting CONTRACTOR's facility startup, testing and training duties. The person or persons shall be present during Facility Startup, Functional Testing, and Training meetings and shall be available at all times during the Facility Startup and Training period. In addition, the person or persons shall be "on call" (available to assist the CITY) at all times during the System Performance Testing.
- B. The CONTRACTOR shall provide the services of an experienced and authorized representative of the supplier of each item of equipment (excluding minor items of equipment specifically exempted by the ENGINEER in writing), who shall visit the site of the Work and inspect, check, adjust if necessary, and approve the equipment installation. In each case, the CONTRACTOR shall arrange to have the supplier's representative revisit

the job site as often as necessary until any and all trouble is corrected and the equipment installation and operation are satisfactory to the ENGINEER.

- C. The CONTRACTOR shall require that each supplier's representative furnish to the ENGINEER a written report addressed to the CITY, and copied to the ENGINEER, certifying that the equipment has been properly installed and lubricated, is in accurate alignment, is free from any undue stress imposed by connecting piping or anchor bolts, has been operated satisfactorily under the complete range of, including but not limited to full-load, conditions, is ready for operation and the CITY's operating personnel have been instructed in the operation, maintenance and lubrication of the equipment.
- D. The CONTRACTOR shall furnish all personnel, power, water, chemicals, fuel, oil, grease, and all other necessary equipment, facilities, and services required for conducting the tests.
- E. The CONTRACTOR shall coordinate startup, testing and training activities with CITY/ENGINEER in advance and in writing.

#### 1.04 SUBMITTALS

- A. Test Schedules and Plan: 8 copies of functional and system performance test schedules and plans for equipment, units, and systems shall be submitted to the ENGINEER, in accordance with the Section entitled "Submittals" at least 3 months prior to start of related testing. The test plan shall contain the following at a minimum:
  - 1. A schedule of all testing to be conducted.
  - 2. A brief description of the testing to be performed.
  - 3. Testing criteria.
  - 4. Checklists and procedures for performing each test.
  - 5. Sample forms for the collection of test data.
  - 6. Sample test results documentation.
  - 7. Requirements for other parties.
- B. Test Reports and Certificates of Compliance: Functional and performance testing reports, and certificates of compliance, in a format acceptable to the ENGINEER, shall be furnished in accordance with the Section entitled "Submittals". Test reports and certificates of compliance shall be submitted prior to project closeout in accordance with the requirements of the Section entitled "Project Closeout".
- C. Training Schedules and Plan: 8 copies of written training schedule and written training plan shall be submitted to the ENGINEER, in accordance with the Section entitled "Submittals" at least 30 days prior to start of related operation and maintenance training. The training plan shall contain the following at a minimum:
  - 1. A schedule of all training to be conducted. The training schedule shall be adjusted as deemed necessary by the CITY, to allow full participation by the supplier's

representative, CITY's personnel and as needed if the operability of the system being trained on is interrupted for any reason. This may require training during three separate shifts.

2. A brief description of the training to be performed.
3. Sample training materials and handouts.
4. Qualifications of the supplier's representative performing the training.
5. Training agenda shall be prepared and submitted to the ENGINEER at least 2 weeks in advance for approval. Rejection of the training agenda may delay the training, at the CITY's option. As a minimum, the agenda shall include but not limit to the following items:
  - General description of the equipment item
  - Start-up procedure
  - Shutdown procedure
  - Operation and control description
  - Adjustment and trouble-shooting
  - Maintenance

The CONTRACTOR shall provide professional audio-video recording (MP4 format) of all training sessions (as selected by the CITY). Two labeled USB flash drives of each training session shall be furnished to the CITY within two weeks of completion of the training.

- D. Written Notification: Any CONTRACTOR activity that may impact operation of existing facilities shall be confirmed in writing at least 48 hours in advance of initiation of that activity. This requirement is in addition to the 30-day advance submittal of plans to more closely confirm coordination efforts required. This notification shall include, as a minimum:
- Scheduled date and time (start, finish, duration) of CONTRACTOR's activity
  - Brief description of activity
  - Brief description of any CITY activity that is required to coordinate with CONTRACTOR's activity (such as shutdown of a unit process or system, power supply, etc.).

#### 1.05 TOOLS

- A. Any special tools which may be necessary for the adjustment, operation, and maintenance of any equipment shall be furnished with the respective equipment. The CONTRACTOR shall furnish a complete list of tools and instructions for their use, recommended by the manufacturer or CONTRACTOR with the Shop Drawing submittal.

#### 1.06 SPARE PARTS

- A. Spare parts for equipment shall be furnished where indicated in the equipment specifications and/or recommended by the equipment manufacturer. Spare parts shall be

identical and interchangeable with original parts. Parts shall be supplied, prepared for storage, in clearly identified containers. Large or bulky items shall also be prepared for storage, clearly identified and wrapped in polyethylene or other suitable protection.

- B. The parts shall be stored separately in a locked area, maintained by the CONTRACTOR, and shall be delivered to the CITY as a complete package for each equipment item at a location designated by the CITY. The CONTRACTOR shall furnish an inventory listing all spare parts for each piece of equipment utilizing the form included at the end of this Section.

## PART 2 -- PRODUCTS (Not Used)

## PART 3 -- EXECUTION

### 3.01 PREPARATION FOR EQUIPMENT FUNCTIONAL TESTING

- A. Conduct (or have previously conducted, whichever is appropriate) all field inspections and tests as defined in the individual specification sections, installation checks, disinfection, hydrostatic tests, other preliminary or initial tests, and necessary corrections required, to demonstrate that individual components of the Work have been properly erected and found to operate in accordance with the Contract Documents, so that they can be utilized for their intended purposes.
- B. Remove all electrical jumpers, bypasses or other items connected to the equipment which are not intended to remain in the facility and are not required by the specifications. Demonstrate that each component is operating under its own control as designated.
- C. Confirm that all electrical circuits are energized in the automatic position, that valves and gates are set to their normal position and that the flow path through the Work is unobstructed.
- D. Equipment and electrical tagging shall be complete prior to initiation of function testing.
- E. All spare parts and special tools shall be delivered to CITY prior to initiation of function testing.
- F. Provide written supplier's certifications of installation confirming readiness for functional testing.

### 3.02 FUNCTIONAL TESTING

- A. General:
  - 1. Begin testing at a time mutually agreed upon by the CITY and/or ENGINEER, manufacturer's representative(s), and CONTRACTOR.
  - 2. Notify in writing CITY, ENGINEER, and manufacturer's representative at least 14 days prior to scheduled date of functional tests.



3. Separate items of equipment demonstrated to function properly during subsystem testing may require no further functional test if documentation of subsystem testing is acceptable to ENGINEER.
4. Conduct functional test until each individual component item or system has achieved 2 continuous hours of satisfactory operation. Demonstrate all operational features and controls function during this period while in automatic modes.
5. If, in ENGINEER's opinion, each system meets the functional requirements specified, such system will be accepted as conforming for purposes of advancing to performance testing phase, if required. If, in ENGINEER's opinion, functional test results do not meet requirements specified, the systems will be considered as nonconforming.

### 3.03 SYSTEM PERFORMANCE TESTING

#### A. General:

1. The startup of each facility and performance testing is a highly complex operation requiring the combined technical expertise of the CONTRACTOR, suppliers, subcontractors, the ENGINEER, and the CITY. The CONTRACTOR shall provide the effective and advance coordination of all parties necessary for the successful startup.
2. System performance testing shall not commence until punch list items are adequately addressed to the ENGINEER's satisfaction, and the equipment or system meets functional tests specified.
3. All defects in materials or workmanship that appear during the system performance test shall be immediately corrected by the CONTRACTOR. Time lost for equipment repairs, wiring corrections, control point settings, or other reasons which actually interrupt the startup may, at the discretion of the ENGINEER, be justifiable cause for extending the system performance test Operation Period.
4. Should a significant interruption as defined previously in this Section, be incurred, the test shall be restarted from the beginning, unless the failure is of two hours or less in duration, or considered minor by the ENGINEER. The CONTRACTOR shall bear all costs associated with restarting the test period. Restart of the test period shall be solely at the ENGINEER's discretion.

#### B. System Performance Testing:

1. The duration of the system performance test shall be as defined in Article 1.02 of this Section, or as defined elsewhere in the Documents, whichever is longer.
2. The CONTRACTOR shall provide technical representatives of all equipment manufacturers, system suppliers, subcontractors, etc., for as-needed service to address mechanical malfunctions.
3. The CONTRACTOR shall furnish and coordinate the services of technical representatives of all equipment manufacturers to perform the testing services outlined in Contract Documents and the testing plan. The technical representatives

of all equipment manufacturers shall perform startup testing and prepare test reports.

4. During the System Performance Testing, the CONTRACTOR shall assist the CITY in directing the CITY's personnel performing routine operating functions for the new facility.
5. The CONTRACTOR shall also be responsible for furnishing mechanics, labor, materials, and equipment that may be required to repair any malfunctions to equipment furnished and installed under the scope of this project.

#### 3.04 O&M TRAINING

- A. The training period shall not begin until successful completion of all system Functional Testing. The training period may be concurrent with the System Performance Testing period, however, shall not be deemed complete or shall be considered interrupted if there is a significant interruption of the System Performance Testing. If a significant interruption occurs, training shall be repeated and/or continued, at the CITY's option, at the time that the Performance Testing restarts. Also, training shall not begin until all O&M Manuals, specified in the Section entitled "Submittals", have been accepted by the ENGINEER.
- B. During the training period the CONTRACTOR shall provide the services of an experienced representative of the supplier of each item of equipment (excluding minor items of equipment specifically exempted by the ENGINEER in writing), who shall visit the site and instruct the CITY's operating and maintenance personnel in correct operation and maintenance procedures. It is noted that training requirements are specified throughout the Contract Documents. The instruction shall demonstrate start-up, operation, control, adjustment, trouble-shooting, servicing, maintenance, and shutdown of each item of equipment. Training shall include classroom and field/hands-on (with operational equipment) instructions. Training shall be provided only while the respective representative's equipment is fully operational. On-site instruction shall be given by qualified persons who have been made familiar in advance with the equipment and systems at the project site.
- C. Training shall be scheduled and coordinated by the CONTRACTOR. Training hours shall be arranged in writing with the CITY at least 14 days in advance of the scheduled training with a subsequent written confirmation at least 48 hours in advance.

## SPARE PARTS INVENTORY

### SUMMARY SHEET

EQUIPMENT NO. \_\_\_\_\_ DATE \_\_\_\_\_

LOCATION \_\_\_\_\_ REV. \_\_\_\_\_

NAME \_\_\_\_\_

ADDRESS \_\_\_\_\_

\_\_\_\_\_ PHONE ( ) \_\_\_\_\_

SPARE PARTS INVENTORY:

_____	_____
_____	_____
_____	_____
_____	_____
_____	_____
_____	_____
_____	_____
_____	_____
_____	_____
_____	_____
_____	_____
_____	_____
_____	_____
_____	_____
_____	_____
_____	_____
_____	_____
_____	_____
_____	_____
_____	_____
_____	_____

- END OF SECTION -

## SECTION 01700 - PROJECT CLOSEOUT

### PART 1 -- GENERAL

#### 1.01 PROJECT CLOSEOUT

- A. As construction of the project enters the final stages of completion, the CONTRACTOR shall, in accordance with the requirements set forth in the Contract Documents, attend to or have already completed the following items:
1. Scheduling start-up and initial operation.
  2. Correcting or replacing defective work, including completion of items previously overlooked or work which remains incomplete, all as evidenced by the CITY's "Punch" lists.
  3. Make final submittals.
  4. Attend to any other items listed herein or brought to the CONTRACTOR's attention by the CITY.

#### 1.02 CLOSEOUT TIMETABLE

- A. The CONTRACTOR shall establish dates for equipment testing, acceptance periods, and instructional periods (as required under the Contract). Such dates shall be established not less than one week prior to beginning any of the foregoing items, to allow the CITY, the ENGINEER and their authorized representatives sufficient time to schedule attendance at such activities.

#### 1.03 FINAL SUBMITTALS

- A. Before the acceptance of the project major milestones for substantial completion, the CONTRACTOR shall submit to the ENGINEER (or to the CITY if indicated) certain records, certifications, etc., which are specified elsewhere in the Contract Documents. Missing, incomplete or unacceptable items, as determined by the ENGINEER, shall indicate non-compliance with substantial completion major milestone dates. A partial list of such items appears below, but it shall be the CONTRACTOR'S responsibility to submit any other items which are required in the Contract Documents:
1. Written Test results of project components.
  2. Performance affidavits for equipment.
  3. Operation and Maintenance Manuals for equipment.
  4. Record Drawings: During the entire construction operation, the CONTRACTOR shall maintain records of all deviations from the Drawings and Specifications and shall prepare record drawings showing correctly and accurately all changes and deviations from the Work made during construction to reflect the Work as it was actually constructed. These drawings shall conform to recognized standards of

drafting, shall be neat, legible and on mylar or other reproducible material acceptable to the ENGINEER.

5. Written guarantees, where required.
6. Certificates of inspection and acceptance by local governing agencies having jurisdiction.
7. Releases from all parties who are entitled to claims against the subject project, property, or improvement pursuant to the provisions of law.

#### 1.04 PUNCH LISTS

- A. Final cleaning and repairing shall be scheduled upon completion of the project.
- B. The ENGINEER will make his final inspection whenever the CONTRACTOR has notified the ENGINEER that the work is ready for the inspection. Any work not found acceptable and requiring cleaning, repair and/or replacement will be noted on the "Punch" list. Work that has been inspected and accepted by the ENGINEER shall be maintained by the CONTRACTOR, until final acceptance of the entire project.
- C. Whenever the CONTRACTOR has completed the items on the punch list, he shall again notify the ENGINEER that it is ready for final inspection. This procedure will continue until the entire project is accepted by the ENGINEER. The "Final Payment" will not be processed until the entire project has been accepted by the ENGINEER and all of the requirements in previous Article 1.03 "Final Submittals" have been satisfied.

#### 1.05 MAINTENANCE AND GUARANTEE

- A. The CONTRACTOR shall comply with all maintenance and guarantee requirements of the Contract Documents.
- B. Replacement of earth fill or backfill, where it has settled below the required finish elevations, shall be considered as a part of such required repair work, and any repair or resurfacing constructed by the CONTRACTOR which becomes necessary by reason of such settlement shall likewise be considered as a part of such required repair work unless the CONTRACTOR shall have obtained a statement in writing from the affected private CITY or public agency releasing the CITY from further responsibility in connection with such repair or resurfacing.
- C. The CONTRACTOR shall make all repairs and replacements promptly upon receipt of written order from the CITY. If the CONTRACTOR fails to make such repairs or replacements promptly, the CITY reserves the right to do the Work and the CONTRACTOR and his surety shall be liable to the CITY for the cost thereof.

#### 1.06 TOUCH-UP AND REPAIR

- A. The CONTRACTOR shall touch-up and repair damage to all field painted and factory finished equipment. Touch-up of equipment panels, etc., shall match as nearly as possible the original finish. If in the opinion of the ENGINEER the touch-up work is not

satisfactory, the CONTRACTOR shall repaint the item. CONTRACTOR shall also furnish additional paint as defined in Section 09900.

1.07 FINAL CLEANUP

- A. The CONTRACTOR shall promptly remove from the vicinity of the completed Work, all rubbish, unused materials, concrete forms, construction equipment, and temporary structures and facilities used during construction. Final acceptance of the Work by the CITY will be withheld until the CONTRACTOR has satisfactorily complied with the foregoing requirements for final cleanup of the project site.

PART 2 -- PRODUCTS (Not Used)

PART 3 -- EXECUTION (Not Used)

- END OF SECTION -

**DIVISION 2 – SITE WORK**

## SECTION 02050 - DEMOLITION

### PART 1 -- GENERAL

#### 1.01 THE REQUIREMENT

- A. The CONTRACTOR shall remove and dispose of or salvage any existing structure, piping, conduits, electrical equipment, mechanical equipment, or appurtenances or portions thereof, as shown on the Drawings or required to complete the project.
- B. All materials designated for disposal shall, when released by the ENGINEER, become the CONTRACTOR's property and shall be removed from the site and disposed of by the CONTRACTOR.
- C. All materials designated to be salvaged shall be carefully removed and moved to a city-designated location within the City of Hollywood.

#### 1.02 SUBMITTALS

- A. The CONTRACTOR shall submit for review, in accordance with Section entitled "Submittals" the proposed methods, equipment and operation sequence. Include coordination for shut-off, temporary services, continuation of service and other applicable items to ensure no interruption of operations except as herein before specified.

#### 1.03 JOB CONDITIONS

- A. Protection: The CONTRACTOR shall execute the demolition and removal work to prevent damage or injury to structures, occupants thereof and adjacent features which might result from falling debris or other causes, and so as not to interfere with the use, and free and safe passage to and from adjacent structures.
- B. Use of Explosives: The use of explosives is strictly prohibited on this project
- C. Closing or obstructing of roadways adjacent to the work by the placement or storage of materials will not be permitted. All operations shall be conducted with a minimum interference to traffic on these ways.
- D. The CONTRACTOR shall repair damage done to facilities to remain, or any property belonging to the CITY.
- E. Scheduling: The CONTRACTOR shall carry out his operations so as to avoid interference with operations and work in the existing facilities.
- F. Notification: At least 48 hours prior to commencement of a demolition or removal, the CONTRACTOR shall notify the CITY in writing of his proposed removal schedule. No removals shall be started until the schedule is acceptable to the CITY.



#### 1.04 PRE-DEMOLITION ASBESTOS SURVEY – NOT REQUIRED

- A. The CONTRACTOR is responsible for performing a Pre-Demolition Asbestos survey prior to the commencement of demolition activities at the site. This survey must be completed by a Florida licensed Asbestos Consultant. A copy of the survey shall be provided to the ENGINEER and CITY for informational purposes only.
- B. The CONTRACTOR is required to procure all permits related to demolition prior to the commencement of demolition activities at the site.

#### 1.05 DUST CONTROL

- A. The CONTRACTOR shall use temporary enclosures and other suitable methods to limit the amount of dust and dirt rising and scattering in the air to the lowest practical level. Existing electrical and mechanical equipment to remain shall be protected from damage, dust, and debris.

### PART 2 – PRODUCTS

(NOT USED)

### PART 3 -- EXECUTION

#### 3.01 GENERAL

- A. Prior to commencing work, the CONTRACTOR shall check all underground and exposed existing utility and process piping and all equipment in any way associated or in the proximity to the items to be removed and shall verify that the piping is inactive (abandoned) and that electric power to equipment, lighting, controls, etc., has been permanently disconnected. Active services shall be brought to the attention of the CITY for proper action.
- B. The CONTRACTOR shall remove all equipment and accessories in a workmanlike manner and shall take all necessary precautions to avoid damaging existing equipment, piping, and structure which are to be retained. Damages shall be repaired or replaced at the expense of the CONTRACTOR.
- C. The CONTRACTOR shall proceed with the removal of the structures, equipment, piping, and appurtenances in a sequence designed to maintain the facilities in continuous operation.
- D. All supports, pedestals, and anchors shall be removed with the equipment structures and piping unless otherwise specified or required. Concrete bases, anchor bolts, and other supports shall be removed in their entirety; and the recesses shall be patched to match the adjacent areas. Superstructure wall and roof openings shall be closed; damaged surfaces shall be patched to match the adjacent areas, as specified under applicable sections of these Specifications, and as shown on the Drawings, or as indicated by the ENGINEER. Wall sleeves and castings shall be cleared of extraneous materials and filled with non-shrink grout as recommended by manufacturer for watertightness required. All openings in concrete shall be closed in a manner meeting the

requirements of the appropriate sections of these Specifications, as shown on the Drawings, and as acceptable to the ENGINEER.

### 3.02 UNAUTHORIZED REMOVAL

- A. Any equipment, piping, and appurtenances removed without proper authorization, shall be replaced to the satisfaction of the ENGINEER at no cost to the CITY.

### 3.03 SALVAGED ITEMS

- A. Items to be salvaged as shown on the plans shall be tagged and shall remain the property of the CITY. The CONTRACTOR shall carefully move salvaged equipment to a CITY-designated location at the Southern Regional Wastewater Treatment Plant.

### 3.04 DEMOLITION

- A. All materials and equipment shown on the Drawings to be removed or demolished shall become the property of the CONTRACTOR, with the exception of items tagged to be salvaged and metal items tagged for recycling. Prior to removal of any existing equipment or piping from the site of work, the CONTRACTOR shall ascertain from the ENGINEER whether or not the particular item or items are to be salvaged or recycled. The CONTRACTOR shall dispose of all demolition materials, equipment, debris and all other items off the project site and in conformance with all existing applicable laws and regulations.

### 3.05 STRUCTURAL REMOVALS

- A. The CONTRACTOR shall remove structures to the lines and grades shown, unless otherwise indicated by the ENGINEER.
- B. All wood, concrete, brick, tile, concrete block, roofing materials, reinforcement, structural or miscellaneous metals, plaster, wire mesh and other items contained in or upon the structure shall be removed and taken from the project site. These items shall not be used in backfill.
- C. Finishes: After removal of parts or all of masonry walls, slabs and like work, which tie into new work or existing work, the point of junction shall be neatly repaired so as to leave only finished edges and surface exposed. The jambs, sills and heads of any new windows, passageways, doors or other openings cut into the new work or existing work shall be dressed with new masonry, concrete or metal to provide a smooth, finished appearance.
- D. Anchoring: Where new anchoring materials, including bolts, nuts, hangers, welds and reinforcing steel, are required to attach new work to the existing work, they shall be included under this Section, except where specified elsewhere.

### 3.06 MECHANICAL REMOVALS

- A. General: Mechanical removals shall consist of dismantling and removing of existing piping, equipment and other appurtenances as shown or required for the completion of the work. It shall include cutting, capping and plugging as required.

- B. Wherever piping is to be removed, adjacent pipe headers that are to remain in service shall be blanked off or plugged and then anchored in an acceptable manner.

### 3.07 ELECTRICAL REMOVALS

- A. General: Electrical removals shall consist of the removal of conduits and wires, and miscellaneous electrical equipment all as shown, specified or required to perform the work. All existing electrical equipment to be removed shall be removed with such care as maybe required to prevent unnecessary damage, to keep existing systems in operation and to keep the integrity of the grounding systems.

### 3.08 REPAIR WORK

- A. Certain areas of existing structures, piping, conduits, and the like will be affected by work necessary to complete modifications under this Contract. The CONTRACTOR shall be responsible to rehabilitate those areas affected by its construction activities.
- B. Where new rectangular openings are to be installed in concrete or concrete masonry walls or floors, the CONTRACTOR shall score the edges of each opening (both sides of wall or elevated slab) by saw cutting clean straight lines to a minimum depth of one inch and then chipping out the concrete. Alternately, the opening can be formed by saw cutting completely through the slab or wall. Saw cuts deeper than one inch (or the depth of cover over existing reinforcing steel, whichever is less) shall not be allowed to extend beyond the limits of the opening. Corners shall be made square and true by a combination of core drilling, chipping, or grinding. All necessary precautions shall be taken during removal of concrete to prevent debris from falling and damaging adjacent equipment or piping. Saw cuts allowed to extend beyond the opening shall be repaired by filling with nonshrink grout. The concrete around any exposed reinforcement steel shall be chipped back and exposed reinforcement steel cut a minimum of 1-1/2 inches from the finished face of the new opening. The inside face of the new opening shall be grouted to fill any voids and cover the exposed aggregate and shall be trowel-finished to provide a plumb and square opening.
- C. Where new conduit or piping is to be installed through existing concrete walls, the CONTRACTOR shall accurately position and core-drill openings. Openings shall be adequately sized to allow alignment of piping or conduit and fittings without deflection and to provide adequate clearance for satisfactory packing in the annular space between the piping or conduit and the core drilling opening as shown on the Drawings.
- D. Where new piping is to be connected to existing piping, the existing piping shall be cut square and the ends properly prepared for the connection shown on the drawings. Any damage to the lining and coating of the existing piping shall be repaired by the CONTRACTOR.
- E. Where existing equipment, equipment pads and bases, piping, piping supports, handrail, electrical panels and devices, conduits, and associated appurtenances are removed, the CONTRACTOR shall rehabilitate the affected area such that little or no evidence of the previous installation remains. Openings in concrete floors, walls, and ceiling from piping, conduit, fastener penetrations, etc., shall be filled with nonshrink grout and finished to match the adjacent area. Concrete pads and bases for equipment and supports shall be removed by chipping away concrete and cutting any exposed reinforced steel and anchor bolts a minimum of 1-1/2 inches below finished grade. The area of concrete to be

rehabilitated shall be scored by saw cutting clean, straight lines to a minimum depth of 1-1/2 inches, and all concrete within the scored lines removed to a minimum depth of 1-1/2 inches. The area within the scored lines shall be patched with nonshrink grout to match the adjacent grade and finish. Unless otherwise shown, abandoned connections to piping and conduits shall be terminated with blind flanges, caps, and plugs suited for the material, type, and service of the pipe or conduit. Walls shall be painted in accordance with requirements set forth in Section 09900 entitled "Painting".

F. Where existing structural steel members are removed or modified, the surface of the remaining existing steel members damaged by construction activities shall be repaired. The affected areas shall be surface prepared and coated in accordance with Section 09900 entitled "Painting".

G. Disposal of Debris

1. All debris, materials, piping, and miscellaneous waste products from the work described in this section shall be removed from the project as soon as possible. They shall be disposed of in accordance with applicable federal, state, and local regulations. The CONTRACTOR is responsible for determining these regulations and shall bear all costs or retain any profit associated with disposal of these items.

### 3.09 CLEANUP

A. The CONTRACTOR shall remove from the project site all debris resulting from the demolition and removal operations as it accumulates. Upon completion of the demolition work, all materials, equipment, waste and debris of every sort shall be removed and the premises shall be left clean, neat and orderly.

- END OF SECTION -

**DIVISION 3 – CONCRETE**

**NOT USED**

**DIVISION 4 – MASONRY**

**NOT USED**

**DIVISION 5 – METALS**

## SECTION 05010 - METAL MATERIALS

### PART 1 -- GENERAL

#### 1.01 THE REQUIREMENT

- A. Metal materials not otherwise specified shall conform to the requirements of this Section.

#### 1.02 RELATED WORK SPECIFIED ELSEWHERE

- A. Materials for fasteners are included in Section 05050 entitled "Metal Fastening".
- B. Requirements for specific products made from the materials specified herein are included in other sections of the Specifications. See the section for the specific item in question.

#### 1.03 REFERENCE SPECIFICATIONS, CODES AND STANDARDS

- A. ASTM A36                      Standard Specification for Structural Steel
- B. ASTM A47                      Standard Specification for Malleable Iron Castings
- C. ASTM A48                      Standard Specification for Gray Iron Castings
- D. ASTM A53                      Standard Specification for Pipe, Steel, Black and Hot-Dipped, Zinc-Coated Welded and Seamless
- E. ASTM A167                      Standard Specification for Stainless and Heat-Resisting Chromium-Nickel Steel Plate, Sheet, and Strip
- F. ASTM A276                      Standard Specification for Stainless and Heat-Resisting Steel Bars and Shapes
- G. ASTM A307                      Standard Specification for Carbon Steel Externally Threaded Standard Fasteners
- H. ASTM A446                      Standard Specification for Steel Sheet, Zinc-Coated (Galvanized) by the Hot-Dip Process, Structural (Physical) quality
- I. ASTM A500                      Standard Specification for Cold-Formed Welded and Seamless Carbon Steel Structural Tubing in Rounds and Shapes
- J. ASTM A501                      Standard Specification for Hot-Formed Welded and Seamless Carbon Steel Structural Tubing
- K. ASTM A529                      Standard Specification for Structural Steel with 42 000 psi (290 Mpa) Minimum Yield Point (1/2 in. (12.7 mm) Maximum Thickness)



- |    |                     |  |
|----|---------------------|--|
| L. | ASTM A536           | Standard Specification for Ductile Iron Castings   |
| M. | ASTM A570           | Standard Specification for Hot-Rolled Carbon Steel Sheet and Strip, Structural Quality                               |
| N. | ASTM A572/A572M-94C | Standard Specification for High Strength Low-Alloy Columbium-Vanadium Structural Steel Grade 50                      |
| O. | ASTM A666           | Standard Specification for Austenitic Stainless Steel, Sheet, Strip, Plate, and Flat Bar for Structural Applications |
| P. | ASTM B26            | Standard Specification for Aluminum-Alloy Sand Castings  |
| Q. | ASTM B85            | Standard Specification for Aluminum-Alloy Die Castings   |
| R. | ASTM B108           | Standard Specification for Aluminum-Alloy Permanent Mold Castings  |
| S. | ASTM B138           | Standard Specification for Manganese Bronze Rod, Bar, and Shapes   |
| T. | ASTM B209           | Standard Specification for Aluminum-Alloy Sheet and Plate  |
| U. | ASTM B221           | Standard Specification for Aluminum-Alloy Extruded Bars, Rods, Wire, Shapes, and Tubes                               |
| V. | ASTM B308           | Standard Specification for Aluminum-Alloy Standard Structural Shapes, Rolled or Extruded                             |
| W. | ASTM B574           | Standard Specification for Nickel-Molybdenum-Chromium Alloy Rod  |
| X. | ASTM F468           | Standard Specification for Nonferrous Bolts, Hex Cap Screws, and Studs for General Use                               |
- 1.04 SUBMITTALS
- A. Material certifications shall be submitted along with any shop drawings for metal products and fabrications required by other sections of the Specifications.
- 1.05 QUALITY ASSURANCE
- A. CITY may engage the services of a testing agency to test any metal materials for conformance with the material requirements herein. If the material is found to be in conformance with Specifications the cost of testing will be borne by the CITY. If the material does not conform to the Specifications, the cost of testing shall be paid by the CONTRACTOR and all materials not in conformance as determined by the ENGINEER shall be replaced by the CONTRACTOR at no additional cost to the CITY. In lieu of replacing materials the CONTRACTOR may request further testing to determine conformance, but any such testing shall be paid for by the CONTRACTOR regardless of outcome of such testing.

## PART 2 -- PRODUCTS

### 2.01 CARBON AND LOW ALLOY STEEL

A. Material types and ASTM designations shall be as listed below:

- |   |                                     |
|---|-------------------------------------|
| 1. Structural W Shapes                                      | A 992 (50 ksi)                      |
| 2. Structural S, M, C, L Shapes                             | A 36 (36 ksi)                       |
| 3. Structural HP Shape                                      | A 572, Grade 50 (50 ksi)            |
| 4. Structural Tubing  | A 500, Grade B or A 501 (42 ksi)    |
| 5. Structural Pipe  | A 53, Type E or S, Grade B (35 ksi) |
| 6. Plates and Bars  | A 36 U.N.O. (36 ksi)                |
| 7. Sheet Steel  | A 570, Grade C                      |
| 8. Cold-Formed Structural Studs and Joists<br>(18-22 gauge) | A 446, Grade C                      |
| 8. Cold-Formed Structural Studs and Joists<br>(12-16 gauge) | A 446, Grade D                      |

### 2.02 STAINLESS STEEL

A. All stainless steel fabrications shall be Type 316.

B. Material types and ASTM designations are listed below:

- |                      |                           |
|----------------------|---------------------------|
| 1. Plates and Sheets | ASTM A167 or A666 Grade A |
| 2. Structural Shapes | ASTM A276                 |

### 2.03 ALUMINUM

A. All aluminum shall be alloy 6061-T6, unless otherwise noted or specified herein.

B. Material types and ASTM designations are listed below:

- |                      |                        |
|----------------------|------------------------|
| 1. Structural Shapes | ASTM B308              |
| 2. Castings          | ASTM B26, B85, or B108 |
| 3. Extruded Bars     | ASTM B221 - Alloy 6061 |

- 4. Extruded Rods, Shapes and Tubes                      ASTM B221 - Alloy 6063
- 5. Plates    ASTM B209 - Alloy 6061
- 6. Sheets    ASTM B221 - Alloy 3003

- C. All aluminum shall be provided with mill finish unless otherwise noted.
- D. Where bolted connections are indicated, aluminum shall be fastened with Type 316 stainless steel bolts.
- E. Aluminum in contact with dissimilar materials shall be insulated with an approved dielectric.

2.04 CAST IRON

- A. Material types and ASTM designations are listed below:
  - 1. Gray    ASTM A48 Class 30B
  - 2. Malleable    ASTM A47
  - 3. Ductile    ASTM A536 Grade 60-40-18

2.05 BRONZE

- A. Material types and ASTM designations are listed below:
  - 1. Rods, Bars and Sheets                                      ASTM B138 - Alloy B Soft

2.06 HASTELLOY

- A. All Hastelloy shall be Alloy C-276.

PART 3 -- EXECUTION

(NOT USED)

- END OF SECTION -

## SECTION 05050 - METAL FASTENING

### PART 1 -- GENERAL

#### 1.01 THE REQUIREMENT

- A. The CONTRACTOR shall furnish all materials, labor, and equipment required to provide all metal welds and fasteners not otherwise specified, in accordance with the Contract Documents.

#### 1.02 RELATED WORK SPECIFIED ELSEWHERE

- A. Section 05010 - Metal Materials

#### 1.03 REFERENCE SPECIFICATIONS, CODES, AND STANDARDS

- A. Without limiting the generality of the other requirements of the specifications, all work herein shall conform to the applicable requirements of the following documents. All referenced specifications, codes, and standards refer to the most current issue available at the time of Bid.

1. Florida Building Code
2. AC 193 Acceptance Criteria for Mechanical Anchors in Concrete Elements
3. AC 308 Acceptance Criteria for Post-Installed Adhesive Anchors in Concrete Elements
4. ACI 318 Building Code Requirements for Structural Concrete
5. ACI 355.2 Qualifications of Post-Installed Mechanical Anchors in Concrete
6. AISC 348 The 2009 RCSC Specification for Structural Joints
7. AISC Specification for Structural Joints Using ASTM A325 or A490 Bolts.
8. AISC Code of Standard Practice
9. AWS D1.1 Structural Welding Code - Steel
10. AWS D1.2 Structural Welding Code – Aluminum
11. AWS D1.6 Structural Welding Code – Stainless Steel
12. Aluminum Association Specifications for Aluminum Structures

- |     |                     |   |
|-----|---------------------|---|
| 13. | ASTM A572/A572M-94C | Standard Specification for High Strength Low-Alloy Columbium-Vanadium Structural Steel Grade 50 |
| 14. | ASTM A36            | Standard Specification for Carbon Structural Steel  |
| 15. | ASTM A307           | Standard Specification for Carbon Steel Externally Threaded Standard Fasteners                  |
| 16. | ASTM A325           | Standard Specification for High-Strength Bolts for Structural Steel Joints                      |
| 17. | ASTM E488           | Standard Test Methods for Strength of Anchors in Concrete and Masonry Elements                  |
| 18. | ASTM F436           | Standard Specification for Hardened Steel Washers   |
| 19. | ASTM A489           | Standard Specification for Eyebolts   |
| 20. | ASTM A490           | Standard Specification for Quenched and Tempered Alloy Steel Bolts for Structural Steel Joints  |
| 21. | ASTM A563           | Standard Specifications for Carbon and Alloy Steel Nuts   |
| 22. | ASTM F593           | Standard Specification for Stainless Steel Bolts; Hex Cap Screws, and Studs                     |
| 23. | ASTM F594           | Standard Specification for Stainless Steel Nuts   |
| 24. | ASTM D1785          | Standard Specification for Polyvinyl Chloride (PVC) Plastic Pipe                                |
| 25. | ASTM F1554          | Standard Specification for Anchor Bolts, Steel, 36, 55, and 105-ksi Yield Strength              |

#### 1.04 SUBMITTALS

- A. Submit the following items in accordance with Section 01300 entitled "Submittals":
1. Shop Drawings providing the fastener's manufacturer and type and certification of the fastener's material and capacity.
  2. Anchor design calculations sealed by a Professional Engineer currently registered in the State of Florida. Only required if design not shown on Contract Drawings.
  3. Manufacturer's installation instructions.
  4. Welder certifications for each person who is to perform field welding. Certifications shall be from a recognized testing laboratory.

5. Certified weld inspection reports, when required.
6. Welding procedures.
7. Installer qualifications of post-installed anchors
8. Certification of Installer Training
9. Inspection Reports
10. Results of Anchor Proof Testing
11. For outdoor equipment, anchorage calculations to resist design wind loads, signed and sealed by a Professional Engineer registered in the State of Florida.

#### 1.05 QUALITY ASSURANCE

- A. Fasteners not manufactured in the United States shall be tested and certification provided with respect to specified quality and strength standards. Certifications of origin shall be submitted for all U.S. fasteners supplied on the project.
- B. Installer Qualifications: All concrete anchors shall be installed by an Installer with at least three years of experience performing similar installations. Installer shall be certified as an Adhesive Anchor Installer in accordance with ACI-CRSI Adhesive Anchor Installation Certification Program.
- C. Installer Training: For concrete adhesive anchors, conduct a thorough training with the manufacturer or the manufacturer's representative for the Installer on the project. Training shall consist of a review of the complete installation process for drilled-in anchors, to include but not be limited to the following:
  1. Hole drilling procedure.
  2. Hole preparation and cleaning technique.
  3. Adhesive injection technique and dispenser training/maintenance.
  4. Rebar doweling preparation and installation.
  5. Proof loading/torquing.
- D. All steel welding shall be performed by welders certified in accordance with AWS D1.1. All aluminum welding shall be performed by welders certified in accordance with AWS D1.2. All stainless steel welding shall be performed by welders certified in accordance with AWS D1.6. Certifications of field welders shall be submitted prior to performing any field welds.
- E. Welds and high strength bolts used in connections of structural steel will be visually inspected in accordance with Article 3.04 of this Section.

- F. The CITY may engage an independent testing agency to perform testing of welded connections and to prepare test reports in accordance with AWS. Inadequate welds shall be corrected or redone and retested to the satisfaction of the ENGINEER and/or an acceptable independent testing laboratory, at no additional cost to the CITY.
- G. Provide a welding procedure for each type and thickness of weld. For welds that are not prequalified, include a Performance Qualification Report. The welding procedure shall be given to each welder performing the weld. The welding procedure shall follow the format in Annex E of AWS D1.1 with relevant information presented.
- H. Inspections of the adhesive dowel system shall be made by the Engineer or other representatives of the Owner in accordance with the requirements of the ESR published by the manufacturer. Provide adequate time and access for inspections of products and anchor holes prior to injections, installation, and proof testing.

## PART 2 -- PRODUCTS

### 2.01 ANCHOR RODS (ANCHOR BOLTS)

- A. For all conditions throughout this Contract, all anchor bolts shall be Type 316 stainless steel conforming to ASTM F-593 unless noted otherwise.
- B. Nuts shall conform to ASTM F-594, alloy 316.
- C. Where anchor rods are used to anchor galvanized steel or are otherwise specified to be galvanized, anchor rods and nuts shall be hot-dip galvanized in accordance with ASTM F1554.
- D. Where pipe sleeves around anchor rods are shown on the Drawings, pipe sleeves shall be cut from Schedule 80 PVC plastic piping meeting the requirements of ASTM D1785, unless noted otherwise.
- E. Equipment manufacturers, fabricators, and suppliers shall design and furnish anchor bolts as required to install the supplied units. The anchor bolt layout shall be coordinated with concrete work as specified herein.
- F. Drilled in type anchor bolts, either adhesive types or mechanical types shall not be used unless approved in writing by the manufacturer/fabricator of equipment or covers, subject to acceptance by the ENGINEER. All operating pieces of equipment such as pumps, generators, motors etc. shall not be anchored with wedge anchors or other mechanical anchors. Drilled in type anchor bolts shall be Type 316 stainless steel. Drilled in type anchor bolts are specified under Article 2.04 of this Section entitled "Concrete Anchors".

### 2.02 HIGH STRENGTH BOLTS

- A. High strength bolts and associated nuts and washers shall be in accordance with ASTM A325 or ASTM A490. Bolts, nuts and washers shall meet the requirements of AISC "Specification for Structural Joints Using ASTM A325 or A490 Bolts".

- B. Where high strength bolts are used to connect galvanized steel or are otherwise specified to be galvanized, bolts, nuts, and washers shall be hot-dip galvanized in accordance with ASTM A325.

## 2.03 STAINLESS STEEL BOLTS

- A. Stainless steel bolts shall conform to ASTM F-593. All underwater fasteners shall be Type 316 stainless steel. Unless otherwise specified, fasteners for aluminum and stainless steel members shall be Type 316 stainless steel.
- B. Stainless steel bolts shall have hexagonal heads with a raised letter or symbol on the bolts indicating the manufacturer, and shall be supplied with hexagonal nuts meeting the requirements of ASTM F594. Nuts shall be of the same alloy as the bolts.

## 2.04 CONCRETE ANCHORS

### A. General

1. Where concrete anchors are called for on the Drawings, one of the types listed below shall be used; except, where one of the types listed below is specifically called for on the Drawings, only that type shall be used. Unless otherwise noted, all concrete anchors which are submerged, or are used in hanging items or have direct tension induced upon them, or which are subject to vibration from equipment such as pumps and generators, shall be adhesive anchors. The determination of anchors equivalent to those listed below shall be on the basis of test data performed by an approved independent testing laboratory. There are two types used:
  - a. Expansion anchors shall be mechanical anchors of the wedge, sleeve, drop-in or undercut type.
  - b. Adhesive anchors shall consist of threaded rods or bolts anchored with an adhesive system into hardened concrete. Adhesive anchors shall be two part injection type using the manufacturer's static mixing nozzle and shall be supplied as an entire system.
2. Expansion anchors shall not be used to hang items from above or in any other situation where direct tension forces are induced in anchor.
3. Unless otherwise noted, all concrete anchors which are submerged or are used in hanging items or have direct tension induced upon them, or which are subject to vibration from equipment such as pumps and generators, shall be adhesive anchors.
4. Adhesive anchors shall conform to the requirements of ACI 355.4 or alternately to AC308. Expansion or mechanical anchors shall conform to the requirements of ACI 355.2 or alternately to AC 193.
5. All anchors installed within fire resistant construction shall either be enclosed in a fire resistant envelope, be protected by approved fire-resistive materials, be used to resist wind loads only, or anchor non-structural elements.



## B. Concrete Anchor Design

An anchor design consists of specifying anchor size, quantity, spacing, edge distance and embedment to resist all applicable loads. Where an anchor design is indicated on the Drawings, it shall be considered an engineered design and anchors shall be installed to the prescribed size, spacing, embedment depth and edge distance. If all parts of an anchor design are provided on the Drawings except embedment depth, the anchors will be considered an engineered design and the Contractor shall provide the embedment depth as indicated in Paragraph B.3 unless otherwise directed by the Engineer. Where an anchor design is not indicated by the Engineer on the Drawings, the Contractor shall provide the anchor design per the requirements listed below.

1. **Structural Anchors:** All concrete anchors shall be considered structural anchors if they transmit load between structural elements; transmit load between non-structural components that make up a portion of the structure and structural elements; or transmit load between life-safety related attachments and structural elements. Examples of structural concrete anchors include but are not limited to column anchor bolts, anchors supporting non-structural walls, sprinkler piping support anchors, anchors supporting heavy, suspended piping or equipment, anchors supporting barrier rails, etc. For structural anchors, the Contractor shall submit an engineered design with signed and sealed calculations performed by an Engineer currently registered in the State of Florida. Structural anchors shall be of a type recommended by the anchor manufacturer for use in cracked concrete and shall be designed by the Contractor in accordance with ACI 318 Appendix D.
2. **Non-Structural Anchors:** All other concrete anchors may be considered non-structural concrete anchors. The Contractor shall perform an engineered design for non-structural anchors. The Engineer may request the Contractor provide anchor design details for review, but submission of a signed, sealed design is not required. Non-structural anchors shall be designed by the contractor for use in uncracked concrete.
3. **Minimum anchor embedment** shall be as indicated on the Drawings or determined by the Contractor's engineered design. Concrete anchors shall be embedded no less than the manufacturer's standard embedment (expansion or mechanical anchors) or to provide a minimum allowable bond strength equal to the allowable yield capacity of the rod/bolt (adhesive anchors).

## C. Structural Anchors:

1. **Mechanical Anchors:**
  - a. **Wedge Anchors:** Wedge anchors shall be "Kwik Bolt TZ" by Hilti, Inc., "TruBolt +" by ITW Redhead, "Strong-Bolt" or "Strong-Bolt 2" by Simpson Strong-Tie Co. or "Powerstud SD-1" or "Powerstud SD-2" by Powers Fasteners.

- b. Screw Anchors: Screw anchors shall be “Kwik HUS-EZ” and “KWIK HUS-EZ-I” by Hilti, Inc., “Titen HD” by Simpson Strong-Tie Co., or “Wedge-Bolt +” by Powers Fasteners. Bits specifically provided by manufacturer of chosen system shall be used for installation of anchors.
- c. Sleeve Anchors: Sleeve anchors shall be “HSL-3 Heavy Duty Sleeve Anchor” by Hilti, Inc. or “Power-Bolt +” by Powers Fasteners.
- d. Undercut Anchors: Undercut anchors shall be “HDA Undercut Anchor” by Hilti, Inc., “Torq-Cut Undercut Anchor” by Simpson Strong-Tie Co., “Atomic + Undercut Anchor” by Powers Fasteners

2. Adhesive Anchors:

- a. Adhesive anchors shall be “Epcon C6+ Adhesive Anchoring System” by ITW Redhead, “HIT HY-200 Adhesive Anchoring System” by Hilti, Inc., “SET-XP Epoxy Adhesive Anchors” by Simpson Strong-Tie Co., or “Pure 110+ Epoxy Adhesive Anchor System” by Powers Fasteners.
- b. Structural adhesive anchor systems shall be IBC compliant and capable of resisting short term wind and seismic loads (Seismic Design Categories A through F) as well as long term and short term sustained static loads in both cracked and uncracked concrete in all Seismic Design Categories. Structural adhesive anchor systems shall comply with the latest revision of ICC-ES Acceptance Criteria AC308, and shall have a valid ICC-ES report in accordance with the applicable building code. No or equal products will be considered unless prequalified and approved by the Engineer and Owner.

D. Non-Structural Anchors: In addition to the acceptable non-structural anchors listed below, all structural anchors listed above may also be used as non-structural anchors.

1. Mechanical Anchors:

- a. Wedge Anchors: Wedge anchors shall be “Kwik Bolt 3” by Hilti, Inc. or “TruBolt” by ITW Redhead.
- b. Screw Anchors: Screw anchors shall be “Kwik HUS” by Hilti, Inc., “Wedge-Bolt” by Powers Fasteners or “Large Diameter Tapcon (LDT) Anchor” by ITW Redhead. Bits specifically provided by manufacturer of chosen system shall be used for installation of anchors.
- c. Sleeve Anchors: Sleeve anchors shall be “HSL Heavy Duty Sleeve Anchors” by Hilti, Inc. “Power-Bolt” by Powers Fasteners or “Dynabolt Sleeve Anchor” by ITW Redhead.
- d. Drop-In Anchors: Drop-in anchors shall be “Drop-In” by Simpson Strong-Tie Co., “HDI Drop-In Anchor” by Hilti, Inc. or “Multi-Set II Drop-In Anchor” by ITW Redhead.

- e. Undercut Anchors: Undercut anchors shall be “HDA Undercut Anchor” by Hilti, Inc.
2. Adhesive Anchors:
- a. Adhesive anchors shall be “Epcon A7” or “Epcon C6+ Adhesive Anchoring System” by ITW Redhead, “HIT HY-200 Adhesive Anchoring System” by Hilti, Inc., “SET Epoxy Tie High Strength Anchoring Adhesive” or “AT High Strength Anchoring Adhesive” by Simpson Strong-Tie Co., or “Powers AC 100+ Gold Vinylester Injection Adhesive Anchoring System” or “T308+ Epoxy Adhesive Injection System” by Powers Fasteners.
  - b. Non-structural adhesive anchors systems shall be IBC compliant and capable of resisting short term wind and seismic (Seismic Design Categories A and B) as well as long term and short term sustained static loads in uncracked concrete
  - c. Non-structural adhesive anchor embedment depth of the rod/bolt shall provide a minimum allowable bond strength that is equal to the allowable yield capacity of the rod/bolt unless noted otherwise on the Drawings.
  - d. No or equal products will be considered unless prequalified and approved by the Engineer and Owner.

E. Concrete Anchor Rod/Bolt Materials:

- 1. Concrete anchors used to anchor structural steel shall be a threaded steel rod per manufacturer’s recommendations for proposed adhesive system, but shall not have a yield strength ( $f_y$ ) less than 58 ksi nor an ultimate strength ( $f_u$ ) less than 72.5 ksi, unless noted otherwise. Where steel to be anchored is galvanized, concrete anchors shall also be galvanized unless otherwise indicated on the Drawings.
- 2. Concrete anchors used to anchor aluminum, FRP, or stainless steel shall be Type 304 stainless steel unless noted otherwise. All underwater concrete anchors shall be Type 316 stainless steel.
- 3. Nuts, washers, and other hardware shall be of a material to match the anchors.

2.05 MASONRY ANCHORS

- A. Anchors for fastening to solid or grout-filled masonry shall be adhesive anchors as specified above for concrete anchors.
- B. Anchors for fastening to hollow masonry or brick shall be adhesive anchors consisting of threaded rods or bolts anchored with an adhesive system dispensed into a screen tube inserted into the masonry. The adhesive system shall use a two-component adhesive mix and shall inject into the screen tube with a static mixing nozzle. Thoroughly clean

drill holes of all debris and drill dust with nylon (not wire) brush prior to installation of adhesive and anchor. Contractor shall follow manufacturer's installation instructions. The adhesive system shall be "Epcon System A7 or C6" as manufactured by ITW Ramset/Redhead, "HIT HY-70 System" as manufactured by Hilti, Inc., "SET Epoxy-Tie" or "AT Acrylic-Tie" as manufactured by Simpson Strong-Tie Co., or "AC-100+ Gold by Powers Fasteners.

- C. Masonry anchors used to anchor steel shall be a threaded steel rod per manufacturer's recommendations for proposed adhesive system, but shall not have a yield strength (fy) less than 58 ksi nor an ultimate strength (fu) less than 72.5 ksi, unless noted otherwise. All masonry anchors shall be Type 316 stainless steel except where steel to be anchored is galvanized, masonry anchors shall also be galvanized.
- D. Masonry anchors used to anchor aluminum, FRP, or stainless steel shall be Type 316 stainless steel unless noted otherwise.

## 2.06 WELDS

- A. Electrodes for welding structural steel and all ferrous steel shall comply with AWS Code, using E70 series electrodes for shielded metal arc welding (SMAW), or F7 series electrodes for submerged arc welding (SAW).
- B. Electrodes for welding aluminum shall comply with the Aluminum Association Specifications and AWS D1.2.
- C. Electrodes for welding stainless steel and other metals shall comply with AWS code.

## 2.07 WELDED STUD CONNECTORS

- A. Welded stud connectors shall conform to the requirements of AWS D1.1 Type C.

## 2.08 EYEBOLTS

- A. Eyebolts shall conform to ASTM A489 unless noted otherwise.

## 2.09 HASTELLOY FASTENERS

- A. Hastelloy fasteners and nuts shall be constructed of Hastelloy C-276.

## 2.10 ANTISEIZE LUBRICANT

- A. Antiseize lubricant shall be Graphite 50 Anti-Seize by Loctite Corporation, 1000 Anti-Seize Paste by Dow Corning, 3M Lube and Anti-Seize by 3M, or equal.

## PART 3 -- EXECUTION

### 3.01 MEASUREMENTS

- A. The CONTRACTOR shall verify all dimensions and review the Drawings and shall report any discrepancies to the ENGINEER for clarification prior to starting fabrication.

### 3.02 BOLT INSTALLATION

#### A. Anchor Bolts, Concrete Anchors, and Masonry Anchors

1. Anchor bolts shall be installed in accordance with AISC "Code of Standard Practice" by setting in concrete while it is being placed and positioned by means of a rigidly held template.
2. The CONTRACTOR shall verify that all concrete and masonry anchors have been installed in accordance with the manufacturer's recommendations and that the capacity of the installed anchor meets or exceeds the specified safe holding capacity.
3. Concrete anchors shall not be used in place of anchor bolts without ENGINEER's approval.
4. All stainless steel threads shall be coated with antiseize lubricant.

#### B. High Strength Bolts

1. All bolted connections for structural steel shall use high strength bolts. High strength bolts shall be installed in accordance with AISC "Specification for Structural Joints, using A325 or A490 Bolts." All high strength bolts installed by the "turn-of-nut" method shall have the turned portion marked with reference to the steel being connected after the nut has been made snug and prior to final tightening. These marks will be considered in inspection.
2. All stainless steel bolts shall be coated with antiseize lubricant.

#### C. Concrete Anchors

1. Concrete at time of anchor installation shall be a minimum age of 21 days.
2. Concrete anchors designed by the Contractor shall be classified as structural or non-structural based on the requirements indicated above.
3. Concrete Anchor Testing:
  - a. At all locations where concrete anchors meet the requirements for structural anchors at least 5 percent of all concrete anchors installed shall be proof tested to the value indicated on the Drawings, with a minimum of one tested anchor per anchor group. If no test value is indicated on the Drawings but the installed anchor meets the requirements for structural anchors, the Contractor shall notify the Engineer to allow verification of whether anchor load proof testing is required.
  - b. Contractor shall submit a plan and schedule indicating locations of anchors to be tested, load test values and proposed anchor testing procedure (including a diagram of the testing equipment proposed for use) to the Engineer for review prior to conducting any testing. Testing of

anchors shall be in accordance with ASTM E488 for the static tension test. If additional tests are required, inclusion of these tests shall be as stipulated on Contract Drawings.

- c. Where Contract Documents indicate anchorage design to be the Contractor's responsibility and the anchors are considered structural per the above criteria, the Contractor shall submit a plan and schedule indicating locations of anchors to be proof tested and load test values, sealed by a Professional Engineer currently registered in the State of Florida. The Contractor's Engineer shall also submit documentation indicating the Contractor's testing procedures have been reviewed and the proposed procedures are acceptable. Testing procedures shall be in accordance with ASTM E488.
  - d. Concrete Anchors shall have no visible indications of displacement or damage during or after the proof test. Concrete cracking in the vicinity of the anchor after loading shall be considered a failure. Anchors exhibiting damage shall be removed and replaced. If more than 5 percent of tested anchors fail, then 100 percent of anchors shall be proof tested.
  - e. Proof testing of concrete anchors shall be performed by an independent testing laboratory hired directly by the Contractor and approved by the Engineer. The Contractor shall be responsible for costs of all testing, including additional testing required due to previously failed tests.
4. All concrete anchors shall be installed in strict conformance with the manufacturer's printed installation instructions. A representative of the manufacturer shall be on site when required by the Engineer.
  5. All holes shall be drilled with a carbide bit unless otherwise recommended by the manufacturer. No cored holes shall be allowed unless specifically approved by the Engineer. If coring holes is allowed by the manufacturer and approved by the Engineer, cored holes shall be roughened in accordance with manufacturer requirements. Thoroughly clean drill holes of all debris and drill dust with compressed air followed by a wire brush prior to installation of adhesive and threaded rod/bolt unless otherwise recommended by the manufacturer. Degree of hole dampness shall be in strict accordance with manufacturer recommendations. Where depth of hole exceeds the length of the static mixing nozzle, a plastic extension hose shall be used to ensure proper adhesive injection from the back of the hole. Injection of adhesive into the hole shall utilize a piston plug to minimize the formation of air pockets. Wipe rod free from oil that may be present from shipping or handling.

#### D. Other Bolts

1. All dissimilar metal shall be connected with appropriate fasteners and shall be insulated with a dielectric or approved equal. Unless otherwise specified, where aluminum and steel members are connected together they shall be fastened with Type 316 stainless steel bolts and insulated with micarta, nylon, rubber, or equal.

### 3.03 WELDING

- A. All welding shall comply with AWS Code for procedures, appearance, quality of welds, qualifications of welders and methods used in correcting welded work.
- B. Welded stud connectors shall be installed in accordance with AWS D1.1.

#### 3.04 INSPECTION

- A. High strength bolting will be visually inspected in accordance with AISC 348 "The 2009 RCSC Specification for Structural Joints". Rejected bolts shall be either replaced or retightened as required. In cases of disputed bolt installation, the bolts in question shall be checked by a calibrated wrench certified by an independent testing laboratory. The certification shall be at the CONTRACTOR's expense.
- B. Field welds will be visually inspected in accordance with AWS Codes. Inadequate welds shall be corrected or redone as required in accordance with AWS Codes.
- C. Inspection of post installed anchors shall be per requirements of the corresponding ICC ES ER.

- END OF SECTION -

## SECTION 05500 - METAL FABRICATIONS

### PART 1 -- GENERAL

#### 1.01 THE REQUIREMENT

- A. The CONTRACTOR shall furnish, fabricate, and install miscellaneous metalwork and appurtenances, complete, all in accordance with the requirements of the Contract Documents.

#### 1.02 RELATED WORK SPECIFIED ELSEWHERE

- A. Section 05050 - Metal Fastening
- B. Section 09900 - Painting

#### 1.03 REFERENCE SPECIFICATIONS, CODES, AND STANDARDS

- A. Without limiting the generality of other requirements of these Specifications, all work specified herein shall conform to or exceed the requirements of the Florida Building Code and the applicable requirements of the following documents to the extent that the provisions of such documents are not in conflict with the requirements of this Section:

1. American Society for Testing and Materials (ASTM), specifications as referred to herein.
2. American Welding Society (AWS) "Structural Welding Code-Steel" (AWS D1.1) which includes qualification procedures for welders.
3. American Institute of Steel Construction (AISC) "Specifications for the Design, Fabrication, and Erection of Structural Steel for Buildings" and "Commentary on the AISC Specification."
4. American Iron and Steel Institute (AISI) "Specifications for the Design of Cold-Formed Steel Structural Members" and "Commentary on the AISI Specification."
5. Occupational Safety and Health Administration (OSHA) Regulations.
6. Aluminum Association "Specifications for Aluminum Structures" and "Engineering Data for Aluminum Structures."
7. National Association of Architectural Metal Manufacturers "Metal Stairs Manual."

- B. References herein to "Building Code" shall mean the Florida Building Code.

#### 1.04 SUBMITTALS

- A. Shop drawings of all miscellaneous metalwork shall be submitted to the ENGINEER for review in accordance with the Section 01300 entitled "Submittals."



- B. Safe working load capacity in tension and shear for each size and type of concrete anchor used shall be submitted to the ENGINEER for review.

## PART 2 -- PRODUCTS

### 2.01 METAL MATERIALS

- A. Materials are specified in Section 05010 entitled "Metal Materials".

### 2.02 BOLTS, CONCRETE ANCHORS AND FASTENERS

- A. Bolts, concrete anchors and other fasteners are specified in Section 05050 entitled "Metal Fastening".

### 2.03 STEEL PIPE BUMPER GUARDS

- A. Steel pipe bumper guards shall be as detailed on the Drawings, including pipe sleeves, concrete fill, crushed fill and grouting to secure parts. Pipe for guards shall be galvanized steel, Schedule 40 pipe that conforms to ASTM A53. Painting shall be in accordance with Section 09900 entitled "Painting".
- B. Steel pipe bumper guards shall be concrete filled and crowned, as detailed on the Drawings.

## PART 3 -- EXECUTION

### 3.01 EXAMINATION

- A. Verify that field conditions are acceptable and are ready to receive work.
- B. Beginning of installation means erector accepts existing conditions.

### 3.01 FABRICATION

- A. All measurements and dimensions shall be based on field conditions and shall be verified by the CONTRACTOR prior to fabrication. Such verification shall include coordination with adjoining work.
- B. All fabricated work shall be shop fitted together as much as practicable, and delivered to the field, complete and ready for erection. All miscellaneous items such as stiffeners, fillets, connections, brackets, and other details necessary for a complete installation shall be provided.
- C. All work shall be fabricated and installed in a manner that will provide for expansion and contraction, prevent shearing of bolts, screws, and other fastenings, ensure rigidity, and provide a close fit of sections.
- D. Finished members shall conform to the lines, angles, and curves shown on the Drawings and shall be free from distortions of any kind.

- E. All shearings shall be neat and accurate, with parts exposed to view neatly finished. Flame cutting is allowed only when performed utilizing a machine.
- F. All shop connections shall be welded unless otherwise indicated on the Drawings or specified herein. Bolts and welds shall conform to Section 05050, Metal Fastening. All fastenings shall be concealed where practicable.
- G. Fabricated items shall be shop painted when specified in Section 09900, Painting.

### 3.02 PREPARATION

- A. Clean and strip primed steel items to bare metals where site welding is required.
- B. Supply items required to be cast into concrete with setting templates, to appropriate sections.

### 3.03 INSTALLATION

- A. Install items plumb and level, accurately fitted, free from distortion or defects.
- B. Allow for erection loads, and for sufficient temporary bracing to maintain true alignment until completion of erection and installation of permanent attachments.
- C. Field weld components indicated on Drawings.
- D. Obtain ENGINEER approval prior to site cutting or making adjustments not scheduled.
- E. Fabrication and Erection: Except as otherwise shown, the fabrication and erection of structural steel shall conform to the requirements of the American Institute of Steel Construction "Manual of Steel Construction."

### 3.04 WELDING

- A. All welding shall be by the metal-arc method or gas-shielded arc method as described in the American Welding Society's "Welding Handbook" as supplemented by other pertinent standards of the AWS. Qualification of welders shall be in accordance with the AWS Standards governing same.
- B. In assembly and during welding, the component parts shall be adequately clamped, supported and restrained to minimize distortion and for control of dimensions. Weld reinforcement shall be as specified by the AWS Code. Upon completion of welding, all weld splatter, flux, slag, and burrs left by attachments shall be removed. Welds shall be repaired to produce a workmanlike appearance, with uniform weld contours and dimensions. All sharp comers of material which is to be painted or coated shall be ground to a minimum of 1/32-inch on the flat.

- END OF SECTION -

## SECTION 05520 - HANDRAILS AND RAILINGS

### PART 1 -- GENERAL

#### 1.01 THE REQUIREMENT

- A. The CONTRACTOR shall furnish, fabricate, and install handrails and railings and appurtenances, complete, all in accordance with the requirements of the Contract Documents.

#### 1.02 RELATED WORK SPECIFIED ELSEWHERE

- A. Section 05010 - Metal Materials
- B. Section 05500 - Metal Fabrications

#### 1.03 REFERENCE SPECIFICATIONS, CODES, AND STANDARDS

- A. Without limiting the generality of the other requirements of the specifications, all work specified herein shall conform to or exceed the requirements of the Florida Building Code, and the applicable requirements of the following documents to the extent that the provisions of such documents are not in conflict with the requirements of this Section. All referenced specifications, codes, and standards refer to the most current issue available at the time of Bid.
  - 1. Florida Building Code
  - 2. Aluminum Association Specifications for Aluminum Structures
  - 3. Occupational Safety and Health Administration (OSHA) Regulations

#### 1.04 SUBMITTALS

- A. Shop drawings of all handrails and railings shall be submitted to the ENGINEER for review in accordance with Section 01300 entitled "Submittals."

#### 1.05 QUALITY ASSURANCE

- A. Single-Source Responsibility: Obtain handrails and railing systems from a single manufacturer.

### PART 2 -- PRODUCTS

#### 2.01 ALUMINUM RAILING SYSTEM

- A. General: Where indicated on the Drawings, pipe guardrailing shall be provided. Pipe guardrailing and handrailing shall be supplied as required by the Florida Building Code and OSHA whether indicated on the Drawings or not, and shall consist of all railings, posts, toeboards, baseplates, anchors, and accessories required for a complete and rigid

installation.

1. All metal railing systems shall be fabricated from extruded aluminum alloy 6061-T6 or 6105-T5, with Aluminum Association M12C22A41 clear anodized finish, unless noted otherwise.
- B. Vertical pipe supports shall include cast aluminum base flange or side mount bracket with set screws as indicated on Drawings and as manufactured by Thompson Fabricating, Hollaender, or approved equal. Removable posts shall be sleeved.
- C. Wall brackets for handrail shall be of designs indicated on the Drawings and shall be as manufactured by Moultrie Manufacturing Company, J.G. Braun Company, Fulton Metal Products Company, or equal.
- D. All connections between vertical posts and horizontal railing or between sections of horizontal railings shall be shop welded continuous in as long of sections as practical. Tack welds shall not be accepted. All welds shall be water tight and ground smooth. Field assembly of welded sections may be made by mechanical fasteners. Location and type of field connections shall be subject to the ENGINEER's review. Weep holes shall be shop drilled in all vertical posts of external railing.
- E. Design Load: All components of the railings and the railing system shall be adequately designed to resist the design loads of the Florida Building Code. In no case shall the spacing of vertical pipe supports exceed five feet.
- F. Aluminum Railing: Guardrail railing Posts shall be nominal 1-1/2 inch nominal diameter, Schedule 80 (minimum) aluminum alloy 6061-T6. Horizontal guardrail railing shall be 1-1/2 inch nominal diameter, Schedule 40 (minimum) aluminum pipe sections. Handrail railing shall be a maximum 1-1/2 inch outer diameter, Schedule 40 (minimum) aluminum pipe section. Stainless steel railing may be used in lieu of aluminum railing at the CONTRACTOR's option at no additional cost to the CITY.
- G. Kickplates: Kickplates shall be furnished and installed typically at the edges of all walkways and at other handrail installations. Kickplates shall be 1/4-inch thick, must meet OSHA requirements, shall project 4-inches above walkway surface, may not infringe on minimum required walkway width and must be of the same material as that of the handrail construction. Kickplates shall be connected to handrail posts as detailed on the drawings.
- H. Expansion joint splices shall be provided at 30 feet maximum spacing and at all expansion joints in the structure supporting the handrail. Material for expansion joint splice shall be the same as railing material.
- I. Where safety chains are required in handrails as shown on the Drawings, chains shall be constructed of Type 304 stainless steel. Chains shall be straight link style, 3/16-inch diameter, with at least twelve links per foot, and with snap hooks on each end. Snap 3/4-inch eye diameter welded to the railing posts. Two (2) chains, four inches longer than the anchorage spacing shall be supplied for each guarded area.

## 2.02 FASTENERS

- A. Fasteners when required or specified shall be Type 316 stainless steel.

### PART 3 -- EXECUTION

#### 3.01 EXAMINATION

- A. Verify that field conditions are acceptable and are ready to receive work.
- B. Beginning of installation means erector accepts existing conditions.

#### 3.02 PREPARATION

- A. Clean and strip primed items to bare metals where site welding is required.
- B. Supply items required to be cast into concrete with setting templates, to appropriate sections.

#### 3.03 INSTALLATION

- A. Install items plumb and level, accurately fitted, free from distortion or defects.
- B. Provide anchors and plates required for connecting railings to structure.
- C. Aluminum Railings: Aluminum railing fabrication shall be performed by craftsmen experienced in the fabrication of architectural metal work. Exposed surfaces shall be free from defects or other surface blemishes. Dimensions and conditions shall be verified in the field. All joints, junctions, miters and butting sections shall be precision fitted with no gaps occurring between sections, and with all surfaces flush and aligned. Electrolysis protection of materials shall be provided. All dissimilar materials shall be isolated.

#### 3.04 EXPANSION BOLTS

- A. Expansion bolts shall be spaced 10d apart and 6d edge distance (d=diameter of bolt). A safety factor of four shall be provided on expansion bolt pull out values published by the manufacturer.

#### 3.05 ALUMINUM SURFACES

- A. Aluminum surfaces in contact with concrete, grout or dissimilar metals shall be protected with a coat of bitumastic or other approved materials.

- END OF SECTION -

## SECTION 05531 - GRATING, FLOOR PLATES AND ACCESS HATCHES

### PART 1 -- GENERAL

#### 1.01 THE REQUIREMENT

- A. The CONTRACTOR shall furnish, fabricate, and install gratings and floor plates and appurtenances, complete, all in accordance with the requirements of the Contract Documents.

#### 1.02 RELATED WORK SPECIFIED ELSEWHERE

- A. Section 05500 - Metal Fabrications
- B. Painting and protective coating of metalwork and fabricated items shall, unless otherwise specified herein, be performed in accordance with the requirements of Section 09900 entitled "Painting."

#### 1.03 REFERENCE SPECIFICATIONS, CODES, AND STANDARDS

- A. Specifications, codes and standards shall be as specified in Section 05500 entitled "Metal Fabrications" and as referred to herein.

#### 1.04 SUBMITTALS

- A. Submit the following in accordance with Section 01300 entitled "Submittals":
  - 1. Complete fabrication and erection drawings of all gratings, floor plates, access hatches and access doors specified herein.
  - 2. Other submittals as required in accordance with Section 05500 entitled "Metal Fabrications".

### PART 2 -- PRODUCTS

#### 2.01 METAL MATERIALS

- A. Metal materials used for gratings, floor plates and hatches shall conform to Section 05010 entitled "Metal Materials", unless noted otherwise.

#### 2.02 METAL FASTENING

- A. All welds and fasteners used for gratings, floor plates and hatches shall conform to Section 05050 entitled "Metal Fastening", unless noted otherwise.

#### 2.03 GRATING

- A. General: Grating, including support frames, fastenings, and all necessary appurtenances for a complete installation shall be furnished as indicated on the Drawings.

1. All exposed bearing ends of grating shall be enclosed in a perimeter band of the same dimensions and materials as the main bars, including ends at all cutouts.
2. Grating shall be fabricated into easily removable sections and shall be fastened at each corner and as required with fasteners provided by the grating manufacturer. No section of grating shall weigh in excess of 50 lbs. No fasteners shall be permitted to project above the walking surface.
3. Gratings shall be designed for a loading of 150 psf unless a depth is required by the Drawings. Minimum grating depth shall be 1-1/2 inches. Deflection shall not exceed L/240 or 1/4-inch.

#### B. Aluminum Grating

1. Aluminum grating shall be of I-Bar type with cross bars at 2 inches on center and shall consist of extruded bearing bars positioned and locked by crossbars. All supports, cross members, etc. shall be aluminum. Plank clips for grating holddowns or other required attachments shall be aluminum or stainless steel. Bolts shall be stainless steel.
2. Grating shall be aluminum swage locked "I-Bar" Type IF, as manufactured by IKG Borden or equal.
3. Grating shall be provided with a mill finish.

#### C. Aluminum Plank Grating

1. Aluminum plank grating shall be unpunched, consisting of 6-inch wide extruded sections, heavy duty type with 6 ribs and plain sides, fabricated in standard sections as manufactured by Ohio Gratings, McNichols, IKG Borden, or approved equal. All planks shall be provided with extruded grating frame cast in concrete.
2. Grating panels shall be made from 6-inch wide extruded sections and banded to form standard panel widths.
3. Removal sections shall be edge banded in sections and provided with stainless steel flush mounted lift handles with necessary plank reinforcing and holdown anchors.
4. Hinged sections shall be shop fabricated ready for field installation. Panels shall be edge banded with a continuous hinge, flush mounted lifting handles (1 section minimum), stainless steel bolts and hardware. Grating frame shall be provided with removable temporary braces to maintain the required opening width during casting. Provide necessary grating reinforcing for lift handles, hinge connections, holdown anchors, etc.
5. Grating shall be provided with a mill finish.

#### D. Galvanized Steel Grating

1. Galvanized Steel grating shall be custom welded heavy duty steel grating per

ANSI/NAMM MBG 532-000. Minimum bearing bar size shall be 2-1/4" x 1/4". All supports, cross members, etc. shall be galvanized steel. Plank clips for grating hold downs shall be stainless steel. Bolts shall be galvanized steel.

2. All openings shall be banded.
3. Galvanizing shall be in accordance to Section 05035, Galvanizing.
4. Main bearing bars shall conform to ASTM A36. Cross bars shall be flush with the top of the grating.
5. Grating span shall be 36 inches maximum and shall satisfy AASHTO loading for H-20 truck.
6. Grating shall be manufactured by IKG Borden Industries, Leeds, AL.

#### 2.04 CHECKERED PLATES

- A. Checkered plates shall be aluminum alloy 6061-T6, or galvanized steel as indicated on the Drawings. Aluminum checkered plates shall be provided in mill finish, except when otherwise indicated on the Drawings. Checkered plates shall be designed for a live load of 150 pounds per square foot of the gross projected area. The allowable deflection under the above loadings shall be L/240 but not more than 1/4-inch. Minimum thickness shall be 3/8-inch, unless otherwise noted on the Drawings.
- B. Checkered plates shall be standard pattern non-slip of the thickness and sizes on the Drawings. Stiffener angles shall be provided as required to meet the load requirements specified above. All checkered plate sections shall be cut that no one section shall weigh more than 100 pounds.
- C. Flush type lifting handles and hinges and neoprene seals for airtight construction shall be provided where shown on the Drawings.

#### 2.05 ACCESS HATCHES

##### A. General

1. Door opening sizes, number and direction of swing of door leaves, and locations shall be as shown on the Drawings. The Drawings show the clear opening requirements.
2. All doors shall be aluminum (mill finish) unless otherwise noted. All doors in locations subject to direct vehicular traffic shall be galvanized steel designed for H-20 live loads.
3. Openings larger than 42 inches in either direction shall have double leaf doors.
4. Doors shall be designed for flush mounting and for easy opening from both inside and outside.



5. All doors shall be provided with an automatic hold-open arm with release handle.
6. Double leaf doors shall be provided with Type 316 stainless steel safety chains to go across the open sides of the door, when in the open position. Brackets shall be provided on the underside of the doors to hold the safety bars when not in use.
7. All hardware, including but not limited to, all parts of the latch and lifting mechanism assemblies, hold open arms and guides, brackets, hinges, springs, pins, and fasteners shall be Type 316 stainless steel.
8. Cylinder locks with keyway protected by a cover plug shall be provided with all hatches.
9. Door leafs in areas not subject to vehicular traffic shall be 1/4-inch aluminum diamond plate, minimum, stiffened and designed for 300 psf.
10. Door frames shall be trough-type or angle-type as indicated on the Drawings and equipped with a built-in neoprene cushion. On trough-type frames, the drainpipe shall be provided by the CONTRACTOR and shall extend to the nearest point of discharge acceptable to the ENGINEER.
11. Access hatches shall be model indicated on the Drawings by The Bilco Company or equal.
12. Hatches shall be guaranteed against defects for a period of five years.

## PART 3 -- EXECUTION

### 3.01 FABRICATION

- A. All measurements and dimensions shall be based on field conditions and shall be verified by the CONTRACTOR prior to fabrication. Such verification shall include coordination with adjoining work. Fabrication shall begin only after such field measurements.
- B. All fabricated work shall be shop fitted together as much as practicable and delivered to the field, complete and ready for erection, unless sections have to be removable. All miscellaneous items such as stiffeners, fillets, connections, brackets, and other details necessary for a complete installation shall be provided.
- C. All work shall be fabricated and installed in a manner that will provide for expansion and contraction, prevent shearing of bolts, screws, and other fastenings, ensure rigidity, and provide a close fit of sections.
- D. Finished members shall conform to the lines, angles, and curves shown on the Drawings and be free from distortions of any kind.
- E. All shearings shall be neat and accurate, with parts exposed to view neatly finished. Flame cutting is allowed only when performed utilizing a machine.

- F. All shop connections shall be welded unless otherwise indicated on the Drawings or specified herein. Bolts and welds shall conform to Section 05050 entitled "Metal Fastening". All fastenings shall be concealed where practicable.

### 3.02 INSTALLATION

- A. Assembly and installation of fabricate system components shall be performed in strict accordance with manufacturer's recommendations.
- B. All gratings, access hatches, and access doors shall be erected square, plumb and true, accurately fitted, adequately anchored in place and set at proper elevations and positions.

- END OF SECTION -

**DIVISION 6 – WOOD AND PLASTICS**

SECTION 06620 – SCUM BAFFLES AND WEIR PLATES  
(ALTERNATE BID ITEM)

PART 1 -- GENERAL

1.01 THE REQUIREMENT

- A. As part of the Base Bid, the CONTRACTOR shall perform all work necessary to bring Clarifier No. 3 to a fully operable system, including removal and re-installation of existing equipment, per the Contract Documents. At the CITY's option under an Alternate Bid Item, the CONTRACTOR shall furnish and install scum baffles and weir plates as shown on the Contract Drawings, shop drawings and specified herein.

1.02 RELATED WORK SPECIFIED ELSEWHERE

- A. Precast Concrete
- B. Metal Fabrications
- C. Sealants and Caulking

1.03 REFERENCE SPECIFICATIONS, CODES, AND STANDARDS

A. Commercial Standards

- |     |            |  |
|-----|------------|--|
| 1.  | ASTM A193  | Specification for Carbon Alloy-Steel and Stainless Steel Bolting Materials for High-Temperature Service                                      |
| 2.  | ASTM A194  | Specification for Carbon Alloy-Steel Nuts for Bolts for High-Pressure and High Temperature Service   |
| 3.  | ASTM C581  | Practice for Determining Chemical Resistance of Thermosetting Resins Used in Glass Fiber Reinforcing Structures, Intended for Liquid Service |
| 4.  | ASTM D256  | Test Methods for Impact Resistance of Plastics and Electrical Insulating Materials   |
| 5.  | ASTM D570  | Test Method for Water Absorption of Plastics   |
| 6.  | ASTM D638  | Test Method for Tensile Properties of Plastics   |
| 7.  | ASTM D696  | Test Method for Coefficient of Linear Thermal Expansion of Plastics  |
| 8.  | ASTM D790  | Test Methods for Flexural Properties of Unreinforced and Reinforced Plastics and Electrical Insulating Materials                             |
| 9.  | ASTM D2563 | Recommended Practice for Classifying Visual Defects in Glass-Reinforced Plastic Laminate Parts   |
| 10. | ASTM D2583 | Test Method for Indentation Hardness of Rigid Plastics by Means of a Barcol Impressor  |

#### 1.04 GENERAL INFORMATION AND DESCRIPTION

- A. Weir plates shall be 90° V-notch type, 4-inches center to center for Clarifier No. 3, as indicated on the Drawings. Serpentine weirs, complete with supports, etc., shall be provided in the corners of Clarifier No. 3 as indicated on the Drawings. Scum baffles shall be 12 inches high with a 24 inch high section located at each scum box.

#### 1.05 SUBMITTALS

- A. The CONTRACTOR shall submit shop drawings, detailed installation drawings and other information to the ENGINEER for review in accordance with the Section entitled "Submittals".
- B. Submittals shall include: FRP manufacturer; resins used; assembly and erection details; sizes; profiles; fasteners and their proper torque load to be applied; supports; anchors; finishes; colors; clearances; and connections to other work.
- C. Submit two (2) samples of each type of baffle and weir plate to the ENGINEER.

#### 1.06 MANUFACTURERS

- A. The following list of manufacturer products that are acceptable for this section, subject to conformance with the specified requirements, are: Warminster Fiberglass, Plasti-Fab A Division of Ershigs, or equal. All fiberglass baffles and weir plates shall be the product of one manufacturer.

### PART 2 -- PRODUCTS

#### 2.01 MATERIALS

- A. All weir plates, scum baffle plates, butt plates, cover plates, washers and scum baffle supports shall be fiberglass reinforced polyester plastic molded by the matched-die method to product uniform, smooth surfaces. A "low profile" resin system shall be used to ensure that all surfaces shall be smooth, resin rich, free of voids and porosity, without dry spots, exposed glass, crazes or unreinforced areas to provide increased corrosion and weather resistance. All edges shall be sealed in the mold. Resin shall be Isophthalic Polyester Fire Retardant (ISOFR) suitable for use in submerged waste treatment applications.
- B. Laminate shall contain a glass content of 30±2 percent using Type "E" glass with chrome or silane finish. Powdered reinforcements shall consist of 47.5 + 1 percent of resin mixture. Final laminate thickness shall be within ±10 percent of the nominal specified thickness. Ultraviolet absorbers shall be added to the resin to prevent deterioration from sunlight. Where weir plates are of nonstandard length or nonstandard mounting hole configuration, such machined or cut edges shall be resin sealed with seal mix.
- C. All items shall be manufactured in accordance with ASTM D2996 and ASTM D3917. The manufacturer shall maintain a continuous quality control program and shall, upon

request, furnish the ENGINEER with certified test reports consisting of physical tests of samples to verify that the laminate has the following minimum physical properties:

<u>Requirement</u>	<u>Minimum Results</u>	<u>Test Method</u>
Tensile Strength (psi)	14,000	ASTM D638
Flexural Strength (psi)	25,000	ASTM D790
Flexural Modulus (psi)	1.0 x 10 <sup>6</sup>	ASTM D790
Impact, Notched, Izod, (foot pound per inch)	15.0	ASTM D256
Barcol Hardness	Minimum, Avg. 40	ASTM D2583
Water absorption, (%/24 hours)	0.1	ASTM D570
Average coefficient of thermal expansion (inch per inch per °F)	10.5 x 10 <sup>-6</sup>	ASTM D696

- D. Procedure used in determining the above properties shall be in accordance with the ASTM Standards, Part 35, using the method designated above. Hardness tests shall be made on the resin rich surfaces of the test samples. Test coupons shall be prepared in accordance with the appropriate ASTM test method.
- E. When it is necessary to adjust lengths of weir plates or scum baffle plates so that they are nonstandard, all machined or cut edges thus exposed shall be polyester resin sealed.

## 2.02 WEIR PLATES

- A. Weir plates shall be ¼-inch nominal thickness and blue-green in color. Each weir plate will be 11-7/8 inches high with notches 2-7/8 inches deep x 90° on 4-inch centers for Clarifier No. 3. Each weir plate will be provided with 2-1/2 square mounting holes at 12 inches on center to provide a minimum 2-inch vertical or horizontal adjustment. Weir plates shall be secured to the wall with ½-inch diameter 316 stainless steel anchor bolts and 5-inch minimum diameter fiberglass reinforced plastic washers to prevent short circuiting. Ends of weir plates shall be secured with 6-inch x 11-7/8-inch high lap plates, fabricated to the specific shape of the concrete troughs (launders), arranged to allow for horizontal expansion. All stainless steel anchor bolts and plastic washers required for installation shall be furnished by the FRP Supplier.

## 2.03 SCUM BAFFLE PLATES

- A. Scum baffle plates shall be ¼-inch nominal thickness and turquoise in color. Baffle plates will be 12 inches high and provided with mounting holes as required to attach to the support brackets. Lengths shall be made to suit the tank, but lengths shall not exceed 10 feet.
- B. Lap plates 6 inches x 12 inches shall be provided to secure the ends of the baffle plates. Type 316 stainless steel hardware shall be furnished by the FRP supplier to secure the

baffle plates to 316 SS support brackets and to lap plates. Type 316 SS anchor bolts shall be used for anchoring scum baffle supports to the wall.

- C. Scum baffle support brackets shall be made from fiberglass reinforced polyester resin and shall be installed at 36 inches on center. Brackets will be minimum 3/16-inch thick, a minimum of 4 inches wide and slotted to allow for at least 1-1/2-inch vertical and horizontal adjustment. The upper brackets shall be minimum 1/2-inch thick and "L" shaped to accommodate a brush type scum baffle cleaning system. Type 316 stainless steel anchor bolts at 36 inches on center shall be furnished by the CONTRACTOR.

### PART 3 -- EXECUTION

#### 3.01 INSTALLATION

- A. Weirs, baffles and troughs shall be installed under this Contract in full accordance with the manufacturer's recommendations and shop drawings by mechanics skilled in the installation of this type of work and under the supervision of the manufacturer's representative.
- B. Joints between weir plates and concrete and butting weir plates shall be reasonably tight. The CONTRACTOR shall caulk all joints as directed by the ENGINEER where leakage is excessive, with a sealant material as specified in the Section entitled, "Sealants and Caulking".
- C. Bolt protrusions shall be minimized. Bolts/studs which attach the weir scum baffle shall not protrude more than 1/4-inch past the nuts.
- D. The horizontal distance between the scum baffle and the effluent troughs shall be a minimum of eight (8) inches.

- END OF SECTION -

SECTION 06650 – DENSITY CURRENT BAFFLES  
(ALTERNATE BID ITEM)

PART 1 - GENERAL

1.01 THE REQUIREMENT

- A. As part of the Base Bid, the CONTRACTOR shall perform all work necessary to bring Clarifier No. 3 to a fully operable system, including removal and re-installation of existing equipment, per the Contract Documents. At the CITY's option under an Alternate Bid Item, the CONTRACTOR shall furnish and install fiberglass reinforced plastic density current baffles along with all support brackets, fasteners, anchors and other incidental work as shown on the Contract Drawings for Clarifier No. 3.
- B. The final installation shall be complete in all respects and the CONTRACTOR shall be responsible for minor details and any necessary special construction not specifically included in the drawings or specifications.

1.02 QUALITY ASSURANCE

- A. General. The CONTRACTOR shall furnish certified test reports of the physical and mechanical properties of the product. Each panel shall have the minimum physical properties specified herein. Flexural properties shall be measured with the resin-rich upper surface in compression. Hardness tests shall be made on the resin-rich upper surface.
- B. Standards
  - 1. ASTM – American Society for Testing Materials

<b>Method</b>	<b>Test</b>	<b>Minimum Value</b>
ASTM D-638	Tensile Strength	5,000 psi
ASTM D-790	Flexural Strength	16,000 psi
ASTM D-790	Modulus of Elasticity	800,000 psi

- 2. Rockwell – Rockwell Laboratories

<b>Method</b>	<b>Test</b>	<b>Minimum Value</b>
Rockwell	Hardness	R15T 65



- C. All fiberglass items of the same type provided shall be the products of a single manufacturer for compatibility.
- D. The equipment manufacturer shall furnish a list of five (5) installations of similar size that have been in continuous operation for a minimum of three (3) years.

#### 1.03 SUBMITTALS

- A. Submit manufacturer's technical data and application instructions.
- B. In accordance with Section entitled "Submittals", shop drawings shall show dimensional layouts, materials of construction, bill of materials, bolt and anchor locations, fittings and accessories and shall be based on field measurements by the CONTRACTOR as he deems necessary to ensure a conflict and trouble-free installation. Fabrication shall be in accordance with the shop drawings.
- C. The manufacturer shall submit calculations confirming that the baffle is capable of withstanding the unbalanced force acting from underneath the baffle, which is assumed equal to the full buoyancy. The calculation shall be prepared, signed, dated and sealed by a registered professional engineer.
- D. The baffle manufacturer shall warrant that all materials furnished by him shall be free of defects in materials and workmanship for a period of five (5) years from the date of acceptance.

#### 1.04 JOB CONDITIONS

- A. Coordinate all work with other trades to prevent delays, errors and/or omissions.

#### 1.05 DELIVERY, STORAGE AND HANDLING

- A. The CONTRACTOR shall store materials indoors and protect from construction traffic and damage.

### PART 2 - PRODUCTS

#### 2.01 DENSITY CURRENT BAFFLES

- A. The density current baffle system shall consist of a series of baffle panels that are attached to the wall of the clarifier to form an inclined, shelf-like surface around the inner periphery of the tank. Panels shall be designed to fit between trough supports. Each panel shall be molded of corrosion-resistant, uv-treated fiberglass. The panel shall be a maximum of eight feet in length and shall be curved to follow the curvature of the clarifier tank. Each panel shall be 68 inches wide and inclined at a 45-degree angle from the tank wall. The panels shall be designed such that adjacent panels fit together without overlapping or cutting, and the completed baffle, when installed, has a well-engineered and professional appearance.
- B. Provision shall be made to attach the panels to the clarifier wall and support them at the proper angle using a triangular panel bracket. The panel bracket shall be molded as an

integral part of each panel, forming a baffle module, or separate panels and brackets may be supplied. If the panel and bracket are molded as an integral unit with adequate stiffeners, only one bracket is required per panel. A specially formed "free-end" bracket shall be provided to support the free-end of the panel at the trough supports or where the run of panels is interrupted by an obstruction. No modifications to the panels shall be made without the written approval of the ENGINEER.

- C. If separate panels and brackets are supplied, the panels shall be molded of fiberglass and shall meet the specifications of this section. The brackets shall be fabricated of 3"x3"x1/4" Type 304 stainless steel angle and shall be triangular in shape, with the corners welded. Brackets shall be installed at a maximum spacing of four (4) feet. The panels shall be fastened to the brackets with stainless steel nuts, bolts and lock washers every 8 inches.
- D. A method of interconnecting adjacent panels shall be provided such that the entire assembly forms a rigid structure capable of supporting its own weight plus wind loads in the event the tank is out of service. The baffle shall also be designed to withstand a buoyant force load equal to the weight of the water displaced from the volume beneath the baffle and shall resist flotation in the event gas builds beneath the panel. The angled working surface of each baffle shall be sufficient in pitch and width to divert the flow and to create a self-cleaning action of the baffle itself. Provision shall also be made to vent gasses that may form beneath the baffle through the installation of vents located in the panel. Vents shall be formed in at the time of panel fabrication.

## 2.02 COMPONENTS

- A. Each baffle panel shall be molded of fiberglass-reinforced plastic. The resins and fiberglass reinforcing material shall be compatible with the environmental conditions and structural requirements.
- B. The resin shall be an isophthalic polyester resin with corrosion-resistant properties, 33-402 resin or equivalent, suitable for use in submerged waste treatment applications. The resin shall not contain fillers except as required for viscosity control. For viscosity control, a thixotropic agent up to 5 percent by weight may be added to the resin. The resin shall be treated to provide ultraviolet suppression.
- C. Glass reinforcement shall consist of chemically bonded surfacing mat and chopped strand roving. Surfacing mat shall be Type C veil. The glass reinforcement shall be 357-211 PLN CTC chopped strand roving or equivalent. The glass content of the finished laminate shall not be less than 30 percent by weight. The nominal thickness of each baffle panel shall be a minimum of 1/4-inch thick with resin rich surfaces and edges to prevent migration of moisture and fiber "blooming". The baffle shall be black in color.
- D. The upper surface of each panel shall be mold smooth and no glass fibers shall be exposed. Laminations shall be dense and free of voids, dry spots, cracks or crazes. The upper surface of the baffle shall be reinforced with one layer of surfacing veil followed by 2 ounces or more of chopped strand roving. No other glass product is permitted between these layers. All factory-trimmed edges shall be "hot coated" with resin to prevent wicking.

- E. When it is necessary to adjust lengths of baffle panels so that they are nonstandard, all machined or cut edges thus exposed shall be polyester resin sealed.
- F. The density current baffle system shall be as supplied by, Warminster Fiberglass Company, Plasti-Fab A Division of Ershigs, or equal.

### PART 3 - EXECUTION

#### 3.01 INSTALLATION

- A. The CONTRACTOR shall field verify existing dimensions and install the baffle in accordance with the contract drawings, approved shop drawings and manufacturer's recommendations. Mounting holes shall be factory drilled. Field cutting of baffle panels will be allowed to complete the structure and accommodate in-tank obstructions. All field cut or drilled edges shall be coated per the manufacturer's recommendations to prevent fiber blooming or fraying. All of the fasteners required for installation shall be supplied by the baffle manufacturer. The baffle panels shall be attached to the wall using 1/2-inch x 3-3/4-inch concrete expansion anchors with neoprene-backed fender washers, lock washers and hex nuts. Adjacent baffle panels are fastened together with 1/4-inch bolts, 2 washers, lock washer and hex nut. All of the installation fasteners shall be 316 stainless steel.
- B. The density current baffle shall extend completely around the tank and shall be level, rigid and free of sway that could work anchors loose or cause undue wear.

- END OF SECTION -

**DIVISION 7 – THERMAL AND MOISTURE PROTECTION**

## SECTION 07920 – JOINT FILLERS, SEALANTS AND CAULKING

### PART 1 – GENERAL

#### 1.01 THE REQUIREMENT

A. Furnish labor, materials, equipment and appliances required for the complete execution of Work shown on the Drawings and specified herein. The required applications of sealants and caulking include, but are not necessarily limited to, the following general locations:

1. Masonry joints, exterior and interior.
2. Joints at penetrations of walls, decks by piping, doors, windows, louvers and other services and equipment.
3. Joints between items of equipment and other construction.
4. Joints in concrete.

#### 1.02 RELATED WORK SPECIFIED ELSEWHERE

- A. Division 3 – Concrete
- B. Division 6 – Woods and Plastics
- C. Division 11 – Equipment

#### 1.03 REFERENCE SPECIFICATIONS, CODES AND STANDARDS

A. Without limiting the generality of the other requirements of the specifications, all work herein shall conform to the applicable requirements of the following documents. All referenced specifications, codes, and standards refer to the most current issue available at the time of Bid.

1. ASTM C-920 – Elastomeric Joint Sealants
2. ASTM D-1056 – Flexible Cellular Materials – Sponge or Expanded Rubber
3. SWRI – Sealant and Caulking Guide Specification

#### 1.04 SUBMITTALS

- A. In accordance with the procedures and requirements set forth in the Section entitled “Submittals”, submit the following:
  1. Manufacturers literature and installation instructions. Label each product submitted with Type as indicated in paragraph 2.01 A.

2. Color samples of each type of sealant.

B. Submit a two year guarantee on sealant type caulking work against joint failure. Joint failure is defined as leaks of air or water; evidence of loss of cohesion; fading of sealant material; migration of sealant; evidence of loss of adhesion between sealant and joint edge.

#### 1.05 QUALITY ASSURANCE

A. Applicator shall be a company specializing in the installation of sealants with a minimum of five years of experience.

#### 1.06 DELIVERY, STORAGE AND HANDLING

A. Deliver materials in unopened labeled packages.

B. Store materials in location protected from freezing or damages.

C. Reject and remove from the site materials within broken or damaged packaging.

### PART 2 – PRODUCTS

#### 2.01 MATERIALS

##### A. Sealants

1. Type 1: Multi-component, non-sag, low-modulus polyurethane rubber sealant meeting ASTM C-920, Type M, Grade NS, Class 25, use NT, M, A, and O. Capable of withstanding 50% in extension or compression such as Sikaflex-2C NS/SL, Sika Corporation, or Sonolastic NP-2, Sonneborn, DynaTrol II by Pecora Corporation, or approved equal.
2. Type 2: Single component polyurethane sealant meeting ASTM C-920, Type S, Grade NS, Class 25, Use NT, M, A, and O. Capable of withstanding 25% in extension or compression such as Sikaflex 1A by Sika Corporation, DynaTrol 1-XL by Pecora Corporation, Sonolastic NP-1 by Master Builders Solutions, or approved equal.
3. Type 3: Single component, low-modulus moisture curing silicone meeting ASTM C-920, Type S, Grade NS, Class 25, Use NT, M, G, and A. Capable of withstanding 50% extension and compression. Pecora 890 by Pecora Corporation, Sonolastic Omni Seal by Master Builders Solutions, or approved equal.
4. Type 4: Single component, mildew resistant, moisture-curing silicone meeting ASTM C-920, Type S, Grade NS, Class 25, Use NT, M, G, and A. Pecora 898 by Pecora Corporation, Sonolastic Omni Plus by Master Builders Solutions, or approved equal.

5. Type 5: Single component, acrylic latex meeting ASTM C-834. AC-20+ Silicone by Pecora Corporation, Sonneborn Sonolac by Master Builders Solutions, or approved equal.
  6. Type 6: High grade butyl sealant meeting Federal Specification TT-S-00-1657. BC-158 by Pecora Corporation or approved equal.
  7. Type 7: Multi-component chemical resistant polysulfide sealant conforming to ASTM C-920, Type M, Grade NS, Class 25 such as Deck-O-Seal by W.R. Meadows, Tammsflex by DuraJoint Concrete Accessories, Synthacalk GC2+ by Pecora Corporation, or approved equal.
  8. Type 8: Nonsag, Multi Component, traffic grade polyurethane sealant meeting ASTM C920, Type M, Grade NS, Class 25, use T, M, A, and O. DynaTread by Pecora Corporation, Sonolastic Ultra by Master Builders Solutions, or approved equal.
- B. Primer: Non-staining primer recommended by sealant manufacturer for the substrates on this project.
- C. Backer Rod: Closed cell foam, nonreactive with caulking materials, non-oily, and approved by the sealant manufacturer. Minimum density shall be 2.00 pounds per cubic foot. Use no asphalt or bitumen-impregnated fiber with sealants.
- D. Joint Cleaner: Recommended by sealant or caulking compound manufacturer.
- E. Bond breaker: Either polyethylene film or plastic tape as recommended by the sealant manufacturer.
- F. Color: Where manufacturer's standard colors do not closely match materials being sealed, provide a custom color.

### PART 3 – EXECUTION

#### 3.01 QUALITY CONTROL

- A. Coordinate work with details shown on approved shop drawings prepared by other trades.
- B. Verify conditions in the field.
- C. Schedule work to follow closely the installation of other trades.
- D. Apply sealants and related items in temperatures and dry conditions recommended by the manufacturers.
- E. Do not paint sealant, unless recommended by sealant and paint manufacturer.

### 3.02 PREPARATION

- A. Protect finished surfaces adjoining by using masking tape or other suitable materials.
- B. Clean and prime joints before starting any caulking or sealing work.
- C. Thoroughly clean joints and spaces of mortar and other foreign materials. Cleaning agent shall be Xylol or similar non-contaminating solvent to remove any film from metal surfaces. Masonry or concrete surfaces shall be brushed or air jet cleaned.
- D. Joint Requirements
  - 1. All joints and spaces to be sealed in exterior work shall be less than 1/2-inch deep and not less than 1/4 inch wide. If joints in masonry are less than that specified herein, the mortar shall be cut out to the required width and depth. All joints and spaces to receive sealant shall be completely prepared and thoroughly dry before installation of sealant.
  - 2. Unless otherwise specified, joints and spaces which are open to a depth of 1/2 inch or greater shall be solidly filled with back-up material to within 1/4 inch of the surface. Back-up material shall be packed tightly and made continuous throughout the length of the joints. Bond breaker shall be applied as required. If joints are less than 1/4-inch deep, the back-up material may be omitted, a bond breaker substituted and the joint completely filled with sealant. The back-up material shall not project beyond the 1/4-inch depth of the open space in any joint. The following width-to-depth ratio table shall be adhered to, unless otherwise recommended by manufacturer.

Joint Width	Sealant Depth	
	Minimum	Maximum
1/4 inch	1/4 inch	1/4 inch
Over 1/4 inch to 1/2 inch	1/4 inch	Equal to width
Over 1/2 inch to 1 inch	1/2 inch	Equal to width
Over 1 inch to 2 inches	1/2 inch	1/2 of width

### 3.03 APPLICATION

- A. Exercise care before, during, and after installation so as not to damage any material by tearing or puncturing. All finished work shall be approved before covering with any other material or construction.
- B. Apply sealant by an approved type of gun except where the use of a gun is not practicable, suitable hand tools shall be used. Avoid applying the compound to any



surface outside of the joints or spaces to be sealed. Mask areas where required to prevent overlapping of sealant.

- C. All joints shall be waterproof and weathertight.
- D. Point sealed joints to make a slightly concave joint, the edges of which are flush with the surrounding surfaces. Exposed joints in the interior side of the door and other frames shall be neatly pointed flush or to match adjacent jointing work.
- E. Adjacent materials which have been soiled shall be cleaned immediately and the work left in neat and clean condition.
- F. Comply with sealant manufacturer's written instructions except where more stringent requirements are shown or specified and except where manufacturer's technical representative directs otherwise.

### 3.04 ADJUSTMENT AND CLEANING

- A. Remove misplaced sealant compounds promptly using methods and materials recommended by the manufacturer, as the work progresses.
- B. Allow sealants to cure and remove protective edging, of doors, louvers, saddles windows etc. as directed by the Engineer.

### 3.05 SCHEDULE

**Schedule of Sealants**

<b>Application</b>	<b>Sealant</b>	<b>Color</b>
Vertical and horizontal expansion and construction joints in concrete structures unless noted otherwise herein or on Drawings.	Type 1	To closely match adjacent surfaces or mortar and as selected by the Owner.
Vertical and horizontal joints bordered on both sides by masonry, precast concrete, natural stone or other porous building material, unless noted otherwise herein or on Drawings.	Type 2	To closely match adjacent surfaces or mortar and as selected by the Owner.
Vertical and horizontal joints bordered on both sides by painted metals, anodized aluminum, mill finished aluminum, PVC, glass or other non-porous building material.	Type 3	To closely match adjacent surfaces and as selected by the Owner.
Masonry expansion and control joints less than 1¼" wide.	Type 2	To closely match adjacent surfaces and as selected by the Owner.
Masonry expansion and control joints equal or greater than 1¼ inches wide and not to exceed 2".	Type 1	To closely match adjacent surfaces and as selected by the Owner.
Interior – wood trim and finish joints.	Type 5	Color to be selected by Owner

### Schedule of Sealants

Application	Sealant	Color
Sanitary areas, joints in ceramic tile, around plumbing fixtures, countertops, and back splashes. <sup>1</sup>	Type 4	To closely match adjacent surfaces and as selected by the Owner.
Perimeter sealing of doors, windows, louvers, piping, ducts, and electrical conduit. <sup>2</sup>	Type 2 OR Type 3	To closely match adjacent surfaces and as selected by the Owner.
Below thresholds.	Type 6	Manufacturer's standard
Submerged in liquids. <sup>3,4</sup>	Type 1	Manufacturer's standard
Submerged in liquids with high concentration of chlorine (> 2 ppm) or wastewater.	Type 7	Manufacturer's standard
Horizontal Joints exposed to vehicular or pedestrian traffic.	Type 8	To closely match adjacent surfaces.
Other joints indicated on the drawings or customarily sealed but not listed.	Type recommended by manufacturer	To closely match adjacent surfaces and as selected by the Owner.

<sup>1</sup> Sealant shall be as recommended by manufacturer.

<sup>2</sup> Provide UL approved sealants for penetrations thru fire-rated walls and as specified in Section 07270.

<sup>3</sup> Sealants which will come in contact with potable water shall meet the requirements of NSF 61.

<sup>4</sup> Where sealant will be immersed in liquid chemicals verify compatibility prior to installation of sealant.

END OF SECTION

**DIVISION 9 – FINISHES**

## SECTION 09900 - PAINTING

### PART 1 -- GENERAL

#### 1.01 THE REQUIREMENT

- A. The CONTRACTOR shall furnish all labor, tools, materials, supervision and equipment necessary to do all the work specified herein and as required for a complete installation, including surface preparation, priming and painting of CONTRACTOR furnished equipment, materials, and structures.

#### 1.02 GENERAL INFORMATION AND DESCRIPTION

- A. The term "paint," as used herein, includes emulsions, enamels, paints, stains, varnishes, sealers, cement filler, cement-latex filler and other coatings, whether used as prime, intermediate, or finish coats.
- B. All paint for concrete and metal surfaces shall be especially adapted for use around wastewater treatment plants and shall be applied in conformance with the manufacturer's published specifications.
- C. All paint for final coats shall be fume resistant, compounded with pigments suitable for exposure to sewage gases, especially to hydrogen sulfide and to carbon dioxide. Pigments shall be materials which do not tend to darken, discolor, or fade due to the action of sewage gases. If a paint manufacturer proposes use of paint which is not designated "fume resistant" in its literature, it shall furnish full information concerning the pigments used in this paint.
- D. Provide primers and intermediate coats produced by same manufacturer as finish coat. Use only thinners approved by paint manufacturer, and only within manufacturer's recommended limits
- E. Coatings used in conjunction with potable water supply systems shall have U.S. Environmental Protection Agency (EPA) and FDA approval for use with potable water and shall not impart a taste or odor to the water.
- F. All building, facilities, structures, and appurtenances, as indicated on the Drawings and as specified herein, shall be painted with not less than one shop coat and two field coats, or one prime coat and two finish coats of the appropriate paint. Items to be painted include, but are not limited to, exterior and interior concrete, structural steel, miscellaneous metals, steel and aluminum doors and frames, concrete block, ductwork, sluice gates, operators, pipe fittings, valves, mechanical equipment, motors, conduit, and all other work which is obviously required to be painted unless otherwise specified.
- G. Baked-on enamel finishes and items with standard shop finishes such as graphic panels, electrical equipment, toilet partitions, lockers, instrumentation, etc., shall not be field painted unless the finish is damaged during shipment or installation. Aluminum, stainless steel, fiberglass and bronze work shall not be painted unless color coding and marking is required or otherwise specified. A list of surfaces not to be coated is included in Article 1.11 of this Section.

- H. Ensure compatibility of total paint system for each substrate. Test shop primed equipment delivered to the site for compatibility with final paint system. Provide an acceptable barrier coat or totally remove shop applied paint system when incompatible with system specified and repaint with specified paint system.
- I. The CONTRACTOR shall obtain all permits, licenses and inspections and shall comply with all laws, codes, ordinances, rules and regulations promulgated by authorities having jurisdiction which may bear on the work. This compliance will include Federal Public Law 91-596 more commonly known as the "Occupational Safety and Health Act of 1970".

1.03 RELATED WORK SPECIFIED ELSEWHERE

- A. Section 01010 – Summary of Work
- B. Section 11232 – Final Clarifier Mechanism (ALTERNATE BID ITEMS)

1.04 REFERENCE SPECIFICATION, CODES AND STANDARDS

- A. Without limiting the generality of these specifications the Work shall conform to the applicable requirements of the following documents:
  - 1. SSPC - The Society for Protective Coatings Standards
    - a. SSPC-Vis 1 Pictorial Surface Preparation Standards for Painting Steel Structures
    - b. SSPC-SP2 Hand Tool Cleaning
    - c. SSPC-SP3 Power Tool Cleaning
    - d. SSPC-SP5 (NACE No. 1) White Metal Blast Cleaning
    - e. SSPC-SP6 (NACE No. 3) Commercial Blast Cleaning
    - f. SSPC-SP10 (NACE No. 2) Near-White Metal Blast
    - g. SSPC-SP13 (NACE No. 6) Surface Preparation of Concrete
  - 2. NACE - National Association of Corrosion Engineers
  - 3. ASTM D1737 - Test Method for Elongation of Attached Organic Coatings with Cylindrical Mandrel Apparatus
  - 4. ASTM B117 - Method of Salt Spray (Fog) Testing
  - 5. ASTM D4060 - Test Method for Abrasion Resistance of Organic Coating by the Taber Abraser

6. ASTM D3359 - Method for Measuring Adhesion by Tape Test

1.05 MANUFACTURERS

- A. All painting materials shall be as manufactured by Tnemec or Carboline, unless otherwise stated in the Contract Documents.

1.06 SUBMITTALS

- A. The CONTRACTOR shall submit paint manufacturer's data sheets, application instructions, and samples of each finish and color to the ENGINEER for review, before any work is started in accordance with Section 01300 entitled, "Submittals."
- B. Submitted samples of each finish and color shall be prepared in a step-down format so that the area of each sample indicates the appearance of the various coats. For example, where a three-coat system is specified, the sample shall be divided into three areas indicating one coat only, two coats and all three coats. The ENGINEER will provide written authorization constituting a standard, as to color and finish only, for each coating system.
- C. The CONTRACTOR shall prepare a complete schedule of surfaces to be coated and shall identify the surface preparation and paint system he proposes to use. The Paint Schedule shall be in conformance with Article 3.03 of this Section. The schedule shall contain the name of the paint manufacturer, and the name, address and telephone number of the manufacturer's representative that will inspect the Work. The schedule shall be submitted to the ENGINEER for review as soon as possible following the Notice to Proceed so that the schedule may be used to identify colors and to specify shop painting systems on order for fabricated equipment.
- D. Name and detailed qualifications of the protective coating applicator or subcontractor. Qualifications shall include, but not be limited to, five (5) references which show that the painting applicator or subcontractor has previous successful experience with the specified or comparable coating systems, a list of installations that are currently in service and documentation that applicator or subcontractor is currently a qualified applicator of the proposed coatings by the manufacturer. For crystalline waterproofing and crystalline waterproofing resurfacer, applicator or subcontractor shall also provide manufacturer's documentation that company and/or personnel are certified applicators.
- E. CERTIFICATIONS: The coating manufacturer shall submit the following certifications:
  - 1. A letter from the coating manufacturer stating that the specified material is suitable for the application.
  - 2. Inspection reports of coating manufacturer certifying that all inspections by the manufacturer as specified in 09900-1.07 showed satisfactory performance of the work by the coating applicator.
  - 3. A letter from the coating manufacturer certifying that the surface preparation has been properly completed.
  - 4. A letter from the coating manufacturer certifying that the coating system has been properly applied and acknowledging that their warranty is in effect.

5. A sample copy of the warranty to be issued after completion of the work.
6. Test reports of all testing and inspections during the work.

#### 1.07 SERVICES OF MANUFACTURER'S REPRESENTATIVE

- A. The CONTRACTOR shall purchase paint from an acceptable manufacturer. The manufacturer shall assign a representative to inspect the application of his product both in the shop and field. The manufacturer's representative shall provide an application letter with the submitted painting system that the products proposed are proper for the exposure and service. The CONTRACTOR, through the manufacturer's representative, shall submit his report to the ENGINEER at the completion of his Work identifying the products used and verifying that said products were properly applied and that the paint systems were proper for the exposure and service.
- B. Services shall also include, but not be limited to, inspecting prior coatings of paint, determination of best means of surface preparation, inspection of complete work, and re-inspection of painted work to be performed six months after the job is completed.

#### 1.08 MANUFACTURER'S INSTRUCTIONS

- A. The manufacturer's published instructions for use as a guide in specifying and applying the manufacturers proposed paint shall be submitted to the ENGINEER. Paint shall not be delivered to the job before acceptance of the manufacturer's instructions is given by the ENGINEER.
- B. A manufacturer's paint will not be considered for use unless that manufacturer's published instructions meets the following requirements:
  1. The instructions must have been written and published by the manufacturer for the purpose and with the intent of giving complete instruction for the use and application of the proposed paint in the locality and for the conditions for which the paint is specified or shown to be applied under this Contract.
  2. All limitations, precautions, and requirements that may adversely affect the paint; that may cause unsatisfactory results after the painting application; or that may cause the paint not to serve the purpose for which it was intended; that is, to protect the covered material from corrosion, shall be clearly and completely stated in the instructions. These limitations and requirements shall, if they exist, include, but not be limited to the following:
    - a. Methods of application
    - b. Number of coats
    - c. Thickness of each coat
    - d. Total thickness
    - e. Drying time of each coat, including primer
    - f. Primer required to be used
    - g. Primers not permitted
    - h. Use of a primer
    - i. Thinner and use of thinner

- j. Temperature and relative humidity limitations during application and after application
  - k. Time allowed between coats
  - l. Protection from sun
  - m. Physical properties of paint including solids content and ingredient analysis
  - n. Surface preparation
  - o. Touch up requirements and limitations
  - p. Return to service
- C. Concrete surfaces specified by the paint manufacturer to be acid etched shall be etched in accordance with the manufacturer's instructions. The surface shall then be thoroughly scrubbed with clean water, rinsed, and allowed to dry. The surface shall be tested with a moisture meter to determine when dry before coating. The surface shall also be tested for pH to determine the acid has been properly neutralized.

#### 1.09 QUALITY ASSURANCE

- A. The CONTRACTOR shall give the ENGINEER a minimum of three days advance notice of the start of any field surface preparation work of coating application work.
- B. All such Work shall be performed only in the presence of the ENGINEER, unless the ENGINEER has specifically allowed the performance of such Work in his absence.
- C. Review by the ENGINEER, or the waiver of review of any particular portion of the Work, shall not relieve the CONTRACTOR of his responsibility to perform the Work in accordance with these Specifications.
- D. The CONTRACTOR shall provide references of the coating applicator or subcontractor per article 1.06, D.

#### 1.10 SAFETY AND HEALTH REQUIREMENTS

- A. In accordance with requirements of OSHA Safety and Health Standards for Construction (29CFR1926) and the applicable requirements of regulatory agencies having jurisdiction, as well as manufacturer's printed instructions, appropriate technical bulletins, manuals, and material safety data sheets, the CONTRACTOR shall provide and require use of personnel protective and safety equipment for persons working in or about the project site.
- B. Respirators shall be worn by persons engaged or assisting in spray painting. The CONTRACTOR shall provide ventilating equipment and all necessary safety equipment for the protection of the workmen and the work.
- C. All paint shall comply with all requirements of the Air Pollution Regulatory Acts concerning the application and formulation of paints and coatings for an area in which the paints are applied. Specifically, paints shall be reformulated as required to meet the local, State and Federal requirements.

#### 1.11 SURFACES NOT TO BE COATED

- A. The following items shall not be coated unless otherwise noted:



- Encased piping or conduit.
- Stainless steel work.
- Clear PVC secondary containment piping.
- Galvanized checkered plate.
- Aluminum handrails, walkways, windows, louvers, grating and checkered plate.
- Flexible couplings, lubricated bearing surfaces and insulation.
- Packing glands and other adjustable parts of mechanical equipment.
- Finish hardware.
- Steel encased in concrete or masonry.
- Plastic switch plates and receptacle plates.
- Signs, nameplates, serial numbers and operating instruction labels.
- Any code-requiring labels, such as Underwriters' Laboratories and Factory Mutual, or any equipment identification, performance rating, name or nomenclature plates.
- Any moving parts of operating units, mechanical and electrical parts, such as valve and damper operators, linkages, sensing devices, motor and fan shafts, unless otherwise indicated.

#### 1.12 QUALITY WORKMANSHIP

- A. The CONTRACTOR shall be responsible for the cleanliness of his painting operations and shall use covers and masking tape to protect the work whenever such covering is necessary, or if so requested by the CITY. Any unwanted paint shall be carefully removed without damage to any finished paint or surface. If damage does occur, the entire surface, adjacent to and including the damaged area, shall be repainted without visible lapmarks and without additional cost to the CITY.
- B. Painting found defective shall be scraped or sandblasted off and repainted as the CITY may direct. Before final acceptance of the work, damaged surfaces of paint shall be cleaned and repainted as directed by the CITY.

#### 1.13 ADDITIONAL PAINT

- A. At the end of the project, the Contractor shall turn over to the Owner a one gallon can (single component material) or small kit (multi component material – minimum of one gallon yield) of each type and color of paint, primer, thinner or other coating used in the field painting. The material shall be delivered in unopened, labeled cans as it comes from the factory. The manufacturer's literature describing the materials and giving directions for their use shall be furnished in three bound copies. A type-written inventory list shall be furnished at the time of delivery.

#### 1.14 SHIPPING, HANDLING AND STORAGE

- A. All painting materials shall be brought to the job site in the original sealed labeled containers of the paint manufacturer and shall be subject to review by the ENGINEER. Where thinning is necessary, only the product of the manufacturer furnishing the paint shall be used. All such thinning shall be done strictly in accordance with the manufacturer's instructions, and with the full knowledge of the ENGINEER.
- B. Materials and their storage shall be in full compliance with the requirements of pertinent codes and fire regulations. Receptacles shall be placed outside buildings for paint gates

and containers. Paint waste shall not be disposed of in plumbing fixtures, process drains or other plant systems or process units.

**PART 2 -- PRODUCTS**

**2.01 MATERIALS**

- A. Table 09900-1 depicts the coatings referenced in Article 3.03 of this Section entitled, "Paint Schedule". Table 09900-1 lists Tnemec products as a reference. Equivalent products by the manufacturers listed in Article 1.05 of this Section may be submitted for review.

**Table 09900-1  
Product Listing**

<b>Ref. No.</b>	<b>Description</b>	<b>Manufacturer's Reference</b>
105	Polyamide Epoxy	Tnemec Series 66-Color Hi-Build Epoxoline
108	Modified Polyurethane Primer	Tnemec Series 1 Omnithane
109	Modified Polyamine Epoxy	Tnemec Series G435 Perma-Glaze
110	Aliphatic Acrylic Polyurethane	Tnemec Series 1075 EnduraShield
111	Modified Waterborne Acrylate	Tnemec Series 156 - Envirocrete (Smooth Texture)
113	Polyamine Epoxy	Tnemec Series 215 Surfacing Epoxy
114	Waterborne Modified Polyamine Epoxy	Tnemec Series 151-1051 Elasto-Grip
115	Aromatic Urethane, Zinc Rich	Tnemec Series 90-97 Tneme-Zinc
119	Cycloaliphatic Amine Epoxy	Tnemec Series 104 H.S. Epoxy
123	Waterborne Epoxy	Tnemec Series 287-EnviroPox

**2.02 TRAFFIC PAINT**

- A. Paint for marking parking lots shall be Sherwin-Williams PRO-MAR traffic marking paint, or equal. Color shall be white. Paint shall be applied in accordance with the manufacturer's recommendations.

## PART 3 -- EXECUTION

### 3.01 SURFACE PREPARATION

#### A. General

1. Surfaces to be painted shall be clean and dry, and free of dust, rust, scale and all foreign matter. No solvent cleaning, power or hand tool cleaning shall be permitted unless acceptable to the Engineer or specified herein.
2. Threaded portions of valve and gate stems, machined surfaces which are limited for sliding contact, surfaces which are to be assembled against gaskets, surfaces or shafting on which sprockets are to fit, or which are intended to fit into bearings, machined surfaces of bronze trim on slide gates and similar surfaces shall be masked off to protect them from the sandblasting of adjacent surfaces. Cadmium-plated or galvanized items shall not be sandblasted unless hereinafter specified, except that cadmium-plated, zinc-plated, or sherardized fasteners used in assembly of equipment to the sandblasted shall be sandblasted in the same manner as the unprotected metal. All installed equipment, mechanical drives, and adjacent painted equipment shall be protected from sandblasting. Protection shall prevent any sand or dust from entering the mechanical drive units or equipment where damage could be caused.
3. Hardware accessories, machined surfaces, plates, lighting fixtures, and similar items in place prior to cleaning and painting, and not intended to be painted, shall be protected or removed during painting operations and repositioned upon completion of painting operations.
4. Examine surfaces to be coated to determine that surfaces are suitable for specified surface preparation and painting. Report to Engineer surfaces found to be unsuitable in writing. Do not start surface preparation until unsuitable surfaces have been corrected. Starting surface preparation precludes subsequent claim that such surfaces were unsuitable for the specified surface preparation or painting.
5. Surface preparation shall be in accordance with specifications and manufacturer's recommendations. Provide additional surface preparation, and fill coats where manufacturer recommends additional surface preparation, in addition to requirements of specification.
6. Touch-up shop or field applied coatings damaged by surface preparation or any other activity, with the same shop or field applied coating; even to the extent of applying an entire coat when required to correct damage prior to application of the next coating. Touch-up coats are in addition to the specified applied systems, and not considered a field coat.
7. Protect motors and other equipment during blasting operation to ensure blasting material is not blown into motors or other equipment. Inspect motors and other equipment after blasting operations and certify that no damage occurred, or where damage occurred, the proper remedial action was taken

8. Sand from sandblasting shall be thoroughly removed, using a vacuum cleaner if necessary. No surface which has been sandblasted shall be painted until inspected by the Engineer.
9. Field paint shop painted equipment in compliance with Color Coding and as approved by Engineer.

B. Metal Surfaces

1. Conform to current The Society for Protective Coatings Standards (SSPC) Specifications for metal surface preparation. Use SSPC-Vis-1 pictorial standards or NACE visual standards TM-01-70 or TM-01-75 to determine cleanliness of abrasive blast cleaned steel.
2. Perform blast cleaning operations for metal when following conditions exist:
  - a. Moisture is not present on the surface.
  - b. Relative humidity is below 80%.
  - c. Ambient and surface temperatures are 5°F or greater than the dew point temperature.
  - d. Painting or drying of paint is not being performed in the area.
  - e. Equipment is in good operating condition.
  - f. Proper ventilation, illumination, and other safety procedures and equipment are being provided and followed.
3. All ferrous metal surfaces not required to be galvanized shall be cleaned of all oil grease, dirt, rust and tight and loose mill scale by blasting in accordance with the following: SSPC-SP-5 White Metal Blast Cleaning and comply with the visual standard NACE No. 1, for shop prepared and shop primed metal to be submerged or in a corrosive environment, SSPC-SP10 Near White Metal Blast Cleaning, and comply with the visual standard NACE No. 2 for field prepared metal to be submerged or in a corrosive environment, SSPC-SP6 and comply with the visual standard NACE No. 3 for metal in all other locations. Pickling, complying with SSPC-SP-8, may be substituted for Near White Blast in areas as determined by the Engineer. Priming shall follow sandblasting before any evidence of corrosion occurs, before nightfall and before any moisture is on the surface.
4. Field surface preparation of small, isolated areas such as field welds, repair of scratches, abrasions or other marks to the shop prime or finish shall be cleaned by power tools in accordance with SSPC-SP-3, or in difficult and otherwise inaccessible areas by hand cleaning in accordance with SSPC-SP-2 and spot primed.
5. All coated surfaces shall be cleaned prior to application of successive coats. All non-ferrous metals not to be coated shall be cleaned. This cleaning shall be done in accordance with SSPC-SP-1, Solvent Cleaning.
6. All shop-coated surfaces shall be protected from damage and corrosion before and after installation by treating damaged areas immediately upon detection. Abraded or

corroded spots on shop-coated surfaces shall be prepared in accordance with SSPC-SP-2, Hand Tool Cleaning and then touched up with the same materials as the shop coat.

7. All shop coated surfaces which are faded, discolored, or which require more than minor touch-up, in the opinion of the Engineer, shall be repainted. Cut edges of galvanized sheets, electrical conduit, and metal pipe sleeves, not to be finish painted, shall be cleaned in accordance with SSPC-SP-1, Solvent Cleaning and primed with zinc dust-zinc oxide metal primer.
8. Prime cleaned metals immediately after cleaning to prevent rusting.
9. Clean rusted metals down to bright metal by sandblasting and immediately field primed.

#### C. Concrete Surfaces

1. Concrete surfaces are to be cured for at least 28 days prior to surface preparation, unless coatings are recommended for application over green concrete surfaces.
2. Test concrete for moisture content, pH and salts using test method recommended by the paint manufacturer. Do not begin surface preparation, or painting until moisture content is acceptable to manufacturer.
3. Non-submerged concrete and masonry surfaces to be painted shall be prepared by removing efflorescence, chalk, dust, dirt, grease, oil, form coating, tar and by roughening to remove glaze. All surfaces shall be repaired prior to commencement of the coating operation.
4. Concrete immersion surfaces that are to be coated shall be prepared in accordance to SSPC-SP13/NACE No. 6 to remove all laitance, curing compounds, hardeners, sealers, and other contaminants, and to provide a minimum surface profile. Refer to manufacturer's recommendation for specific coating being applied and adhere to ICRI Concrete Surface Preparation Profiles (CSP 1-10) when reviewing concrete surface preparation. Areas of concrete which contain bug holes or voids shall be filled with the manufacturer's approved filler material.

#### D. Masonry

1. Cure for a minimum of 28 days prior to surface preparation or paint application.
2. Clean masonry surfaces free from all dust, dirt, oil, grease, loose mortar, chalky deposits, efflorescence, and other foreign materials.
3. Test masonry for moisture content. Use test method recommended by paint manufacturer. Do not begin painting until moisture content is acceptable to manufacturer.

#### E. Wood

1. Clean wood surfaces free of all foreign matter, with cracks and nail holes and other defects properly filled and smoothed. Remove sap and resin by scraping and wipe clean with rags dampened with mineral spirits.

2. Saturate end grain, cut wood, knots, and pitch pockets with an appropriate sealer before priming.
3. Prime and backprime wood trim before setting in place.
4. After prime coat has dried, fill nailholes, cracks, open joints, and other small holes with approved spackling putty. Lightly sand wood trim prior to applying second coat of paint.

#### F. Exposed Pipe, Valves and Pumps

1. Bituminous coated pipe shall not be used in exposed locations. Pipe which shall be exposed after project completion shall be primed in accordance with the requirements herein. Any bituminous coated ferrous pipe which is inadvertently installed in exposed locations shall be sandblasted to SSPC-SP-5 White Metal before priming and painting.
2. After installation and prior to finish painting, all exterior, exposed flanged joints shall have the gap between adjoining flanges and gaps between the pipe wall and threaded-on flanges sealed with a single component Thiokol caulking to prevent rust stains.

#### G. Gypsum Drywall

1. Sand joint compound with sandpaper to provide a smooth flat surface. Avoid sanding of adjacent drywall paper.
2. Remove dust, dirt, and other contaminants.

#### H. PVC Pipe Surfaces

1. All pipe surfaces shall be cleaned and lightly sanded before painting.

#### I. Existing Painted Surfaces

1. Totally remove existing paint when: surface is to be submerged in a severe environment, paint is less than 75% intact, brittle, eroded or has underfilm rusting.
2. Surfaces which are greater than 75% intact require removal of failed paints and then spot primed. Spot priming is in addition to coats specified.
3. Remove surface contamination such as oil, grease, loose paint, mill scale, dirt, foreign matter, rust, mold, mildew, mortar, efflorescence, and sealers.
4. Clean and dull glossy surfaces prior to painting in accordance with the manufacturer's recommendations.
5. Check existing paints for compatibility with new paint system. If incompatible, totally remove existing paint system or apply a barrier coat recommended by the paint manufacturer. Remove existing paints of undetermined origin. Prepare a test patch of approximately 3 square feet over existing paint. Allow test patch to dry thoroughly and test for adhesion. If proper adhesion is not achieved remove existing paint and repaint.

### 3.02 SHOP PAINTING

- A. All fabricated steel work and equipment shall receive at the factory at least one shop coat of prime paint compatible with the paint system required by these Specifications. The CONTRACTOR shall coordinate all shop priming to ensure compatibility with paint system specified. Surface preparation prior to shop painting shall be as specified. Finish coats may be applied in the shop if acceptable to the ENGINEER. All shop painted items shall be properly packaged and stored until they are incorporated in the Work. Any painted surfaces that are damaged during handling, transporting, storage or installation shall be cleaned, scraped, and patched before field painting begins so that Work shall be equal to the original painting received at the shop. Equipment or steel Work that is to be assembled on the site shall likewise receive a minimum of one shop coat of paint at the factory. Surfaces of exposed members that will be inaccessible after erection shall be prepared and painted before erection.
- B. The CONTRACTOR shall specify the shop paints to be applied when ordering equipment in order to assure compatibility of shop paints with field paints. The paints and surface preparation used for shop coating shall be identified on shop drawings submitted to the ENGINEER for review. Shop paint shop drawings will not be reviewed until the final project paint system has been submitted by the CONTRACTOR and reviewed by the ENGINEER.
- C. Shop finish coats may be the standard finish as ordinarily applied by the manufacturer if it can be demonstrated to the ENGINEER that the paint system is equal to and compatible with the paint system specified. However, all pumps, motors and other equipment shall receive at least one field applied finish coat after installation.

### 3.03 PAINT SCHEDULE

- A. The CONTRACTOR shall adhere to this paint schedule, providing those paints named or equal. DFT shall mean the minimum dry film thickness per application measured in mils. Products are referenced by numbers listed in Article 2.01 of this Section entitled "Product Listing." The paint schedule identifies the minimum DFT required per coat. If the CONTRACTOR does not achieve the specified DFT range in a single coat, it shall provide additional coats as necessary at no additional cost to the CITY.
- B. Metal Surfaces, Atmospheric (Exterior) Exposure
  - 1. Metal surfaces exposed to the atmosphere that do not come into contact with wastewater or corrosive atmosphere including the following types of surfaces shall be painted as described below:
    - a. Pumps, motors, process equipment, machinery, etc.
    - b. Above ground piping, valves and pipe supports.
    - c. Miscellaneous steel shapes, angles, etc.
    - d. Exposed surfaces of conduit, ductwork, etc.
  - 2. Surface preparation: SSPC-SP6

**Ferrous Metal**

<u>Application</u>	<u>No.</u>	<u>Description</u>	<u>DFT</u>
First - 1 coat	105	Hi-Build Epoxoline	4.0 - 6.0
Spot repair	113	Surfacing Epoxy	(as needed)
Second - 1 coat	105	Hi-Build Epoxoline	3.0 - 5.0
Finish - 1 coat	110	Endura Shield II	<u>3.0 - 4.0</u>
		Min. Total	12.0 Mils

**Non-Ferrous Metal**

<u>Application</u>	<u>No.</u>	<u>Description</u>	<u>DFT</u>
First - 1 coat	105	Hi-Build Epoxoline	2.0 - 3.0
Second - 1 coat	110	Endura Shield II	<u>2.0 - 3.0</u>
		Min. Total	5.0 Mils

**Galvanized**

<u>Application</u>	<u>No.</u>	<u>Description</u>	<u>DFT</u>
Spot repair	115	Aromatic Urethane, Zinc-Rich	2.0 - 3.0 (spot)
First - 1 coat	105	Hi-Build Epoxoline	2.0 - 3.0
Second - 1 coat	110	Endura Shield II	<u>2.0 - 3.0</u>
		Min. Total	5.0 Mils

C. Metal Surfaces, Interior Exposure

1. Interior metal surfaces (nonsubmerged) that do not come in contact with wastewater or the corrosive atmosphere including the following types of surfaces shall be painted as follows:
  - a. Pumps, motors, process equipment, machinery, etc.
  - b. Piping, valves and supports.
  - c. Miscellaneous steel shapes, angles, rails, etc.
  - d. Exposed surfaces of conduit, ductwork, etc.
2. Surface preparation: SSPC-SP6

<u>Application</u>	<u>No.</u>	<u>Description</u>	<u>DFT</u>
First - 1 coat	105	Hi-Build Epoxoline	3.0 - 5.0
Finish - 1 coat	105	Hi-Build Epoxoline	<u>4.0 - 6.0</u>
		Min. Total	9.0 Mils

D. Metal Surfaces, Submerged Exposure

1. Metal surfaces that are submerged in wastewater or subjected to wastewater gases, including but not limited to the following surfaces, shall be painted as described below:



CLARIFIER No. 3 (UNDER ALTERNATE BID ITEM):

- a. Mechanism, including center feed well, center column, sludge collection box, rake arms and miscellaneous metals.
- b. Steel (ungalvanized) sections of Clarifier walkway
- c. All metal surfaces furnished and installed with Clarifier No. 3 equipment.
- d. Miscellaneous steel shapes, angles, rails, etc.

2. Surface preparation: SSPC-SP10

<u>Application</u>	<u>No.</u>	<u>Description</u>	<u>DFT</u>
Prime coat	108	Series 1 Omnithane	2.5 - 3.5
Spot repair	113	Series 215 Surfacing Epoxy	(as needed)
Second coat	109	Series G435 Perma-Glaze	20.0 – 25.0
Finish coat	109	Series G435 Perma-Glaze	<u>20.0 – 25.0</u>
		Min. Total	47.0 Mils

E. Ductile Iron Pipe, Exterior or Interior Exposure

1. Ductile iron pipe exterior or interior exposure shall receive the following types of paint:
2. Surface preparation: SSPC-SP6

<u>Application</u>	<u>No.</u>	<u>Description</u>	<u>DFT</u>
First - 1 coat	105	Hi-Build Epoxoline	6.0 - 10.0
Finish - 1 coat	110	Endura Shield II	<u>3.0 - 5.0</u>
		Min. Total	12.0 Mils

F. PVC/CPVC Pipes, Exterior or Interior Exposure

1. PVC/CPVC pipes, valves, and accessories, shall receive the following types of paint:
2. Surface preparation: Light sanding

<u>Application</u>	<u>No.</u>	<u>Description</u>	<u>DFT</u>
First - 1 coat	105	Hi-Build Epoxoline	2.0 - 3.0
Finish - 1 coat	110	Endura Shield II	<u>2.0 - 3.0</u>
		Min. Total	5.0 Mils

G. Existing Concrete, Stucco and Masonry Surfaces identified for painting or requiring Touch-Up caused by CONTRACTOR's Construction Activities, Exterior Exposure

1. Exteriors of existing structures shall be painted as identified herein. Paint colors and color scheme shall match existing.

2. Surface preparation: Remove unsound paint, excess mortar, laitance, and efflorescence. Pressure wash with TSP/Chlorine solution and freshwater rinse.

<u>Application</u>	<u>No.</u>	<u>Description</u>	<u>DFT</u>
First - 1 coat	114	Waterborne Polyamide Epoxy	1.0 - 2.5
Brush - 1 coat*	111	Modified Waterborne Acrylate	4.0 - 6.0
Finish - 1 coat	111	Modified Waterborne Acrylate	<u>4.0 - 6.0</u>
		Min. Total	10.0 Mills

*\*Apply a brush coat of TNEMEC Series 156 Enviro-Crete into all exposed cracks prior to application of finish coat.*

- H. Existing Painted Concrete and Masonry Surfaces noted for coating or requiring touch-up caused by CONTRACTOR's construction activities or identified herein to be coated, Interior Exposure

1. Interior exposed masonry and concrete surfaces including the entire interior surfaces shall be painted as described below:
2. Surface preparation: Remove unsound paint, excess mortar, laitance, and efflorescence. Pressure wash with TSP/Chlorine solution and freshwater rinse.

<u>Application</u>	<u>No.</u>	<u>Description</u>	<u>DFT</u>
First - 1 coat	105	Hi-Build Epoxoline	4.0 - 6.0
Finish - 1 coat	105	Hi-Build Epoxoline	<u>4.0 - 6.0</u>
		Minimum Total	10.0 Mills

### 3.04 PAINTING

- A. Application: All paint shall be applied by experienced painters with brushes or other applicators acceptable to the ENGINEER.

1. Paint shall be applied without runs, sags, thin spots, or unacceptable marks. Paints shall be applied at the rate specified by the manufacturer to achieve the minimum dry mil thickness required. Additional coats of paint shall be applied, if necessary, to obtain thickness specified.
2. Paint shall be applied with spraying equipment only on those surfaces approved by the ENGINEER. If the material has thickened or must be diluted for application by spray gun, each coat shall be built up to the same film thickness achieved with undiluted brushed-on material. Where thinning is necessary, only the products of the particular manufacturer furnishing the paint shall be used; and all such thinning shall be done in strict accordance with the manufacturer's instructions, as well as with the full knowledge of the ENGINEER.
3. Surfaces not accessible to brushes or rollers may be painted by spray by dauber or sheepskins and paint mitt. If any of these methods is to be used, it shall be done in

strict accordance with the manufacturer's instructions, as well as with the full knowledge of the ENGINEER.

4. Special attention shall be given to nuts, bolts, edges, angles, flanges, etc., where insufficient film thicknesses are likely. Stripe paint prior to applying prime coat. Stripe painting shall be in addition to coats specified.
  5. Perform thinning in strict accordance with the manufacturer's instructions, and with the full knowledge and approval of the Engineer and paint manufacturer.
- B. Drying Time: A minimum of twenty-four hours drying time shall elapse between application of any two coats of paint on a particular surface unless shorter time periods are a requirement of the manufacturer or specified herein. Longer drying times shall be required for abnormal conditions as defined by the manufacturer.
- C. Weather Restrictions
1. No painting whatsoever shall be accomplished in rainy or excessively damp weather when the relative humidity exceeds 85 percent, or when the general air temperature cannot be maintained at 50 degrees Fahrenheit or above throughout the entire drying period. No paint shall be applied when it is expected that the relative humidity will exceed 85 percent or that the air temperature will drop below 50 degrees Fahrenheit within 18 hours after the application of the paint.
  2. Dew or moisture condensation should be anticipated; and if such conditions are prevalent, painting shall be delayed until midmorning to be certain the surfaces are dry. The day's painting shall be completed well in advance of the probable time-of-day when condensation will occur.
- D. Inspection of Surfaces:
1. Surface preparation and every field coat of priming and finishing paint shall be inspected by the ENGINEER or his authorized representative before the succeeding coat is applied. The CONTRACTOR shall follow a system of tinting successive paint coats so that no two coats for a given surface are exactly the same color. Areas to receive black protective coatings shall in such cases be tick-marked with white or actually gauged as to thickness when finished.
  2. Before application of the prime coat and each succeeding coat, any defects or deficiencies in the prime coat or succeeding coat shall be corrected by the CONTRACTOR before application of any subsequent coating.
  3. Samples of surface preparation and of painting systems shall be furnished by the CONTRACTOR to be used as a standard throughout the job, unless omitted by the ENGINEER.
  4. When any appreciable time has elapsed between coatings, previously coated areas shall be carefully inspected by the ENGINEER, and where, in his opinion, surfaces are damaged or contaminated, they shall be cleaned and recoated at the CONTRACTOR's expense. Recoating times of manufacturer's printed instructions shall be adhered to.

5. Coating thickness shall be verified by the use of a dry film thickness digital gauge. Gauge shall be Elcometer 456 or equal and shall be properly calibrated. Coating thickness on non-metal surfaces shall be verified by the use of an ultrasonic gauge. Ultrasonic gauge shall be Positector 200 or equal. Gauges shall include the entire range of coating thicknesses required in this section.
  6. The Contractor shall provide free of charge to the Engineer two new digital dry film gauges and two wet film gauges to be used to inspect coating by Engineer and Contractor. One gauge may be used by Contractor and returned each day to the Engineer. Engineer will return gauges to Contractor at completion of job.
  7. Coatings shall pass a holiday detector test. Testing shall be performed under the supervision of the ENGINEER, Manufacturer's Representative, and Owner
  8. Determination of Film Thickness: Randomly selected areas, each of at least 107.5 contiguous square feet, totaling at least 5% of the entire control area shall be tested. Within this area, at least 5 squares, each of 7.75 square inches, shall be randomly selected. Three readings shall be taken in each square, from which the mean film thickness shall be calculated. No more than 20 percent of the mean film thickness measurements shall be below the specified thickness. No single measurement shall be below 80 percent of the specified film thickness. Total dry film thickness greater than twice the specified film thickness shall not be acceptable. Areas where the measured dry film thickness exceeds twice that specified shall be completely redone unless otherwise approved by the Engineer. When measured dry film thickness is less than that specified additional coats shall be applied as required.
  9. Holiday Testing: Holiday test painted ferrous metal surfaces which will be submerged in water or other liquids, or surfaces which are enclosed in a vapor space in such structures. Testing shall be performed under the supervision of the ENGINEER, Manufacturer's Representative, and Owner. Mark areas which contain holidays. Repair or repaint in accordance with paint manufacturer's printed instructions and retest.
    - a. Dry Film Thickness Exceeding 20 Mils: For surfaces having a total dry film thickness exceeding 20 mils: Pulse-type holiday detector such as Tinker & Razor Model AP-W, D.E. Stearns Co. Model 14/20, shall be used. The unit shall be adjusted to operate at the voltage required to cause a spark jump across an air gap equal to twice the specified coating thickness.
    - b. Dry Film Thickness of 20 Mils or Less: For surfaces having a total dry film thickness of 20 mils or less: Tinker & Razor Model M1 non-destructive type holiday detector, K-D Bird Dog, shall be used. The unit shall operate at less than 75-volts. For thicknesses between 10 and 20 mils, a non-sudsing type wetting agent, such as Kodak Photo-Flow, shall be added to the water prior to wetting the detector sponge.
- E. Special Areas: All surfaces which are to be installed against concrete, masonry etc., and will not be accessible for field priming and/or painting shall be back primed and painted as

specified herein, before erection. Anchor bolts shall be painted before the erection of equipment and then the accessible surfaces repainted when the equipment is painted.

- F. Special attention shall be given to insure that edges, corners, crevices, welds and rivets receive a film thickness equivalent to that of the adjacent painted surfaces.
- G. Safety: Respirators shall be worn by persons engaged or assisting in spray painting. The CONTRACTOR shall provide ventilating equipment and all necessary safety equipment for the protection of the workmen and the Work.
- H. Quality Workmanship: The CONTRACTOR shall be responsible for the cleanliness of his painting operations and shall use covers and masking tape to protect the Work whenever such covering is necessary, or if so requested by the CITY. Any unwanted paint shall be carefully removed without damage to any finished paint or surface. If damage does occur, the entire surface, adjacent to and including the damaged area, shall be repainted without visible lapmarks and without additional cost to the CITY.
- I. Painting found defective shall be scraped or sandblasted off and repainted as the ENGINEER may direct. Before final acceptance of the Work, damaged surfaces of paint shall be cleaned and repainted as directed by the ENGINEER.

### 3.05 SCHEDULE OF COLORS

- A. All colors shall be as designated by the ENGINEER at the shop drawing review. The CONTRACTOR shall submit color samples including custom color choices as required to the ENGINEER as specified in Article 1.04 of this Section. The CONTRACTOR shall submit suitable samples of all colors and finishes for the surfaces to be painted, or on portable surfaces when required by the ENGINEER. The ENGINEER shall decide upon the choice of colors and other finishes when alternates exist. No variation shall be made in colors without the acceptance from the CITY. Color names and/or numbers shall be identified according to the appropriate color chart issued by the manufacturer of the particular product in question.

### 3.06 COLOR CODING AND LETTERING OF PIPING

- A. The CONTRACTOR shall paint all piping, valves, exposed conduits and all appurtenances which are integral to a complete functional mechanical pipe and electrical conduit system, in accordance with Section 15030 – “Piping and Equipment Identifications”. Where colors are not designated for piping and conduit systems they will be selected during the shop drawing review from the paint manufacturer's standard color charts.

- END OF SECTION -

**DIVISION 10 – SPECIALTIES**

**DIVISION 11 – EQUIPMENT**

## SECTION 11000 - EQUIPMENT GENERAL PROVISIONS

### PART 1 -- GENERAL

#### 1.01 THE REQUIREMENT

- A. The CONTRACTOR shall furnish, install, test, and place in acceptable operation all mechanical equipment and all necessary accessories as specified herein, as shown on the Drawings, and as required for a complete and operable system.
- B. The mechanical equipment shall be provided complete with all accessories, special tools, spare parts, mountings, and other appurtenances as specified, and as may be required for a complete and operating installation.
- C. It is the intent of these Specifications that the CONTRACTOR shall provide the CITY complete and operational equipment/systems. To this end, it is the responsibility of the CONTRACTOR to coordinate all interfaces with related mechanical, structural, electrical, instrumentation and control work and to provide necessary ancillary items such as controls, wiring, etc., to make each piece of equipment operational as intended by the Specifications.
- D. The complete installation shall be free from excessive vibration, cavitation, noise, and oil or water leaks.
- E. The requirements of this section shall apply to equipment furnished under Divisions 11, 13, 14, and 15.

#### 1.02 REFERENCE SPECIFICATIONS, CODES, AND STANDARDS

- A. All equipment, materials, and installations shall conform to the requirements of the most recent editions with latest revisions, supplements, and amendments of the specifications, codes, and standards listed in Section 01090, Reference Standards.

#### 1.03 PERFORMANCE AFFIDAVITS

- A. When required in the individual equipment Specifications, the CONTRACTOR shall submit manufacturer's Performance Affidavits for equipment to be furnished.
- B. By these affidavits, each manufacturer must certify to the CONTRACTOR and the CITY, jointly, that he has examined the Contract Documents and that the equipment, apparatus, or process he offers to furnish will meet in every way the performance requirements set forth or implied in the Contract Documents.
- C. The CONTRACTOR must transmit to the ENGINEER three (3) original copies of the affidavit given him by the manufacturer or supplier along with the initial Shop Drawing submittals.
- D. The Performance Affidavit must be signed by an officer of the basic corporation, partnership, or company manufacturing the equipment and witnessed by a notary public.



E. The Performance Affidavit shall have the following format:

Addressed to: (CONTRACTOR) and City of Hollywood (CITY)

Reference: SRWWTP RAS Pump Station No. 2 Replacement

Text: (Manufacturer's Name) has examined the Contract Documents and hereby state that the (Product) meets in every way the performance requirements set forth or implied in Section \_\_\_\_ of the Contract Documents.

Signature: Corporate Officers shall be Vice President, or higher. (Unless statement authorizing signature is attached.)

#### 1.04 SHOP DRAWINGS

A. Shop Drawings shall be submitted to the ENGINEER for all equipment in accordance with Section 01300, Submittals and shall include the following information in addition to the requirements of Section 01300, Submittals:

1. Performance characteristics and descriptive data.
2. Detailed equipment dimensional drawings and setting plans.
3. General lifting, erection, installation, and adjustment instructions, and recommendations.
4. Complete information regarding location, type, size, and length of all field welds in accordance with "Standard Welding Symbols" AWS A2.0 of the American Welding Society. Special conditions shall be fully explained by notes and details.
5. The total uncrated weight of the equipment plus the approximate weight of shipped materials. Support locations and loads that will be transmitted to bases and foundations. Exact size, placement, and embedment requirements of all anchor bolts.
6. Details on materials of construction of all components including applicable ASTM designations.
7. Information on bearing types and bearing life.
8. Gear box design and performance criteria and AGMA service factor.
9. Piping schematics.
10. Motor data sheet indicating motor horsepower; enclosure type; voltage; insulation class; temperature rise and results of dielectric tests; service-rating; rotative speed; motor speed-torque relationship; efficiency and power factor at 1/2, 3/4 and full load; slip at full load; running, full load, and locked rotor current values; and safe running time-current curves. Refer to Specification Section 16405.

11. Equipment and motor protective device details. Connection diagrams for motor and all protective devices.
12. Equipment shop coating systems, interior and exterior.
13. Panel layout drawings, schematic wiring diagrams, and component product data sheets for control panels.
14. A list of spare parts and special tools to be provided.
15. Any additional information required to show conformance with the equipment specifications.
16. Warranty documentation including statement of duration of warranty period and contact phone numbers and addresses for warranty issues.

B. SHOP DRAWINGS ON ITEMS REQUIRING PERFORMANCE AFFIDAVITS WILL NOT BE REVIEWED UNTIL ACCEPTABLE PERFORMANCE AFFIDAVITS ARE RECEIVED.

1.05 OPERATION AND MAINTENANCE INSTRUCTION/MANUALS

- A. Operation and Maintenance (O&M) manuals shall be submitted in accordance with Section 01300.

1.06 GENERAL INFORMATION AND DESCRIPTION

- A. All parts of the equipment furnished shall, be designed and constructed for the maximum stresses occurring during fabrication, transportation, installation, testing, and all conditions of operation. All materials shall be new, and both workmanship and materials shall be entirely suitable for the service to which the units are to be subjected and shall conform to all applicable sections of these Specifications.
- B. All parts of duplicate equipment shall be interchangeable without modification. Manufacturer's design shall accommodate all the requirements of these Specifications.
- C. Equipment and appurtenances shall be designed in conformity with ASTM, ASME, AIEE, NEMA, and other generally accepted applicable standards.
- D. All bearings and moving parts shall be adequately protected by bushings or other approved means against wear, and provision shall be made for accessible lubrication by extending lubrication lines and fittings to approximately 30 inches above finished floor elevation.
- E. Details shall be designed for appearance as well as utility. Protruding members, joints, corners, gear covers, etc., shall be finished in appearance. All exposed welds on machinery shall be ground smooth and the corners of structural shapes shall be rounded or chamfered.
- F. Machinery parts shall conform within allowable tolerances to the dimensions shown on the working drawings.
- G. All machinery and equipment shall be safeguarded in accordance with the safety codes of the USA and the State in which the project is located.

- H. All rotating shafts, couplings, or other moving pieces of equipment shall be provided with suitable protective guards of sheet metal or wire mesh, neatly and rigidly supported. Guards shall be removable as required to provide access for repairs.
- I. All equipment greater than 100 pounds shall have lifting lugs, eyebolts, etc., for ease of lifting, without damage or undue stress exerted on its components.
- J. All manufactured items provided under this Section shall be new, of current manufacture, and shall be the products of reputable manufacturers specializing in the manufacture of such products.

#### 1.07 EQUIPMENT WARRANTIES

- A. Warranty requirements may be added to or modified in the individual equipment specifications.
- B. The equipment furnished under this Contract shall be guaranteed to be free from defects in workmanship, design and/or materials for a period of one (1) year unless otherwise specified in the individual equipment specifications. The period of such warranties shall start on the date the particular equipment is placed in use by the CITY with corresponding start-up certification provided by the manufacturer's technical representative as specified herein, provided that the equipment demonstrates satisfactory performance during the thirty day operational period after the equipment startup. If the equipment does not perform satisfactorily during the thirty day operational period, the start of the warranty period will be delayed until the equipment demonstrates proper operation. The Equipment Supplier shall repair or replace without charge to the CITY any part of equipment which is defective or showing undue wear within the guarantee period, or replace the equipment with new equipment if the mechanical performance is unsatisfactory; furnishing all parts, materials, labor, etc., necessary to return the equipment to its specified performance level. Repairs made during the warranty period shall include any required re-balancing.
- C. The CONTRACTOR shall provide an equipment warranty log book prepared specifically for this project and submit two (2) copies of the document to the ENGINEER prior to final payment. The equipment warranty log book shall include a summary listing of all equipment warranties provided, date received, and start date and end date of warranty period. A copy of each equipment warranty and equipment start-up certification shall also be provided in the document.
- D. The Equipment Supplier shall guarantee to the CITY that all equipment offered under these specifications, or that any process resulting from the use of such equipment in the manner stated is not the subject of patent litigation, and that he has not knowingly offered equipment, the installation or use of which is likely to result in a patent controversy, in which the CITY as user is likely to be made the defendant.
- E. Where patent infringements are likely to occur, each Equipment Supplier shall submit, as a part of his bid, license arrangements between himself, or the manufacturer of the equipment offered, and the patent CITY or the controller of the patent, which will permit the use in the specified manner of such mechanical equipment as he may be bidding.

- F. Each Equipment Supplier, by submitting his bid, agrees to hold and save the CITY and ENGINEER or its officers, agents, servants, and employees harmless from liability of any nature or kind, including cost and expenses for, or on account of, any patented or unpatented invention, process, article, or appliance manufactured or used in the performance of the work under this contract, including the use of the same by the CITY.

## PART 2 -- PRODUCTS

### 2.01 ACCEPTABLE MANUFACTURERS

- A. The materials covered by these Specifications are intended to be equipment of proven reliability, and as manufactured by reputable manufacturers having experience in the production of such equipment. The CONTRACTOR shall, upon request of the ENGINEER, furnish the names of not less than 5 successful installations of the manufacturer's equipment of the same size and model of that offered under this contract. The equipment furnished shall be designed, constructed, and installed in accordance with the industry accepted practices and shall operate satisfactorily when installed as shown on the Drawings and operated per manufacturer's recommendations.

### 2.02 ANCHORS AND SUPPORTS

- A. The CONTRACTOR shall furnish, install, and protect all necessary guides, bearing plates, anchor and attachment bolts, and all other appurtenances required for the installation of the devices included in the equipment specified. Working Drawings for installation shall be furnished by the equipment manufacturer, and suitable templates shall be used by the CONTRACTOR when required in the detailed equipment Specifications.
- B. Anchor bolts and fasteners shall be furnished in accordance with Section 05050, Metal Fastening, and with the individual equipment Specifications. All anchor bolts shall be a minimum of 1/2-inch diameter. All anchor bolts, handrail bolts, washers, clips, clamps, and fasteners of any type shall be constructed of 316 stainless steel, unless otherwise specified in the individual equipment Specifications.
- C. The CONTRACTOR shall provide all concrete pads or pedestals required for equipment furnished. All concrete equipment pads shall be a minimum of 6" high, unless otherwise shown on the Drawings and shall be doweled.
- D. Pipe sleeves or other means of adjusting anchor bolts shall be provided where indicated or required. Equipment shall be leveled by first using sitting nuts on the anchor bolts, and then filling the space between the equipment base and concrete pedestal with non-shrink grout, unless alternate methods are recommended by the manufacturer and are acceptable to the ENGINEER (such as shim leveling pumps, or chemical grout). Non-shrink grout shall be as specified in Section 03315 - Grout.

### 2.03 STRUCTURAL STEEL

- A. Structural steel used for fabricating equipment shall conform to the requirements of Division 5.

- B. All materials shall conform to applicable provisions of the AISC Specifications for the design and fabrication of structural steel, and to pertinent ASTM Standard Specifications.

#### 2.04 DISSIMILAR METALS

- A. All dissimilar metals shall be properly isolated to the satisfaction of the ENGINEER.

#### 2.05 GALVANIZING

- A. Where required by the equipment specifications, galvanizing shall be performed in accordance with Division 5.

#### 2.06 STANDARDIZATION OF GREASE FITTINGS

- A. The grease fittings on all mechanical equipment shall be such that they can be serviced with a single type of grease gun. Fittings shall be "Zerk" type.

#### 2.07 ELECTRICAL REQUIREMENTS

- A. All electrical equipment and appurtenances, including but not limited to motors, panels, conduit and wiring, etc., specified in the equipment specifications shall comply with the applicable requirements of the Division 16 specifications and the latest National Electric Code.
- B. Motors shall conform to the applicable requirements of Section 16040, Electric Motors.
- C. In the individual equipment specifications, specified motor horsepower is intended to be the minimum size motor to be provided. If a larger motor is required to meet the specified operating conditions and performance requirements, the CONTRACTOR shall furnish the larger sized motor and shall upgrade the electrical service (conduit, wires, starters, etc.) at no additional cost to the CITY.
- D. Where variable frequency drives (VFDs) are specified, the CONTRACTOR shall be responsible for coordinating between equipment supplier and VFD supplier to ensure a complete and operational system. VFDs shall be furnished under Division 16 and shall be as specified in Section 16435, Variable Frequency Drive Systems.
- E. Motor starters and controls shall be furnished and installed under Division 16 and Division 17 unless otherwise specified in the individual pump specifications.

#### 2.08 ACCESSORIES, SPARE PARTS, AND SPECIAL TOOLS

- A. Spare parts for equipment shall be furnished where indicated in the equipment Specifications or where recommended by the equipment manufacturer.
- B. Spare parts shall be identical and interchangeable with original parts.
- C. The spare parts shall be packed in containers suitable for long term storage, bearing labels clearly designating the contents and the pieces of equipment for which they are intended.

- D. Painting requirements for spare parts shall be identical to those for original, installed parts. Where no painting or protective coating is specified, suitable provisions shall be made to protect against corrosion.
- E. Spare parts shall be delivered at the same time as the equipment to which they pertain. Spare parts shall be stored separately in a locked area, maintained by the CONTRACTOR, and shall be turned over to the CITY in a group prior to substantial completion. All of these materials shall be properly packed, labeled, and stored where directed by the CITY and ENGINEER.
- F. The CONTRACTOR shall furnish all special tools necessary to operate, disassemble, service, repair, and adjust the equipment in accordance with the manufacturers operation and maintenance manual.
- G. The CONTRACTOR shall furnish a one year supply of all recommended lubricating oils and greases. The manufacturer shall submit a list of at least four manufacturer's standard lubricants which may be used interchangeably for each type of lubricant required. All of these materials shall be properly packed, labeled and stored where directed by the ENGINEER.

## 2.09 EQUIPMENT IDENTIFICATION

- A. All mechanical equipment shall be provided with a substantial stainless steel nameplate, mechanically fastened with stainless steel hardware in a conspicuous place, and clearly inscribed with the manufacturer's name, year of manufacture, serial number, and principal rating data.
- B. All equipment provided under Divisions 11 through 15 including motorized and manual gates and valves (aboveground and buried) shall also be identified as to the equipment name and equipment tag number by a suitable laminated plastic or stainless steel nameplate mechanically fastened with stainless steel hardware; for example, "Mechanical Bar Screen No. 1: MBS 01001". Equipment names and equipment tag numbers shall match the names provided for the equipment as identified on the Drawings and in the Specifications. Equipment names and tag numbers not currently identified in the Drawings and Specifications shall be provided to the CONTRACTOR prior to the fabrication of the nameplates. Coordinate name and number with same on remotely located controls, control panel, and other related equipment. For buried valve applications, the valve name and number shall be included in the bronze disc embedded in the valve's concrete collar as identified on the Drawings.
- C. Nameplates shall not be painted over.

## PART 3 -- EXECUTION

### 3.01 SHOP TESTING

- A. All equipment shall be tested in the shop of the manufacturer in a manner which shall conclusively prove that its characteristics comply fully with the requirements of the Contract Documents and that it will operate in the manner specified or implied.

- B. No equipment shall be shipped to the project until the ENGINEER has been furnished a certified copy of test results and has notified the CONTRACTOR, in writing, that the results of such tests are acceptable.
- C. Five (5) certified copies of the manufacturer's actual test data and interpreted results thereof shall be forwarded to the ENGINEER for review.
- D. If required by the individual equipment Specifications, arrangements shall be made for the CITY/ENGINEER to witness performance tests in the manufacturer's shop. The ENGINEER shall be notified ten working days before shop testing commences.
- E. Shop testing of electric motors shall be in accordance with applicable requirements of Section 16040, Electric Motors and Section 16000, Basic Electrical Requirements.

### 3.02 STORAGE OF EQUIPMENT AND MATERIALS

- A. CONTRACTOR shall store his equipment and materials at the job site in strict accordance with the manufacturer's recommendations and as directed by the CITY or ENGINEER, and in conformity to applicable statutes, ordinances, regulations, and rulings of the public authority having jurisdiction. Equipment and materials shall not be delivered to the site prior to 90 days in advance of the scheduled installation. Partial payment requests will not be processed for materials delivered prior to 90 days before installation or for materials that are not properly stored.
- B. Material or equipment stored on the job site is stored at the CONTRACTOR's risk. Any damage sustained of whatever nature shall be repaired to the ENGINEER's satisfaction at no expense to the CITY. Stored electrical equipment is to be protected from the elements and shall have space heaters energized.
- C. CONTRACTOR shall not store unnecessary materials or equipment on the job site and shall take care to prevent any structure from being loaded with a weight which will endanger its security or the safety of persons.
- D. CONTRACTOR shall observe all regulatory signs for loadings on structures, fire safety, and smoking areas.
- E. CONTRACTOR shall not store materials or encroach upon private property without the written consent of the owner of such private property.

### 3.03 MANUFACTURER'S FIELD SERVICES

- A. The CONTRACTOR shall arrange for a qualified Technical Representative from each manufacturer or supplier of equipment who is regularly involved in the inspection, installation, start-up, troubleshooting, testing, maintenance, and operation of the specified equipment. Qualification of the Technical Representative shall be appropriate to the type of equipment furnished and subject to the approval of the ENGINEER and the CITY. Where equipment furnished has significant process complexity, furnish the services of engineering personnel knowledgeable in the process involved and the function of the equipment. When necessary, the CONTRACTOR shall schedule multiple Technical Representatives to be present at the same time for the purpose of coordinating the operation of multiple pieces of related equipment.

- B. For each site visit, the Technical Representative shall submit jointly to the CITY, the ENGINEER, and the CONTRACTOR a complete signed report of the results of his inspection, operation, adjustments, and testing. The report shall include detailed descriptions of the points inspected, tests and adjustments made, quantitative results obtained if such are specified.
- C. The manufacturer's Technical Representative shall provide the following services.
1. Installation: The Technical Representative shall inspect the installed equipment to verify that installation is in accordance with the manufacturer's requirements. Where required by individual equipment specifications, the Technical Representative shall also supervise the installation of the equipment.
  2. Testing: After installation of the equipment has been completed and the equipment is presumably ready for operation, but before it is operated by others, the Technical Representative shall inspect, operate, test, and adjust the equipment as required to prove that the equipment is in proper condition for satisfactory operation under the conditions specified. Unless otherwise noted in the signed site visit report, the report shall constitute a certification that the equipment conforms to the requirements of the Contract and is ready for startup and that nothing in the installation will render the manufacturer's warranty null and void. The report shall include date of final acceptance field test, as well as a listing of all persons present during tests.
  3. Startup: The Technical Representative shall start up the equipment for actual service with the help of the CONTRACTOR. In the event that equipment or installation problems are experienced, the CONTRACTOR and the representative shall provide the necessary services until the equipment is operating satisfactorily and performing according to the specifications at no additional cost to the CITY. Unless otherwise noted in the signed site visit report, the report shall constitute a certification that the equipment conforms to the requirements of the Contract and is ready for permanent operation and that nothing in the installation will render the manufacturer's warranty null and void.
  4. Training: The Technical Representative shall instruct the CITY's operating personnel in correct operation and maintenance procedures. The instruction shall demonstrate start-up, operation, control, adjustment, trouble-shooting, servicing, maintenance, and shutdown of each item of equipment. Such instruction shall be scheduled at a time arranged with the CITY at least 2 weeks in advance of the training and shall be provided while the respective Technical Representative's equipment is fully operational. The CONTRACTOR shall submit an Agenda for approval prior to scheduling. The CONTRACTOR shall have submitted, and had accepted, the O&M Manuals prior to commencement of training. Training shall be provided to four separate shifts of the CITY's personnel between the hours of 6:00 A.M. and 6:00 P.M. as necessary. The CONTRACTOR shall provide professional video recordings of all training sessions. Completed, labeled recordings shall be provided to the CITY for each type of training session.
  5. Services after Startup: Where required by the individual equipment specifications, the Technical Representative shall return to the project site thirty (30) days after the



start up date to review the equipment performance, correct any equipment problems, and conduct operation and maintenance classes as required by the CITY. This follow-up trip is required in addition to the specified services of Technical Representative prior to and during equipment startup. At this time, if there are no equipment problems, each manufacturer shall certify to the CITY in writing that his equipment is fully operational and capable of meeting operating requirements. If the equipment is operating incorrectly, the Technical Representative will make no certification to the CITY until the problems are corrected and the equipment demonstrates a successful thirty (30) days operating period.

- D. Services of the Technical Representative will require a minimum of two (2) site visits, one for installation and testing and one for startup and training, and will be for the minimum number of days recommended by the manufacturer and approved by the ENGINEER but will not be less than the number of days specified in individual equipment sections.
- E. The Contract amount shall include the cost of furnishing the Technical Representative for the minimum number of days specified, and any additional time required to achieve successful installation and operation. The times specified for services by the Technical Representative in the equipment Specifications are exclusive of travel time to and from the facility and shall not be construed as to relieve the manufacturer of any additional visits to provide sufficient service to place the equipment in satisfactory operation.
- F. The CONTRACTOR shall notify the ENGINEER at least 14 days in advance of each equipment test or CITY training session.
- G. The Technical Representative shall sign in and out at the office of the ENGINEER's Resident Project Representative on each day he is at the project.

### 3.04 INSTALLATION

- A. The CONTRACTOR shall obtain written installation manuals from the equipment manufacturer prior to installation. Equipment shall be installed strictly in accordance with recommendations of the manufacturer. A copy of all installation instructions shall be furnished the ENGINEER's field representative one week prior to installation.
- B. The CONTRACTOR shall have on hand sufficient personnel, proper construction equipment, and machinery of ample capacity to facilitate the work and to handle all emergencies normally encountered in work of this character. To minimize field erection problems, mechanical units shall be factory-assembled insofar as practical.
- C. Equipment shall be erected in a neat and workmanlike manner on the foundations at the locations and elevations shown on the Drawings.
- D. All equipment sections and loose items shall be match-marked prior to shipping.
- E. For equipment such as pumping units, which require field alignment and connections, the CONTRACTOR shall provide the services of the manufacturer's qualified mechanic, millwright, or machinist, to align the pump and motor prior to making piping connections or anchoring the pump base. Alignment shall be as specified herein.

- F. The CONTRACTOR shall furnish oil and grease for initial operation and testing. The manufacturer and grades of oil and grease shall be in accordance with the recommendations of the equipment manufacturer.

### 3.05 ALIGNMENT

- A. Set equipment to dimensions shown on drawings. Dimensions shall be accurate to +/- 1/16 inch unless otherwise noted on the drawings. Wedges shall not be used for leveling, aligning, or supporting equipment.
- B. General Equipment Leveling: Non-rotating equipment shall be set level to +/- 1/16 inch per 10 foot length (.005 inch per foot) unless otherwise noted on the drawings. Shims shall be used unless equipment is furnished with leveling feet. Set shims flush with equipment baseplate edges. When grouting is required, equipment shall be shimmed to allow a minimum of one inch grout thickness. Grout shall cover shims at least 3 inches. Final level check shall be held for inspection and approval by ENGINEER before proceeding.
- C. Grouting
  1. Fill anchor bolt holes or sleeves with grout, after bolt alignment is proven, and prior to placing grout under equipment bases.
  2. Surface Preparation. Roughen surface by chipping, removing laitance, and unsound concrete. Clean area of all foreign material such as oil, grease, and scale. Saturate area with water at least 4 hours prior to grouting, removing excess water ponds.
  3. Application. Place grout after the equipment base has been set and its alignment and level have been approved. Form around the base, mix grout, and place in accordance with the grout manufacturers published instructions. Eliminate all air or water pockets beneath the base using a drag chain or rope.
  4. Finishing. Point the edges of the grout to form a smooth 45 degree slope.
  5. After grout has cured (not before 3 days after placement) paint exposed surfaces of grout with shellac.
  6. Level Verification. After grout has cured, and immediately prior to drive alignment, recheck equipment for level and plumb. Re-level and square as necessary. Hold final checks for inspection and approval by ENGINEER.
- D. Inspect for and remove all machining burrs or thread pulls in female holes on mating surfaces of mounting frame and machine feet.
- E. Inspect and clean equipment mounting base pads, feet, and frames to remove all grease, rust, paint and dirt.
- F. Assembled equipment shafts shall be set level to .0015 inches per foot of shaft length (+/- .0005 inches) up to a maximum of 0.015 inches for any length shaft unless the manufacturers requirements are more stringent or unless otherwise noted in the equipment specifications. Use the machined surfaces on which the equipment sets for the

base/mounting frame leveling plane. Use the machined shaft surface for equipment leveling plane.

- G. Sprocket and Sheave Alignment. Check shaft mounted components for face runout and eccentricity (outside diameter) runout by magnetically mounting a dial indicator on a stationary base and indicating over 360 degrees on a continuous machined surface at the outside diameter of the component. Maximum allowable total indicated face runout and eccentricity for sprockets and sheaves will be per ANSI Standard B29.1-1975.
- H. Belt tensioning. Set drive belt tension to manufacturer's specification for the belt type. Recheck alignment after drive tensioning.
- I. Thermal/Mechanical Growth. Thermal/mechanical growth corrections for driver and driven machines will be used in vertical and horizontal alignment where applicable. The equipment manufacturer will determine thermal/mechanical growth applicability for any machine and provide the correction offsets to be used.
- J. Rotating Shaft Alignment
  - 1. Fixtures will be set up on the driver and driven machine, machines shaft surfaces. Machined coupling hubs may be used only if there is no clearance to mount fixtures directly on the shafts.
  - 2. Primary alignment method for direct drive machines is when coupled. Uncoupled alignment will be used only when approved by the ENGINEER.
  - 3. Account for possible coupling flex by always rotating coupled machines in the same direction during alignment.
  - 4. Uncoupled machines must be connected so that both shafts turn together without relative motion during alignment.
  - 5. Indicator bar sag will be measured and included for each reverse indicator alignment setup.
  - 6. Reverse Dial Indicator. The final maximum allowable misalignment: vertical and horizontal from the desired targets of .000 inches (for a non-thermal growth machine) or from the given target readings (for a thermal growth machine) must meet BOTH of the following conditions simultaneously: 1/2 the final total indicator reading at each indicator will be no more than shown in the table below AND the final remaining correction at each machine foot be no more than .001 inches of required movement.

<b>Machine Speed (RPM)</b>	<b>Total Misalignment* (inches)</b>
Up to 1800	.002
1800 and greater	.001

*\*1/2 indicator reading*

### 3.06 FIELD TESTING

- A. All equipment shall be set, aligned and assembled in conformance with the manufacturer's drawings and instructions. Provide all necessary calibrated instruments to execute performance tests. Submit report certified by the pump manufacturer's representative.
- B. Preliminary Field Tests, Yellow Tag
  - 1. As soon as conditions permit, after the equipment has been secured in its permanent position, the CONTRACTOR shall:
    - a. Verify that the equipment is free from defects.
    - b. Check for alignment as specified herein.
    - c. Check for direction of rotation.
    - d. Check motor for no load current draw.
  - 2. CONTRACTOR shall flush all bearings, gear housings, etc., in accordance with the manufacturer's recommendations, to remove any foreign matter accumulated during shipment, storage or erection. Lubricants shall be added as required by the manufacturer's instructions.
  - 3. When the CONTRACTOR has demonstrated to the ENGINEER that the equipment is ready for operation, a yellow tag will be issued. The tag will be signed by the ENGINEER, or his assigned representative and attached to the equipment. The tag shall not be removed.
  - 4. Preliminary field tests, yellow tag, must be completed before equipment is subjected to final field tests, blue tag.
- C. Final Field Tests, Blue Tag
  - 1. Upon completion of the above, and at a time approved by the ENGINEER, the equipment will be tested by operating it as a unit with all related piping, ducting, electrical and controls, and other ancillary facilities.
  - 2. The equipment will be placed in continuous operation as prescribed or required and witnessed by the ENGINEER or his assigned representative and the CITY or his assigned representative.
  - 3. The tests shall prove that the equipment and appurtenances are properly installed, meet their operating cycles and are free from defects such as overheating, overloading, and undue vibration and noise. Operating field tests shall consist of the following:
    - a. Check equipment for excessive vibration and noise as specified herein.
    - b. Check motor current draw under load conditions. The rated motor nameplate current shall not be exceeded.

- c. Recheck alignment with dial indicators where applicable, after unit has run under load for a minimum of 24 hours.
- D. In addition to the above described field tests, any other tests specifically required by Division 11, the individual equipment Specifications, or by the manufacturer shall be performed.
- E. Until final field tests are acceptable to the ENGINEER, the CONTRACTOR shall make all necessary changes, readjustments and replacements at no additional cost to the CITY.
- F. Upon acceptance of the field tests, a blue tag will be issued. The tag will be signed by the ENGINEER and attached to the unit. The tag shall not be removed and no further construction work will be performed on the unit, except as required during start-up operations and directed by the ENGINEER.
- G. Defects which cannot be corrected by installation adjustments will be sufficient grounds for rejection of any equipment.
- H. All costs in connection with field testing of equipment such as lubricants, temporary instruments, labor, equipment, etc., shall be borne by the CONTRACTOR. Power, fuel, chemicals, water, etc. normally consumed by specific equipment shall be supplied by the CITY unless otherwise specified in the individual equipment specifications.
- I. The CONTRACTOR shall be fully responsible for the proper operation of equipment during tests and instruction periods and shall neither have nor make any claim for damage which may occur to equipment prior to the time when the CITY formally takes over the operation thereof.
- J. Field testing of electric motors shall be in accordance with Division 16.

### 3.07 VIBRATION TESTING

- A. Unless specified otherwise in the detailed equipment specifications, each pump, blower, compressor, motor or similar item of stationary rotating equipment having a rated power in excess of 40HP shall be tested after installation for acceptable vibration levels.
- B. Vibration testing shall be performed by an experienced factory-trained and authorized third-party analysis expert (not a sales representative) retained by the CONTRACTOR and approved by the ENGINEER. Each unit or pump system shall be tested separately without duplicate equipment running. All field testing shall be done in the presence of the ENGINEER. The ENGINEER shall be furnished with four (4) certified copies of vibration test data for each test performed.
- C. For systems with variable speed drives, tests shall be conducted at various speeds between maximum and minimum. For systems with two-speed drives, tests shall be conducted at both speeds. For systems with constant-speed drive, tests shall be conducted under various loading conditions as determined by the ENGINEER.
- D. All field vibration tests shall be performed with the equipment operating on the product for which it is intended, or a substitute acceptable to the ENGINEER.

- E. The term displacement, as used herein, shall mean total peak-to-peak movement of vibrating equipment, in mils; velocity or speed of the vibration cycle, measured in G's. Displacement and velocity shall be measured by suitable equipment equal to IRD Mechanalysis, Bentley, Nevada.
- E. Frequency of vibration, in cycles per minute (cpm), shall be determined when vibration exceeds specified levels or as otherwise necessary. Vibration shall be measured on the bearing housing, unless other locations are deemed necessary by the vibration analysis expert and ENGINEER.
- F. For all equipment tested, vibration shall be checked in the radial and axial directions. Unless otherwise specified elsewhere, axial vibration shall not exceed 0.1 in/sec; and radial vibration shall not exceed 0.2 in/sec. For pumps radial vibration shall not exceed that permitted by the Hydraulic Institute Standards except that, at vibration frequencies in excess of 8,000 cpm, the velocity shall not exceed 0.2 in/sec.
- G. Copies of test results shall be submitted to the ENGINEER for review. Should the vibration field test results exceed shop test results, the manufacturer's recommendations, or the limits specified herein, the CONTRACTOR shall correct the deficiencies within thirty (30) days. After corrections have been completed, the vibration testing shall be re-run and the results re-submitted to the ENGINEER for review.
- H. Noise or vibration in any rotating equipment which the ENGINEER determines to be excessive or damaging and falls outside of the acceptable limits for that particular piece of equipment, shall be cause for rejection.

### 3.08 FAILURE OF EQUIPMENT TO PERFORM

- A. Any defects in the equipment or failure to meet the guarantees or performance requirements of the Specifications shall be promptly corrected by the CONTRACTOR by replacements or otherwise.
- B. If the CONTRACTOR fails to make these corrections, or if the improved equipment shall fail again to meet the guarantees or specified requirements, the CITY, notwithstanding his having made partial payment for work and materials which have entered into the manufacture of said equipment, may reject said equipment and order the CONTRACTOR to remove it from the premises at the CONTRACTOR's expense.
- C. The CONTRACTOR shall then obtain specified equipment to meet the contract requirements or upon mutual agreement with the CITY, adjust the contract price to reflect not supplying the specific equipment item.
- D. In case the CITY rejects said equipment, then the CONTRACTOR hereby agrees to repay to the CITY all sums of money paid to him for said rejected equipment on progress certificates or otherwise on account of the lump sum prices herein specified.
- E. Upon receipt of said sums of money, the CITY will execute and deliver to the CONTRACTOR a bill of sale of all his rights, title, and interest in and to said rejected equipment; provided, however, that said equipment shall not be removed from the premises until the CITY obtains from other sources other equipment to take the place of that rejected.

- F. Said bill of sale shall not abrogate CITY's right to recover damages for delays, losses, or other conditions arising out of the basic contract.

### 3.09 PAINTING

- A. All surface preparation, shop painting, field repairs, finish painting, and other pertinent detailed painting specifications shall conform to applicable sections of Section 09900, Painting.
- B. All shop coatings shall be compatible with proposed field coatings.
- C. All inaccessible surfaces of the equipment, which normally require painting, shall be finished painted by the manufacturer. The equipment and motor shall be painted with a high quality epoxy polyamide semi-gloss coating specifically resistant to chemical, solvent, moisture, and acid environmental conditions, unless otherwise specified.
- D. Gears, bearing surfaces, and other unpainted surfaces shall be protected prior to shipment by a heavy covering of rust-preventive compound sprayed or hand applied which shall be maintained until the equipment is placed in operation. This coating shall be easily removable by a solvent.

### 3.10 WELDING

- A. The Equipment Manufacturer's shop welding procedures, welders, and welding operators shall be qualified and certified in accordance with the requirement of AWS D1.1 "Structural Welding Code - Steel" or AWS D1.2 "Structural Welding Code - Aluminum" of the American Welding Society, as applicable.
- B. The CONTRACTOR's welding procedures, welders, and welding operators shall be qualified and certified in accordance with the requirements of AWS D1.1 "Structural Welding Code - Steel" or AWS D1.2 "Structural Welding Code - Aluminum" of the American Welding Society, as applicable.
- C. The CONTRACTOR shall perform all field welding in conformance with the information shown on the Equipment Manufacturer's drawings regarding location, type, size, and length of all welds in accordance with "Standard Welding Symbols" AWS A2.0 of the American Welding Society, and special conditions, as shown by notes and details.

- END OF SECTION -

SECTION 11232 - FINAL CLARIFIER MECHANISM REPLACEMENT  
(ALTERNATE BID ITEMS)

PART 1 -- GENERAL

1.01 THE REQUIREMENT

- A. As part of the Base Bid, the CONTRACTOR shall perform all work necessary to bring Clarifier No. 3 to a fully operable system, including removal and re-installation of existing equipment, per the Contract Documents. At the CITY's option under Alternate Bid Items, the CONTRACTOR shall furnish, install, test, and place in acceptable operation, a new 135-foot diameter clarifier mechanism complete with sludge and scum collection system for existing Clarifier No. 3, as described herein and as shown on the Drawings.
- B. At the CITY's option, under Alternate Bid Item A-1, the equipment furnished for Clarifier No. 3 shall include: full-diameter walkway with handrails, center drive platform and grating, clarifier mechanism center assembly with drive unit, drive control, torque limiting system, control panels, stationary influent column (center column) with suitable upper inlet openings, neoprene seals, feedwell with steel base and seal around the center ring, center cage, sludge removal arms (rake arms) with blades and squeegees, sludge drawoff pipes, sludge collection drum with control valves, scum skimmers and supports, scum box, and scum spray system including spray nozzles, piping, and valve replacement, with solenoid valves and limit switches. All ferrous metals shall be coated in accordance with Section 09900. Materials specified in Section 11232 herein shall refer to the equipment furnished for a new 135-ft diameter clarifier mechanism, except where explicitly indicated in Paragraph 1.01(C) under Alternate Bid Item A-2.
- C. At the CITY's option, Alternative Bid Item A-2 is for complete clarifier mechanism replacement at Clarifier No. 3, as detailed in Alternative Bid Item A-1 (above); however, the following clarifier mechanism equipment components shall be furnished in 316 stainless steel: full-diameter truss walkway, center drive platform, center column and associated flanges and influent ports, feedwell and associated bottom plate and influent tubes, center cage, rake arms, rake blades, sludge collection drum, skimmer assemblies and scum box.
- D. At the CITY's option, under Alternate Bid Item A-3, the CONTRACTOR shall furnish and install new effluent weirs and scum baffles at Clarifier No. 3.
- E. At the CITY's option, under Alternate Bid Item A-4, the CONTRACTOR shall furnish and install new density current baffles at Clarifier No. 3.
- F. The clarifier equipment provided shall be the full and undivided responsibility of a single manufacturer who shall confirm compatibility of his equipment with the existing clarifier equipment and ensure complete coordination of all components and provide unit responsibility.
- G. Except where specifically indicated otherwise, all plates and structural steel shall have a minimum thickness of ¼" and coated as described in Division 9 and as shown on the Drawings and Shop Drawings. All fasteners for the mechanism shall be 316 stainless steel.



- H. All equipment installed in classified areas shall be suitable for the environment. Refer to electrical drawings for hazardous area classifications.

#### 1.02 RELATED WORK SPECIFIED ELSEWHERE

- A. Section 01010 – Summary of Work
- B. Section 01300 – Submittals
- C. Section 03732 – Concrete Repair
- D. Section 05500 – Metal Fabrications
- E. Section 06620 – Scum Baffles and Weir Plates
- F. Section 06650 – Density Current Baffles
- G. Section 07920 – Sealants and Caulking
- H. Section 09900 – Painting
- I. Section 11000 – Equipment General Provisions
- J. Section 15000 – Basic Mechanical Requirements
- K. Division 16 – Electrical
- L. Division 17 – Instrumentation

#### 1.03 GENERAL INFORMATION AND DESCRIPTION

- A. All parts of the mechanism furnished shall be amply designed and constructed for the maximum stresses occurring during fabrication, erection and continuous operation. All materials shall be new and both workmanship and materials shall be of the very best quality, entirely suitable for the service to which the units are to be subjected and shall conform to all applicable sections of these specifications. All parts of duplicate equipment shall be interchangeable without modification. Manufacturer's design shall accommodate all the requirements of these specifications.
- B. Clarifier No. 3 is of the center column bottom inlet feed and peripheral overflow type with a central driving mechanism, which supports and rotates a center cage with two rakes attached.
- C. The equipment shall be of sufficient structural and mechanical strength to sweep in the two-inch grout layer on the tank bottom under its own power. (This does not mean utilizing the clarifier arm for spreading the concrete.) The mechanism shall be arranged for scraping blades and sludge withdrawal pipes along the length of the rake arms for rapid removal of sludge. Deflector blades with squeegees shall be attached to the bottom of the arms in a "V" notch pattern to guide the sludge to the openings of the withdrawal pipes

along the arms and will sweep the entire floor on each revolution of the collector arm as shown on the drawings.

- D. The clarifier mechanism shall be designed and furnished with no chains, sprockets, bearings or operating mechanism below the liquid surface or in contact with the liquid. Peripheral or traction drive mechanisms will not be regarded as equal to the center drive mechanisms specified. Major pieces of equipment, such as the drive and center well are to be assembled in the shop to ensure proper fitting of parts, marked with erection marks and knocked down for shipment.

#### 1.04 MANUFACTURERS

- A. The materials covered by the Specifications are intended to be standard equipment of proven reliability and as manufactured by reputable manufacturers having experience in the production of such equipment. The equipment furnished shall be designed, constructed, and installed in accordance with the best practices and methods and shall operate satisfactorily when installed as shown on the Drawings and operated per manufacturers recommendations.
- B. The clarifier mechanism shall be as manufactured by Ovivo USA, Westech Engineering, or equal.

#### 1.05 SUBMITTALS

- A. The CONTRACTOR shall submit shop drawings and Operation and Maintenance Instructions and other information as specified in accordance with Section entitled, "Submittals." Additional required information should include: the horsepower, voltage, and rotative speed of the motor and the total weight of the equipment plus the approximate weight of the shipped materials, and hydraulic calculations for the rapid sludge withdrawal system. Shop Drawings shall also include complete erection, installation and adjustment instructions and recommendations, and detailed test procedures for the field testing specified herein.

#### 1.06 OPERATION AND MAINTENANCE MANUALS

- A. The CONTRACTOR shall submit operation and maintenance manuals in accordance with the procedures and requirements set forth in Section entitled, "Submittals."
- B. Two copies of a preliminary O&M manual shall be included in the shop drawings submittal. Without inclusion of these manuals, the submittal will be considered incomplete and will be returned without review.

#### 1.07 SERVICES OF MANUFACTURER'S REPRESENTATIVE

- A. The CONTRACTOR shall provide the services of a qualified manufacturer's technical representative who shall adequately supervise the installation and testing of all equipment furnished under this Section and instruct the CITY's operating personnel in its maintenance and operation as outlined in the General Conditions and Division 1. The services of the manufacturer's representative shall be provided for a period of not less than four days as follows:

1. One two-day trip during the installation of Clarifier 3.
  2. One one-day trip for start-up and training of CITY staff.
  3. One trip of one day after acceptance of the equipment, during the guarantee period, at CITY's request.
- B. Any additional time required to achieve successful installation and operation shall be at the expense of the CONTRACTOR.

#### 1.08 TOOLS, SUPPLIES AND SPARE PARTS

- A. The equipment manufacturer shall furnish all special tools necessary to disassemble, service, repair, lubricate, and adjust the equipment. A complete list of tools and instructions for their use recommended by the manufacturer shall be submitted with the Shop Drawings.
- B. The CONTRACTOR shall furnish a one-year's supply of all recommended lubricating oils and grease.
- C. Spare parts shall be furnished as recommended by the manufacturer and shall be identical to and interchangeable with original parts. As a minimum, the following spare parts shall be provided:
- a. One (1) set of neoprene seals for Clarifier No. 3.

#### 1.09 WELDING

- A. The Equipment Manufacturer's shop welding procedures, welders and welding operators shall be qualified and certified in accordance with the requirement of AWS D1.1 "Welding In Building Construction" of the American Welding Society.
- B. The Equipment Manufacturer's shop drawings shall clearly show complete information regarding location, type, size and length of all welds in accordance with "Standard Welding Symbols" AWS A2.0 of the American Welding Society. Special conditions shall be fully explained by notes of details.
- C. The CONTRACTOR's welding procedures, welders and welding operators shall be qualified and certified in accordance with the requirements of AWS D1.1 "Welding in Building Construction" of the American Welding Society.
- D. The CONTRACTOR shall perform all field welding in conformance with the information shown on the Equipment Manufacturer's drawings regarding location, type size and length of all welds in accordance with "Standard Welding Symbols" AWS A2.0 of the American Welding Society, and special conditions as shown by notes and details.

PART 2 -- PRODUCTS

2.01 GENERAL

- A. The design criteria of equipment to be furnished and installed under this section are as noted on Table 11232-1:

**Table 11232-1**

<b>Item</b>	<b>Clarifier Design Criteria</b>	
	<b>Clarifier No. 3</b>	
Number of Units	1	
Identification Numbers		
Inside Tank Diameter, ft	135	
Side Water Depth, ft	14.2	
Tank Bottom Slope, in/ft	1/16	
<u>Center Drive Mechanism:</u>		
Continuous Torque, ft-lb	75,000	
Design Torque (motor shutdown), ft-lb	75,000	
Momentary Torque, (peak) ft-lb	150,000	
Rake Arms Tip Speed, fpm (Max.)	10	
Cage and Arm Design, ft-lb	150,000	
Motor Horsepower Minimum, Hp	1.5	
Hydraulic Capacity of Rapid Sludge Pick Up System (gpm/tank of 0.5 to 3.0% pure oxygen activated sludge)	6,600	

- B. The manufacturer shall furnish calculations and a written statement certifying that the drive selected meets the output torque including all gears and pinions in the drive train and the other requirements specified herein.
- C. Structural steel used in fabricated parts shall conform to requirements of "Standard Specifications for Steel for Bridges and Buildings" ASTM Designation A36. All shop welding shall conform to the latest standards of the American Welding Society.
- D. All anchor bolts, washers, clips, clamps and fasteners of any type shall be constructed of Type 316 Stainless Steel.

2.02 CENTER COLUMN AND CAGE

- A. A cylindrical steel center column shall be furnished for mounting over the influent port at the center of the tank floor to support the mechanism with no torque transmitted to the walkway. The center column shall have a minimum inside diameter of 54 inches with a port area of adequate size to secure a low inlet-velocity into the influent well. Anchor bolts for Clarifier No. 3 shall be adhesive type. The manufacturer shall furnish the sufficient number of anchor bolts required for the torque load and for securing the center column on the concrete floor. Steel thickness of column shall be a minimum of 1/2 inch.

- B. Two sets of ports shall be included at the upper end. One set of upper ports shall convey the fresh sludge from the overflow boxes to the central discharge pipe. The lower set of ports shall diffuse the flow entering the tank and insure low velocity into the influent well. The lower ports total opening area shall be a minimum of 135 percent of the influent pipe cross sectional area. Upper and lower ports shall be separated by a neoprene seal with steel backing ring.
- C. A steel center cage shall be bolted to the internal gear and shall be sufficiently strong and stiff to support and rotate the rake arms.

### 2.03 CENTER DRIVE MECHANISM

- A. The center drive mechanism shall be designed for the specified design torque on the internal gear without excessive wear. The mechanism shall be capable of developing the specified momentary torque on the internal gear without failure of any part.
- B. The center drive mechanism shall consist of a turntable base mounted on the center column, a ball race, a turntable top with internal gear with pinion, and cycloidal or worm gear reduction unit. The turntable base and top shall be heat-treated, high grade Type GC, ASTM A48 Mechanite cast iron alloy, ASTM A36 steel, or acceptable equal for Alternate Bid Item A-1 and ASTM A276 for Alternate Bid Item A-2. The top of the turntable base shall provide adequate and convenient access to the drive mechanisms for proper maintenance.
- C. The turntable base shall be bolted to the center column and be designed to support the internal gear with the rotating mechanism and the walkway. Welded steel construction will be permitted. The turntable base shall have an annular raceway to contain balls upon which the internal gear rotates. The ball race shall have a minimum diameter of 65 inches to assure stability without the necessity of underwater guide shoes.
- D. The ball race shall contain a minimum 1-1/2 inch diameter balls made of chrome alloy steel AFBMA Grade 500. The balls shall bear vertically and horizontally on four renewable steel liner strips fitted into the turntable base and internal gear or utilize full contour raceways. The strip liner design shall be such that the B-10 life of the liner is a minimum of 20 years based on the specified mechanism speed and a uniformly distributed load on the rotating mechanism. Drives using integral bearing and gear assemblies must have replaceable bearing balls and liners, if used, independent of the gear, without removing the gear.
- E. The balls shall run in an oil bath or be grease packed and protected by suitable seals. A sight gauge shall be provided for observation of oil level. All oil dams in the drive shall be full sidewall integral with the base and have a minimum of 4-inch deep oil storage and condensation reservoir below the bottom of the bearing assembly. Housing shall be designed such that gears and bearings are properly lubricated. For spur gear teeth, which are not fully submerged in oil, the tooth mesh shall be designed to force lubricant to the upper portion of the tooth face.
- F. An oil sight glass shall be provided for the upper and lower oil reservoirs. Readily accessible lubricant fill and drainpipes of Type 316L Stainless Steel fittings shall be provided. Accessibility shall be achieved without removing or lifting floor plate sections or

covers. Lubricant systems that require auxiliary oil pumps or recirculating systems will not be acceptable.

- G. The internal gear shall also be machined from a high-grade cast iron or other approved metallurgy and shall be designed to support the center cage and rake arms. The internal gear shall be driven by a heat treated metal pinion and shaft keyed to the drive unit primary reduction unit mounted on the turntable base.
- H. At continuous torque, the gear teeth shall not be stressed to more than 30 percent of their yield strength.
- I. The drive head bearing shall be related for the total rotating weight. The bearing shall have minimum B-10 life rating of 20 years.

#### 2.04 DRIVE UNIT

- A. The drive unit shall be secured to the turntable base and shall consist of a worm, and worm gear or cycloidal speed reducer, and a pinion mounted in a cast Mechanite metal or cast iron housing with a removable steel cover plate. Directly coupled cycloidal reducers shall also be acceptable.
- B. The worm and worm shaft shall be cast as an integral unit and shall be heat treated steel (ASTM 4142N) or alloy steel (AISI 8620 or AISI 4140/42 H) with the worm threads surface hardened and finish ground or carbonized, hardened, ductile iron minimum Grade 80. The worm gear shall consist of a worm gear rim and hub. The worm gear rim shall be a cast Mechanite metal type GM60 (ASTM A48) or centrifugally cast bronze. The worm gear rim shall be replaceable without disassembly of bearings.
- C. The worm and worm gear shall operate in an oil bath. A sight gauge shall be provided for observation of the oil level.
- D. The pinion and pinion shaft shall be cast as an integral unit and shall be alloyed nodular iron, Grade 80-60-04 (ASTM A536) heat-treated and with hardened teeth or 41L47 AISI forged steel 220-266 BHN. The pinion shaft shall be keyed to the worm gear spider and the pinion shall mesh with and rotate the internal gear.
- E. Bearings supporting the worm, worm gear and the pinion shall be precision tapered roller bearings and shall operate in an oil bath. The lower pinion shaft bearing shall be grease lubricated or the bearings, including the shaft bearings shall operate in an oil bath. An acceptable alternative for the bearings supporting the worm, worm gear and pinion, shall be a deep groove ball bearing SKF-62 or 63 for worm input, upper pinion, angular contact ball bearing SKF-73 for the worm thrust bearing, and cylindrical roller bearings SKF-N3 for the lower pinion. The lower pinion-bearing pocket shall not be lower than the oil dam of the main gear base. All oil dams in the drive shall be full sidewall integral with the base and have a minimum of four-inch deep oil storage and condensation reservoir below the bottom of the bearing assembly. Housing shall be designed such that gears and bearings are oil lubricated.
- F. The complete drive shall be designed for the continuous torque specified based upon 24 hour per day over 20 years using two criteria established per 2001-C95 spur gear and pinion and AGMA 440.02 worm and worm gear design.

- G. The cycloidal speed reducer shall be directly connected to the motor without the use of chains or v-belts, and shall be keyed to the pinion. The main ring gear of the cycloidal drive shall be made of high carbon chromium bearing steel. The speed reducer gearing shall be manufactured to AGMA standards and have a service factor of 1.25.

## 2.05 ELECTRIC MOTORS

- A. The clarifier drive unit is driven by a drive motor. The drive motor shall be minimum 1 ½ hp. The motor shall be TEFC chemical service and shall be 460 V, 60 Hz, 3 phases A.C. Motor shall comply with the applicable portions of Section entitled, "Electric Motors."

## 2.06 OVERLOAD DEVICES

- A. The CONTRACTOR shall furnish and install new overload device as part of the clarifier drive unit replacement. The overload device shall be actuated by the shaft and shall indicate the load on the center drive mechanism at all times. The overload device shall have a minimum of two torque switches, one adjusted to actuate when the load on the mechanism approaches an overload; the other to open the motor circuit when an excessive overload occurs. The two torque switches shall be preset at the factory to provide remote indication at 85 percent of the design torque and to stop the motor at the momentary torque. Torque switches shall be DPDT, 120 VAC, 5 amp, continuous rating.

## 2.07 INFLUENT FEEDWELL

- A. The influent well at Clarifier No. 3 shall be 26 feet in diameter and project 7 feet below the water level and 6 inches above the maximum clarifier water level and shall be made of minimum 1/4-inch steel plate with stiffening angles and provided with at least eight 4" x 16" baffled slots equally spaced at water level to permit escape of floating material. Each slot shall be provided with steel plate and connectors to permit blocking of the openings. The bottom of the influent feedwell shall be supplied with a solid reinforced steel bottom and a seal around the center column similar to the seal specified for the rotating sludge discharge well. The influent feedwell shall be coated as described in Division 9.
- B. The feedwell shall be equipped with a scum wedge skimmer assembly. The scum wedge skimmer shall include a rotating skimmer arm fixed between the rotating feedwell and cage tangentially in front of a scum port just in front of the rotating skimmer. The cage shall be fitted with a fixed support constructed of pipe and angle frame with a minimum 12-inch skimmer skirt. Scum shall be wedged along the skimmer bar and forced out into the area between baffle and feedwell.

## 2.08 ROTATING RAKE ARMS

- A. Two structural steel arms of box truss construction conforming to the slope of the tank floor shall be rigidly bolted to the center cage without the use of supporting guy or tie rods and shall be provided with 1/4-inch steel bolted rake blades to scrape the settled sludge on the tank bottom to the sludge drawoff pipes.
- B. Rake arms for Clarifier No. 3 shall be shipped in two pieces and field assembled. Blades may be field mounted. The blade setting shall be identical for each arm with the blades so spaced in a "V" notch pattern such that each pickup pipe removes sludge from equal

surface areas of the tank bottom and that the entire tank bottom is scraped twice for each revolution of the mechanism. Adjustable stainless steel squeegees shall be furnished for all blades and they shall project 1-1/2 inches below the bottom of the blade and shall be secured by Type 316 Stainless Steel bolts and nuts.

- C. Dissimilar materials shall be properly isolated. The rotating rake arms shall be coated as described in Division 9.

## 2.09 RAPID SLUDGE WITHDRAWAL COMPONENTS

- A. Clarifier No. 3 shall be provided with six 10-inch diameter withdrawal pipes on each rake arm. Sludge withdrawal pipes shall be Schedule 80 PVC type 1, grade 1 ASTM 3034. Elbows with fair curves for change of direction shall be provided as required. PVC pipe shall be arranged for easy assembly with minimum trimming. For Clarifier No. 3, the maximum total sludge returned shall be 6,600 gpm. The withdrawal pipes shall be attached to the rake arms at their lower end by means of Type 316 Stainless Steel clamps and shall pass through the arms and vertically upward to the rotating sludge discharge well.

## 2.10 ROTATING SLUDGE DISCHARGE WELL (SLUDGE COLLECTION DRUM)

- A. A rotating sludge discharge well (sludge collection drum) shall be provided and shall be constructed of 1/4-inch steel plate, assembled around the center cage and extend through the cage to the center column. A suitable neoprene seal shall be provided between the rotating discharge well and the stationary center column. The seal elements shall provide easy adjustment for assembly and maintenance. The seal shall accommodate eccentric vertical variation in alignment. The main seal element shall be constructed of carbon steel ring welded to the center column with a continuous carbon steel ring welded to the sludge wet well. A hard rubber seal, studded to the sludge box well ring shall be installed across the seal opening. The top of the box shall be the same height as the influent feedwell. The discharge well shall be centrally located within the influent well and shall be arranged to convey the sludge from the withdrawal pipes to the central discharge pipe. The discharge well shall be coated as described in Division 9.

## 2.11 SLUDGE OVERFLOW CONTROL DEVICE

- A. The upper end of each sludge withdrawal pipe shall be provided with an overflow control device in the discharge well. The control device shall be adjustable to positively control the flow of sludge from each withdrawal pipe. The overflow control device shall essentially be an adjustable port and shall consist of a stationary inner pipe and a rotating outer pipe. The inner pipe shall be flanged at the lower end for mounting on the bottom of the discharge well and for bolting to the flange of sludge withdrawal pipe and shall be provided with a vertical rectangular slot. The outer pipe shall fit snugly over the inner pipe and shall be provided with a trapezoidal opening. The openings shall be superimposed over one another and the effective opening area shall be variable by rotating the outer pipe. An indicator shall be provided for each overflow control for determining the effective opening in the device. The outer pipe shall be removable in order to have the full inner pipe diameter clear for back flushing when required. Each control device shall be fabricated from ASTM D3034 PVC piping, with a minimum 3/8-inch thick top and bottom flanges. The devices shall be assembled using approved PVC welding. Solvent welded assembled



is not acceptable. All mounting clips and bolts for the sludge control devices shall be 316 stainless steel.

- B. The ports shall be operated submerged up to the maximum flow of 6,600 gpm/tank for Clarifier No. 3 so that flow rate may be controlled by differential water level by throttling the return sludge discharge line from the tank. A tool for adjusting the overflow control devices from the walkway shall be provided. Overflow control devices using a telescopic valve arrangement are not acceptable. A maximum head loss from the clarifier water surface at maximum sludge flow shall not exceed ten inches in the sludge box.

## 2.12 SCUM SKIMMERS, SKIMMER SUPPORTS AND SCUM BOXES

- A. The manufacturer shall furnish skimmers and compatible scum box for Clarifier No. 3. Clarifier No. 3 shall be furnished with two skimming devices to collect the floating scum along the interior edge of the collection trough where it shall be automatically deposited in one scum box. Each of the two skimming devices shall be supported from each rake arm and shall consist of a 1/2-inch thick neoprene skimming blade (approximately 72" x 18") installed on the fixed skimmer arm with a 2-inch diameter stainless steel pipe section.
- B. One 6-foot wide scum box for Clarifier No. 3 shall be adequately supported from the effluent trough wall and connected to the scum drain system through an 8-inch diameter scum pipe as shown on the Drawings. The box shall be made of welded 1/4-inch steel plate, to serve as an integral section of the tanks scum baffle. The assembly shall have a scum trough, vertical steel sides, sloping ramp, and 8-inch diameter straight pipe stub for connection of a flexible connector to interface with scum outlet piping.

## 2.13 ACCESS BRIDGE AND PLATFORM

- A. Clarifier No. 3 shall have an access bridge spanning the full diameter of the tank, as shown on the Drawings. At the center of the clarifier mechanism, a platform with hand railing and kick plate shall be provided. The center drive platform shall have removable 1-1/2 inch I-bar aluminum grating for access to the drive mechanism.
- B. The walkway support structural members shall be all welded, truss construction, with diagonal and cross bracing as necessary, and shall be hot-dipped galvanized after fabrication. The flat portion of the channel shall be located on the outface of the walkway to support handrails, light poles and appurtenances. Walkways shall be aluminum checkered plate.
- C. The access bridge and platform shall be designed for a live load of 100 pounds per square foot and a maximum deflection of 1/360. The walkways shall be a minimum of three feet wide.
- D. The CONTRACTOR shall design and furnish materials for the walkway connection to the outer concrete wall. The connection shall provide for expansion and contraction of the walkway from temperature by use of stainless steel UHMW-PE self-lubricating plate bearings. A means shall be provided to prevent lateral movement of the bridge at the outer wall. Walkways shall be designed to support light poles and fixtures as shown on the Drawings. The 10-inch by 10-inch (minimum) 90 degree light pole supports shall be supplied and installed by the clarifier Supplier, subject to review and comment of the ENGINEER.

- E. Drive platforms shall consist of a steel frame with 1-1/2 inch I-bar aluminum grating designed to support a live load of 100 pounds per square foot and provided with stiffener angles as required to meet the design load with a maximum deflection of l/240.
- F. Handrailing, checkered plates and kick plates shall be aluminum as specified in the Division entitled "Metals." Metallic steps, as required to meet local code requirements, shall be furnished between the structure and the access bridge, as required.
- G. All dissimilar metals shall be properly isolated.

2.14 STRUCTURAL STEEL

- A. All material used in fabricating structural steel shall be new and undamaged. All materials shall conform to applicable provisions of the AISC Specifications for the design and fabrication of structural steel, AWS Welding Specification and to pertinent ASTM Standard Specification including the following:

<b>Material</b>	<b>ASTM Standard Specifications For</b>	<b>ASTM Designation</b>
Structural steel not welded	Steel for bridges and buildings	A-36
Welded structural Steel	Structural steel for welding	A-36
Cast iron	Grey iron castings	A-48
Machine bolts	Low carbon steel fasteners	Grade 5 A537 High Strength
316 Stainless steel	Plates and sheets	ASTM A167 or A666 Grade A
316 Stainless steel	Structural shapes	ASTM A276

2.15 EFFLUENT WEIR SCUM BAFFLES AND DENSITY BAFFLES

- A. Comply with requirements set forth in Division 6.

2.16 SPRAY NOZZLES

- A. Spray nozzles shall be constructed of Type 316 Stainless Steel, operate at a pressure of 10 psi and connections shall be 3/8-inch NPT. All nozzles shall be capable of passing a maximum 1/8-inch diameter sphere. Nozzles shall be manufactured by Spraying Systems Co., Bete, Inc., Bex, Lechler, or equal.
- B. Nozzle replacement shall be of the same quantity and location as existing nozzles. Nozzles shall consist of the following types.

<b>Description</b>	<b>Spraying Systems Model No.</b>
Surface Skimmer	3/8 K-40
Scum Boxes	3/8 GG-25

- B. All spray piping, including miscellaneous valves, elbows, unions, drop pipe for nozzles, etc., shall be replaced in-kind at Clarifier No. 3, to the work area limits indicated on the drawings.

## 2.17 CONTROL PANEL

- A. The Clarifier Supplier shall furnish an electrical control panel for Clarifier No. 3 to be mounted on the access bridge handrail, at the location of the existing control panel to be removed and replaced. The panel shall conform to all applicable requirements of Divisions 16 and 17 and the Drawings.
- B. The panel shall include a disconnect switch, Start-Stop and Reset pushbuttons for the rake drive and equipment. Panel shall also include HOA selector switches and reset cycle timers for the scum spray controls. Refer to elementary control schematics for additional controls and equipment requirements.
- C. The panel shall be housed in a NEMA 4X rated 316L stainless steel enclosure and shall be constructed by a UL508A approved panel shop, and shall be furnished with a U.L Label. The panel shall have a hinged and gasketed door. Door latches shall be all stainless steel, fast operating clamp assemblies that do not require bolts or screws to secure.
- D. The panel components shall be connected to the MCC as shown on the Drawings.
- E. Provide "dry contact" relay outputs for the digital (discrete) outputs signals shown on the Instrumentation Drawings.
- F. Control Operator Requirements:
  - 1. Control operators such as pushbuttons (PB), selector switches (SS), and pilot lights (PL) shall be Cutler-Hammer/Westinghouse Type E34, Square D Company Type SK, or equal. Control operators shall be 30.5 mm, round, heavy duty, oil tight NEMA 4X corrosion resistant.
  - 2. Pushbuttons shall be non-illuminated, spring release type. Pushbuttons shall include a full guard. Panic stop/alarm pushbuttons shall be red mushroom type with manual-pull release. Selector switches shall be non-illuminated, maintained contact type. Pilot lights shall be of the proper control voltage, LED type with lens colors as indicated on the elementary control diagrams.
  - 3. Control operators shall have legend plates as specified herein, indicated on the Drawings, or otherwise directed by the Engineer. Legend plates shall be plastic, black field (background) with white lettering. Engraved nameplates shall be securely fastened above each control operator. If adequate space is not available, the nameplate shall be mounted below the operator.
  - 4. Control operators for all equipment shall be as specified herein and of the same type and manufacturer unless otherwise specified or indicated on the Drawings.

5. Alarm horns shall be general-purpose type, flush panel mount, suitable for weatherproof service, as required. Volume shall be adjustable.

## 2.18 LIMIT SWITCHES AND SCUM SPRAY CONTROLS

- A. Limit switches shall be furnished and installed on Clarifier No. 3 to indicate position of the clarifier skimmer mechanism relative to the scum box. Switches shall be form Z type, Model 43-100 D as manufactured by General Equipment & Manufacturing Co., or equal. Case shall be hermetically sealed, epoxy coated brass. Switches shall be furnished with mounting brackets and hardware designed to detect passage of the clarifier scum mechanism.
- B. Switch contacts shall be SPDT, 120 VAC, 10 amp, continuous rating.
- C. Each switch shall reset and actuate an adjustable reset cycle timer which shall energize a 120 volt solenoid valve on the scum box spray header and de-energize the solenoid valves after an adjustable time delay (0 - 10 minutes).

## 2.19 SCUM SPRAY SOLENOID

- A. Scum spray solenoids shall be furnished for Clarifier No. 3 by the Clarifier Supplier. Scum spray solenoids shall be 120 VAC, energize to open, spring close, heavy duty, with hand-actuated manual override capability in NEMA 4X enclosure and shall be coordinated with scum spray piping and nozzles. Solenoid valves shall be mounted complete in place and wired to the scum spray controls and control panel.

## PART 3 -- INSTALLATION

### 3.01 ERECTION

- A. All equipment shall be erected by the CONTRACTOR in accordance with the manufacturer's drawings and instructions.
- B. Joints between weir plates and concrete and butting weir plates shall be reasonably tight. The CONTRACTOR shall caulk all joints with sealant material as specified in the Section entitled "Joint Fillers, Sealants and Caulking".
- C. Weirs and scum baffles shall be installed in full accordance with the manufacturer's recommendations by mechanics skilled in the installation of this type of work.

### 3.02 PAINTING

- A. New equipment shall be sandblasted and shop primed, in accordance with Section 09900 – Painting.
- B. Surfaces shall be finish painted in the field, in compliance with Section 09900 – Painting.

### 3.03 TESTING

- A. Field testing of torque capability on the collection mechanisms shall be performed as

follows:

1. Static Torque Test

- a. The purpose of the test shall be to verify the structural integrity of the mechanism and drive. Manufacturer shall provide a qualified service person to supervise tests.
- b. The clarifier mechanism shall be field torque tested. The testing shall be carried out under the supervision of the equipment manufacturer before the mechanisms are accepted and placed into operation.
- c. The torque test shall consist of securing the rake arms by cables to anchor bolts installed by the CONTRACTOR in the tank floor at locations recommended by the manufacturer and accepted by the ENGINEER. A torque load shall be applied to the scraper arm by means of a ratchet lever and cylinder connected to the cable assembly.
- d. The magnitude of the applied load shall be measured by calculating the torque from the distance of the line of action of each cable to the centerline of the mechanism. Readings shall be taken at 50 percent, 85 percent, and 100 percent of design torque value. The test load shall be applied and noted on the torque overload device.
- e. The manufacturer's serviceman shall certify that the alarm and motor cut-out torque of the drives as calibrated in the manufacturer's shop are in proper operation to shut down the unit as specified.
- f. All equipment required for the test shall be provided by the CONTRACTOR.
- g. Anchor bolts shall be removed and concrete repaired in accordance with Division 3, at the successful completion of the test.

2. Dynamic Torque Test

- a. Following completion of the static torque test as outlined on the manufacturer's drawings, a dynamic test is to be performed.
- b. The drive control torque cut-out switch must be verified as operational before test begins. This test is only to be performed under the supervision of the manufacturer's representative.
- c. Load static test cables equally at 200 pound load.
- d. Back off machine to allow three feet of arm rotation before arms begin loading. Cable lengths must not be altered after loading in order to provide equal loading to arms. Allow drive torque control to sound alarm and shut down motor. Note switch settings for alarm actuation and motor shutdown.
- e. Start machine and allow arms to load up test cables.

- f. Back off arms by letting off evenly of test cables.
- g. If the torque tests fail, the test shall be repeated at no additional cost to the CITY.

- END OF SECTION -

**DIVISION 12 – FURNISHINGS**

**NOT USED**

**DIVISION 13 – SPECIAL CONSTRUCTION**

**NOT USED**



**DIVISION 14 – CONVEYING SYSTEMS**

**NOT USED**

**DIVISION 15 – MECHANICAL CONSTRUCTION**

## SECTION 15000 - BASIC MECHANICAL REQUIREMENTS

### PART 1 -- GENERAL

#### 1.01 THE REQUIREMENT

- A. The CONTRACTOR shall furnish and install to the required line and grade, all piping together with all fittings and appurtenances, required for a complete installation. All piping located outside the face of structures or building foundations and all piping embedded in concrete within a structure or foundation shall be considered exterior piping.
- B. The CONTRACTOR shall furnish and install fittings, couplings, connections, sleeves, adapters, harness rods and closure pieces as required to connect pipelines of dissimilar materials and/or sizes herein included under this Section and other concurrent Contracts for a complete installation.
- C. The CONTRACTOR shall furnish all labor, materials, equipment, tools, and services required for the furnishing, installation and testing of all piping as shown on the Drawings, specified in this Section and required for the Work. Piping shall be furnished and installed of the material, sizes, classes, and at the locations shown on the Drawings and/or designated in this Section. Piping shall include all fittings, adapter pieces, couplings, closure pieces, harnessing rods, hardware, bolts, gaskets, wall sleeves, wall pipes, hangers, supports, and other associated appurtenances for required connections to equipment, valves, or structures for a complete installation.
- D. Piping assemblies under 4-inch size shall be generally supported on walls and ceilings, unless otherwise shown on the Drawings or ordered by the ENGINEER, being kept clear of openings and positioned above "headroom" space. Where practical, such piping shall be run in neat clusters, plumb and level along walls, and parallel to overhead beams.
- E. The CONTRACTOR shall provide taps on piping where required or shown on the Drawings. Where pipe or fitting wall thicknesses are insufficient to provide the required number of threads, a boss or pipe saddle shall be installed.
- F. The work shall include, but not be limited to, the following:
  - 1. Connections to existing pipelines.
  - 2. Test excavations necessary to locate or verify existing pipe and appurtenances.
  - 3. Installation of all new pipe and materials required for a complete installation.
  - 4. Cleaning, testing and disinfecting as required.

#### 1.02 RELATED WORK SPECIFIED ELSEWHERE

- A. Division 1, General Requirements
- B. Division 2, Sitework

- C. Division 5, Metals
- D. Division 9, Finishes
- E. Division 11, Equipment
- F. Division 16, Electrical

#### 1.03 MANUFACTURERS

- A. The City of Hollywood requires all ductile iron pipe and fittings to be manufactured in America.

#### 1.04 MATERIAL CERTIFICATION AND SHOP DRAWINGS

- A. The CONTRACTOR shall furnish to the CITY (through the ENGINEER) a Material Certification stating that the pipe materials and specials furnished under this Section conform to all applicable provisions of the corresponding Specifications. Specifically, the Certification shall state compliance with the applicable standards (ASTM, AWWA, etc.) for fabrication and testing.
- B. Shop Drawings for major piping (2-inches in diameter and greater) shall be prepared and submitted in accordance with Section 01300 – Submittals. In addition to the requirements of Section 01300 – Submittals, the CONTRACTOR shall submit laying schedules and detailed Drawings in plan and profile for all piping as specified and shown on the Drawings.
- C. Shop Drawings shall include, but not be limited to, complete piping layout, pipe material, sizes, class, locations, necessary dimensions, elevations, supports, hanger details, pipe joints, and the details of fittings including methods of joint restraint. No fabrication or installation shall begin until Shop Drawings are approved by the ENGINEER.

### PART 2 -- PRODUCTS

#### 2.01 GENERAL

- A. All specials and every length of pipe shall be marked with the manufacturer's name or trademark, size, class, and the date of manufacture. Special care in handling shall be exercised during delivery, distribution, and storage of pipe to avoid damage and unnecessary stresses. Damaged pipe will be rejected and shall be replaced at the CONTRACTOR's expense. Pipe and specials stored prior to use shall be stored in such a manner as to keep the interior free from dirt and foreign matter.
- B. Testing of pipe before installation shall be as described in the corresponding ASTM or AWWA Specifications and in the applicable standard specifications listed in the following sections. Testing after the pipe is installed shall be as specified in Section 3.09.
- C. Joints in piping shall be of the type as specified in the appropriate Piping System Schedule in Section 15390, Schedules.

- D. ALL BURIED EXTERIOR PIPING SHALL HAVE RESTRAINED JOINTS FOR THRUST PROTECTION UNLESS OTHERWISE SPECIFIED OR SHOWN ON THE DRAWINGS. ALL EXPOSED EXTERIOR PIPING SHALL HAVE FLANGED JOINTS, UNLESS OTHERWISE SPECIFIED OR SHOWN ON THE DRAWINGS.
- E. The CONTRACTOR shall verify existing above ground and buried piping tie-in connections before fabricating new piping assemblies. The CONTRACTOR shall verify size, type, and location of all existing buried piping and appurtenances by excavating test pits as required of all buried connections and crossings which may affect the CONTRACTOR's work prior to ordering pipe and fittings to determine sufficient information for ordering materials. The CONTRACTOR shall take whatever measurements that are required to complete the work as shown or specified.
- F. Before setting wall sleeves, pipes, castings and pipes to be cast in place, the CONTRACTOR shall check the Drawings and equipment manufacturer's drawings which may have a direct bearing on the pipe locations.
- G. Piping shall be attached to pumps, valves, equipment, etc., in accordance with the respective manufacturers' recommendations. This includes the use of flexible connectors as required.
- H. All changes in directions or elevations shall be made with fittings, unless otherwise shown.

2.02 WALL PIPES

- A. Where wall sleeves or wall pipes occur in walls that are continuously wet on one or both sides, they shall have water stop flanges at the center of the casting or as shown on the Drawings. Ends of wall pipes shall be flange, mechanical joint, plain end, or bell as shown on the Drawings, or as required for connection to the piping. Wall pipes shall be of the same material as the piping that they are connected to. If welded waterstop flanges are employed, welds shall be 360 degree continuous on both sides of flange. Unless otherwise shown on the Drawings, waterstop flanges shall conform to the minimum dimensions shown below:

<u>Pipe Size</u>	<u>Waterstop Flange Diameter</u>	<u>Waterstop Flange Thickness</u>
4" - 12"	OD + 3.10"	0.50"
14" - 24"	OD + 4.15"	0.75"
30" - 36"	OD + 4.50"	1.00"
42" - 48"	OD + 5.00"	1.25"
54"	OD + 5.90"	1.50"

2.03 SLEEVES

- A. Unless shown otherwise, all piping passing through walls and floors shall be installed in sleeves or wall castings accurately located before concrete is poured, or placed in position during construction of masonry walls. Sleeves passing through floors shall extend from the bottom of the floor to a point 3 inches above the finished floor, unless shown otherwise.

Water stop flanges are required on all sleeves located in floors or walls which are continually wet or under hydrostatic pressure on one or both sides of the floor or wall.

- B. Sleeves shall be cast iron, black steel pipe, or fabricated steel in accordance with details shown on the Drawings. If not shown on the Drawings, the CONTRACTOR shall submit to the ENGINEER the details of sleeves he proposes to install; and no fabrication or installation thereof shall take place until the ENGINEER's approval is obtained. Steel sleeves shall be fabricated of structural steel plate in accordance with the standards and procedures of AISC and AWS. Steel sleeve surfaces shall receive a commercial sandblast cleaning and then be shop painted in accordance with Section 09900 – Painting.
- C. When shown on the Drawings or otherwise required, the annular space between the installed piping and sleeve shall be completely sealed against a maximum hydrostatic pressure of 20 psig. Seals shall be mechanically interlocked, solid rubber links, trade name "Link-Seal", as manufactured by the Thunderline Corp., Wayne, Michigan, or equal. Rubber link, seal-type, size, and installation thereof, shall be in strict accordance with the manufacturer's recommendations. For non-fire rated walls and floors, pressure plate shall be glass reinforced nylon plastic with EPDM rubber seal and 304 stainless steel bolts and nuts. For fire rated walls and floors, two independent seals shall be provided consisting of low carbon steel, zinc galvanized pressure plates, silicon rubber seals and low carbon steel, zinc galvanized bolts and nuts.
- D. Cast iron mechanical joint adapter sleeves shall be Clow # 1429, as manufactured by the Clow Corp., or equal. Mechanical joint adapter sleeves shall be provided with suitable gasket, follower ring, and bolts to effect a proper seal. In general, sleeves installed in walls, floors, or roofs against one side of which will develop a hydrostatic pressure, or through which leakage of liquid will occur, shall be so sealed. If welded waterstop flanges are employed, welds shall be 360 degree continuous on both sides of flange.

#### 2.04 SOLID SLEEVE COUPLINGS

- A. Solid sleeve couplings shall be used to connect buried service piping where shown on the Drawings. Solid sleeves shall be ductile iron, long body and shall conform to the requirements of ANSI A21.10 (AWWA C110). Unless otherwise shown or specified, solid sleeve couplings shall be Style A11760 as manufactured by American Cast Iron Pipe Co., or equal.

#### 2.05 FLEXIBLE COUPLINGS

- A. Flexible couplings shall be as manufactured by the Red Valve Company and shall consist of a molded reinforced fabric of cotton and natural rubber. Galvanized steel retaining rings shall be furnished. End connections shall match ANSI 125 pound flanges with a minimum pressure rating of 140 psi.

#### 2.06 SLEEVE TYPE COUPLINGS

- A. Sleeve type, flexible couplings shall be furnished and installed where shown on the Drawings or otherwise required to resist internal operating pressures. In addition to that specified herein, harnessed, sleeve type flexible couplings shall be provided on all exposed pipe 3 inches and larger in diameter that spans any expansion joint in a building or structure.

- B. Materials shall be of high strength steel and couplings shall be rated for the same pressures as the connecting piping.
- C. Gaskets shall be rubber. Bolts and nuts shall be alloy steel, corrosion-resistant and prime coated.
- D. Couplings shall be shop primed with a premium quality primer compatible with the painting system specified in Section 09900 - Painting. Field painting of wetted area shall be done prior to installation.
- E. Harnessing
  - 1. Harness couplings to adjacent flanges as shown, specified or otherwise required to restrain all pressure piping.
  - 2. Dimensions, sizes, spacing and materials for lugs, tie rods, washers, and nuts shall conform to the standards for the pipe size, and design pressure specified.
  - 3. No less than two (2) bolts shall be furnished for each coupling.
  - 4. Tie bolts, nuts and washers shall be ASTM A 193, Grade B7 steel or better and as a minimum shall be hot dip galvanized.
  - 5. Harness rods shall have lengths less than 10 feet between adjacent flanged joints on fittings and as a minimum shall be hot dip galvanized.
- F. Couplings shall be as manufactured by Dresser Industries, Style 38, or equal as required and shown on the Drawings. All couplings shall be provided without interior pipe stop.

## 2.07 FLANGED ADAPTERS

- A. Flanged adapters shall be furnished as required and as shown on the Drawings.
- B. All flanged adapters, 12 inches in diameter and smaller, except as shown on the Drawings or directed by the ENGINEER, shall be locking type flanged adapters.
- C. Pressure and service shall be the same as connected piping.
- D. Materials shall be cast iron for pipes up to 12 inch diameter and high strength steel for pipes larger than 12 inch diameter.
- E. Flanged adapters shall be shop primed with a premium quality primer compatible with the paint system specified in Section 09900 – Painting. Field painting of wetted area shall be done prior to installation.
- F. Bolts and nuts shall be alloy steel, corrosion-resistant and prime coated.
- G. Where identified on the Drawings, flanged coupling adapters shall be harnessed by tying the adapter to the nearest pipe joint flange using threaded rods and rod tabs. The threaded

rods, rod tabs, nuts, bolts and washers shall be as shown on the Drawings and as a minimum shall be hot dip galvanized.

- H. Flanged adapters shall be as manufactured by Dresser Industries, Style 127 or 128, Smith Blair Corporation, or equal.

#### 2.08 MECHANICAL COUPLINGS (SPLIT TYPE - SHOULDERED END)

- A. Mechanical couplings (split type-shouldered end) shall be furnished as specified or shown on the Drawings.
- B. Materials shall be of malleable iron and couplings shall be rated for the same pressures as the connecting piping.
- C. Gaskets shall be rubber. Bolts and nuts shall be heat treated carbon steel track bolts and shall be plated.
- D. After installation, buried couplings shall receive two heavy coats of an approved coal tar which is compatible with the finish of the coupling. Exposed couplings shall be painted in accordance with Section 09900 - Painting.
- E. Couplings shall be as manufactured by Victaulic Company of America, Style 44, or equal.

#### 2.09 UNIONS

- A. For ductile iron, carbon steel, and grey cast iron pipes assembled with threaded joints and malleable iron fittings, unions shall conform to ANSI B16.39.
- B. For copper piping, unions shall have ground joints and conform to ANSI B16.18.
- C. For PVC and CPVC piping, unions shall be socket weld type with Viton O-ring.

#### 2.10 THERMOPLASTIC TUBING AND FITTINGS

- A. Thermoplastic tubing shall be manufactured from polyallomor tubing. Tubing shall be protected from ultraviolet radiation degradation with a black coating or integral color conforming to ASTM D-1248, Type 1, Class C, Category 3. Fittings and connectors used with thermoplastic tubing shall be the flareless tube type constructed of brass conforming to SAE CA377, SAE CA360 or equal. Brass sleeves shall be used.
- B. Assembly of the thermoplastic tubing shall consist of pushing the tubing into the fitting and hand tightening the nut with final tightening with a wrench. Care shall be taken not to overtighten the nut. Plastic tube racks and bend holders shall be provided for holding the tubing in position. Needle valves used with thermoplastic tubing shall be the globe type constructed with a brass body, stem and seat and Buna-N "O"-ring seals. Installation shall be in accordance with the manufacturer's recommendations. Thermoplastic tubing, shall be the Impolene (polyallomor) system and needle valves, fittings and connectors shall be the Poly-Flo with 261 UB Universal Nut and Sleeve system as manufactured by Imperial Eastman, or equal.

#### 2.11 RESTRAINED JOINTS



- A. Where required for ductile iron pipe, unless specified elsewhere, all mechanical joint fittings, valves and appurtenances shall be restrained as described herein. The restraint rings shall be manufactured of ductile iron conforming to ASTM A536 and incorporate a plurality of individually-actuating gripping surfaces to grip the pipe. The restraint device shall be coated in MEGA-BOND Restraint Coating System. The restraint system shall consist of two series 1100 MEGALUGS mechanical joint restraint follower glands with the second follower gland having the mechanical joint lip removed at the factory to seat properly behind the first. The restraint system shall have a sufficient number of fastening bolts to connect the rings to the mechanical joint. Torque limiting twist off nuts shall be used to ensure proper actuation of the restraining wedges. The restraint system shall have a minimum safety factor of 2 to 1. The restraint system shall be the Series 1100TDM Tandem MEGALUG Mechanical Joint Restraint manufactured by EBAA Iron, Inc., no exceptions.
- B. Where required for PVC pipe, unless specified elsewhere, restrained joint retainer glands shall be used and shall be cast from 60-42-10 ductile iron and shall have a sufficient number of ductile tie bolts to restrain working test pressure as required. The retainer clamp shall be of two piece construction with serrations on the I.D. sufficient to hold the required pressures with a safety factor of 2:1. The retainers shall be Series 1500 or 6500 as manufactured by EBAA Iron, Inc., no exceptions.

### PART 3 -- EXECUTION

#### 3.01 INSTALLATION

- A. All piping shall be installed by skilled workmen and in accordance with the best standard practice for piping installation as shown on the Drawings, specified or recommended by the pipe manufacturer. Proper tools and appliances for the safe and convenient handling and installing of the pipe and fittings shall be used. Great care shall be taken to prevent any pipe coating from being damaged on the inside or outside of the pipe and fittings. All pieces shall be carefully examined for defects, and no piece shall be installed which is known to be cracked, damaged, or otherwise defective. If any defective pieces should be discovered after having been installed, it shall be removed and replaced with a sound one in a satisfactory manner by the CONTRACTOR and at his own expense. Pipe and fittings shall be thoroughly cleaned before they are installed and shall be kept clean until they are accepted in the complete work. All piping connections to equipment shall be provided with unions or coupling flanges located so that piping may be readily dismantled from the equipment. At certain applications, Dresser, Victaulic, or equal, couplings may also be used. All piping shall be installed in such a manner that it will be free to expand and contract without injury to itself or to structures and equipment to which it is connected. All piping shall be erected to accurate lines and grades with no abrupt changes in line or grade and shall be supported and braced against movement, temporary, or permanent. All exposed piping shall be installed with vertical and horizontal angles properly related to adjoining surfaces or pipes to give the appearance of good workmanship. Unless otherwise shown or approved, provided a minimum headroom clearance under all piping of 7 feet 6 inches.
- B. Unless otherwise shown or specified, all waste and vent piping shall pitch uniformly at a 1/4-inch per foot grade and accessible cleanouts shall be furnished and installed as shown

and as required by local building codes. Installed length of waste and vent piping shall be determined from field measurements in lieu of the Drawings.

- C. All excavation shall be made in such a manner and to such widths as will provide ample room for properly installing the pipe and permit thorough compaction of backfill around the pipe. The minimum trench widths shall be in strict accordance with the "Trench Width Excavation Limits" as shown on the Drawings. All excavation and trenching shall be done in strict accordance with these specifications and all applicable parts of the OSHA Regulations, 29CFR 1926, Subpart P.
- D. ALL EXCAVATION REQUIRED BY THIS CONTRACT SHALL BE UNCLASSIFIED. NO ADDITIONAL PAYMENT WILL BE MADE FOR ROCK EXCAVATION REQUIRED FOR THE INSTALLATION OF PIPE OR STRUCTURES SHOWN ON THE DRAWINGS.
- E. Enlargements of the trench shall be made as needed to give ample space for operations at pipe joints. The width of the trench shall be limited to the maximum dimensions shown on the Drawings, except where a wider trench is needed for the installation of and work within sheeting and bracing. Except where otherwise specified, excavation slopes shall be flat enough to avoid slides which will cause disturbance of the subgrade, damage to adjacent areas, or endanger the lives or safety of persons in the vicinity.
- F. Hand excavation shall be employed wherever, in the opinion of the ENGINEER, it is necessary for the protection of existing utilities, poles, trees, pavements, or obstructions.
- G. No greater length of trench in any location shall be left open, in advance of pipe laying, than shall be authorized or directed by the ENGINEER and, in general, such length shall be limited to approximately one hundred (100) feet. The CONTRACTOR shall excavate the trenches to the full depth, width and grade indicated on the Drawings including the relevant requirements for bedding. The trench bottoms shall then be examined by the ENGINEER as to the condition and bearing value before any pipe is laid or bedding is placed.
- H. No pressure testing shall be performed until the pipe has been properly backfilled in place. All pipe passing through walls and/or floors shall be provided with wall pipes or sleeves in accordance with the specifications and the details shown on the Drawings. All wall pipes shall be of ductile iron and shall have a water stop located in the center of the wall. Each wall pipe shall be of the same class, thickness, and interior coating as the piping to which it is joined. All buried wall pipes shall have a coal tar outside coating on exposed surfaces.
- I. JOINT DEFLECTION SHALL NOT EXCEED 75 PERCENT OF THE MANUFACTURERS RECOMMENDED DEFLECTION. Excavation and backfilling shall conform to the requirements of Division 2, and as specified herein. Maximum trench widths shall conform to the Trench Width Excavation Limits shown on the Drawings. All exposed, submerged, and buried piping shall be adequately supported and braced by means of hangers, concrete piers, pipe supports, or otherwise as may be required by the location.
- J. Following proper preparation of the trench subgrade, pipe and fittings shall be carefully lowered into the trench so as to prevent dirt and other foreign substances from gaining entrance into the pipe and fittings. Proper facilities shall be provided for lowering sections of pipe into trenches. UNDER NO CIRCUMSTANCES SHALL ANY OF THE MATERIALS BE DROPPED OR DUMPED INTO THE TRENCH.

- K. Water shall be kept out of the trench until jointing and backfilling are completed. When work is not in progress, open ends of pipe, fittings, and valves shall be securely closed so that no water, earth, or other substance will enter the pipes, fitting, or valves. Pipe ends left for future connections shall be valved, plugged, or capped, and anchored as required.
  - L. All piping shall be installed in such a manner that it will be free to expand and/or contract without injury to itself or to structures and equipment to which it is connected. All piping shall be erected to accurate lines and grades with no abrupt changes in line or grade and shall be supported and braced against movement, temporary, or permanent. All exposed piping shall be installed with vertical and horizontal angles properly related to adjoining surfaces or pipes to give the appearance of good workmanship. Pipes crossing within a vertical distance of less than or equal to one (1) foot shall be encased and supported with concrete at the point of crossing to prevent damage to the adjacent pipes as shown on the Drawings.
  - M. The full length of each section of pipe shall rest solidly upon the bed of the trench, with recesses excavated to accommodate bells, couplings, joints, and fittings. Before joints are made, each pipe shall be well bedded on a solid foundation; and no pipe shall be brought into position until the preceding length has been thoroughly bedded and secured in place. Pipe that has the grade or joint disturbed after laying shall be taken up and relaid by the CONTRACTOR at his own expense. Pipe shall not be laid in water or when trench conditions are unsuitable for work.
  - N. Proper and suitable tools and appliances for the safe convenient handling and laying of pipe shall be used and shall in general agree with manufacturer's recommendations.
  - O. AT THE CLOSE OF EACH WORK DAY THE END OF THE PIPELINE SHALL BE TIGHTLY SEALED WITH A CAP OR PLUG SO THAT NO WATER, DIRT, OR OTHER FOREIGN SUBSTANCE MAY ENTER THE PIPELINE, AND THIS PLUG SHALL BE KEPT IN PLACE UNTIL PIPE LAYING IS RESUMED.
  - P. During the laying of pipe, each pipe manufacturer shall provide his own supervisor to instruct the CONTRACTOR's pipe laying personnel in the correct procedure to be followed.
  - Q. Ordinarily only full lengths of pipe (as furnished by the pipe manufacturer) shall be used exceptions: closure pieces at manholes and areas where joint deflection is required.
  - R. For gravity sewer installations, the CONTRACTOR shall use a laser device to maintain the trench and pipe alignment. The laser device shall be re-checked for correct elevation and pipe alignment prior to pipe installation if the device is left in the pipe overnight. Corrected invert elevations at each manhole and any adjustments will be coordinated and approved by the ENGINEER.
  - S. ALL PIPING SHALL HAVE TYPE "A" BEDDING AS SHOWN ON THE DRAWINGS, UNLESS OTHERWISE SPECIFIED HEREIN OR INDICATED ON THE DRAWINGS.
- 3.02 REINFORCED CONCRETE PIPE, CONCRETE CULVERT, AND DRAIN PIPE
- A. The laying of reinforced concrete pipe shall conform to the applicable sections of the Concrete Pipe Handbook as published by the American Concrete Pipe Association.

### 3.03 DUCTILE IRON PIPE

- A. Ductile iron pipe (DIP) shall be installed in accordance with the requirements of the Ductile Iron Pipe Handbook published by the Ductile Iron Pipe Research Association, and AWWA C600.
- B. Where it is necessary to cut ductile iron pipe in the field, such cuts shall be made carefully in a neat workmanlike manner using approved methods to produce a clean square cut. The outside of the cut end shall be conditioned for use by filing or grinding a small taper, at an angle of approximately 30 degrees.
- C. UNLESS OTHERWISE APPROVED BY THE ENGINEER, FIELD WELDING OF DUCTILE IRON WILL NOT BE PERMITTED.

### 3.04 PVC/CPVC AND HDPE PIPE

- A. Polyvinyl chloride (PVC), chlorinated polyvinyl chloride (CPVC) and High Density Polyethylene (HDPE) pipe shall be laid and joints assembled according to the respective manufacturer's recommendation. PVC pipe installation shall comply with applicable sections of the Uni-Bell PVC Pipe Association Recommended Standard Specifications.
- B. Plastic piping shall not be installed when the temperature is less than 60 degrees F except as otherwise recommended by the manufacturer and approved by the ENGINEER.

### 3.05 CARBON AND STAINLESS STEEL PIPE

- A. Installation of steel pipe shall be by skilled workmen and shall conform to the applicable sections of AWWA Manual M-11. Joints for steel piping shall be either screwed, welded, or flanged as shown on the Drawings or as specified.
- B. Welding in the field shall be performed only when requested on the shop drawings and permitted by the ENGINEER for carbon steel pipe. No welding of stainless steel pipe shall be allowed in the field. All field welds shall be radiographically inspected.
- C. Installation of the steel casing pipe shall be by skilled workmen and in accordance with the best standard practice for steel pipe installation. Joints for steel casing pipe shall be butt welded.
  - 1. The boring equipment to be used for installing the jacked casing shall be of such size and capacity to allow the boring to proceed in a safe and expeditious manner. The installation of the casing and boring of the hole shall be done simultaneously to avoid cave-ins or settlement and for safety of traffic above.
  - 2. The CONTRACTOR shall check the vertical and horizontal alignment of the casing by survey instrument at least once during each four feet of advance, or as directed by the ENGINEER. Pits shall be well sheeted and braced as necessary for safe and adequate access for workmen, inspectors and materials and shall be of a size suitable to equipment and material handling requirements.
  - 3. Under no conditions shall jetting or wet boring of encasement under pavement be allowed.

4. After installation of the carrier pipe, each end of the casing pipe shall be made watertight with a brick masonry bulkhead. In addition, a Class B concrete cradle shall be provided from each end of the bulkhead to the first pipe joint outside of the bulkhead.

### 3.06 COPPER PIPE

- A. Installation of copper pipe shall be by skilled workman in accordance with the manufacturer's recommendations. Use teflon tape at all fittings unless otherwise required for intended service. Install unions at the connections to each piece of equipment to allow removal of equipment without dismantling connecting piping.
- B. Wall sleeves shall be provided for all piping passing through exterior walls and shall be of the same material as the piping to which it is joined. All wall sleeves shall be provided with an acceptable waterstop.
- C. The CONTRACTOR shall provide hot and cold water mains with branches and risers complete from point indicated on the Drawings running to all fixtures and other outlets indicated. Mains and branches shall be run generally as shown on the Drawings. The CONTRACTOR shall provide all interior water piping, branches, and risers as shown on the Drawing and shall make connections to all plumbing fixtures, hose bibs, wall hydrants, and other points requiring water under this and other Divisions of the Specifications.
- D. All water mains and branches shall be pitched at least one (1) inch in twenty-five (25) feet toward fixtures. The piping installation shall be arranged so that the entire system can be drained through fixture supply connections.
- E. Unions shall be installed at the connections to each piece of equipment to allow for removal of equipment without dismantling connecting piping.
- F. Joints 1-1/4 inches and larger shall be made with silver solder. For joints less than 1-1/4 inches and all valves (regardless of size) use 95/5 solder. Soldered joints shall be prepared with a non-corrosive paste flux in accordance with manufacturer's instructions. All joints shall be thoroughly cleaned with emery cloth and reamed out before assembly. Acid core solder will not be permitted.

### 3.07 JOINTS IN PIPING

- A. Restrained joints shall be provided on all pipe joints as specified herein and shown on the Drawings. Restrained joints shall be made up similar to that for push-on joints.
- B. Push-on joints include a single rubber gasket which fits into the bell end of the pipe. The gasket shall be wiped clean, flexed and then placed in the socket. Any bulges in the gasket which might interfere with the entry of the plain end of the pipe shall be removed. A thin film of lubricant shall be applied to the gasket surface which will come into contact with the spigot end of the pipe. The lubricant shall be furnished by the pipe manufacturer. The plain end of the pipe, which is tapered for ease of assembly, shall be wiped clean and a thick film of lubricant applied to the outside. The pipe shall be aligned and carefully entered into the socket until it just makes contact with the gasket. The joint assembly shall be completed by entering the pipe past the gasket until it makes contact with the bottom of the socket. The

pipe shall be pulled "home" with an approved jack assembly as recommended by the pipe manufacturer. If assembly is not accomplished by reasonable force, the plain end shall be removed and the condition corrected.

- C. Flanged joints shall be brought to exact alignment and all gaskets and bolts or studs inserted in their proper places. Bolts or studs shall be uniformly tightened around the joints. Where stud bolts are used, the bolts shall be uniformly centered in the connections and equal pressure applied to each nut on the stud. Pipes in all lines subject to temperature changes shall be cut short and cold sprung into place to compensate for expansion when hot.
- D. Mechanical joints shall be made up with gaskets, glands and bolts. When a joint is to be made up, the bell or socket and plain end shall be cleaned and washed with a solution of mild soap in water; the gland and gasket shall be slid onto the plain end and the end then entered into the socket until it is fully "home" on the centering ring. The gasket shall then be painted with soapy water and slid into position, followed by the gland. All bolts shall be inserted and made up hand tight and then tightened alternately to bring the gland into position evenly. Excessive tightening of the bolts shall be avoided. All nuts shall be pulled up using a torque wrench which will not permit unequal stresses in the bolts. Torque shall not exceed the recommendations of the manufacturer of the pipe and bolts for the various sizes. Care shall be taken to assure that the pipe remains fully "home" while the joint is being made. Joints shall conform to the applicable AWWA Specifications.
- E. Threaded and/or screwed joints shall have long tapered full depth threads to be made with the appropriate paste or jointing compound, depending on the type of fluid to be processed through the pipe. All pipe up to, and including 1-1/2-inches, shall be reamed to remove burr and stood on end and well pounded to remove scale and dirt. Wrenches on valves and fittings shall be applied directly over the joint being tightened. Not more than three pipe threads shall be exposed at each connection. Pipe, in all lines subject to temperature changes shall be cut short and cold sprung into place to compensate for expansion when hot. Joints in all piping used for chlorine gas lines shall be made up with a glycerine and litharge cement. Joints in plastic piping (PVC/CPVC) shall be laid and joints made with compounds recommended by the manufacturer. Installation shall conform to the requirements of ASTM D2774 and ASTM D2855. Unions required adjacent to valves and equipment.
- F. Soldered joints shall have the burrs removed and both the outside of pipe and the inside of fittings shall be thoroughly cleaned by proper tools recommended for that purpose. Flux shall be applied to both pipe and inside of fittings and the pipe placed into fittings and rotated to insure equal distribution of flux. Joints shall be heated and solder applied until it shows uniformly around the end of joints between fitting and pipe. All joints shall be allowed to self-cool to prevent the chilling of solder. Combination flux and solder paste manufactured by a reputable manufacturer is acceptable. Unions required adjacent to valves and equipment.
- G. Welded joints shall be made by competent operators in a first class workmanlike manner, in complete accordance with ANSI B31.1 and AWWA C206. Welding electrodes shall conform to ASTM A233, and welding rod shall conform to ASTM A251. Only skilled welders capable of meeting the qualification tests for the type of welding which they are performing shall be employed. Tests, if so required, shall be made at the expense of the CONTRACTOR, if so ordered by the ENGINEER. Unions shall be required adjacent to valves and equipment.

- H. Copper joints shall be thoroughly cleaned and the end of pipes uniformly flared by a suitable tool to the bevels of the fittings used. Wrenches shall be applied to the bodies of fittings where the joint is being made and in no case to a joint previously made. Dimensions of tubing and copper piping shall be in complete accordance with the fittings used. No flare joints shall be made on piping not suited for flare joints. Installations for propane gas shall be in accordance with NFPA 54 and/or 58.
- I. Solvent or adhesive welded joints in plastic piping shall be accomplished in strict accordance with the pipe manufacturer's recommendations, including necessary field cuttings, sanding of pipe ends, joint support during setting period, etc. Care shall be taken that no droppings or deposits of adhesive or material remain inside the assembled piping. Solvent or adhesive material shall be compatible with the pipe itself, being a product approved by the pipe manufacturer. Unions are required adjacent to valves and equipment. Sleeve-type expansion joints shall be supplied in exposed piping to permit 1-inch minimum of expansion per 100 feet of pipe length.
- J. Dielectric unions shall be installed wherever dissimilar metals are connected except for bronze or brass valves in ferrous piping. Unions shall be provided downstream of each valve with screwed connections. The CONTRACTOR shall provide screwed or flanged unions at each piece of equipment, where shown, and where necessary to install or dismantle piping.
- K. Eccentric reducers shall be installed where air or water pockets would otherwise occur in mains because of a reduction in pipe size.
- L. Joints in polypropylene and polyvinylidene fluoride pipe shall be butt fusion weld. All butt welding shall follow the requirements of ASTM D-2657 and the manufacturer's recommendations.

### 3.08 PAINTING AND COLOR CODING SYSTEM

- A. All exposed piping specified shall be color coded in accordance with the CITY's standard color designation system for pipe recognition and in accordance with Section 15030 – Piping and Equipment Identification Systems. In the absence of a standard color designation system, the ENGINEER will establish a standard color designation for each piping service category from color charts submitted by the CONTRACTOR in compliance with Section 09900 – Painting.
- B. All piping specified in this Section shall be painted in accordance with Section 09900 – Painting, except as follows:
  - 1. Copper pipe
  - 2. Stainless steel pipe. Flanges and supports or hangers shall be painted.

- END OF SECTION -

## SECTION 15006 - DUCTILE IRON PIPE

### PART 1 -- GENERAL

#### 1.01 WORK INCLUDED

- A. The Contractor shall furnish and install ductile iron pipe and all appurtenant Work, complete in place, all in accordance with the requirements of the Contract Documents.

#### 1.02 RELATED WORK SPECIFIED ELSEWHERE

- A. Materials and Equipment
- B. Excavation and Backfill for Utilities
- C. Submittals
- D. Painting
- E. Basic Mechanical Requirements
- F. Schedules
- G. Pipeline Testing

#### 1.03 REFERENCED SPECIFICATIONS, CODES, AND STANDARDS

##### A. Commercial Standards:

ANSI/AWWA C104/A21.4	Cement Mortar Lining for Ductile Iron Pipe and Fittings for Water
ANSI/AWWA C110/A21.10	Ductile-iron and Gray-Iron Fittings 3-in. Through 60-in. for Water and Other Liquids
ANSI/AWWA C111/A21.11	Rubber-Gasket Joints for Ductile-Iron and Gray-Iron Pressure Pipe and Fittings
ANSI/AWWA C150/A21.50	Thickness design of ductile iron pipe
ANSI/AWWA C151/A21.51	Ductile-iron Pipe, Centrifugally Cast in Metal Molds or Sand-Lined Molds, for Water or Other Liquids
ANSI/AWWA C600	Installation of Ductile-Iron Water Mains and Appurtenances

#### 1.04 SUBMITTALS

- A. Shop Drawings: The Contractor shall submit Shop Drawings of pipe and fittings in accordance with the requirements set forth in the Sections entitled "Basic Mechanical Requirements" and "Submittals".



- B. Contractor shall submit certification that all materials coming in contact with potable water comply with the requirements of NSF 61.

#### 1.05 SCHEDULE OF PIPING MATERIALS

- A. A schedule of piping materials is included in the Section entitled "Schedules". The schedule indicates service, nominal pipe size, material, wall thickness, joint type, working pressure, test pressure, joints, coatings and linings.

### PART 2 -- PRODUCTS

#### 2.01 GENERAL

- A. The City of Hollywood requires all ductile iron pipe and fittings to be manufactured in America.
- B. Pipe shall be centrifugally cast in metal molds or sand lined molds in accordance with ANSI A21.51 (AWWA C151) of grade 60-42-10 ductile iron. The above standard covers ductile iron pipe with nominal pipe sizes from three inches up to and including sixty-four inches in diameter. Working pressure shall be as specified herein, unless higher pressure is indicated on the Piping Schedule in Section 15390 – Schedules.
- B. Wall Thickness
  - 1. Buried Pipe: Pressure Class 350
  - 2. Flanged Pipe: Pipe wall thickness of threaded pipe for a flanged pipe end shall be minimum special thickness Class 53 from 4-inch to 54-inch and/or minimum pressure Class 350 for 60-inch to 64-inch diameter pipe in accordance with AWWA C115.
  - 3. Grooved Pipe: Grooved coupling pipe shall be Special Thickness Class 54.
- C. Joints
  - 1. Ductile iron pipe above grade shall be flanged.
  - 2. All pipe and fittings below grade shall be restrained joint type.
  - 3. Mechanical and push-on type joints shall be in accordance with ANSI A21.11 (AWWA C111).
  - 4. Flanges for flanged pipe shall be in accordance with ANSI A21.15 (AWWA C115), shall be ductile iron, shall be rated at 250 psi maximum working pressure, and shall be similar to flange Class 125 per ANSI B16.1. Where shown on the Drawings, pipe and fittings shall be furnished with flanges similar to flange Class 250 per ANSI B16.1. Fittings shall be provided with flanges having a bolt circle and bolt pattern the same as the adjacent pipe and/or mechanical devices.
  - 5. Bolts: hot dip galvanized carbon steel bolts and nuts.

6. No raised face flanges shall be used. The raised faces shall be milled flat.
7. Gasket Material: Gaskets shall be full faced neoprene rubber for wastewater service.

D. Restrained Joints

1. All ductile iron pipe and fittings below grade shall be restrained joint.
2. Manufactured Proprietary Restrained Joint Piping and Fittings: Restrained joint pipe and fittings shall be Flex-Ring or Lok-Ring type as manufactured by American Cast Iron Pipe, TR Flex as manufactured by U.S. Pipe, or equal.
3. Restrained Mechanical Joint Fittings: All mechanical joint fittings, valves and appurtenances shall be restrained as described herein. The restraint rings shall be manufactured of ductile iron conforming to ASTM A536 and incorporate a plurality of individually-actuating gripping surfaces to grip the pipe. The restraint device shall be coated in MEGA-BOND Restraint Coating System. The restraint system shall consist of two series 1100 MEGALUGS mechanical joint restraint follower glands with the second follower gland having the mechanical joint lip removed at the factory to seat properly behind the first. The restraint system shall have a sufficient number of fastening bolts to connect the rings to the mechanical joint. Torque limiting twist off nuts shall be used to ensure proper actuation of the restraining wedges. The restraint system shall have a minimum safety factor of 2 to 1. The restraint system shall be the Series 1100TDM Tandem MEGALUG Mechanical Joint Restraint manufactured by EBAA Iron, Inc., no exceptions.
4. Restraining System for Field Cut Piping: Use only in areas where adjoining to fixed points where laying length is determined in field and requires field cutting of the pipe. Ductile iron pipe bell restraint shall consist of a wedge action restraint ring on the spigot joined to a split ductile iron ring behind the bell. The restraint ring shall have individually actuated wedges that increase their resistance to pull-out as pressure or external forces increase. Torque limiting twist off nuts shall be used to ensure proper actuation of the restraining wedges. The restraint devices shall be coated using MEGA-BOND. The product shall be the Series 1700 Megalug restraint harness, manufactured by EBAA Iron, Inc., no exceptions.

E. Fittings

1. General: Fittings shall be manufactured in accordance with AWWA C110 or AWWA C153 or the manufacturer's standard.
2. Materials: Fittings shall be ductile iron.
3. Joints - General: Fittings shall be either flanged, mechanical joint or manufactured proprietary restrained joint type as indicated on the Drawings and specified herein.
4. Flanged Joint Fittings: Above ground fittings shall be flanged.
5. Manufacturer Proprietary Restrained Joint Fittings: All below ground fittings 30-inches in diameter and greater shall be manufacturer proprietary restrained joint

type.

6. Mechanical Joint Fittings: Underground ductile iron fittings 24-inches in diameter and less shall be mechanical joint type fittings.

F. Joint Pressure Ratings:

1. Flanged Joints: The flanges shall be rated for at least 250 psi working pressure.
2. Grooved Joints:
  - a) Fittings 4 to 36-inch Diameter with Grooved Joints: Maximum 250 psi working pressure.
  - b) Grooved Couplings 4 to 18-inch Diameter: Maximum 250 psi working pressure
  - c) Grooved Couplings 20 to 36-inch Diameter: Maximum 150 psi working pressure.
3. Restrained, Push-on and Mechanical Joints:
  - a) 4 to 24-inch Diameter: Maximum 350 psi working pressure.
  - b) 30 to 64-inch Diameter: Maximum 250 psi working pressure.

F. Pipe Lining and Coating General: Pipe linings and coatings shall be as follows.

1. Buried Service: The piping manufacturer's standard asphaltic coating shall be applied prior to shipment to the exterior wall of buried pipe and fittings in accordance with AWWA C151.
2. Above Ground Piping and Exposed Piping within Underground Vaults: A coating of rust inhibitive primer, compatible with the coating system specified in Section 09900 – Painting, shall be applied to the pipe exterior prior to shipment for piping that is above ground and exposed piping within vaults. Primer for pipe used for potable water main applications shall be compliant with NSF Standard 61.
3. Cement-Mortar Lining: Where scheduled, pipe and fittings shall be cement-lined and seal-coated in accordance with AWWA C104, Cement-Mortar Lining for Ductile-Iron Pipe and Fittings for Water.
4. Protecto 401 Ceramic Epoxy Lining: The interior of all ductile iron pipe and fittings for non-potable service shall be lined with an epoxy lining, unless otherwise specified. The epoxy lining shall be Protecto 401 Ceramic Epoxy as manufactured by the Protecto Division of Vulcan Painters, Inc, or equal. All pipe and fittings shall be lined with a minimum dry film thickness of 40 mils, except for the gasket groove and spigot end up to six inches back from the end of the spigot which shall be lined with ten mils of the material. All ductile iron pipe and fittings shall be checked for dry film thickness in accordance with the SSPC-PA2. Each pipe joint and fitting shall be marked with the date of application of the lining system and with its numerical sequence of application on that date. The pipe supplier shall furnish a certificate stating that lining applicator has complied with all specification requirements relative

to the material, its application and inspection. Surface preparation, number of coats, application of the lining material and field touch-up shall be in strict accordance with the lining material manufacturer's recommendations. During the installation of the pipe, the lining material manufacturer shall provide the services of a field engineer to instruct and demonstrate to the CONTRACTOR's personnel, the procedure for the field touch-up of lining where field cuts and taps were required. Holiday inspection shall be conducted using test equipment described in American Water Works Association Standard, AWWA C210, Section 5.3.3.1. In accordance with coating manufacturer's recommendation, holiday testing may be conducted any time after the coating has reached sufficient cure.

5. Polyethylene Encasement: All ductile iron pipe, fittings and valves installed underground shall be encased with polyethylene film in accordance with ANSI Standard A21.5, Method A or B at the CONTRACTOR's option. Encasement shall terminate 3-inches to 6-inches above ground where pipe is exposed

F. Color Coding for Potable Water Mains:

1. Above Ground Piping: Pipe used for potable water main applications in above ground service shall be painted blue.
2. Below Ground Piping: Pipe used for potable water main applications in below ground service shall have a continuous blue line painted along the top of the pipe.

## PART 3 -- EXECUTION

### 3.01 INSTALLATION

- A. The Contractor shall perform all earthwork including excavation, backfill, bedding, compaction, sheeting, shoring and bracing, dewatering and grading in accordance with Division 2 - Sitework.
- B. Unless otherwise directed, ductile iron pipe shall be laid with the bell ends facing upstream in the normal direction of flow and in the direction of laying.
- C. Thrust restrained and mechanical joints shall be made in accordance with the manufacturer's standards except as otherwise specified herein. Joints between mechanical joint pipe and/or fittings shall be made in accordance with ANSI/AWWA Standard C600, except that deflection at joints shall not exceed one-half of the manufacturer's recommended allowable deflection, or one-half of the allowable deflection specified in ANSI/AWWA C600, whichever is the lesser amount.
- D. Before laying thrust restrained and mechanical joint pipe and fittings, all lumps, blisters and excess bituminous coating shall be removed from the bell and spigot ends. The outside of each spigot and the inside of each bell shall be wire brushed, and wiped clean and dry. The entire gasket groove area shall be free of bumps or any foreign matter which might displace the gasket. The cleaned spigot and gasket shall not be allowed to touch the trench walls or trench bottom at any time. Vegetable soap lubricant shall be applied in accordance with the pipe manufacturer's recommendations, to aid in making the joint. The workmen shall exercise caution to prevent damage to the gasket or the adherence of grease or particles of sand or dirt. Deflections shall only be made after the joint has been assembled.

- E. Prior to making up flanged joints in ductile iron pipe and fittings, the back of each flange under the bolt heads and the face of each flange shall have all lumps, blisters and excess bituminous coating removed and shall be wire brushed and wiped clean and dry. Flange faces shall be kept clean and dry when making up the joint, and the workmen shall exercise caution to prevent damage to the gasket or the adherence of grease or particles of sand or dirt. Bolts and nuts shall be tightened by opposites in order to keep flange faces square with each other, and to insure that bolt stresses are evenly distributed.
- F. Bolts and nuts in thrust restrained, mechanical and flanged joints shall be tightened in accordance with the recommendations of the pipe manufacturer for a leak-free joint. The mechanics shall exercise caution to prevent overstress. Torque wrenches shall be used until, in the opinion of the ENGINEER, the mechanics have become accustomed to the proper amount of pressure to apply on standard wrenches.
- G. Cutting of the ductile iron pipe for inserting valves, fittings, etc., shall be done by the Contractor in a neat and workmanlike manner without damage to the pipe, the lining, or the coating. Pipe 16 inches and larger in diameter shall be cut with a mechanical pipe saw. After cutting the pipe, the plain end shall be beveled with a heavy file or grinder to remove all sharp edges.
- H. Areas of loose or damaged lining associated with field cutting shall be repaired or replaced as recommended by the pipe manufacturer and required by the ENGINEER. Repair methods shall be as recommended by the manufacturer and shall be submitted to the ENGINEER for review.
- I. Any work within the pipe shall be performed with care to prevent damage to the lining. No cable, lifting arms or other devices shall be inserted into the pipe. All lifting, pulling or pushing mechanisms shall be applied to the exterior of the pipe barrel.
- J. Homing the pipe shall be accomplished by the use of a hydraulic or mechanical pulling device, unless otherwise accepted by the ENGINEER. No pipe shall be driven or struck in order to seat it home.
- K. Cleaning: Cleaning methods shall be acceptable to the ENGINEER, and must be sufficient to remove silt, rocks, or other debris which may have entered the pipeline during its installation and shall also follow the requirements of Section 15995, "Pipeline Testing and Disinfection".

- END OF SECTION -

## SECTION 15009 – PVC PRESSURE PIPE

### PART 1 – GENERAL

#### 1.01 THE REQUIREMENT

- A. This section includes materials, installation, and testing of polyvinyl chloride (PVC) pipe and fittings for use in process piping having a maximum operating pressure of 150 psi at a maximum operating temperature of 100 degrees F and a maximum operating pressure of 100 psi at a temperature of 120 degrees F.

#### 1.02 RELATED WORK SPECIFIED ELSEWHERE

- A. Section 01300 – Submittals
- B. Section 01600 – Materials and Equipment
- C. Section 15000 – Basic Mechanical Requirements

#### 1.03 SUBMITTALS

- A. Submit shop drawings in accordance with the General Conditions.
- B. Submit materials list.
- C. Submit manufacturer's recommended method of installing buried pipe. Show alignments and offsets for "snaking" buried pipe.

### PART 2 -- MATERIALS

#### 2.01 PIPE

- A. Pipe shall be Schedule 80, Type 1, Grade 1 (Class 12454B), conforming to ASTM D 1784, except as noted below.

#### 2.02 NIPPLES

- A. Short nipples shall be the same as the PVC pipe.

#### 2.03 FITTINGS

- A. Fittings shall be Schedule 80 and shall conform to ASTM D 2464 for threaded fittings and ASTM D 2467 for socket-type fittings.

#### 2.04 FLANGES

- A. PVC flanges shall be made of the same material as the pipe. Flanges shall match the dimensions of ANSI B16.5, Class 150, steel flanges. Flanges shall be flat face.
- B. Flanges shall be Van Stone style unless otherwise noted.

## 2.05 UNIONS

- A. Union shall have socket-type ends, EPDM o-rings, and shall be Schedule 80. Material shall be Type 1, Grade 1 PVC, per ASTM D 1784, Class 12454B.

## 2.06 JOINTS

- A. Pipe and fittings joints shall be socket welded except where threaded and flanged joints are required to connect to unions, valves, and equipment.
- B. Solvent cement for socket joints shall comply with ASTM D 2564 and be NSF listed for potable water.
- C. Manufacturer shall provide written conformance of solvent cement with intended chemical application.

## 2.07 BOLTING AND NUTS FOR FLANGES

- A. Bolts and nuts for interior flanges shall be carbon steel conforming to ASTM A 307, Grade B.
- B. Bolts and nuts for buried flanges and flanges located outdoors above ground or in vaults and structures shall be Type 316 stainless steel conforming to ASTM A 193, Grade B8M for bolts, and ASTM A 194, Grade 8M for nuts. Bolts and nuts larger than 1-1/8 inch shall be steel, ASTM A 307, Grade B, with cadmium plating, ASTM A 165, Type NS.
- C. Provide washers for each nut. Washers shall be of the same material as the nut.

## PART 3 -- EXECUTION

### 3.01 GENERAL

- A. Do not install PVC pipe when the temperature is below 40 F or above 90 F. Store loose pipes on racks with a minimum support spacing of 3 feet. Provide shade for pipe stored outdoors or installed outdoors until the pipe is filled with water.
- B. Store fittings indoors in their original cartons.
- C. Store solvent cement indoors or, if outdoors, shade from direct sunlight exposure. Do not use solvent cements which have exceeded the shelf life marked on the storage container.
- D. Before installation, check pipe and fittings for cuts, scratches, gouges, buckling, kinking, or splitting on pipe ends. Remove any pipe section containing defects by cutting out the damaged section as a complete cylinder.

### 3.02 INSTALLATION

- A. Do not drag PVC pipe over the ground, drop it onto the ground, or drop objects on it. Cut pipe ends square and remove all burrs, chips, and fillings before joining pipe or fittings. Bevel solvent welded pipe ends as recommended by the pipe manufacturer.

### 3.03 SOLVENT WELDED JOINTS

- A. Prior to solvent welding, remove fittings and couplings from their cartons and expose them to the air for at least one hour to the same temperature conditions as the pipe.
- B. Wipe away loose dirt and moisture from the ID and OD of the pipe end and the ID of the fitting before applying solvent cement. Do not apply solvent cement to wet surfaces.
- C. Make up solvent welded joints per ASTM D 2855.
- D. Allow at least eight hours of drying time before moving solvent welded joints or subjecting the joints to any internal or external loads or pressures.

### 3.04 FLANGED JOINTS

- A. Lubricate bolt threads with MRO solution 1000 Food Grade Antiseize, or equal before installation.
- B. Tighten bolts on PVC flanges by tightening the nuts diametrically opposite each other using a torque wrench. Complete tightening shall be accomplished in stages and the final torque values shall be as shown in the following table:

<u>Pipe Size (inches)</u>	<u>Final Torque (foot-pounds)</u>
1/2 to 1-1/2	10 to 15
2 to 4	20 to 30
5 to 8	30 to 40
10	60 to 70

### 3.05 THREADED JOINTS

- A. Cut threaded ends on PVC to the dimensions of ANSI B2.1. Ends shall be square cut. Follow the pipe manufacturer's recommendations regarding pipe holddown methods, saw cutting blade size, and saw cutting speed.
- B. Pipe or tubing cutters shall be specifically designed for use on PVC pipe. Use cutters manufactured by Reed Manufacturing Company, Ridge Tool Company, or equal.
- C. If a holddown vise is used when the pipe is cut, insert a rubber sheet between the vise jaws and the pipe to protect from scratching the pipe.
- D. Thread cutting dies shall be clean and sharp and shall not be used to cut materials other than plastic.
- E. Apply Teflon thread compound or Teflon tape lubricant to threads before screwing on the fitting. Teflon tape shall be of type A-A-58092 or MIL-T-27730A manufactured by



Threadmaster or equal. Use White tape for all chemical applications and Pink tape for all water applications.

### 3.06 INSTALLING UNIONS

- A. Provide unions on exposed piping 3 inches and smaller as follows:
  - 1. Provide a union at every change in direction (horizontal and vertical).
  - 2. Provide a union 6 to 12 inches downstream of valves.
  - 3. Provide a union every 40 feet in straight piping runs.
  - 4. Near threaded connections to mechanical or piping equipment.
  - 5. Where shown on the Drawings.

### 3.07 INSTALLING BURIED PIPE

- A. Trench bottom shall be continuous, smooth, and free of rocks. See the details on the Drawings for trench dimensions, pipe bedding, and backfill.
- B. After the pipe has been solvent welded and the joints have set, snake the pipe in the trench per the pipe manufacturer's recommendations in order to allow for thermal expansion and contraction of the pipe.
- C. Do not backfill the pipe trench until the solvent welded joints have set. Support the pipe uniformly and continuously over its entire length on firm, stable soil. Do not use blocking to change pipe grade or to support pipe in the trench.
- D. Install buried PVC pipe in accordance with ASTM D 2774 and the pipe manufacturer's recommendations. Backfill materials in the zone between the trench bottom and to a point 8 inches above the top of the pipe shall be imported fill per Section entitled "Excavation and Backfill for Utilities". Compact by means of vibratory equipment or by flooding. Apply backfill in layers having a maximum thickness of 8 inches. If water flooding is used, do not add successive layers unless the previous layer is compacted to 90% relative compaction.

### 3.08 INSTALLING ABOVEGROUND PIPE

- A. Install pipe on pipe hangers and supports as detailed on the Drawings and as specified in Section entitled "Pipe Supports". Install pipe without springing, forcing, or stressing the pipe or the adjacent valves and equipment to which the pipe is connected.

### 3.09 PAINTING AND COATING

- A. Coat piping in accordance with requirements of section entitled, "Painting".

### 3.10 HYDROSTATIC TESTING

- A. Perform hydrostatic testing for leakage in accordance with requirements set forth in Section entitled "Pipeline Testing".

- END OF SECTION -

## SECTION 15030 - PIPING AND EQUIPMENT IDENTIFICATION SYSTEMS

### PART 1 -- GENERAL

#### 1.01 THE REQUIREMENT

- A. The CONTRACTOR shall furnish and install all components of the system for identification of piping and equipment as specified hereinafter. The system shall include the application of color coding to all new and altered plant piping. The CONTRACTOR shall paint the equipment and piping of all Contracts in the colors herein specified, and in accordance with the requirements of Section 09900 - Painting.
- B. In addition to the legends specified herein the ENGINEER may order the CONTRACTOR to furnish and install additional identification legends and arrows at no additional cost to the Owner. Such additional signs may be requested near completion of the work and shall be limited to no more than five (5) signs for each type specified herein. The legends and color combinations for additional signs shall conform to the requirements specified herein.
- C. The CONTRACTOR shall submit a schedule of the colors and designations proposed in accordance with Section 01300 - Submittals, and this Section. A minimum of four (4) color charts with cross-references to the colors listed herein shall be included with the Submittal.
- D. Reference Section 15000 - Basic Mechanical Requirements.

### PART 2 -- PRODUCTS

#### 2.01 PIPING BAND

- A. All new and altered piping shall receive identification bands. Such bands shall be 6-inches wide, neatly made by masking, and spaced at intervals of 30-inches on centers regardless of the diameter of the pipe being painted. The CONTRACTOR may use approved precut and prefinished metal bands on piping, in lieu of the masked and painted bands, where approved by the ENGINEER.

#### 2.02 PIPING IDENTIFICATION LEGEND

- A. The CONTRACTOR shall apply identification legends to all types and sections of piping as shown on the Drawings or as designated by the ENGINEER. Such legends shall be in the form of plain block lettering giving the name of the pipe content in full or abbreviated form, and showing the direction of flow by arrows. All lettering and arrows shall be of the plastic snap-on type, Seton nameplate "setmarks", or equal, or they shall be formed by stenciling in an approved manner using white or black as directed and shall have an overall height in inches in accordance with the following table:

<b>Diameter of Pipe or Pipe Covering</b>	<b>Height of Lettering</b>
3/4 to 1-1/4 inches	1/2-inches
1-1/2 to 2-inches	3/4-inches
2-1/2 to 6-inches	1-1/4-inches
8 to 10-inches	2-1/2-inches
Over 10-inches	3-1/2-inches

- B. Identification lettering shall be located midway between color coding bands where possible. Identification lettering and arrows shall be placed as directed by the ENGINEER, but shall generally be located each fifteen (15) feet in pipe length, and shall be properly inclined to the pipe axis to facilitate easy reading. In the event lettering and arrow identifications are required for piping less than 3/4-inch in diameter, the CONTRACTOR shall furnish and attach approved color coded tags where instructed.
- C. Piping and Equipment shall be color coded to match existing. Contractor shall field verify colors and obtain approval from City during shop drawing review.

PART 3 -- EXECUTION

(NOT USED)

- END OF SECTION -

## SECTION 15095 – VALVES, GENERAL

### PART 1 -- GENERAL

#### 1.01 THE REQUIREMENT

- A. The CONTRACTOR shall furnish and install, complete with all assemblies and accessories, all valves shown on the Drawings and specified herein including all fittings, appurtenances and transition pieces required for a complete and operable installation.
- B. The provisions of this Section shall apply to all valves and valve operators specified in the various Sections of these Specifications except where otherwise specified in the Contract Documents. Valves and operators in particular locations may require a combination of units, sensors, limit switches, and controls specified in other sections of these Specifications.

#### 1.02 RELATED WORK SPECIFIED ELSEWHERE

- A. Section 09900 – Painting
- B. Section 11000 – Equipment General Provisions
- C. Section 15000 – Basic Mechanical Requirements

#### 1.03 REFERENCE SPECIFICATIONS, CODES, AND STANDARDS

- A. Codes: All codes, as referenced herein, are specified in Section 01600, Reference Standards.

- B. Commercial Standards:

ASME B16.1	Cast Iron Pipe Flanges and Flanged Fittings, Class 25, 125, 250, and 800.
ANSI B16.5	Pipe Flanges and Flanged Fittings, Steel Nickel Alloy and Other Special Alloys.
ANSI/ASME B1.20.1	General Purpose Pipe Threads (Inch).
ANSI/ASME B31.1	Power Piping.
ASTM A 36	Specification for Structural Steel.
ASTM A 48	Specification for Gray Iron Castings.
ASTM A 126	Specification for Gray Iron Castings for Valves, Flanges, and Pipe Fittings.
ASTM A 536	Specification for Ductile Iron Castings.

ASTM B 61	Specification for Steam or Valve Bronze Castings.
ASTM B 62	Specification for Composition Bronze or Ounce Metal Castings.
ASTM B 148	Specification for Aluminum-Bronze Castings.
ASTM B 584	Specification for Copper Alloy Sand Castings for General Applications.
ANSI/AWWA C500	Metal-Seated Gate Valves for Water Supply Service.
ANSI/AWWA C504	Rubber-Seated Butterfly Valves.
AWWA C508	Swing-Check Valves for Waterworks Service, 2 Inches Through 24 Inches NPS.
ANSI/AWWA C509	Resilient-Seated Gate Valves for Water Service.
AWWA C550	Protective Interior Coatings for Valves and Hydrants.

#### 1.04 CONTRACTOR SUBMITTALS

- A. Shop Drawings: Shop Drawings conforming to the requirements of Section 01300, Submittals, are required for all valves, and accessories. Submittals shall include all layout dimensions, size and materials of construction for all components, information on support and anchoring where necessary, pneumatic and hydraulic characteristics and complete descriptive information to demonstrate full compliance with the Documents. Shop Drawings for electrically operated/controlled valves shall include all details, notes, and diagrams which clearly identify required coordination with the electrical power supply and remote status and alarm indicating devices. Electrical control schematic diagrams shall be submitted with the Shop Drawings for all electrical controls. Diagrams shall be drawn using a ladder-type format in accordance with JIC standards. Shop Drawings for pneumatically operated/controlled valves shall include all details, notes, and diagrams which clearly identify required coordination with the compressed air (service air) system and electrical controls.
- B. Operation and Maintenance Manuals: Operation and maintenance manuals and installation instructions shall be submitted for all valves and accessories in accordance with the Specifications. The manufacturer(s) shall delete all information which does not apply to the equipment being furnished.
- C. Valve Labeling: The CONTRACTOR shall submit a schedule of valves to be labeled indicating in each case the valve location and the proposed wording for the label.

#### 1.05 QUALITY ASSURANCE

- A. Valve Testing: Unless otherwise specified, each valve body shall be tested under a test pressure equal to twice its design water-working pressure.
- B. Bronze Parts: Unless otherwise specified, all interior bronze parts of valves shall conform to the requirements of ASTM B 62, or, where not subject to dezincification, to ASTM B 584.

## PART 2 -- PRODUCTS

### 2.01 VALVES

- A. General: The CONTRACTOR shall furnish all valves, valve- operating units, stem extensions, and other accessories as shown or specified. All valves shall be new and of current manufacture. All shut-off valves, 6-inch and larger, shall have operators with position indicators. Where buried, these valves shall be provided with valve boxes and covers containing position indicators, and valve extensions. Shut-off valves mounted higher than 6-feet above working level shall be provided with chain operators. All valves shall have a minimum design pressure rating of 150 psi and capable of a test pressure of 300 psi. For service applications with pressures in excess of 150 psi, valves shall have a minimum pressure rating in excess of the service application working pressure.
- B. Materials: All valves shall be constructed of first quality materials which have strength, wearing, and corrosion resistance characteristics entirely suitable for the types of service for which the individual valves are designated. Cast iron parts of valves shall meet the requirements of ASTM A 126, "Standard Specifications for Grey Iron Castings for Valves, Flanges and Pipe Fittings, Class 'B'." All castings shall be clean and sound, without defects of any kind and no plugging, welding or repairing of defects will be permitted. Nonferrous alloys of various types shall be used for parts of valves as specified. Where no definite specification is given, the material shall be the recognized acceptable standard for that particular application.
- C. End Connections: Valves shall have flanged ends for exposed service and mechanical joint ends for buried service, unless otherwise shown on the Drawings or specified herein.
- D. All buried valves shall be provided with cast-iron valve boxes unless otherwise indicated. The boxes shall be asphalt varnished, or enameled cast iron, adjustable to grade, and installed perpendicularly, centered around and covering the upper portions of the valve or valve operator, or the pipe. The top of each valve box shall be placed flush with finish grade unless otherwise indicated on the Drawings. Valve boxes shall be as specified elsewhere in this section.
- E. All buried valves and other valves located below the concrete operating deck or level, specified or noted to be key operated, shall have an operator to finish grade or deck level, a 2-inch square AWWA operating nut, and cover or box and cover, as may be required.
- F. Valve Flanges: Flanged ends shall be flat-faced and have bolt circle and bolt patterns conforming to ANSI B16.1 Class 125 unless otherwise specified hereinafter. All bolt heads and nuts shall be hexagonal conforming to ANSI B18.2. Gaskets shall be full face and made of natural or synthetic elastomers in conformance with ANSI B16.21 suitable for the service characteristics, especially chemical compatibility and temperature.
- G. Gate Valve Stems: Where subject to dezincification, gate valve stems shall be of bronze to ASTM B 62, containing not more than 5 percent of zinc or more than 2 percent of aluminum. Where dezincification is not a problem, bronze to ASTM B 584 may be used. For valve stems with a minimum tensile strength of 60,000 psi, a minimum yield strength of 40,000 psi, and an elongation of at least 10 percent in 2 inches, as determined by a test coupon poured from the same ladle from which the valve stems to be furnished are poured.

- H. Protective Coating: Except where otherwise specified, ferrous surfaces, exclusive of stainless steel surfaces, in the water passages of all valves 4-inch and larger, as well as the exterior surfaces of all submerged valves, shall receive a fusion-bonded epoxy coating in accordance with AWWA C550. Flange faces of valves shall not be epoxy coated. The CONTRACTOR, through the valve manufacturer, shall certify in writing that such coating has been applied and tested in the manufacturing plant prior to shipment, in accordance with these Specifications.
- I. Valve Operators: Valves and gates shall be furnished with operators, provided by the valve or gate manufacturer. All operators of a given type shall be furnished by the same manufacturer. All valve operators, regardless of type, shall be installed, adjusted, and tested by the valve manufacturer at the manufacturing plant. Operator orientation shall be verified with the ENGINEER prior to installation. If this requirement is not met, changes to orientation shall be made at no additional cost.
- J. All operators, unless otherwise specified, shall turn counter-clockwise to open. Operators shall have the open direction clearly and permanently marked. All valve operators, shall be provided with the valve by the valve manufacturer. The CONTRACTOR, through the valve manufacturer, shall be solely responsible for the selection of the proper operator to meet the operating conditions specified herein. Field calibration and testing of the operators and valves to ensure proper installation and operation shall be the responsibility of the CONTRACTOR.
- K. All manual operators shall have levers or handwheels, unless otherwise shown. Where buried, the valves shall have extensions with square nuts or floor stands. Valves mounted higher than 6 feet above floor or operating level shall have chain operators. Unless otherwise shown or specified, valves of sizes 4-inch and larger shall have gear-assisted operators.
- L. Operation of valves and gates shall be designed so that the effort required to operate the handwheel, lever or chain shall not exceed 40 pounds applied at the extremity of the wheel or lever. The handwheels on valves 14 inches and smaller shall not be less than 8 inches in diameter, and on valves larger than 14 inches the handwheel shall not be less than 12 inches in diameter.
- M. Chainwheel operator shall be fabricated of malleable iron and pocketed type chainwheels with chain guards and guides. Chainwheel operators shall be marked with an arrow and the word "OPEN" indicating direction to open. Indicators shall be provided at ground level. The operators shall have galvanized smooth welded link type chain. Chain that is crimped or has links with exposed ends shall not be acceptable.
- N. Floor Stands: Floor stands shall be cast iron, non-rising stem type with lockable hand wheel operator, valve position indicator and steel extension stem. Hand wheel shall be lockable in the full closed position. The floor stand shall be furnished with an armored padlock and six keys. Lock shall be as manufactured by Master, Schlage or equal. Floor stand shall be standard pattern type as manufactured by Clow Corporation, or equal.
- O. Valve Labeling: A label shall be provided on all shut-off valves exclusive of hose bibbs and chlorine cylinder valves. The label shall be of 1/16-inch bronze or stainless steel, minimum 2 inches by 4 inches in size, and shall be permanently attached to the valve or on the wall adjacent to the valve or as indicated by the ENGINEER.

## 2.02 VALVE BOXES

- A. The CONTRACTOR shall furnish and install valve boxes as shown on the Drawings and specified herein.
- B. All valve boxes shall be placed so as not to transmit shock or stress to the valve and shall be centered and plumb over the operating nut of the valve. The ground in the trench upon which the valve boxes rest shall be thoroughly compacted to prevent settlement. The boxes shall be fitted together securely and set so that the cover is flush with the finished grade of the adjacent surface. A concrete pad as detailed on the Drawings shall be provided around the valve box, sloped outwards.
- C. All valve boxes shall be 2-piece cast iron, sliding type, 5-1/4" shaft, with heavy duty traffic weight collar and the lid marked with the appropriate carrier product (i.e.: WATER). Boxes shall be as manufactured by Tyler Union, or equal.

## PART 3 -- EXECUTION

### 3.01 VALVE INSTALLATION

- A. General: Before installation, all valves shall be lubricated, manually opened and closed to check their operation and the interior of the valves shall be thoroughly cleaned. Valves shall be placed in the positions shown on the Drawings.
- B. All valves, operating units, stem extensions, valve boxes, and accessories shall be installed in accordance with the manufacturer's written instructions and as shown and specified. Valves shall be firmly supported to avoid undue stresses on the pipe.
- B. Access: Install all valves so that operating handwheels or wrenches may be conveniently turned from operating floor but without interfering with access, and and to avoid conflicts between valve operators and structural members or handrails. Unless otherwise approved, install all valves plumb and level. All valves shall be installed to provide easy access for operation, removal, and maintenance.
- C. Valve Accessories: Where combinations of valves, sensors, switches, and controls are specified or shown on the drawings, it shall be the responsibility of the CONTRACTOR to properly assemble and install these various items so that all systems are compatible and operating properly. The relationship between interrelated items shall be clearly noted on shop drawing submittals.
- D. Valve boxes shall be set plumb, and centered with the bodies directly over the valves so that traffic loads are not transmitted to the valve. Earth fill shall be carefully tamped around each valve box to a distance of 4 feet on all sides of the box, or to the undisturbed trench face, if less than 4 feet.
- E. All valves shall be tested at the operating pressures at which the particular line will be used. Any leakage or "sweating" of joints shall be stopped, and all joints shall be tight. All motor operated and cylinder operated valves shall be tested for control operation as directed by the ENGINEER.

- END OF SECTION -



## SECTION 15104 - BALL VALVES

### PART 1 -- GENERAL

#### 1.01 THE REQUIREMENT

- A. The CONTRACTOR shall furnish and install ball valves, complete and operable, as shown and specified herein, including epoxy coating, appurtenances, operators, and accessories, all in accordance with the requirements of the Contract Documents.

#### 1.02 RELATED WORK SPECIFIED ELSEWHERE

- A. Section 15095 - Valves, General

#### 1.03 SUBMITTALS

- A. Shop Drawings: Submit shop drawings in accordance with the section entitled "Submittals." The shop drawings shall include the following:
  - 1. Manufacturer's standard literature.
  - 2. Dimension drawings for all valves to be supplied.
  - 3. Valve manufacture's recommended instructions for joining the valves and piping.
- B. Operation and Maintenance Manuals: Submit operation and maintenance manuals in accordance with the section entitled "Submittals".

### PART 2 -- PRODUCTS

#### 2.01 PLASTIC BALL VALVES

- A. Plastic ball valves shall be used at all PVC pipe installations where required, and be made of polyvinyl chloride (PVC) or chlorinated polyvinyl chloride (CPVC) as recommended by the Supplier for any specific applications. PVC shall be Class 12454-B or better, conforming to resin specification ASTM D1784. CPVC shall be Class 23447-B or better, conforming to resin specification ASTM D1784. All valves shall have manual operators, unless otherwise specified or shown.
- B. All plastic ball valves shall have socket true union ends or flanged ends to ANSI B 16.5, class 150, for easy removal. The balls shall have full size ports and PTFE seats and shall be polished free of any imperfections. PTFE seats shall have elastomeric backing cushion of the same material as the valve seals. All body seals, union O-ring seals, and stem seals shall be Viton. The valves shall be suitable for a maximum working non-shock pressure of 230 psi at 73 degrees F for sizes 1/2" through 2" and 150 psi at 73 degrees F for sizes 2-1/2" through 6". The handle shall incorporate a tool for adjustment of the seat carrier.
- C. Suppliers or Equal

1. ASAHI-America;
2. IPEX;
3. Plast-o-matic.

## 2.02 STAINLESS STEEL BALL VALVES

- A. Ball valves for use with stainless steel piping systems, including instrument isolation, air lines, and moisture drains shall be end entry type with type 316 stainless steel body and trim, Teflon seats and seals and flanged or threaded connections as indicated. Valve body shall be either two or three piece design, no internal ring for the ball shall be acceptable. Valves shall be class 150.
- B. Valves shall be supplied with stainless steel manual lever or "T" handle. Valves used as moisture drain valves shall be installed at low points of the line and piped to drain.
- C. Suppliers, or Equal
  1. Jamesbury Corporation;
  2. Jenkins Bros.;
  3. Lunkenheimer Flow Control;
  4. Wm. Powell Company;
  5. Worcester Controls.

## PART 3 -- EXECUTION

### 3.01 GENERAL

- A. All valves shall be installed in accordance with provisions of Section 15095 entitled "Valves, General." Care shall be taken that all valves in plastic lines are well supported on each end of the valve.
- B. All valves shall be tested to unidirectional or bi-directional shut-off as required by service conditions.

- END OF SECTION -

## SECTION 15109 - PLUG VALVES

### PART 1 -- GENERAL

#### 1.01 THE REQUIREMENT

- A. The CONTRACTOR shall furnish and install plug valves, complete and operable, as shown on the Drawings and as specified herein including operators, protective coatings, and appurtenant work, all in accordance with the requirements of the Contract Documents.

#### 1.02 RELATED WORK SPECIFIED ELSEWHERE

- A. Section 15095 - Valves, General.

### PART 2 -- PRODUCTS

#### 2.01 PLUG VALVES

- A. Eccentric Plug Valves 3"-36" shall meet or exceed the latest revision of AWWA Standard C517, and shall meet or exceed the requirements of this specification. Plug valves shall be of the non-lubricated, eccentric seating plug type with synthetic rubber-faced plugs as manufactured by DeZurik Company. Valves shall be PEF 100% port area, unless otherwise specified herein or indicated in the appropriate Valve Schedule in Section 15390, Schedules. All valves shall be provided with limit stops and rotate 90° from fully open to fully shut. The minimum working pressure for all valves shall be 150 psi, and the test pressure shall be at least 270 psi for valves up through 12-inch and at least 230 psi for valves 14-inch and larger. The body materials shall be of epoxy coated cast iron or semi-steel, unless specified otherwise. Seats shall have a welded overlay of 90 percent pure nickel and machined to a finish containing no stress cracks. Plug facings shall be of Hycar, or equal and completely suitable for use with domestic sewage.
- B. Full port (100% of full pipe area) plug valves shall be furnished for all sludge applications.
- C. The shaft seal shall be either the bronze cartridge type with at least two O-Rings, monolithic V-Type, or pull down packing type. If monolithic V-Type or pull down packings are utilized, it shall be self-adjusting, self-compensating type. Packing shall be as Chevron Type, or equal. Plug valves with pull down packings shall be designed with an extension bonnet so that repacking can be done without removal of the actuator.
- D. All buried valves shall have mechanical joint ends (unless otherwise shown), conforming to AWWA C111, and shall be operated with a standard AWWA 2-inch square nut through a totally enclosed worm gear actuator. Valve boxes shall be installed with all buried plug valves and shall be as specified herein.
- E. Unless otherwise shown, all exposed valves 4-inches in diameter and larger shall have flanged ends conforming to ASME B16.1-125/150 pound standard with face-to-face dimensions of standard plug valves. Valves smaller than 4-inches in diameter shall have screwed ends, unless otherwise noted.

- F. Valves 6-inches in diameter and larger shall be handwheel or floorstand operated where required or indicated on the Drawings through totally enclosed worm gear actuators, unless otherwise specified or shown on the Drawings. Valves 6-inches in diameter and smaller shall have lever operators, unless otherwise specified or noted on the Drawings. Manual operators for plug valves mounted above 6 feet from the operating floor shall be equipped with worm gear chainwheel actuators. Electric, electrohydraulic and pneumatic actuators shall be mounted to the valve by the valve supplier.
- G. The manufacturer shall certify that the plug valves are capable of operating in continuous duty service under these pressures and flow conditions.
- H. Each valve shall be hydrostatically tested and tested for bubble tightness after the operator has been mounted and adjusted. Copies of the hydrostatic and leakage test certification and certification of conformance shall be submitted to the ENGINEER prior to shipment.
- I. All internal and external ferrous components and surfaces of the valves, with the exception of stainless steel and finished or bearing surfaces, shall be shop painted with two coats (10 mils min. dry film thickness) of the manufacturer's premium epoxy for corrosion resistance. Damaged surfaces shall be repaired in accordance with the manufacturer's recommendations.

## 2.02 MOTORIZED VALVE ACTUATORS (NOT USED)

### PART 3 -- EXECUTION

#### 3.01 INSTALLATION

- A. All plug valves shall be installed in strict accordance with the Supplier's published recommendations and the applicable provisions of the Section, titled "Valves, General".

- END OF SECTION -

## SECTION 15114 - MISCELLANEOUS VALVES AND APPURTENANCES

### PART 1 -- GENERAL

#### 1.01 THE REQUIREMENT

- A. Reference Section 15000, Basic Mechanical Requirements.

### PART 2 -- PRODUCTS

#### 2.01 GATE VALVES (SMALLER THAN 4-INCH)

- A. Gate valves, smaller than 4-inch, for general purpose use shall be heavy duty type for industrial service, with screwed or soldered ends to suit piping. The bodies shall have screwed tops or union bonnets, of bronze to ASTM B 62, with bronze stems, solid wedges, metal handwheels, and Teflon-impregnated or other acceptable packing. Buried valves shall have non-rising stems. Exposed valves (above ground) shall have rising stems. All valves shall have a minimum pressure rating of 125 psi.
- B. Suppliers, or Equal:
  - 1. Crane Company;
  - 2. Milwaukee Valve Company;
  - 3. Wm. Powell Company.

#### 2.02 SERVICE SADDLES

- A. Service pipe saddle shall fit to the maximum O.D. of the saddle's range, and extend a minimum of 160 degrees around the pipe. When the saddle is used on pipe to the minimum pipe size of the range, the saddle shall extend 180 degrees around the pipe. Straps shall have ends chamfered and be provided with Class 2 fit, National Coarse Threads. Saddle casting shall be ductile iron, double strap and shall have asphaltic coating. Straps shall be stainless steel. Valve gaskets shall be self sealing, neoprene.

#### 2.03 CORPORATION STOPS

- A. Corporation stops shall be provided with all service saddle connections. Corporation stops shall be O-ring sealed, balance pressure, plug type valves having a full open unobstructed flow way. Corporation stops shall have threaded inlet and outlet connections unless otherwise indicated and shall be suitable for buried service where required. Corporation stops shall be manufactured of brass alloys containing less than 0.25% lead.
- B. The suppliers shall be the following or equal:
  - 1. Ford Meter Box Company;
  - 2. James Jones Company;

3. Mueller Company.

2.03 SOLENOID VALVES

- A. Three-way two-position solenoid valves shall be of the two coil type. Both coils shall be normally closed and each shall open independently when energized. The valve shall be of forged brass-body and bonnet with a Buna "N" diaphragm and screwed ends. The solenoid's internal parts shall be of 300 and 400 series stainless steel. The valve shall have a safe body working pressure of 125 psi and shall be as manufactured by ASCO Valves, Automatic Switch Co., or equal, for 120V, 60 Hz, single phase operation. Solenoid enclosure shall be NEMA 4 watertight.
- B. Two-way solenoid valves shall be normally closed and shall open when the solenoid is energized, unless otherwise noted. The valve shall be of forged brass-body and bonnet with a BUNA "N" diaphragm and screwed ends. The solenoid's internal parts shall be of 300 and 400 series stainless steel. The valve shall have a safe body working pressure of 125 psi, and shall be as manufactured by ASCO Valves, Automatic Switch Co., or equal, for 120 volt, 60 Hz, single phase operation. Solenoid enclosure shall be NEMA 4 watertight.
- C. Four-way two-position solenoid valves shall be of the single coil type and shall be normally closed and shall open when the solenoid is energized (i.e. fail closed). The remainder of the four-way two-position solenoid valves shall be of the two coil type. Both coils shall be normally closed and each shall open independently when energized. The valve shall be of forged brass-body and bonnet with a Buna "N" diaphragm and screwed ends. The solenoid's internal parts shall be of 300 and 400 series stainless steel. The valve shall have a safe body working pressure of 125 psi and shall be as manufactured by ASCO Valves, Automatic Switch Co. or equal, for 120V, 60 Hz, single phase operation. Solenoid enclosure shall be NEMA 4 watertight. The solenoid valve shall be provided with a manual override.

2.02 SEWAGE AIR RELEASE VALVES

- A. The Contractor shall furnish and install sewage air release valves where indicated on the Drawings and specified herein. Air release valves for sewage shall have elongated, cylindrical chambers designed to release entrained air and sewage gases through an air release orifice. The air release valve float shall withstand an external pressure of 500 psi without collapsing.
- B. After entraining air escapes through the orifice, the orifice shall be closed by a needle on a compound lever mechanism to prevent the escape of sewage. The orifice shall remain closed until more gas accumulates and the cycle automatically repeats. The valve shall seat to prevent sewage from leaking through the valve at any pressure. Valves shall have an operating pressure of at least 150 psi.
- C. Air release valves shall be provided with a ½" diameter orifice and each valve shall be provided with an isolation valve, quick disconnect coupling and valve for back flushing, and a blow off outlet and valve at the bottom of the chamber.
- D. Materials of construction shall be as follows:

- |                               |  |
|-------------------------------|--|
| 1. Body                       | Cast Iron: ASTM A 126 Grade B or<br>Ductile Iron: ASTMA536 |
| 2. Internal Linkage and Float | Stainless Steel: Type 316                                  |
| 3. Needle                     | Buna-N   |

- E. Sewage air release valves shall have inlets of the type and diameter as shown on the Drawings. If not identified, sewage air release valves shall be provided with a 2-inch (minimum) threaded connection.
- F. All internal and external ferrous components and surfaces of the valves, with the exception of stainless steel and finished or bearing surfaces, shall be shop painted with two coats (10 mils min. dry film thickness) of the manufacturer's premium (NSF approved) epoxy for corrosion resistance. Damaged surfaces shall be repaired in accordance with the manufacturer's recommendations.
- G. Sewage air release valves shall be APCO Series 450 or equivalent as manufactured by ARI, Crispin (S Series), Val-Matic (49A.4 – 49A.6), or equal.

### 2.03 NEEDLE VALVES

- A. Needle valves shall be bronze body and spindle with follower gland and shall be 400 psi, non-shock cold water needle valves, Figure 743-G as manufactured by Jenkins Bros., Corp., Crane Co. No. 88, or equal.
- B. Needle valves (service air) shall be bronze body, with stainless steel stem. Valves shall be Jenkins Valve Fig. 741G, Crane Co. or equal and shall have minimum 400 psi non-shock cold water pressure rating and screwed ends.

## PART 3 – EXECUTION

### 3.01 INSTALLATION

- A. All valves shall be installed in accordance with the manufacturer's printed recommendations and the requirements of Section entitled "Valves, General".

- END OF SECTION -

## SECTION 15995 - PIPELINE TESTING

### PART 1 – GENERAL

#### 1.01 THE REQUIREMENT

- A. The CONTRACTOR shall perform flushing and testing of all pipelines and appurtenant piping, complete, including conveyance of test water from CITY-designated source to point of use and all disposal thereof, all in accordance with the requirements of the Contract Documents.

#### 1.02 REFERENCE SPECIFICATIONS, CODES, AND STANDARDS

##### A. Commercial Standards

ANSI / AWWA B300	Hypochlorites
ANSI / AWWA B301	Liquid Chlorine
ANSI / AWWA C651	Disinfecting Water Mains

#### 1.03 SUBMITTALS

- A. A testing schedule, including proposed plans for water conveyance, control, and disposal shall be submitted in writing for approval a minimum of seven (7) days before testing is to start.
- B. The CONTRACTOR shall submit hydrostatic test reports in accordance with Sections entitled "Submittals" and "Project Closeout".

### PART 2 – PRODUCTS

#### 2.01 MATERIALS REQUIREMENTS

- A. All test equipment, temporary valves or bulkheads, temporary vents or drains, or other water control equipment and materials shall be determined and furnished by the CONTRACTOR subject to the CITY'S review. No materials shall be used which would be injurious to the construction or its future function.

### PART 3 – EXECUTION

#### 3.01 GENERAL

- A. Notify the ENGINEER and CITY 48 hours in advance to obtain CITY'S approval to commence testing and/or disinfection of any particular structure and/or pipeline.
- B. Unless otherwise provided herein, water for flushing and testing pipelines will be furnished by the CITY; however, the CONTRACTOR shall make all necessary provisions for conveying the water from the CITY-designated source to the points of use.



- C. All pressure and gravity pipelines shall be tested. All testing operations shall be performed in the presence of the CITY.

### 3.02 FLUSHING

- A. At the conclusion of the installation work, the CONTRACTOR shall thoroughly clean all new liquid conveying pipe by flushing with water or other means to remove all dirt, stones, pieces of wood, etc., which may have entered the pipe during the construction period. If after this cleaning any obstructions remain, they shall be corrected by the Contractor, at his own expense, to the satisfaction of the CITY. Liquid conveying pipelines shall be flushed at the rate of at least 2.5 feet per second for a duration suitable to the CITY or shall be flushed by other methods approved by the CITY.

### 3.03 HYDROSTATIC TESTING OF PIPING

- A. Following pipeline flushing, the CONTRACTOR shall hydrostatically test all pipelines either in sections or as a unit. No section of the pipeline shall be tested until all field-placed concrete or mortar have attained an age of 14 days. The test shall be made by closing valves when available, or by placing temporary bulkheads in the pipe and filling the line slowly with water. The CONTRACTOR shall be responsible for ascertaining that all test bulkheads are suitably restrained to resist the thrust of the test pressure without damage to, or movement of, the adjacent pipe. Care shall be taken to see that all air vents are open during filling.
- B. The pipeline shall be filled at a rate which will not cause any surges or exceed the rate at which the air can be released through the air valves at a reasonable velocity and all the air within the pipeline shall be properly purged. After the pipeline or section thereof has been filled, it shall be allowed to stand under a slight pressure for at least 24 hours to allow the concrete or mortar lining, as applicable, to absorb what water it will and to allow the escape of air from any air pockets. During this period, bulkheads, valves, and connections shall be examined for leaks. If leaks are found, corrective measures satisfactory to the CITY shall be taken.
- C. The test pressure for the hydrostatic test shall be as specified in Section 15390 – Pipe Schedule.
- D. The hydrostatic test shall consist of holding the test pressure on the pipeline for a period of 4 hours. All visible leaks shall be repaired in a manner acceptable to the CITY.
- E. The maximum allowable leakage shall be determined by the following formula:

$$L = \frac{SD\sqrt{P}}{1000}$$

- where D = Pipe diameter in inches  
S = Length of lines in lineal feet  
P = Average test pressure  
L = Allowable leakage for system in gallons per hour

In the case of pipelines that fail to pass the prescribed leakage test, the CONTRACTOR shall determine the cause of the leakage, shall take corrective measures necessary to repair the leaks, and shall again test the pipelines. The CONTRACTOR shall provide all

reaction blocking and necessary plugs and caps required to test all piping installed as part of this Contract.

- F. The CONTRACTOR shall submit to the CITY a detailed description of the testing procedures to be utilized.

-END OF SECTION-

**DIVISION 16 – ELECTRICAL**

## SECTION 16000 - BASIC ELECTRICAL REQUIREMENTS

### PART 1 -- GENERAL

#### 1.01 THE REQUIREMENT

- A. The Contractor shall furnish all labor, materials, tools, and equipment, and perform all work and services necessary for, or incidental to, the furnishing and installation of all electrical work as shown on the Drawings, and as specified in accordance with the provisions of the Contract Documents and completely coordinate with the work of other trades involved in the general construction. Although such work is not specifically shown or specified, all supplementary or miscellaneous items, appurtenances, and devices incidental to or necessary for a sound, secure, and complete installation shall be furnished and installed as part of this work. The Contractor shall obtain approved Shop Drawings showing wiring diagrams, connection diagrams, roughing-in and hook up details for all equipment and comply therewith. All electrical work shall be complete and left in operating condition in accordance with the intent of the Drawings and the Specifications for the electrical work.
- B. Reference Section 17000, Control and Information System Scope and General Requirements for scope of work details as they relate to the Division 17 Subcontractor.
- C. The electrical scope of work for this project primarily includes, but is not limited to, the following:
  - 1. Demolish existing control panels, instruments, wiring, raceway, and mounting hardware associated with Clarifier No. 3 mechanism, as indicated on the drawings.
  - 2. Furnish and install new Control Panel for Clarifier No. 3.
  - 3. Modify existing motor starter controls for Clarifier No. 3, as required to provide the desired functionality.
  - 4. Furnish and install all aboveground raceway systems including conduit, fittings, boxes, supports, and other pertinent components.
  - 5. Furnish and install all low voltage wire and cable resulting in a complete and operable electrical system.
  - 6. Furnish and install new shock relay control panel and associated conduit and wiring for Clarifier No. 3 in RAS Pump Station 2 electrical room.
  - 7. Other electrical work as specified herein and indicated on the Drawings.
- D. All material and equipment must be the product of an established, reputable, and approved manufacturer; must be new and of first-class construction; must be designed and guaranteed to perform the service required; and must bear the label of approval of the Underwriters Laboratories, Inc., where such approval is available for the product of the listed manufacturer as approved by the Engineer.

- E. When a specified or indicated item has been superseded or is no longer available, the manufacturer's latest equivalent type or model of material or equipment as approved by the Engineer shall be furnished and installed at no additional cost to the Owner.
- F. Where the Contractor's selection of equipment of specified manufacturers or additionally approved manufacturers requires changes or additions to the system design, the Contractor shall be responsible in all respects for the modifications to all system designs, subject to approval of the Engineer. The Contractor's bid shall include all costs for all work of the Contract for all trades made necessary by such changes, additions or modifications or resulting from any approved substitution.
- G. Furnish and install all stands, racks, brackets, supports, and similar equipment required to properly serve the equipment which is furnished under this Contract, or equipment otherwise specified or indicated on the Drawings.

#### 1.02 EQUIPMENT LOCATION

- A. The Drawings show the general location of feeders, transformers, outlets, conduits, and circuit arrangements. Because of the small scale of the Drawings, it is not possible to indicate all of the details involved. The Contractor shall carefully investigate the structural and finish conditions affecting all of his work and shall arrange such work accordingly; furnishing such fittings, junction boxes, and accessories as may be required to meet such conditions. The Contractor shall refer to the entire Drawing set to verify openings, special surfaces, and location of other equipment, or other special equipment prior to roughing-in for panels, switches, and other outlets. The Contractor shall verify all equipment dimensions to ensure that proposed equipment will fit properly in spaces indicated.
- B. Where outlets are shown near identified equipment furnished by this or other Contractors, it is the intent of the Specifications and Drawings that the outlet be located at the equipment to be served. The Contractor shall coordinate the location of these outlets to be near the final location of the equipment served whether placed correctly or incorrectly on the Drawings.

#### 1.03 LOCAL CONDITIONS

- A. The Contractor shall examine the site and become familiar with conditions affecting the work. The Contractor shall investigate, determine, and verify locations of any overhead or buried utilities on or near the site, and shall determine such locations in conjunction with all public and/or private utility companies and with all authorities having jurisdiction.

#### 1.04 SUBMITTALS

- A. In accordance with the procedures and requirements set forth in the General Conditions, Section 01300 – Submittals, and the requirements of the individual specification sections, the Contractor shall obtain from the equipment manufacturer and submit the following:
  - 1. Shop Drawings
  - 2. Operation and Maintenance Manuals
  - 3. Spare Parts List
  - 4. Proposed Testing Methods and Reports of Certified Shop Tests.

5. Reports of Certified Field Tests.

6. Manufacturer's Representative's Certification.

B. Submittals shall be sufficiently complete in detail to enable the Engineer to determine compliance with Contract requirements.

C. Submittals will be approved only to the extent of the information shown. Approval of an item of equipment shall not be construed to mean approval for components of that item for which the Contractor has provided no information.

#### 1.05 APPLICABLE CODES AND REQUIREMENTS

##### A. Conformance

1. All work, equipment and materials furnished shall conform with the existing rules, requirements and specifications of the following:

a. Insurance Rating Organization having jurisdiction

b. The serving electrical utility company

c. The currently adopted edition of the National Electrical Code (NEC)

d. The National Electric Manufacturers Association (NEMA)

e. The Institute of Electrical and Electronic Engineers (IEEE)

f. The Insulated Cable Engineers Association (ICEA)

g. The American Society of Testing Materials (ASTM)

h. The American National Standards Institute (ANSI)

i. The requirements of the Occupational Safety Hazards Act (OSHA)

j. The National Electrical Contractors Association (NECA) Standard of Installation

k. National Fire Protection Association (NFPA)

l. International Electrical Testing Association (NETA)

m. All other applicable Federal, State and local laws and/or ordinances.

2. All material and equipment shall bear the inspection labels of Underwriters Laboratories, Inc., if the material and equipment is of the class inspected by said laboratories.

##### B. Nonconformance

1. Any paragraph of requirements in these Specifications, or Drawings, deviating from the rules, requirements and Specifications of the above organizations shall be invalid and their (the above organizations) requirements shall hold precedent

thereto. The Contractor shall be held responsible for adherence to all rules, requirements and specifications as set forth above. Any additional work or material necessary for adherence will not be allowed as an extra, but shall be included in the Bid. Ignorance of any rule, requirement, or Specification shall not be allowed as an excuse for nonconformity. Acceptance by the Engineer does not relieve the Contractor from the expense involved for the correction of any errors which may exist in the drawings submitted or in the satisfactory operation of any equipment.

C. Certification

1. Upon completion of the work, the Contractor shall obtain certificate(s) of inspection and approval from the National Board of Fire Underwriters or similar inspection organization having jurisdiction and shall deliver same to the Engineer and the Owner.

1.06 PERMITS AND INSPECTIONS

- A. The Contractor shall reference the General Conditions and Section 01010, Summary of Work.

1.07 TEMPORARY LIGHTING AND POWER

- A. The Contractor shall reference the General Conditions and Section 01510, Utilities & Services.

1.08 TESTS

- A. Upon completion of the installation, the Contractor shall perform tests for operation, load (Phase) balance, overloads, and short circuits. Tests shall be made with and to the satisfaction of the Owner and Engineer.
- B. The Contractor shall perform all field tests and shall provide all labor, equipment, and incidentals required for testing and shall pay for electric power required for the tests. All defective material and workmanship disclosed shall be corrected by the Contractor at no cost to the Owner. The Contractor shall show by demonstration in service that all circuits and devices are in good operating condition. Test shall be such that each item of control equipment will function not less than five (5) times.
- C. Refer to each individual specification section for detailed test requirements.
- D. The Contractor shall complete the installation and field testing of the electrical installation at least two (2) weeks prior to the start-up and testing of all other equipment. During the period between the completion of electrical installation and the start-up and testing of all other equipment, the Contractor shall make all components of the Work available as it is completed for their use in performing Preliminary and Final Field Tests.
- E. Before each test commences, the Contractor shall submit a detailed test procedure, and also provide test engineer resume, manpower and scheduling information for the approval by the Engineer. In addition, the Contractor shall furnish detailed test procedures for any equipment required as part of the field tests of other systems.

## 1.09 INFRARED INSPECTION

- A. Just prior to the final acceptance of a piece of equipment, the Contractor shall perform an infrared inspection to locate and correct all heating problems associated with electrical equipment terminations. The infrared inspection shall be performed by a third party, independent testing agency, not the Electrical Contractor.
- B. The infrared inspection shall apply to all new equipment and existing equipment that is in any way modified under this Contract. All heating problems detected with new equipment furnished and installed under the Scope of this Contract shall be corrected by the Contractor. All problems detected with portions of existing equipment modified under this Contract shall also be corrected by the Contractor.
- C. Any issues detected with portions of existing equipment that were not modified under this Contract are not the responsibility of the Contractor. Despite the Contractor not being held responsible for these problems, the Contractor shall report them to the Owner and Engineer immediately for resolution.
- D. The infrared inspection report shall include both digital and IR pictures positioned side by side. Both the digital and IR pictures shall be clear and high quality. Fuzzy, grainy, or poorly illuminated pictures are not acceptable. The IR picture shall be provided with a temperature scale beside it, and an indication of the hot spot temperature in each picture. Reports shall be furnished in a 3-ring binder, with all pages printed in full color, with equipment assemblies separated by tabs.

## 1.10 PROTECTIVE DEVICE SETTING AND TESTING

- A. The Contractor shall provide the services of a qualified, independent, third party testing company using N.E.T.A. certified technicians to adjust, set, calibrate and test all protective devices in the electrical system. The company shall not be a subsidiary of the electrical equipment manufacturer. The qualifications of the testing company and resumes of the technicians as well as all data forms to be used for the field testing shall be submitted.
- B. All protective devices in the electrical equipment shall be set, adjusted, calibrated and tested in accordance with the manufacturers' recommendations, the coordination study, and best industry practice.
- C. Proper operation of all equipment associated with the device under test and its compartment shall be verified, as well as complete resistance, continuity and polarity tests of power, protective and metering circuits. Any minor adjustments, repairs and/or lubrication necessary to achieve proper operation shall be considered part of this Contract.
- D. All solid state trip devices shall be checked and tested for setting and operation using manufacturers recommended test devices and procedures.
- E. Circuit breakers and/or contactors associated with the above devices shall be tested for trip and close functions with their protective device.



- F. When completed, the Contractor shall provide a comprehensive report for all equipment tested indicating condition, readings, faults and/or deficiencies in same. Inoperative or defective equipment shall be brought immediately to the attention of the Engineer.
- G. Prior to placing any equipment in service, correct operation of all protective devices associated with this equipment shall be demonstrated by field testing under simulated load conditions.

#### 1.11 SCHEDULES AND FACILITY OPERATIONS

- A. All testing procedures and schedules must be submitted to the Engineer for review and approval two (2) weeks prior to any work beginning. When testing has been scheduled, the Engineer must be notified 48 hours prior to any work.
- C. In the event of accidental shutdown of Owner equipment, the Contractor shall notify Owner personnel immediately to allow for an orderly restart of affected equipment.
- D. Maintaining the operation of the facilities during the duration of the construction period is essential and required. The Contractor shall furnish and install temporary equipment as required to maintain facility operation. Reference Section 01520 of the Specifications for construction sequencing and specific operational constraint information.

#### 1.12 MATERIALS HANDLING

- A. Materials arriving on the job site shall be stored in such a manner as to keep material free of rust and dirt and so as to keep material properly aligned and true to shape. Rusty, dirty, or misaligned material will be rejected. Electrical conduit shall be stored to provide protection from the weather and accidental damage. Rigid non-metallic conduit shall be stored on even supports and in locations not subject to direct sun rays or excessive heat. Cables shall be sealed, stored, and handled carefully to avoid damage to the outer covering or insulation and damage from moisture and weather. Adequate protection shall be required at all times for electrical equipment and accessories until installed and accepted. Materials damaged during shipment, storage, installation, or testing shall be replaced or repaired in a manner meeting with the approval of the Engineer. If space heaters are provided in a piece of electrical equipment, they shall be connected to a power source during storage. The Contractor shall store equipment and materials in accordance with Section 01550 - Site Access and Storage.

#### 1.13 WARRANTIES

- A. Unless otherwise specified in an individual specification section, all equipment and electrical construction materials furnished and installed under Division 16 shall be provided with a warranty in accordance with the requirements of Section 11000 - Equipment General Provisions, and the General Conditions.

## 1.14 TRAINING

- A. Unless otherwise specified in an individual specification section, all training for equipment furnished and installed under Division 16 shall be provided in accordance with the requirements of Section 11000, Equipment General Provisions.

## PART 2 -- PRODUCTS

### 2.01 PRODUCT REQUIREMENTS

- A. Unless otherwise indicated, the materials to be provided under this Specification shall be the products of manufacturers regularly engaged in the production of all such items and shall be the manufacturer's latest design. The products shall conform to the applicable standards of UL and NEMA, unless specified otherwise. International Electrotechnical Commission (IEC) standards are not recognized. Equipment designed, manufactured, and labeled in compliance with IEC standards is not acceptable.
- B. All items of the same type or ratings shall be identical. This shall be further understood to include products with the accessories indicated.
- C. All equipment and materials shall be new, unless indicated or specified otherwise.
- D. The Contractor shall submit proof if requested by the Engineer that the materials, appliances, equipment, or devices that are provided under this Contract meet the requirements of Underwriters Laboratories, Inc., in regard to fire and casualty hazards. The label of or listing by the Underwriters Laboratories, Inc., will be accepted as conforming to this requirement.

### 2.02 SUBSTITUTIONS

- A. Unless specifically noted otherwise, any reference in the Specifications or on the Drawings to any article, service, product, material, fixture, or item of equipment by name, make, or catalog number shall be interpreted as establishing the type, function, and standard of quality and shall not be construed as limiting competition. The Contractor, in such cases may, at his option use any article, device, product, material, fixture, or item of equipment which in the judgment of the Engineer, expressed in writing, is equal to that specified.

## PART 3 -- EXECUTION

### 3.01 CUTTING AND PATCHING

- A. Coordination
  - 1. The Work shall be coordinated between all trades to avoid delays and unnecessary cutting, channeling and drilling. Sleeves shall be placed in concrete for passage of conduit wherever possible.

B. Damage

1. The Contractor shall perform all chasing, channeling, drilling and patching necessary to the proper execution of his Contract. Any damage to the building, structure, or any equipment shall be repaired by qualified mechanics of the trades involved at the Contractor's expense. If, in the Engineer's judgment, the repair of damaged equipment is unsatisfactory, then the Contractor shall replace damaged equipment at his own expense.

3.02 CORROSION PROTECTION

- A. Wherever dissimilar metals, except conduit and conduit fittings, come into contact, the Contractor shall isolate these metals as required with neoprene washers, nine (9) mil polyethylene tape, or gaskets.

- END OF SECTION -

## SECTION 16111 - CONDUIT

### PART 1 -- GENERAL

#### 1.01 THE REQUIREMENT

- A. The Contractor shall furnish and install conduits and conduit fittings to complete the installation of all electrically operated equipment as specified herein, indicated on the Drawings, and as required.
- B. Requirements for conduit clamps, support systems, and anchoring are not included in this Section. Reference Section 16190, Electrical Supporting Devices, for these requirements.
- C. Reference Section 16000 - Basic Electrical Requirements.

#### 1.02 CODES AND STANDARDS

- A. Conduits and conduit fittings shall be designed, manufactured, and/or listed to the following standards as applicable:
  - 1. American National Standards Institute (ANSI)
    - a. ANSI B1.20.1 – Pipe Threads, General Purpose
    - b. ANSI C80.1 – Electrical Rigid Steel Conduit
    - c. ANSI C80.3 – Steel Electrical Metallic Tubing
    - d. ANSI C80.5 – Electrical Rigid Aluminum Conduit
    - e. ANSI FB 1 – Fittings, Cast Metal Boxes, and Conduit Bodies for Conduit, Electrical Metallic Tubing, and Cable
  - 2. Underwriters Laboratories (UL)
    - a. UL 1 – Standard for Flexible Metal Conduit
    - b. UL 6 - Electrical Rigid Metal Conduit-Steel
    - c. UL 6A – Electrical Rigid Metal Conduit-Aluminum, Red Brass, and Stainless Steel
    - d. UL 360 – Standard for Liquid-tight Flexible Metal Conduit
    - e. UL 467 – Grounding and Bonding Equipment
    - f. UL 514B – Conduit, Tubing, and Cable Fittings
    - g. UL 651 – Standard for Schedule 40 and 80 Conduit and Fittings
    - h. UL 797 – Electrical Metallic Tubing-Steel
    - i. UL 1203 - Standard for Explosion-proof and Dust-ignition-proof Electrical Equipment for use in Hazardous (Classified) Locations
    - j. UL 1479 – Standard for Fire Tests of Penetration Fire Stops
    - k. UL 1660 – Liquid-tight Flexible Nonmetallic Conduit
  - 3. National Electrical Manufacturer's Association (NEMA)

- a. NEMA RN 1 – PVC Externally Coated Galvanized Rigid Steel Conduit
- b. NEMA TC-2 – Electrical PVC Conduit
- c. NEMA TC-3 – PVC Fittings for Use with Rigid PVC Conduit and Tubing

4. Others

- a. ACI-318 – Building Code Requirements for Structural Concrete

1.03 SUBMITTALS

- A. In accordance with the procedures and requirements set forth in the General Conditions and Section 01300 – Submittals, the Contractor shall obtain from the equipment manufacturer and submit the following:

- 1. Shop Drawings

- B. Each submittal shall be identified by the applicable specification section.

1.04 SHOP DRAWINGS

- A. Each submittal shall be complete in all respects, incorporating all information and data listed herein and all additional information required for evaluation of the proposed equipment's compliance with the Contract Documents.

- B. Partial, incomplete, or illegible submittals will be returned to the Contractor without review for resubmittal.

- C. Shop drawings shall include but not be limited to:

- 1. Product data sheets for conduits and fittings.
- 2. Conduit identification methods and materials.
- 3. Evidence of training for all personnel that will install PVC coated rigid metal conduit.

1.05 DEFINITIONS

- A. Conduits are categorized by the circuit type of the wiring to be installed inside. Conduits are defined as follows:

- 1. Power Conduits – Conduits that carry AC or DC power wiring from a source to a load. Conduits that carry lighting and receptacle wiring.

2. Control Conduits – Conduits that carry AC or DC discrete control wiring between devices and/or equipment. Conduits that carry fiber optic cables between devices and/or equipment.
  3. Instrumentation Conduits – Conduits that carry AC or DC analog signal wiring between devices and/or equipment.
- B. Where conduit tags are used on the drawings, conduit categories are indicated on the Drawings by the leading letter of the conduit tag. Conduit tag leading letters are defined as follows:
1. P – Power Conduit
  2. C – Control Conduit
  3. I – Instrumentation Conduit

## PART 2 – PRODUCTS

### 2.01 GENERAL

- A. Conduit and conduit fitting products are specified in the text that follows this article. Reference Part 3 herein for the application, uses and installation requirements of these conduits and conduit fittings.
- B. All metallic conduit fittings shall be UL 514B and UL 467 Listed, and constructed in accordance with ANSI FB 1. All metallic conduit fittings for use in Class I Division I hazardous areas shall be UL 1203 Listed. All non-metallic fittings shall be UL 651 Listed and constructed in accordance with NEMA TC-3.
- C. Flexible conduit couplings for use in Class I Division I hazardous areas shall have threaded stainless steel end fittings and a flexible braided core. Flexible braid shall be constructed of stainless steel where available in the conduit trade size required for the application. Where stainless steel braid is not available, the braid shall be provided with a PVC coating. No other braid types or materials are acceptable.
- D. Where threading is specified herein for conduit fitting connections, the fittings shall be manufactured to accept conduit that is threaded to ANSI B1.20.1 requirements.
- E. Conduit expansion fittings for all conduit materials of construction shall be capable of 4 inches of movement along the axis of the conduit for trade sizes 2 inches or less. Expansion fittings shall be capable of 8 inches of movement along the axis of the conduit for trade sizes greater than 2 inches.
- F. Conduit deflection fittings for all conduit materials of construction shall be provided with a flexible neoprene outer jacket that permits up to  $\frac{3}{4}$  inch of expansion/contraction along the

axis of the conduit as well as up to  $\frac{3}{4}$  inch of parallel misalignment between the conduit axes. Outer jacket shall be secured to the conduit hubs by stainless steel clamps.

- G. Conduit seals shall either be Listed and labeled for 40% fill, or conduit reducing fittings and a trade size larger conduit seal shall be provided to achieve 25% or less fill within the seal. Percentage fill calculation shall be based on the conductors to be installed. Conduit seals shall be provided with breathers and/or drains where required by the NEC.
- H. Conduit insulating bushings shall be constructed of plastic and shall have internal threading.
- I. Additional conduit and conduit fitting requirements are specified in the articles that follow, based on the specific conduit material of construction to be used.

## 2.02 RIGID GALVANIZED STEEL (RGS) CONDUIT AND ASSOCIATED FITTINGS

### A. Conduit

- 1. Conduit shall be hot dip galvanized on the inside and outside, and made of heavy wall high strength ductile steel. Conduit shall be manufactured in accordance with ANSI C80.1, and shall be UL 6 Listed.
- 2. Conduit shall be provided with factory-cut  $\frac{3}{4}$ " per foot tapered threads at each end in accordance with ANSI B1.20.1. Threads shall be cut prior to galvanizing to ensure corrosion protection adequately protects the threads. Conduit shall be provided with a matching coupling on one end and a color-coded thread protector on the other.

### B. Conduit Bodies for use with Rigid Galvanized Steel

- 1. Conduit bodies shall be constructed of an electro-galvanized malleable iron alloy which is coated with an acrylic paint finish. Conduit bodies shall have integral threaded conduit hubs.
- 2. Conduit bodies for Class I Division I hazardous areas shall be provided with integrally threaded covers constructed of an electro-galvanized malleable iron alloy which is coated with an acrylic paint finish.
- 3. Conduit bodies for all other areas shall be provided with covers that are affixed in place by stainless steel screws which thread directly into the conduit body. Covers that utilize wedge nuts or any other method of attachment to the conduit body are not acceptable. Covers shall be constructed of an electro-galvanized malleable iron alloy which is coated with an acrylic paint finish. Covers shall be provided with matching gasket.

C. Conduit Couplings, Nipples, and Unions for use with Rigid Galvanized Steel

1. Couplings and nipples shall be threaded and shall be constructed of hot dipped galvanized steel. Split-type couplings that use compression to connect conduits are not acceptable.
2. Unions shall be threaded, rain-tight, and constructed of an electro-galvanized malleable iron alloy which is coated with an acrylic paint finish.

D. Conduit Expansion and Deflection Fittings for use with Rigid Galvanized Steel

1. Conduit expansion fittings and conduit deflection fittings shall be constructed of an electro-galvanized malleable iron alloy which is coated with an acrylic paint finish. Expansion and deflection fittings shall have threaded conduit connections.
2. Expansion fittings shall have an integral bonding jumper and deflection fittings shall have an external bonding jumper.

E. Conduit Seals for use with Rigid Galvanized Steel

1. Conduit seals shall be constructed of an electro-galvanized malleable iron alloy which is coated with an acrylic paint finish. Conduit seals shall have threaded conduit connections.

F. Conduit Termination Fittings for use with Rigid Galvanized Steel

1. Conduit hubs shall be constructed of stainless steel and shall have threaded connections to the conduit and enclosure. Hubs shall have a plastic insulated throat and shall be watertight when assembled to an enclosure.
2. Conduit locknuts shall be constructed of zinc plated steel. Locknuts shall have internal threading. Locknuts with integral gasket or seal are not acceptable. Locknuts shall have integral bonding screw where required for proper bonding.
3. Conduit bonding bushings shall be constructed of zinc plated malleable iron. Bonding bushings shall have a threaded conduit connection. Bonding bushing shall be provided with properly sized set screw for connecting bonding conductor and an integral plastic insulator rated for 150 degrees C located in the throat.

2.03 RIGID NONMETALLIC CONDUIT AND ASSOCIATED FITTINGS

A. Conduit

1. Conduit shall be Schedule 40 or 80 (dependent on application) polyvinyl chloride (PVC) construction, manufactured in accordance with NEMA TC-2, UL 651 Listed, and suitable for conductors with 90 degree C insulation.



B. Conduit Bodies for use with Rigid Nonmetallic Conduit

1. Conduit bodies shall be constructed of PVC. Conduit hubs shall be integral to the conduit body and shall be smooth inside to accept a glued conduit connection.
2. Conduit body shall be provided with cover that is affixed in place by stainless steel screws which thread directly into the conduit body. Covers that utilize wedge nuts or any other method of attachment to the conduit body are not acceptable. Covers shall be provided with matching gasket.

C. Conduit Couplings and Unions for use with Rigid Nonmetallic Conduit

1. Conduit couplings and unions shall be constructed of PVC and shall be smooth inside to accept a glued conduit connection.

D. Conduit Expansion and Deflection Fittings for use with Rigid Nonmetallic Conduit

1. Conduit expansion fittings and conduit deflection fittings shall be constructed of PVC and shall be smooth inside to accept a glued conduit connection.

E. Conduit Termination Fittings for use with Rigid Nonmetallic Conduit

1. Conduit hubs shall be constructed of PVC and shall be smooth inside to accept a glued conduit connection. Hubs shall have external threads and an accompanying PVC locknut, and shall be watertight when assembled to an enclosure.
2. Conduit locknuts shall be constructed of zinc plated steel. Locknuts shall have internal threading. Locknuts constructed of PVC and locknuts with integral gasket or seal are not acceptable.
3. Conduit end bells shall be constructed of PVC and shall be smooth inside to accept a glued conduit connection. End bell shall have a smooth inner surface that curves outward towards the edge of the fitting.

2.04 PVC COATED RIGID GALVANIZED STEEL CONDUIT AND ASSOCIATED FITTINGS

A. General

1. Where an external coating of polyvinyl chloride (PVC) is specified for conduit and fittings, the coating shall be 40 mil (minimum) thickness. Where an internal coating of urethane is specified for conduit and fittings, the coating shall be 2 mil (minimum) thickness.

2. All conduit fittings shall have a sealing sleeve constructed of PVC which covers all connections to conduit. Sleeves shall be appropriately sized so that no conduit threads will be exposed after assembly.

B. Conduit

1. Conduit shall be hot dip galvanized on the inside and outside, and made of heavy wall high strength ductile steel. Conduit shall be manufactured in accordance with ANSI C80.1, and shall be UL 6 Listed.
2. Conduit shall be provided with factory-cut  $\frac{3}{4}$ " per foot tapered threads at each end in accordance with ANSI B1.20.1. Threads shall be cut prior to galvanizing to ensure corrosion protection adequately protects the threads. Conduit shall be provided with a matching coupling on one end and a color-coded thread protector on the other.
3. Conduit shall be coated on the exterior with a PVC jacket and coated on the interior with a layer of urethane. Conduit shall be manufactured in accordance with NEMA RN-1.

C. Conduit Bodies for use with PVC Coated Rigid Galvanized Steel Conduit

1. Conduit bodies shall be constructed of an electro-galvanized malleable iron alloy which is coated on the exterior with a PVC jacket and coated on the interior with a layer of urethane. Conduit bodies shall have integral threaded conduit hubs.
2. Conduit bodies for Class I Division I hazardous areas shall be provided with integrally threaded covers constructed of an electro-galvanized malleable iron alloy which is coated on the exterior with a PVC jacket and coated on the interior with a layer of urethane.
3. Conduit bodies for all other areas shall be constructed of an electro-galvanized malleable iron alloy which is coated on the exterior with a PVC jacket and coated on the interior with a layer of urethane. Covers shall be affixed in place by stainless steel screws which thread directly into the conduit body and have a plastic encapsulated head. Covers that utilize wedge nuts or any other method of attachment to the conduit body are not acceptable. Covers shall be provided with matching gasket.

D. Conduit Couplings, Nipples, and Unions for use with PVC Coated Rigid Galvanized Steel Conduit

1. Couplings and nipples shall be threaded and shall be constructed of hot dipped galvanized steel which is coated on the exterior with a PVC jacket and coated on the interior with a layer of urethane. Split-type couplings that use compression to connect conduits are not acceptable.

2. Unions shall be threaded, rain-tight, and constructed of an electro-galvanized malleable iron alloy which is coated on the exterior with a PVC jacket and coated on the interior with a layer of urethane.
- E. Conduit Expansion and Deflection Fittings for use with PVC Coated Rigid Galvanized Steel Conduit
1. Conduit expansion fittings and conduit deflection fittings shall be constructed of an electro-galvanized malleable iron alloy which is coated on the exterior with a PVC jacket and coated on the interior with a layer of urethane. Expansion and deflection fittings shall have threaded conduit connections.
  2. Expansion fittings shall have an integral bonding jumper and deflection fittings shall have an external bonding jumper.
- F. Conduit Seals for use with PVC Coated Rigid Galvanized Steel Conduit
1. Conduit seals shall be constructed of an electro-galvanized malleable iron alloy which is coated on the exterior with a PVC jacket and coated on the interior with a layer of urethane. Conduit seals shall have threaded conduit connections.
- G. Conduit Termination Fittings for use with PVC Coated Rigid Galvanized Steel Conduit
1. Conduit hubs shall be constructed of an electro-galvanized malleable iron alloy which is coated on the exterior with a PVC jacket and coated on the interior with a layer of urethane. Hubs shall have threaded connections to the conduit and enclosure. Hubs shall have a plastic insulated throat and shall be watertight when assembled to an enclosure.
  2. Conduit bonding bushings shall be constructed of zinc plated malleable iron which is coated on the exterior with a PVC jacket and coated on the interior with a layer of urethane. Bonding bushings shall have a threaded conduit connection. Bonding bushing shall be provided with properly sized set screw for connecting bonding conductor and an integral plastic insulator rated for 150 degrees C located in the throat.

## 2.05 RIGID ALUMINUM CONDUIT AND ASSOCIATED FITTINGS

### A. Conduit

1. Conduit shall be made of heavy wall high strength 6063 alloy aluminum with temper designation T1. Conduit shall be manufactured in accordance with ANSI C80.5, and shall be UL 6A Listed.

2. Conduit shall be provided with factory-cut  $\frac{3}{4}$ " per foot tapered threads at each end in accordance with ANSI B1.20.1. Threads shall be cut prior to galvanizing to ensure corrosion protection adequately protects the threads. Conduit shall be provided with a matching coupling on one end and a color-coded thread protector on the other.

B. Conduit Bodies for use with Rigid Aluminum Conduit

1. Conduit bodies shall be constructed of copper-free aluminum which is coated with an aluminum enamel finish. Conduit bodies shall have integral threaded conduit hubs.
2. Conduit bodies for Class I Division I hazardous areas shall be provided with integrally threaded covers constructed of copper-free aluminum which is coated with an aluminum enamel finish.
3. Conduit bodies for all other areas shall be provided with stamped copper-free aluminum covers that are affixed in place by stainless steel screws which thread directly into the conduit body. Covers that utilize wedge nuts or any other method of attachment to the conduit body are not acceptable. Covers shall be provided with matching gasket.

C. Conduit Couplings, Nipples, and Unions for use with Rigid Aluminum Conduit

1. Couplings and nipples shall be threaded and shall be constructed of heavy wall high strength 6063 alloy aluminum with temper designation T1. Split-type couplings that use compression to connect conduits are not acceptable.
2. Unions shall be threaded, rain-tight, and constructed of copper-free aluminum which is coated with an aluminum enamel finish.

D. Conduit Expansion and Deflection Fittings for use with Rigid Aluminum Conduit

1. Conduit expansion fittings and conduit deflection fittings shall be constructed of copper-free aluminum which is coated with an aluminum enamel finish. Expansion and deflection fittings shall have threaded conduit connections.
2. Expansion fittings shall have an integral bonding jumper and deflection fittings shall have an external bonding jumper.

E. Conduit Seals for use with Rigid Aluminum Conduit

1. Conduit seals shall be constructed of copper-free aluminum which is coated with an aluminum enamel finish. Conduit seals shall have threaded conduit connections.

F. Conduit Termination Fittings for use with Rigid Aluminum Conduit

1. Conduit hubs shall be constructed of copper-free aluminum and shall have threaded connections to the conduit and enclosure. Hubs shall have a plastic insulated throat and shall be watertight when assembled to an enclosure.
2. Conduit locknuts shall be constructed of copper-free aluminum. Locknuts shall have internal threading. Locknuts with integral gasket or seal are not acceptable. Locknuts shall have integral bonding screw where required for proper bonding.
3. Conduit bonding bushings shall be constructed of copper-free aluminum. Bonding bushings shall have a threaded conduit connection. Bonding bushing shall be provided with properly sized set screw for connecting bonding conductor and an integral plastic insulator rated for 150 degrees C located in the throat.

2.06 LIQUID TIGHT FLEXIBLE METAL CONDUIT (LFMC) AND ASSOCIATED FITTINGS

A. Conduit

1. Conduit shall be manufactured using a single strip of hot dip galvanized high strength steel alloy, helically formed into a continuously interlocked flexible metal conduit. Trade size 1-1/4" and smaller conduits shall be provided with an integrally woven copper bonding strip.
2. Conduit shall be covered with an outside PVC jacket that is UV resistant, moisture-proof, and oil-proof. Conduit shall be UL 360 Listed.

B. Conduit Termination Fittings for use with LFMC

1. Conduit termination fittings shall be constructed of either 304 stainless steel or an electro-galvanized malleable iron alloy which is coated on the exterior with a 40 mil (minimum) PVC jacket and coated on the interior with a 2 mil (minimum) layer of urethane. PVC coated fittings shall have a sealing sleeve constructed of PVC which covers the connection to conduit.
2. Termination fittings shall have a threaded end with matching locknut and sealing ring for termination to equipment, and shall have an integral external bonding lug where required for proper bonding. Termination fittings shall have a plastic insulated throat and shall be watertight when assembled to the conduit and equipment.

2.07 LIQUID TIGHT FLEXIBLE NONMETALLIC CONDUIT (LFNC) AND ASSOCIATED FITTINGS

A. Conduit

1. Conduit shall be constructed of rigid polyvinyl chloride (PVC), fabricated to provide flexibility. Conduit shall be covered with an outside PVC jacket that is UV resistant, moisture-proof, and oil-proof. Conduit shall be UL 1660 Listed.

B. Conduit Termination Fittings for use with LFNC

1. Conduit termination fittings shall be constructed PVC and shall have a threaded end with matching locknut and sealing ring for termination to equipment. Termination fittings shall be watertight when assembled to the conduit and equipment.

## 2.08 FLEXIBLE METAL CONDUIT (FMC) AND ASSOCIATED FITTINGS

A. Conduit

1. Conduit shall be manufactured using a single strip of hot dip galvanized high strength steel alloy, helically formed into a continuously interlocked flexible metal conduit. Conduit shall be UL 1 Listed.

B. Conduit Termination Fittings for use with FMC

1. Conduit termination fittings shall be constructed of an electro-galvanized malleable iron alloy. Fittings shall have a threaded end with matching locknut for termination to equipment, and a compression-style connection to the associated conduit.

## 2.09 ELECTRICAL METALLIC TUBING (EMT) AND ASSOCIATED FITTINGS

A. Conduit

1. Conduit shall be hot dipped galvanized on the inside and outside, and made of cold-rolled steel tubing. Conduit shall be manufactured in accordance with C80.3 and shall be UL 797 listed.

B. Conduit Bodies for use with EMT

1. Conduit bodies shall be constructed of an electro-galvanized malleable iron alloy which is coated with an acrylic paint finish. Conduit bodies shall have integral threaded conduit hubs.
2. Conduit bodies shall be provided with galvanized sheet steel covers that are affixed in place by stainless steel screws which thread directly into the conduit body. Covers that utilize wedge nuts or any other method of attachment to the conduit body are not acceptable. Covers shall be provided with matching gasket.

C. Conduit Couplings and Nipples for use with EMT

1. Couplings and nipples shall have threaded compression connectors with associated gland and shall be constructed of electro-galvanized steel. Fittings utilizing a set screw or indenter tool to secure the associated conduit to the fitting are not acceptable. Couplings and nipples shall be rain-tight and have a plastic insulated throat.

D. Conduit Expansion and Deflection Fittings for use with EMT

1. Conduit expansion fittings and conduit deflection fittings shall be constructed of an electro-galvanized malleable iron alloy which is coated with an acrylic paint finish. Expansion and deflection fittings shall have threaded conduit connections.
2. Expansion fittings shall have an integral bonding jumper and deflection fittings shall have an external bonding jumper.

E. Conduit Termination Fittings for use with EMT

1. Conduit termination fittings shall be constructed of electro-galvanized steel and have a plastic insulated throat. Termination fittings shall have a threaded compression connector with associated gland on one end and external threads on the other end. Termination fittings utilizing a set screw or indenter tool to secure the associated conduit to the fitting are not acceptable.
2. Conduit locknuts shall be constructed of zinc plated steel. Locknuts shall have internal threading. Locknuts shall have integral bonding screw where required for proper bonding.

2.10 CONDUIT BENDS

- A. Rigid conduit bends, both factory fabricated and field fabricated, shall meet the same requirements listed in the articles above for the respective conduit type and material of construction.
- B. Conduit bend radii for standard radius bends shall be no less than as follows:

TRADE SIZE	¾"	1"	1 ¼"	1 ½"	2"	2 ½"	3"	3 ½"	4"	5"	6"
MIN. RADIUS	4 ½"	5 ¾"	7 ¼"	8 ¼"	9 ½"	10 ½"	13"	15"	16"	24"	30"

- C. Conduit bend radii for long radius bends shall be no less than as follows:

TRADE SIZE	¾"	1"	1 ¼"	1 ½"	2"	2 ½"	3"	3 ½"	4"	5"	6"
MIN. RADIUS	N/A	12"	18"	24"	30"	30"	36"	36"	48"	48"	60"

2.11 MISCELLANEOUS

- A. Conduit Periphery Sealing

1. The sealing of the exterior surface of conduits to prevent water and/or air from passing around the conduit periphery from one space to another (where required) shall be through the use of one of the following:
  - a. A conduit sleeve and pressure bushing sealing system. Acceptable products are FSK by OZ-GEDNEY, Link-Seal by Crouse-Hinds, or Engineer approved equal.
  - b. A conduit sleeve that is two trade sizes larger than the conduit being sealed, with 2-hour fire rated UL 1479 Listed caulk filling the entire void between the conduit and sleeve. This method is only suitable for penetrations in non-fire rated walls and floors between spaces within buildings. This method shall not be used for the sealing of conduits leaving a building and/or structure.
2. Conduit penetrations through fire-rated walls and floors shall be made with an approved UL 1479 Listed product specifically intended for the trade size of the conduit.

B. Primer and Cement

1. Nonmetallic conduit shall be cleaned with primer and connected to fittings with the manufacturer's recommended cement that is labeled Low VOC.

C. Galvanizing Compounds

1. Galvanizing compounds for field application shall be the cold-applied type, containing no less than 93% pure zinc.

D. Conduit Interior Sealing

1. The sealing of the inside of conduits against water ingress shall be achieved through the use of one of the following:
  - a. Two-part expanding polyurethane foam sealing compound, dispensed from a single tube which mixes the two parts as it is injected into the conduit. Expanding foam shall be compatible with the conduit material of construction as well as the outer jacket of the cables in the conduit. Acceptable products are Q-Pak 2000 by Chemque, FST by American Polywater Corporation, or Hydra-seal S-60 by Duraline.
  - b. Inflatable bag that provides seal around cables and around inside diameter of conduit. Provide appropriate quantity of additional fittings for applications with three or more cables in the conduit to be sealed. Acceptable products are Rayflate by Raychem, or Engineer approved equal. This sealing method is only applicable to conduits trade size 2" and larger.
  - c. Neoprene sealing ring provided with the required quantity and diameter of holes to accommodate the cables in each conduit. Sealing ring shall be



compressed by two stainless steel pressure plates. Acceptable products are type CSB by OZ-GEDNEY, or Engineer approved equal. This sealing method is only applicable to metallic conduits containing 4 cables or less.

2. The use of aerosol-based expanding foam sealants or any other method of sealing against water ingress not listed above is not acceptable.

E. Pull Rope

1. Pull ropes for empty and spare conduits shall be woven polyester, ½" wide, with a minimum tensile strength of 1250 lbs.
2. Pull ropes for the Contractors use in installing conductors shall be the size and strength required for the pull, and shall be made of a non-metallic material.

### PART 3 – EXECUTION

#### 3.01 GENERAL

- A. Minimum trade size for all rigid conduits shall be ¾ inch in exposed applications and 1 inch in embedded applications. Conduits installed within ductbanks shall be allowed to be increased in size to trade size 2 inch, at the Contractor's option, to accommodate the saddle size of the ductbank spacers. However, no combining of circuits shall be allowed in the larger conduits.
- B. Minimum trade size for flexible conduits (where specifically allowed herein) shall be ½ inch in all applications.
- C. Conduit routing and/or homeruns within structures is not shown on the Drawings. Conduits shall be installed concealed wherever practical and within the limitations specified herein. All other conduits not capable of being installed concealed shall be installed exposed.
- D. Empty and/or spare conduits shall be provided with pull ropes which have no less than 12 inches of slack at each end.
- E. Nonmetallic conduits for installations requiring less than a factory length of conduit shall be field cut to the required length. The cut shall be made square, cleaned of debris, and primer shall be applied to ready each joint for fusing. Conduits shall then be fused together with the conduit manufacturer's approved cement compound.
- F. Metallic conduits for installations requiring less than a factory length of conduit shall be field cut to the required length. The cut shall be made square, be cleaned of all debris and be deburred, then threaded. Conduit threading performed in the field shall be ¾ inch per foot tapered threads in accordance with ANSI B1.20.1.

- G. Conduits shall be protected from moisture, corrosion, and physical damage during construction. Install dust-tight and water-tight conduit fittings on the ends of all conduits immediately after installation and do not remove until conductors are installed.
- H. Conduits shall be installed to provide no less than 12 inches clearance from pipes that have the potential to impart heat upon the conduit. Such pipes include, but are not limited to, hot water pipes, steam pipes, exhaust pipes, and blower air pipes. Clearance shall be maintained whether conduit is installed in parallel or in crossing of pipes.
- I. Where non-metallic instrumentation conduits are installed exposed, the following clearances to other conduit types shall be maintained:
  - 1. Instrumentation conduits installed parallel to conduits with conductors energized at 480V or above shall be 18 inches.
  - 2. Instrumentation conduits installed parallel to conduits with conductors energized at 240V and below shall be 12 inches.
  - 3. Instrumentation conduits installed at right angles to conductors energized at 480V and below shall be 6 inches.
  - 4. Instrumentation conduits installed at right angles to conductors energized at voltages above 480V shall be 12 inches.
- J. Where conduit fittings installed at termination points do not include an integral insulated bushing, an insulated bushing shall be installed.
- K. Conduits which serve multi-section equipment shall be terminated in the section where wiring terminations will be made.
- L. Conduits shall not penetrate the floors or walls inside liquid containment areas without specific written authorization from the Engineer. Liquid containment areas are indicated on the Drawings.
- M. In no case shall conduit be supported or fastened to another pipe or installed to prevent the removal of other pipe for repairs. Spring steel fasteners may only be used to affix conduits containing lighting branch circuits within EMT conduits to structural steel members.
- N. All field fabricated threads for EMT, rigid galvanized, or PVC-coated rigid galvanized steel conduit shall be thoroughly coated with two coats of galvanizing compound, allowing at least two minutes to elapse between coats for proper drying.
- O. The appropriate specialized tools shall be used for the installation of PVC coated conduit and conduit fittings. No damage to the PVC coating shall occur during installation.

Conduit and conduit fittings with damaged PVC coating shall be replaced at the Contractor's cost. The use of PVC coating touch-up compounds is not permitted.

- P. Conduits which emerge from within or below concrete encasement shall be PVC coated rigid galvanized steel in accordance with Standard Detail 1611102 where the conduit is not protected by an equipment enclosure that surrounds the conduit on all sides at the point where it emerges from the encasement.
- Q. Aluminum conduits shall not be installed in direct contact with concrete surfaces. Where aluminum conduits are routed along concrete surfaces, they shall be installed with one-hole electro-galvanized malleable iron alloy straps with matching clamp-backs to space the conduit ¼ inch away from concrete surface. Where aluminum conduit passes through concrete, CMU or brick walls, the penetration shall be made such that the aluminum conduit does not come in contact with concrete, CMU, brick or mortar.

### 3.02 CONCEALED AND EMBEDDED CONDUITS

- A. Conduits are permitted to be installed concealed and/or embedded with the following requirements:
  - 1. Conduits shall not be installed horizontally when concealed within CMU walls, only vertical installation is acceptable.
  - 2. Conduits installed embedded within concrete floors or walls shall be located so as not to affect the designed structural strength of the floor or wall. Embedded conduits shall be installed in accordance with Standard Detail 0331604 and ACI-318.
  - 3. Where conduit bends emerge from concrete embedment, none of the curved portion of the bend shall be visible. Only the straight portion of the bend shall be visible.
  - 4. Where multiple conduits emerge from concrete embedment or from concealment below a concrete floor, ample clear space shall be provided between conduits to allow for the appropriate and required conduit termination fittings to be installed.
  - 5. Conduits installed embedded within concrete encasement of any kind shall be installed such that conduit couplings for parallel conduits are staggered so that they are not side by side.
- B. Conduits are NOT permitted to be installed concealed and/or embedded for the following situations:
  - 1. Conduits shall not be installed embedded within any water-bearing floors or walls. Conduits shall not be installed embedded within any liquid containment area floors or walls.

2. Conduits shall not be installed concealed within CMU walls or gypsum walls that are adjacent to Class I and II hazardous areas (Division I and Division II).
3. Conduits shall not be installed concealed within CMU walls or gypsum walls that are adjacent to indoor Type 1 or Type 2 chemical storage/transfer areas.

### 3.03 CONDUIT USES AND APPLICATIONS

#### A. Rigid Conduit

1. Rigid conduit for non-hazardous areas shall be furnished and installed in the materials of construction as follows:

<b>RIGID CONDUIT FOR NON-HAZARDOUS AREAS</b>		
<b>INSTALLATION AREA DESIGNATION/ SCENARIO</b>	<b>CONDUIT CATEGORY BY WIRING/CIRCUIT TYPE</b>	
	<b>Power and Control</b>	<b>Instrumentation</b>
Exposed in indoor wet process areas	Rigid aluminum conduit	PVC coated rigid galvanized steel conduit
Exposed in indoor dry process areas	Rigid aluminum conduit	PVC coated rigid galvanized steel conduit
Exposed in indoor dry non-process areas	Rigid galvanized steel conduit	Same as Power and Control
Exposed in Type 1 chemical storage/transfer areas	Schedule 80 rigid non-metallic PVC conduit	Same as Power and Control
Exposed in Type 2 chemical storage/transfer areas	Rigid aluminum conduit	Same as Power and Control
Exposed in outdoor areas	Rigid aluminum conduit	PVC coated rigid galvanized steel
Exposed within pre-fabricated electrical equipment center buildings	Electrical Metallic Tubing	Same as Power and Control
Concealed within underground direct-bury or concrete-encased ductbanks	Schedule 40 rigid non-metallic PVC conduit	PVC coated rigid galvanized steel conduit
Concealed within non-elevated (i.e. "slab-on-grade" construction) concrete slabs	Schedule 40 rigid non-metallic PVC conduit	Rigid galvanized steel conduit
Concealed within elevated concrete slabs	Rigid galvanized steel conduit	Same as Power and Control
Concealed below concrete slabs (within earth or fill material)	Schedule 40 rigid non-metallic PVC conduit	PVC coated rigid galvanized
Concealed within concrete walls	Schedule 40 rigid non-metallic PVC conduit	Rigid galvanized steel conduit

<b>RIGID CONDUIT FOR NON-HAZARDOUS AREAS</b>		
<b>INSTALLATION AREA DESIGNATION/ SCENARIO</b>	<b>CONDUIT CATEGORY BY WIRING/CIRCUIT TYPE</b>	
	<b>Power and Control</b>	<b>Instrumentation</b>
Concealed within CMU walls	Schedule 40 rigid non-metallic PVC conduit or Electrical Metallic Tubing	Rigid galvanized steel conduit or Electrical Metallic Tubing
Concealed above suspended ceilings	Electrical Metallic Tubing	Same as Power and Control
Concealed within interior walls constructed of metal studs and gypsum wall board	Electrical Metallic Tubing	Same as Power and Control
Emerging from concealment within or below a concrete floor and transitioning to exposed conduit (Reference Detail 1611102)	PVC coated rigid galvanized steel conduit	Same as Power and Control

2. Rigid conduit for hazardous areas shall be furnished and installed in the materials of construction as follows:

<b>RIGID CONDUIT FOR HAZARDOUS AREAS</b>		
<b>INSTALLATION AREA HAZARD/SCENARIO</b>	<b>CONDUIT CATEGORY BY WIRING/CIRCUIT TYPE</b>	
	<b>Power and Control</b>	<b>Instrumentation</b>
Exposed in indoor dry Class I and II areas (Division I and Division II)	Rigid aluminum conduit	Rigid galvanized steel conduit
Exposed in indoor wet Class I and II areas (Division I and Division II)	Rigid aluminum conduit	PVC coated rigid galvanized steel conduit
Exposed in outdoor Class I and II areas (Division I and Division II)	Rigid aluminum conduit	PVC coated rigid galvanized steel conduit
Concealed within concrete slabs in Class I and II areas (Division I and Division II)	Rigid galvanized steel conduit	Same as Power and Control
Concealed below concrete slabs (within earth or fill material) in Class I and II areas (Division I and Division II)	Rigid galvanized steel conduit	Same as Power and Control
Concealed within concrete walls in Class I and II areas (Division I and Division II)	Rigid galvanized steel conduit	Same as Power and Control
Concealed below concrete slabs encased in at least two inches of concrete and buried 24 inches below top of slab in Class I Division I areas	Schedule 40 rigid non-metallic PVC conduit	Rigid galvanized steel conduit

<b>RIGID CONDUIT FOR HAZARDOUS AREAS</b>		
<b>INSTALLATION AREA HAZARD/SCENARIO</b>	<b>CONDUIT CATEGORY BY WIRING/CIRCUIT TYPE</b>	
	<b>Power and Control</b>	<b>Instrumentation</b>
Concealed above suspended ceilings in Class I and II areas (Division I and Division II)	Rigid aluminum conduit	Rigid galvanized steel conduit

3. The tables for the materials of construction for conduits in non-hazardous and hazardous areas are intended to exhaustively cover all possible scenarios and installation areas under this Contract. However, if a scenario or installation area is found that is not explicitly governed by these tables, it shall be assumed for bid purposes that the conduit material of construction is to be rigid galvanized steel. This discrepancy shall be brought to the attention of the Engineer (in writing) immediately for resolution.

**B. Conduit Bends**

1. All conduit bends shall be the same material of construction as the rigid conduit listed in the tables above, with the following exceptions:
  - a. All 90 degree bends or combinations of adjacent bends that form a 90 degree bend where concealed within concrete or below a concrete slab shall be PVC coated rigid galvanized steel.
2. Field fabricated bends of metallic conduit shall be made with a bending machine and shall have no kinks. Field fabricated standard radius and long radius bends shall have minimum bending radii in accordance with the associated tables in Part 2 herein.
3. Field bending of non-metallic conduits is not acceptable, factory fabricated bends shall be used.
4. Long radius bends shall be furnished and installed for the following specific applications, all other bends shall be standard radius:
  - a. All conduits containing medium voltage cable.
  - b. All conduits containing fiber optic cable.
  - c. All conduits containing shielded VFD cable.
  - d. Where specifically indicated on the Drawings.

**C. Flexible Conduit**

1. Flexible conduit shall only be installed for the limited applications specified herein. Flexible conduit shall not be installed in any other application without written authorization from the Engineer. Acceptable applications are as follows:

- a. Connections to motors and engine-generator sets (and similar vibrating equipment)
  - b. Connections to solenoid valves and limit switches
  - c. Connections to lighting fixtures installed in suspended ceilings
  - d. Connections to lighting transformers
  - e. Connections to pre-fabricated equipment skids
  - f. Connections to HVAC equipment
  - g. Connections to instrument transmitters and elements
  - h. Where specifically indicated in the Standard Details
2. Flexible conduit length shall be limited to three (3) feet, maximum. Flexible conduit shall not be installed buried or embedded within any material.
  3. Flexible conduit for non-hazardous areas shall be furnished and installed in the materials of construction as follows:

<b>FLEXIBLE CONDUIT FOR NON-HAZARDOUS AREAS</b>		
<b>INSTALLATION AREA DESIGNATION/SCENARIO</b>	<b>CONDUIT CATEGORY BY WIRING/CIRCUIT TYPE</b>	
	<b>Power and Control</b>	<b>Instrumentation</b>
Exposed in indoor wet process areas	Liquid-tight flexible metal conduit	Same as Power and Control
Exposed in indoor dry process areas	Liquid-tight flexible metal conduit	Same as Power and Control
Exposed in indoor dry non-process areas	Flexible metal conduit	Same as Power and Control
Exposed in indoor Type 1 chemical storage/transfer areas	Liquid-tight flexible non-metallic conduit	Same as Power and Control
Exposed in indoor Type 2 chemical storage/transfer areas	Liquid-tight flexible non-metallic conduit	Same as Power and Control
Exposed in outdoor areas	Liquid-tight flexible metal conduit	Same as Power and Control
Concealed above suspended ceilings (all indoor areas)	Flexible metal conduit	Same as Power and Control

4. For Class I Division I hazardous areas, the NEC does not permit the installation of flexible conduit. In lieu of flexible conduit in these areas, flexible conduit couplings shall be installed as specified in Part 2 herein. Flexible conduit for all other hazardous areas shall be furnished and installed in the materials of construction as follows:

<b>FLEXIBLE CONDUIT FOR HAZARDOUS AREAS</b>		
<b>INSTALLATION AREA HAZARD/SCENARIO</b>	<b>CONDUIT CATEGORY BY WIRING/CIRCUIT TYPE</b>	
	<b>Power and Control</b>	<b>Instrumentation</b>
Exposed in Class I Division II areas	Liquid-tight flexible metal conduit	Same as Power and Control
Exposed in Class II (Division I and Division II) areas	Liquid-tight flexible metal conduit	Same as Power and Control
Concealed above suspended ceilings in Class I and II (Division I and Division II) areas	Same material as exposed conduit in same area	Same as Power and Control

### 3.04 CONDUIT FITTING USES AND APPLICATIONS

#### A. General

1. Conduit fittings shall be furnished and installed in the materials of construction as indicated in Part 2, herein. Conduit fitting materials of construction are dependent on the material of construction used for the associated conduit.
2. Conduit fittings shall be provided in the trade size and configuration required to suit the application.

#### B. Conduit Bodies

1. Conduit bodies shall be installed where wire pulling points are desired or required, or where changes in conduit direction or breaking around beams is required.
2. Where conduit bodies larger than trade size 2 inches are intended to be used as a pull-through fitting during wire installation, oversized or elongated conduit bodies shall be used. Oversized or elongated conduit bodies shall not be required if the conduit body is intended to be used as a pull-out point during wire installation.

#### C. Conduit Nipples and Unions

1. Conduits with running threads shall not be used in place of 3-piece couplings (unions) or close nipples. After installation of a conduit fitting of any kind, there shall be no more than ¼ inch of exposed threads visible. Factory fabricated all-thread nipples may be used between adjacent enclosures, however, the same restriction applies regarding the length of exposed threads that are visible.

#### D. Conduit Expansion and Deflection Fittings

1. Conduit expansion fittings shall be installed where required by the NEC and where indicated on the Drawings. Expansion fittings shall also be installed for exposed



straight metallic conduit runs of more than 75 feet, in both indoor and outdoor locations. Expansion fittings for runs of non-metallic conduit shall be installed in accordance with the NEC.

2. Conduit deflection fittings shall be installed where required by the NEC and where conduits are installed (exposed and concealed) across structural expansion joints.

#### E. Conduit Seals

1. Conduit seals shall be installed for conduits installed within or associated with hazardous areas and other areas as required by the NEC. In addition, conduit seals shall also be furnished and installed as follows:
  - a. All conduits entering or leaving enclosed areas which store or distribute chlorine gas.
  - b. All conduits entering or leaving enclosed areas which store or distribute sulfur dioxide gas.

#### F. Conduit Termination Fittings

1. Where conduits terminate at enclosures with a NEMA 4, 4X, or 3R rating and the enclosure does not have integral conduit hubs, an appropriately sized watertight conduit hub shall be installed to maintain the integrity of the enclosure. The use of locknuts with integral gasket in lieu of watertight conduit hubs is not acceptable.
2. Where conduits terminate at enclosures that do not require conduit hubs, a two-locknut system shall be used to secure the conduit to the enclosure. One locknut shall be installed on the outside of the enclosure, and the other inside, drawn tight against the enclosure wall. The locknut on the interior of the enclosure shall be the type with integral bonding lug, or a conduit bonding bushing may be used in place of the locknut.
3. Conduits shall not be installed such that conduit fittings penetrate the top of any enclosure located outdoors, except in cases where specifically required by the serving electric utility. Conduits which serve outdoor equipment or an enclosure from above shall instead be routed into the side of the enclosure at the bottom. The conduit termination fitting shall be provided with a conduit drain to divert moisture from the raceway away from the enclosure.

### 3.05 MISCELLANEOUS

#### A. Conduit Periphery Sealing

1. All conduit penetrations through exterior walls shall be sealed around the periphery using the appropriate products specified in Part 2 herein to prevent air and/or water entry into the structure.

2. All conduit penetrations through interior walls and floors shall be sealed through the use of with conduit sleeves and caulk as specified in Part 2 herein. Alternatively, mortar may be used to seal around the conduit periphery.
3. Conduit penetrations through fire-rated walls as floors shall be made with the appropriate fire rated penetration product.

#### B. Conduit Interior Sealing

1. All conduits (including spares) entering a structure below grade shall be sealed on the interior of the conduit to prevent water ingress. Sealing shall be at an accessible location in the conduit system located within the building structure and shall be via one of the methods specified in Part 2 herein. If conduit sealing cannot be achieved at an accessible location within the building structure, sealing shall be placed in the conduits in the nearest manhole or handhole outside the structure.

### 3.06 CONDUIT IDENTIFICATION

- A. Exposed conduits shall be identified at the source, load, and all intermediate components of the raceway system. Examples of intermediate components include but are not limited to junction boxes, pull boxes, and disconnect switches. Identification shall be by means of an adhesive label with the following requirements:
  1. Labels shall consist of an orange background with black text.
  2. At the source end of the conduit, the text shall indicate the load equipment name. This line shall consist of the word "TO:" and the text in the 'TO' column of the conduit and wire schedule or as called out on the single line and riser diagrams (e.g. TO: Raw Sewage Pump No. 1). At the load end of the conduit, the text shall indicate the source equipment name. This second line shall consist of the word "FROM:" and the text in the 'FROM' column of the conduit and wire schedule or as called out on the single line and riser diagrams (e.g. FROM: MCC-SPS). This requirement applies only to the source and load ends of the conduit, and not anywhere in between.
  3. At intermediate components of the raceway system, the label shall consist of two lines of text. The first shall indicate the source of the conduit, as described above. The second shall indicate the load, as described above.
  4. For conduits trade sizes  $\frac{3}{4}$ " through  $1\frac{1}{2}$ ", the text shall be a minimum 18 point font. For conduits trade size 2" and larger, the text shall be a minimum 24 point font.
  5. Label height shall be  $\frac{3}{4}$ " minimum, and length shall be as required to fit required text. The label shall be installed such that the text is parallel with the axis of the conduit. The label shall be oriented such that the text can be read without the use of any special tools or removal of equipment.

6. Labels shall be installed after each conduit is installed and, if applicable, after painting. Labels shall be printed in the field via the use of a portable label printing system. Handwritten labels are not acceptable.
  7. Labels shall be made of permanent vinyl with adhesive backing. Labels made of any other material are not acceptable.
- B. Conduits that are not exposed but installed beneath free standing equipment enclosures shall be identified by means of a plastic tag with the following requirements:
1. The tag shall be made of white Tyvek material, and have an orange label with black text, as described above, adhered to it. Text for the label shall be as specified in subparagraph A-2 above.
  2. The tag shall be affixed to the conduit by means of a nylon cable tie. The tag shall be of suitable dimensions to achieve a minimum text size of 18 points.
- C. Conduits for lighting and receptacle circuits shall not require identification.
- D. Any problems or conflicts with meeting the requirements above shall immediately be brought to the attention of the Engineer for a decision.

### 3.07 TESTING

- A. All tests shall be performed in accordance with the requirements of the General Conditions and Division 1. The following tests are required:
1. All conduit installed below grade or concrete encased shall be tested to ensure continuity and the absence of obstructions by pulling through each conduit a swab followed by a mandrel 85% of the conduit inside diameter. After testing, all conduits shall be capped after installation of a suitable pulling rope.

### 3.08 TRAINING OF INSTALLATION PERSONNEL

- A. All Contractor personnel that install PVC coated RGS conduit shall be trained by the PVC coated RGS conduit manufacturer. Training shall include proper conduit system assembly techniques, use of tools appropriate for coated conduit systems, and field bending/cutting/threading of coated conduit. Training shall have been completed within the past 24 months prior to the Notice to Proceed on this Contract to be considered valid. Contractor personnel not trained within this timeframe shall not be allowed to install coated conduit, or shall be trained/re-trained as required prior to commencement of conduit installation.

- END OF SECTION -

## SECTION 16123 - LOW VOLTAGE WIRE AND CABLE

### PART 1 -- GENERAL

#### 1.01 THE REQUIREMENT

- A. The Contractor shall furnish, install, connect, test, and place in satisfactory operating condition, all low voltage wire and cable indicated on the Drawings and as specified herein and/or required for proper operation. The work of connecting cables to equipment and devices shall be considered a part of this Section. All appurtenances required for the installation of cable and wire systems shall be furnished and installed by the Contractor.
- B. The scope of this Section does not include internal wiring factory installed by electrical equipment manufacturers.
- C. Reference Section 16000 - Basic Electrical Requirements; Section 16111 - Conduit; and Section 16130 - Boxes.

#### 1.02 SUBMITTALS

- A. In accordance with the procedures and requirements set forth in the General Conditions and Section 01300, Submittals, the Contractor shall obtain from the wire and cable manufacturer and submit the following:
  - 1. Shop Drawings
  - 2. Reports of Field Tests
  - 3. Wiring Identification Methods
- B. Each submittal shall be identified by the applicable specification section.

#### 1.03 SHOP DRAWINGS

- A. Each submittal shall be complete in all respects, incorporating all information and data listed herein and all additional information required for evaluation of the proposed material's compliance with the Contract Documents.
- B. Partial, incomplete, or illegible Submittals will be returned to the Contractor without review for resubmittal.
- C. Shop drawings shall include but not be limited to:
  - 1. Product data sheets.
  - 2. Cable pulling calculations (if required).
  - 3. Wiring identification methods and materials.

#### 1.04 IDENTIFICATION

- A. Each cable shall be identified as specified in Part 3, Execution, of this Specification.

#### 1.05 CABLE PULLING CALCULATIONS

- A. The Contractor shall submit cable pulling calculations. These calculations, to be performed by a currently registered professional engineer in the State of Florida, shall define pulling tension and sidewall loading (sidewall bearing pressure values) for all installations of 600VAC, #1/0 conductors and larger greater than 200 feet in length. Calculations for straight horizontal installations of 600VAC, #1/0 conductors and larger greater than 200 feet are not required.

### PART 2 -- PRODUCTS

#### 2.01 MANUFACTURERS

- A. The wire and cable to be furnished and installed for this project shall be the product of manufacturers who have been in the business of manufacturing wire and cable for a minimum of ten (10) years. Wire and cable shall be designed, constructed and installed in accordance with the best practices of the trade, and shall operate satisfactorily when installed as specified herein and indicated on the Drawings. Only one (1) manufacturer for each wire and cable type shall be permitted.
- B. The wire and cable manufacturer shall be ISO 9000 registered.

#### 2.02 POWER WIRE AND CABLE

- A. Power cable and wire installed between the output terminals of a VFD and the respective motor shall consist of stranded copper conductor with insulation type XHHW/XHHW-2, rated 90°C and 600V.
- B. Power cable and wire shall consist of stranded, copper conductor with insulation type THHN/THWN-2, rated 90°C for dry locations and 75°C for wet locations.
- C. Conductors shall be stranded copper per ASTM-B8 and B-3, and Class B or C stranding contingent on the size unless otherwise specified. Minimum size wire shall be No. 12 AWG.
- D. Multi-conductor power cable assemblies shall be UL 1277 Listed, provided with a bonding conductor, and furnished with an overall PVC jacket.
- E. Power wire and cable shall be as manufactured by the Okonite Company, the Southwire Company, General Cable, or equal.

## 2.03 CONTROL CABLE

- A. 600 volt control cable shall consist of stranded, copper conductor with insulation type THHN/THWN-2, rated 90°C in dry locations and 75°C in wet locations.
- B. Conductors shall be stranded copper per ASTM B-8 and B-3, and Class B or C stranding contingent on the size unless otherwise specified. Minimum wire size shall be No. 14 AWG.
- C. Multi-conductor control cable assemblies shall be UL 1277 Listed, provided with a bonding conductor, and furnished with an overall PVC jacket.
- D. Control cable shall be as manufactured by the Okonite Company, the Southwire Company, General Cable, or equal.

## 2.04 LIGHTING AND RECEPTACLE WIRE

- A. The lighting and receptacle branch circuit wire shall consist of solid, copper conductors with insulation type THHN/THWN-2, rated 90°C in dry locations and 75°C for in wet locations.
- B. Conductors shall be solid copper per ASTM- B-3. Minimum size wire shall be No. 12 AWG.
- C. Lighting and receptacle wire shall be as manufactured by the Okonite Company, the Southwire Company, General Cable, or equal.

## 2.05 INSTRUMENTATION CABLE

- A. The instrumentation cable for analog signals shall be single, shielded, twisted pairs or triads with 600 volt insulation and shall have a 75°C (minimum) insulation rating.
- B. Conductors shall be tin or alloy coated (if available), soft, annealed copper, stranded per ASTM-B8, Class B stranding unless otherwise specified. Minimum size wire shall be No. 16 AWG.
- C. The instrumentation cable shall be Okoseal-N Type P-OS for single pair or triad applications and Okoseal-N Type SP-OS for multiple pair or triad applications as manufactured by the Okonite Company, Belden equivalent, Southwire Company equivalent, or equal.

## 2.06 SHIELDED VFD CABLE

- A. Where indicated on the Drawings, shielded VFD cable shall be provided for motors controlled by VFDs. The cable shall be 600V/1000V rated, with stranded tinned copper conductors, shielded, suitable for use with variable frequency drives. Cable shall be suitable for use in wet/dry locations, indoors and outdoors, in cable trays, in conduits, trenches, and in underground ducts and direct burial. The conductor shall be annealed stranded tinned copper per ASTM B3, B8, and B33.
- B. The insulation shall be rated for 90 degrees Celsius Wet/Dry operating temperature. The insulation material shall be XLPE with a XHHW-2 listing per UL 44. The insulated

conductors shall be cabled together with three (3) symmetrically placed ground wires. The ground wires shall have a minimum circular mil area equivalent to one circuit conductor. Fillers shall be included as necessary to make the cable round.

- C. The cabled assembly shall be shielded by applying helically a 5 mil copper tape. The shield shall provide 100% coverage over the assembly. All cables shall have a continuous overall outer jacket of Polyvinyl Chloride (PVC), suitable for 90°C use. The jacket shall be resistant to abrasion, rated for direct burial, sunlight resistant and flame resistant in accordance with UL 1277. Cable shall be as manufactured by Belden Wire and Cable, Okonite, General Cable, or AmerCable Inc.

## 2.07 CONDUCTOR IDENTIFICATION

- A. Conductors shall be identified using a color coding method. Color coding for individual power, control, lighting, and receptacle conductors shall be as follows:

- 1. 480/277V AC Power

- Phase A - BROWN
  - Phase B - ORANGE
  - Phase C - YELLOW
  - Neutral – GREY

- 2. 120/208V or 120/240V AC Power

- Phase A - BLACK
  - Phase B - RED
  - Phase C - BLUE
  - Neutral - WHITE

- 3. DC Power

- Positive Lead - RED
  - Negative Lead - BLACK

- 4. DC Control

- All wiring - BLUE

- 5. 120VAC Control

- 120 VAC control wire shall be RED except for a wire entering a motor control center compartment or control panel which is an interlock. This interlock conductor shall be color coded YELLOW.

- 6. 24VAC Control

- All wiring - ORANGE

- 7. Equipment Grounding Conductor

- All wiring - GREEN

- B. Individual conductors No. 2 AWG and smaller shall have factory color coded insulation. It is acceptable for individual conductors larger than No.2 AWG to be provided with factory color coded insulation as well, but it is not required. Individual conductors larger than No.2 AWG that are not provided with factory color coded insulation shall be identified by the use of colored tape in accordance with the requirements listed in Part 3 herein. Insulation colors and tape colors shall be in accordance with the color coding requirements listed above.
- C. Conductors that are a part of multi-conductor control cable assemblies shall have black insulation. The conductor number shall be printed on each conductor's insulation in accordance with ICEA S-58-679, Method 4. Each conductor within the cable assembly shall also be identified with a heat shrink tag with color coded background in accordance with the requirements listed in Part 3 herein. Background color shall be in accordance with the color coding requirements listed above.
- D. Conductors that are a part of multi-conductor power cable assemblies shall have black insulation. The conductor number shall be printed on each conductor's insulation in accordance with ICEA S-58-679, Method 4. Each conductor No.2 AWG and smaller within the cable assembly shall also be identified with a heat shrink tag with color coded background. Each conductor larger than No.2 AWG within the cable assembly shall also be identified by the use of colored tape. Heat shrink tags and colored tape shall be in accordance with the requirements listed in Part 3 herein. Tape color and heat shrink tag background color shall be in accordance with the color coding requirements listed above.

## 2.08 CABLE PULLING LUBRICANTS

- A. Cable pulling lubricants shall be non-hardening type and approved for use on the type of cable installed. Lubricant shall be Yellow #77 Plus by Ideal, Cable Gel by Greenlee, Poly-Gel by Gardner Bender, or equal.

## PART 3 -- EXECUTION

### 3.01 POWER, CONTROL, AND LIGHTING/RECEPTACLE WIRE AND CABLE INSTALLATION

- A. The wire and cable shall be installed as specified herein and indicated on the Drawings.
- B. The cables shall be terminated in accordance with the cable and/or termination product manufacturer's instructions for the particular type of cable.
- C. To minimize oxidation and corrosion, wire and cable shall be terminated using an oxide-inhibiting joint compound recommended for "copper-to-copper" connections. The compound shall be Penetrox E as manufactured by Burndy Electrical, or equal.
- D. Splices shall not be allowed in the underground concrete box systems. If splices are required, the Contractor shall obtain approval in writing from the Engineer prior to splicing. Splicing materials shall be barrel type butt splice connectors and heat shrink tubing as manufactured by 3M, Ideal, or equal. No splicing of instrumentation cable is allowed. The use of screw-on wire connectors (wire nuts) shall only be permitted for lighting and receptacle circuits.



E. Wire and Cable Sizes

1. The sizes of wire and cable shall be as indicated on the Drawings, or if not shown, as approved by the Engineer. If required due to field routing, the size of conductors and respective conduit shall be increased so that the voltage drop measured from source to load does not exceed 3%.

F. Additional Conductor Identification

1. In addition to the color coding identification requirements specified in Part 2 herein, individual conductors shall be provided with heat shrinkable identification tags. Identification tags for individual conductors shall have a white background where the conductor insulation is colored. Identification tags for individual conductors shall have a colored background where the conductor insulation is black. Background color shall match that of the taping provided on the individual black conductors.
2. Multi-conductor cables shall be provided with heat shrinkable identification tags in accordance with Part 2 herein.
3. All wiring shall be identified at each point of termination. This includes but is not limited to identification at the source, load, and in any intermediate junction boxes where a termination is made. The Contractor shall meet with the Owner and Engineer to come to an agreement regarding a wire identification system prior to installation of any wiring. Wire numbers shall not be duplicated.
4. Wire identification shall be by means of a heat shrinkable sleeve with appropriately colored background and black text. Wire sizes #14 AWG through #10 AWG shall have a minimum text size of 7 points. Wire sizes #8 AWG and larger shall have a minimum text size of 10 points. Sleeves shall be of appropriate length to fit the required text. The use of handwritten text for wire identification shall not be permitted.
5. Sleeves shall be suitable for the size of wire on which they are installed. Sleeves shall not be heat-shrunk onto control cables. Tags shall remain loose on cable to promote easier identification. For all other applications, sleeves shall be tightly affixed to the wire and shall not move. Sleeves shall be heat shrunk onto wiring with a heat gun approved for the application. Sleeves shall not be heated by any means which employs the use of an open flame. The Contractor shall take special care to ensure that the wiring insulation is not damaged during the heating process.
6. Sleeves shall be installed prior to the completion of the wiring terminations and shall be oriented so that they can be easily read.
7. Sleeves shall be polyolefin as manufactured by Brady, Seton, Panduit, or equal.
8. Wire identification in manholes, handholes, pull boxes, and other accessible components in the raceway system where the wiring is continuous (no terminations are made) shall be accomplished by means of a tag installed around the bundled group of individual conductors or around the outer conductor jacket of a multi-conductor cable. Identification shall utilize a FROM-TO system. Each group of

conductors shall consist of all of the individual conductors in a single conduit or duct. The tag shall have text that identifies the bundle in accordance with the 'FROM' and 'TO' column for that particular conduit number in the conduit and wire schedule. Minimum text size shall be 10 point. The tag shall be affixed to the wire bundle by the use of nylon wire ties, and shall be made of polyethylene as manufactured by Brady, Seton, Panduit, or equal.

9. Where colored tape is used to identify cables, it shall be wrapped around the cable with a 25% overlap and shall cover at least 2 inches of the cable.

#### H. Wiring Supplies

1. Only electrical wiring supplies manufactured under high standards of production and meeting the approval of the Engineer shall be used.
2. Rubber insulating tape shall be in accordance with ASTM Des. D119. Friction tape shall be in accordance with ASTM Des. D69.

#### I. Training of Cable

1. The Contractor shall furnish all labor and material required to train cables around cable vaults within buildings and in manholes and handholes in the outdoor underground duct system. Sufficient length of cable shall be provided in each handhole, manhole, and vault so that the cable can be trained and racked in an approved manner. In training or racking, the radius of bend of any cable shall be not less than the manufacturer's recommendation. The training shall be done in such a manner as to minimize chaffing. Reference Section 16118 – Underground Electrical.
2. Instrumentation cable shall be racked separate from other AC and DC wiring to maintain the required separation as follows:
  - a. 18 inches for 480/277VAC wiring
  - b. 12 inches for 208/120VAC wiring
  - c. 6 inches for 24VDC wiring

#### J. Conductor Terminations

1. Where wires are terminated at equipment which requires lugs, connections shall be made by solderless mechanical lug, crimp type ferrule, or irreversible compression type lugs. Reference individual equipment specification sections as applicable for additional termination requirements.
2. Where enclosure sizes and sizes of terminals at limit switches, solenoid valves, float switches, pressure switches, temperature switches, and other devices make terminations impractical due to the size of the field wiring, the Contractor shall terminate field wiring in an adjacent junction per the requirements of Section 16130 - Boxes, complete with terminal strips. Contractor shall install the smaller wiring from the device to the junction box in a conduit, using the terminal strip as the

means for joining the two different wire sizes. Splicing of wires in lieu of using terminal strips is not acceptable.

3. All spare conductors shall be terminated on terminal blocks mounted within equipment or junction boxes. Unless otherwise noted, coiling up of spare conductors within enclosure is not acceptable.

#### K. Pulling Temperature

1. Cable shall not be flexed or pulled when the temperature of the jacket is such that damage will occur due to low temperature embrittlement. When cable will be pulled with an ambient temperature of 40°F or less within a three (3) day period prior to pulling, the cable reels shall be stored three (3) days prior to pulling in a protected storage area with an ambient temperature of 55°F or more. Cable pulling shall be completed during the work day for which the cable is removed from the protected storage. Any remaining cable reels shall be returned to storage at the completion of the workday.

### 3.02 INSTRUMENTATION CABLE INSTALLATION

- A. The Contractor shall install all cable or conductors used for instrumentation wiring (4-20 mA DC, etc.) in conduit as specified in Section 16111 - Conduit. Only instrumentation cable as specified herein shall exclusively occupy these conduits. No other wiring for AC or discrete DC circuits shall be installed in these conduits.
- B. All shielding shall be continuous and shall be **grounded at one point only**.
- C. Where instrumentation cables are installed in panels, manholes, handholes, and other locations, the Contractor shall arrange wiring to provide maximum clearance between these cables and other conductors. Instrumentation cables shall not be installed in same bundle with conductors of other circuits.
- D. Special instrument cable shall be as specified or recommended by the manufacturer of the equipment or instruments requiring such wiring. Installation, storage, and terminations, shall be per manufacturer's recommendations.

### 3.03 SHIELDED VFD CABLE INSTALLATION

- A. The Contractor shall install all cable or conductors used for shielded VFD cable in conduit as specified in Section 16111 - Conduit. Only shielded VFD cable as specified herein shall exclusively occupy these conduits. No other wiring shall be installed in these conduits.

### 3.04 FIBER OPTIC CABLE INSTALLATION

- A. The Contractor shall install the fiber optic cable furnished by the General Contractor and/or the Instrumentation and Control Subcontractor. The cable shall be installed in its respective raceway system(s) as specified herein, indicated on the Drawings, and in accordance with the cable manufacturer's instructions. Prior to installation, the cable shall be tested on the reel to ensure integrity. The cable shall be tested immediately after installation to verify the integrity of the newly installed cable. Reference Division 17 for additional information regarding the fiber optic cable.

### 3.05 TESTING

- A. All testing shall be performed in accordance with the requirements of the General Conditions and Division 1. The following tests are required:
1. Shop Test
    - a. Cable and wiring shall be tested in accordance with the applicable ICEA Standards. Wire and cable shall be physically and electrically tested in accordance with the manufacturer's standards.
  2. Field Tests
    - a. After installation, all wires and cables shall be tested for continuity. Testing for continuity shall be "test light" or "buzzer" style.
    - b. After installation, some wires and cables shall be tested for insulation levels. Insulation resistance between conductors of the same circuit and between conductor and ground shall be tested. Testing for insulation levels shall be as follows:
      - (1) For #8 AWG and larger 600V power and control cable, apply 1,000 VDC from a Megaohmmeter for one (1) minute for all 600V wires and cables installed in lighting, control, power, indication, alarm and motor feeder circuits. Resistance shall be no less than 100 Megaohms. Insulation testing is not required for power and control cables smaller than #8 AWG.
      - (2) 600V instrumentation signal cable shall be tested from conductor to conductor, conductor to shield, and conductor to ground using a Simpson No. 260 volt-ohmmeter, or approved equal. The resistance value shall be 200 Megaohms or greater.
- B. Wires and cables shall be tested before being connected to motors, devices or terminal blocks.
- C. If tests reveal defects or deficiencies, the Contractor shall make the necessary repairs or shall replace the cable as directed by the Engineer, without additional cost to the Owner.
- D. All tests shall be made by and at the expense of the Contractor who shall supply all testing equipment. Test reports shall be submitted to the Engineer.

- END OF SECTION -

(EXHIBIT A)  
 TEST DATA - MEGOHMS  
 TEST NO. \_\_\_\_

Date:			Company:				
Time:			Location:				
Circuit:	Circuit Length:	Aerial:	Duct:	Buried:	No. of Conductors	Size:	AMG MCM Shld:
Insulation Material:			Insulation Thickness:		Voltage Rating:		Age:
Type: ____ Pothead ____ Terminal					Location:       Indoors____ Outdoors____		
Number and Type of Joints:							
Recent Operating History:							
Manufacturer:							
State if Potheads or Terminals were grounded during test:							
List associated equipment included in test:							
Miscellaneous Information:							

(EXHIBIT A)  
TEST DATA - MEGOHMS  
TEST NO. \_\_\_\_\_

Part Tested: Test Made: \_\_\_\_\_  
Hours/Days: \_\_\_\_\_  
After Shutdown: \_\_\_\_\_

Grounding Time: Dry Bulb Temperature: \_\_\_\_\_  
Wet Bulb Temperature: \_\_\_\_\_

Test Voltage: _____	Equipment Temperature: _____
	How Obtained: _____
	Relative Humidity: _____
	Absolute Humidity: _____
	Dew Point: _____

Megohmmeter: Serial Number: \_\_\_\_\_ Range: \_\_\_\_\_  
Voltage: \_\_\_\_\_ Calibration Date: \_\_\_\_\_

Test Connections	To Line To Earth To Ground	To Line To Earth To Ground	To Line To Earth To Ground	Test Connections	To Line To Earth To Ground	To Line To Earth To Ground	To Line To Earth To Ground
<input type="checkbox"/> Minute				5 Minutes			
<input type="checkbox"/> Minute				6 Minutes			
3/4 Minute				7 Minutes			
1 Minute				8 Minutes			
2 Minutes				9 Minutes			
3 Minutes				10 Minutes			
4 Minutes				10/1 Minutes			
				Ratio			

Remarks:

## SECTION 16130 - BOXES

### PART 1 -- GENERAL

#### 1.01 THE REQUIREMENT

- A. The scope of work under this Section includes furnishing and installing all pull boxes, junction boxes, and outlet boxes.
- B. Requirements for other boxes and enclosures are not included in this Section. Reference each specific Division 16 equipment Section for requirements related to that equipment's respective enclosure.
- C. Reference Section 16000, Basic Electrical Requirements, and Section 161111, Conduit.

#### 1.02 CODES AND STANDARDS

- A. Boxes shall be designed, manufactured, and/or listed to the following standards as applicable:
  - 1. UL 514A - Metallic Outlet Boxes
  - 2. UL 514C - Standard for Non-metallic Outlet Boxes, Flush Device Boxes, and Covers
  - 3. UL 50 – Enclosures for Electrical Equipment, Non-environmental Considerations
  - 4. UL 50E - Enclosures for Electrical Equipment, Environmental Considerations
  - 5. UL 1203 – Standard for Explosion-proof and Dust-ignition-proof Electrical Equipment for use in Hazardous (Classified) Locations.
  - 6. NEMA 250 – Enclosures for Electrical Equipment

#### 1.03 SUBMITTALS

- A. In accordance with the procedures and requirements set forth in the General Conditions and Section 01300, Submittals, the Contractor shall obtain from the equipment manufacturer(s) and submit the following:
  - 1. Shop Drawings
- B. Each submittal shall be identified by the applicable specification section.

#### 1.04 SHOP DRAWINGS

- A. Each submittal shall be complete in all respects, incorporating all information and data listed herein and all additional information required for evaluation of the proposed equipment's compliance with the Contract Documents.
- B. Partial, incomplete or illegible Submittals will be returned to the Contractor without review for resubmittal.

C. Shop drawings shall include but not be limited to:

1. Product data sheets for boxes, terminal strips, and all accessories

#### 1.05 OPERATION AND MAINTENANCE MANUALS

- A. The Contractor shall submit operation and maintenance manuals in accordance with the procedures and requirements set forth in the General Conditions and Division 1.
- B. As-built drawings showing dimensions, internal box layout, terminal strip information, and terminal strip identification information shall be provided for all junction boxes. As-built drawings are not required for pull boxes or outlet boxes.

#### 1.06 IDENTIFICATION

- A. Each pull and junction box shall be identified with the box name as indicated on the Contract Drawings (e.g. PPB-XXX, CJB-YYY) or as directed by the Engineer. A nameplate shall be securely affixed in a conspicuous place on each box. Nameplates shall be as specified in Section 16195, Electrical – Identification.

### PART 2 -- PRODUCTS

#### 2.01 MANUFACTURERS

- A. The equipment covered by this Specification is intended to be standard equipment of proven performance as manufactured by reputable concerns. Equipment shall be designed, constructed, and installed in accordance with the best practices of the trade, and shall operate satisfactorily when installed as shown on the Drawings.

#### 2.02 PULL AND JUNCTION BOXES

##### A. General

1. All pull and junction boxes shall be UL listed and labeled.
2. Pull and junction boxes shall not be provided with eccentric or concentric knockouts.
3. Pull and junction boxes mounted embedded in concrete shall be UL listed for embedment.
4. Where metallic boxes are used, they shall be of all welded construction. Tack welded boxes are not acceptable.

##### B. Pull Boxes

1. All pull boxes shall be provided with a matching gasketed cover. For covers with dimensions of 24 inches by 24 inches or less, the cover shall be held in place by machine screws. Other screw types are not acceptable. For covers with dimensions greater than 24 inches by 24 inches, the cover shall be hinged and held



in place by screw-operated clamp mechanisms. Hinge pins shall be removable. Clamp mechanism material of construction shall match that of the associated box.

2. Pull boxes shall not have any wire terminations inside, other than those for grounding/bonding. A ground bar shall be provided with the necessary number of screw type terminals. Twenty (20) percent of the total amount of terminals otherwise required for the pull box (minimum of two) shall be provided as spare terminations. Boxes requiring any other wire terminations shall be furnished and installed in accordance with the requirements for junction boxes herein.
3. Pull boxes shall be 6 inches wide by 6 inches tall by 4 inches deep, minimum. For applications requiring larger boxes, the box shall be sized in accordance with the fill requirements and dimensional requirements of the NEC.
4. Barriers shall be provided in pull boxes to isolate conductors of different voltages, types, and functions. Barrier material of construction shall match that of the box. Isolation shall be provided between the following groups:
  - a. Power wiring
  - b. AC control wiring
  - c. DC control wiring
  - d. Instrumentation wiring

#### C. Junction Boxes

1. Junction boxes used for lighting and receptacle circuits only shall be provided with a matching gasketed cover held in place by machine screws. Other screw types are not acceptable.
2. Junction boxes for all uses other than lighting and receptacle circuits shall be provided with a hinged, gasketed cover. Hinge pins shall be removable. Cover shall be held in place by screw-operated clamp mechanisms. Clamp mechanism material of construction shall match that of the associated box.
3. Barriers shall be provided in junction boxes to isolate conductors and terminal blocks of different voltages, types, and functions. Barrier material of construction shall match that of the box. Isolation shall be provided between the following groups:
  - a. Power wiring
  - b. AC control wiring
  - c. DC control wiring
  - d. Instrumentation wiring
4. Junction boxes used for lighting and receptacle circuits only shall be allowed to have screw-on (wire nut) type connectors for wire terminations/junctions.

5. Junction boxes for all uses other than lighting and receptacle circuits shall be provided with terminal strips, consisting the necessary number of screw type terminals. Current carrying parts of the terminal blocks shall be of ample capacity to carry the full load current of the circuits connected, with a 10A minimum capacity. Terminal strips shall be rated for the voltage of the circuits connected. A separate ground bar shall be provided with the necessary number of screw type terminals. Twenty (20) percent of the total amount of terminals otherwise required for the junction box (minimum of two) shall be provided as spare terminations. When barriers are provided within the box, separate terminal strips shall be provided in each barrier area. Terminals shall be lettered and/or numbered to conform to the wiring labeling scheme in place on the project.
6. Junction boxes shall be 6 inches wide by 6 inches tall by 4 inches deep, minimum. For applications requiring larger boxes, the box shall be sized in accordance with the fill requirements and dimensional requirements of the NEC. Terminal blocks (including spare terminals) shall be considered when sizing the junction box.

D. Enclosure Types and Materials

1. In non-hazardous locations, pull and junction boxes shall be furnished with the following enclosure type and material of construction, dependent upon the designation of the area in which they are to be installed. Area designations are indicated on the Drawings. Where enclosure types and materials are called out on the drawings however, provide enclosure type and material as indicated on the drawing.

AREA DESIGNATION	ENCLOSURE TYPE AND MATERIAL
Indoor Wet Process Area	NEMA 4X, Type 316 Stainless Steel
Indoor Dry Process Area	NEMA 12, Painted Steel
Indoor Dry Non-process Area	NEMA 1, Painted Steel
Type 1 Chemical Storage/Transfer Area	NEMA 4X, Fiberglass or PVC
Type 2 Chemical Storage/Transfer Area	NEMA 4X, Type 316 Stainless Steel
All Outdoor Areas	NEMA 4X, Type 316 Stainless Steel

2. In hazardous locations, pull and junction boxes shall be furnished with the following enclosure type and material of construction, dependent upon the classification of the area in which they are to be installed. Area classifications are indicated on the Drawings.

AREA CLASSIFICATION	ENCLOSURE TYPE AND MATERIAL
Class 1, Division 1, Group D	NEMA 7, Die Cast Aluminum
Class 1, Division 2, Group D	NEMA 4X, Type 316 Stainless Steel
Class 2, Division 1, Group F	NEMA 9, Die Cast Aluminum
Class 2, Division 2, Group F	NEMA 4X, Type 316 Stainless Steel

3. Non-metallic enclosures, NEMA 7 enclosures, and NEMA 9 enclosures shall be provided with threaded integral conduit hubs.

## 2.03 OUTLET BOXES

### A. General

1. Outlet boxes shall be provided with a trim appropriate for the wiring device installed inside. Reference Section 16141, Wiring Devices, for outlet box trim requirements. An appropriate outlet box trim is required to achieve the NEMA rating of the outlet boxes as specified herein.

### B. Surface Mount Outlet Boxes

1. Outlet boxes shall be the deep type, no less than 2.5 inches deep.
2. Outlet boxes shall be provided in single or multi-gang configuration as required, sized in accordance with the requirements of the NEC.
3. In non-hazardous locations, outlet boxes shall be furnished with the following enclosure type and material of construction, dependent upon the designation of the area in which they are to be installed. Area designations are indicated on the Drawings. Where enclosure types and materials are called out on the drawings however, provide enclosure type and material as indicated on the drawing.

<b>AREA DESIGNATION</b>	<b>ENCLOSURE TYPE AND MATERIAL</b>
Indoor Wet Process Area	NEMA 4X, Cast Aluminum
Indoor Dry Process Area	NEMA 1, Cast Aluminum
Indoor Dry Non-process Area	NEMA 1, Cast Aluminum
Type 1 Chemical Storage/Transfer Area	NEMA 4X, PVC
Type 2 Chemical Storage/Transfer Area	NEMA 4X, Cast Aluminum
All Outdoor Areas	NEMA 4X, Cast Aluminum

4. In hazardous locations, outlet boxes shall be furnished with the following enclosure type and material of construction, dependent upon the classification of the area in which they are to be installed. Area classifications are indicated on the Drawings.

<b>AREA CLASSIFICATION</b>	<b>ENCLOSURE TYPE AND MATERIAL</b>
Class 1, Division 1, Group D	NEMA 7, Die Cast Aluminum
Class 1, Division 2, Group D	NEMA 4X, Cast Aluminum
Class 2, Division 1, Group F	NEMA 9, Die Cast Aluminum
Class 2, Division 2, Group F	NEMA 4X, Cast Aluminum

5. Outlet boxes shall be provided with integral threaded conduit hubs mounted external to the box. Boxes with threaded conduit hubs mounted internal to the box or as a part of the box wall are not acceptable.

### C. Flush Mount Outlet Boxes

1. Outlet boxes shall be no less than 2-1/8 inches deep, and 4-11/16 inches square. Boxes shall be UL listed and labeled. Pre-punched single diameter conduit knockouts are acceptable; however, concentric and eccentric knockouts are not acceptable.
2. Outlet boxes mounted flush in CMU walls shall be made of galvanized, tack welded steel, and suitable for installation in masonry walls. Sectional type boxes are not acceptable for this application.
3. Outlet boxes mounted flush in gypsum walls shall be made of galvanized pressed steel. Tack welded boxes are not acceptable for this application. Sectional type boxes are not acceptable for this application.
4. Outlet boxes mounted cast into concrete shall be concrete tight, and shall be made of galvanized steel or PVC.

## PART 3 -- EXECUTION

### 3.01 INSTALLATION

#### A. Pull and Junction Boxes

1. Pull boxes and junction boxes shall be solidly attached to structural members prior to installation of conduit and set true and plumb. Boxes shall not be supported by their associated conduits.
2. Wooden plugs are not permitted for securing boxes to concrete. Appropriately rated anchors specifically suited for use in concrete shall be used.
3. Box penetrations for conduits shall be made with a punch tool, and penetrations shall be of the size required for the conduit entry and/or hub. Oversized penetrations in boxes are not acceptable.
4. Watertight conduit hubs shall be provided for boxes where a NEMA 4X enclosure rating is specified. Reference Section 16111, Conduit, for conduit hub requirements.
5. Pull and junction boxes may be installed flush mounted in gypsum, concrete or CMU walls where appropriate provided that covers are easily removed or opened.
6. Pull and junction boxes shall be provided in the enclosure type and material of construction required for the area in which it is installed. Reference the requirements in Part 2 herein, and the area designations indicated on the Drawings.

#### B. Outlet Boxes

1. Outlet boxes shall be solidly attached to structural members prior to installation of conduit and set true and plumb. Boxes shall not be supported by their associated conduits.

2. Wooden plugs are not permitted for securing boxes to concrete. Appropriately rated anchors specifically suited for use in concrete shall be used.
3. Flush mounted outlet boxes shall be arranged and located so that tile and grout lines fit closely around the boxes, and so placed that the cover or device plate shall fit flush to the finished wall surface.
4. Outlet boxes shall be flush mounted in finished areas and other areas where practical. Flush mounted outlet boxes shall not be installed in hazardous areas and type 1 or 2 chemical storage/transfer areas.
5. For the below-named items, mounting heights from finished floor, or finished grade to top is applicable, depending on the type of wiring device to be installed in the outlet box. Mounting heights for outlet boxes shall be as follows, unless otherwise specified herein, indicated on the Drawings, or required by the Americans with Disability Act (ADA):
  - a. Light switches and wall mounted occupancy sensors, 48 inches
  - b. Receptacles in indoor dry process/non-process areas, 16 inches
  - c. Receptacles in indoor wet process areas and all indoor chemical storage/transfer areas, 48 inches
  - d. Receptacles in outdoor locations, 24 inches
  - e. Ceiling mounted occupancy sensors, as indicated on the Drawings
6. Outlet boxes shall be provided in the material of construction required for the area in which it is installed. Reference the requirements in Part 2 herein, and the area designations indicated on the Drawings.

- END OF SECTION -

## SECTION 16190 - SUPPORTING DEVICES

### PART 1 -- GENERAL

#### 1.01 THE REQUIREMENT

- A. The Contractor shall furnish and install structural supports for mounting and installing all conduit, electrical equipment, lighting, alarm systems, instrumentation, and communications equipment furnished under this Contract.
- B. Equipment shall be installed strictly in accordance with recommendations of the manufacturer and best practices of the trade resulting in a complete, operable, and safe installation. The Contractor shall obtain written installation manuals from the equipment manufacturer prior to installation.
- C. Reference Section 16000, Basic Electrical Requirements.

#### 1.02 SUBMITTALS

- A. In accordance with the procedures and requirements set forth in the General Conditions and Section 01300, Submittals, the Contractor shall obtain from the equipment manufacturer and submit the following:
  - 1. Shop drawings
  - 2. Structural support calculations (if required)
- B. Each submittal shall be identified by the applicable Specification section.

#### 1.03 SHOP DRAWINGS

- A. Each submittal shall be complete in all respects, incorporating all information and data listed herein and all additional information required for evaluation of the proposed equipment's compliance with the Contract Documents.
- B. Partial, incomplete, or illegible submittals will be returned to the Contractor without review for resubmittal.
- C. Shop drawings shall include but not be limited to:
  - 1. Product data sheets.
  - 2. Complete assembly, layout, installation, and foundation drawings with clearly marked dimensions.

## PART 2 -- PRODUCTS

### 2.01 MANUFACTURERS

- A. The equipment covered by this Specification is intended to be standard equipment of proven performance as manufactured by reputable concerns. Equipment shall be designed, constructed, and installed in accordance with the best practices of the trade, and shall operate satisfactorily when installed as shown on the Drawings.

### 2.02 MATERIALS

- A. Support channel shall be 1-5/8" by 1-5/8" minimum, with 12 gage material thickness.
- B. Support channel, support channel fittings, and threaded rod shall be furnished with the following material of construction, dependent upon the designation of the area in which they are to be installed. Area designations are indicated on the Drawings.

<b>AREA DESIGNATION</b>	<b>MATERIAL OF CONSTRUCTION</b>
Indoor Wet Process Area	Type 3016Stainless Steel
Indoor Dry Process Area	Hot Dipped Galvanized Steel
Indoor Dry Non-process Area	Hot Dipped Galvanized Steel
Type 1 Chemical Storage/Transfer Area	Fiberglass
Type 2 Chemical Storage/Transfer Area	Type 316 Stainless Steel
All Outdoor Areas	Type 316 Stainless Steel
All Hazardous Areas	Type 316 Stainless Steel

- C. Fastening hardware (bolts, nuts, washers, and screws) shall be furnished with the following material of construction, dependent upon the designation of the area in which they are to be installed. Area designations are indicated on the Drawings.

<b>AREA DESIGNATION</b>	<b>MATERIAL OF CONSTRUCTION</b>
Indoor Wet Process Area	Type 316 Stainless Steel
Indoor Dry Process Area	Type 316 Stainless Steel
Indoor Dry Non-process Area	Type 316 Stainless Steel
Type 1 Chemical Storage/Transfer Area	Fiberglass
Type 2 Chemical Storage/Transfer Area	Type 316 Stainless Steel
All Outdoor Areas	Type 316 Stainless Steel
All Hazardous Areas	Type 316 Stainless Steel

## PART 3 -- EXECUTION

### 3.01 INSTALLATION

#### A. Concrete or Masonry Inserts

1. The Contractor shall be responsible for the furnishing and installation of all conduit sleeves, anchor bolts, masonry inserts, and similar devices required for installation of equipment furnished under this Contract.
2. If a time delay for the arrival of any special inserts or equipment drawings, etc. occurs, the Contractor may, if permitted by the Engineer, make arrangements for providing approved recesses and openings in the concrete or masonry and, upon subsequent installation, the Contractor shall be responsible for filling in such recesses and openings. Any additional costs that may be incurred by this procedure shall be borne by the Contractor.
3. The Contractor shall furnish leveling channels for all switchgear, switchboards, motor control centers, and similar floor mounted equipment. The leveling channels shall be provided for embedment in the equipment housekeeping pads. Coordination of the installation of these channels with the concrete pad is essential and required. Pad height shall be as required to maintain concrete coverage of the reinforcement bars while not causing associated equipment to exceed the maximum mounting height requirements of the NEC.

#### B. Support Fastening and Locations

1. All equipment fastenings to columns, steel beams, and trusses shall be by beam clamps or welded. No holes shall be drilled in the steel.
2. All holes made in reflected ceilings for support rods, conduits, and other equipment shall be made adjacent to ceiling grid bars where possible, to facilitate removal of ceiling panels.
3. Support channel shall be provided wherever required for the support of starters, switches, panels, and miscellaneous equipment.
4. All equipment, devices, and raceways that are installed on the dry side of a water bearing wall shall not be installed directly onto the wall. Support channel shall be used to allow ventilation air to pass behind the equipment, devices, or raceway.
5. All supports shall be rigidly bolted together and braced to make a substantial supporting framework. Where possible, control equipment shall be grouped together and mounted on a single framework.
6. Aluminum support members shall not be installed in direct contact with concrete. Stainless steel or non-metallic "spacers" shall be used to prevent contact of aluminum with concrete.



7. Actual designs for supporting framework should take the nature of a picture frame of support channels and bracket with a plate for mounting the components. The Contractor is responsible for the design of supporting structure; he shall submit design details to the Engineer for acceptance before proceeding with the fabrication.
8. Wherever dissimilar metals come into contact, the Contractor shall isolate these metals as required with neoprene washers, nine (9) mil polyethylene tape, or gaskets.
9. For all installations where fiberglass supporting materials are required, the Contractor shall submit structural calculations and the details of the proposed system of support. Structural calculations shall be signed and sealed by a registered professional engineer in the State of Florida.
10. For the following installations where conduits are provided with a support system suspended from the above or attached to a vertical structure, the Contractor shall submit structural calculations and details of the proposed system of support. Structural calculations shall be signed and sealed by a registered professional engineer in the Florida.
  - a. A quantity of twelve (12) or more conduits trade size 1" and smaller are proposed for a conduit support rack.
  - b. A quantity of eight (8) or more conduits trade sizes 1 1/2" to 2 1/2" are proposed for a conduit support rack.
  - c. A quantity of four (4) or more conduits trade sizes 3" and larger are proposed for a conduit support rack.

- END OF SECTION -

## SECTION 16195 - ELECTRICAL - IDENTIFICATION

### PART 1 -- GENERAL

#### 1.01 THE REQUIREMENT

- A. All electrical equipment shall be properly identified in accordance with these Specifications and the Contract Drawings. All switchgear, switchboards, motor control centers, variable frequency drives, lighting and distribution panelboards, combination starters, control panels, pull and junction boxes, enclosures, disconnect switches, control stations, and similar equipment shall be identified in the manner described, or in an equally approved manner.
- B. The types of electrical identification specified in this section include, but are not limited to, the following:
  - 1. Operational instructions and warnings.
  - 2. Danger signs.
  - 3. Equipment/system identification signs.
  - 4. Nameplates.

#### 1.02 SIGNS

- A. "DANGER-HIGH-VOLTAGE" signs shall be securely mounted on the entry doors of all electrical rooms.

#### 1.03 LETTERING AND GRAPHICS

- A. The Contractor shall coordinate names, abbreviations, and other designations used in the electrical identification work with the corresponding designations shown, specified or scheduled. Provide numbers, lettering, and wording as indicated or, if not otherwise indicated, as recommended by manufacturers or as required for proper identification and operation/maintenance of the electrical systems and equipment.

#### 1.04 SUBMITTALS

- A. In accordance with the procedures and requirements set forth in the General Conditions and Section 01300, Submittals, the Contractor shall obtain from the equipment manufacturer and submit shop drawings. Each submittal shall be identified by the applicable specification section.

#### 1.05 SHOP DRAWINGS

- A. Each submittal shall be complete in all respects, incorporating all information and data listed herein and all additional information required for evaluation of the proposed equipment's compliance with the Contract Documents.

- B. Partial, incomplete, or illegible submittals will be returned to the Contractor without review for resubmittal.
- C. Shop drawings shall include but not be limited to:
  - 1. Product data sheets.

## PART 2 -- PRODUCTS

### 2.01 MANUFACTURERS

- A. The material covered by these Specifications is intended to be standard material of proven performance as manufactured by reputable concerns. Material shall be fabricated, constructed, and installed in accordance with the best practices of the trade, and shall operate satisfactorily when installed as specified herein and shown on the Drawings.

### 2.02 NAMEPLATES

- A. Nameplates shall be engraved, high pressure plastic laminate, white with black lettering.
- B. Nameplates shall be attached to NEMA 4X enclosures utilizing UL-recognized mounting kits designed to maintain the overall UL Type rating of the enclosure. Mounting kit fasteners shall be stainless steel Type AHK10324X as manufactured by Hoffman, or equal.

### 2.03 HIGH VOLTAGE SIGNS

- A. Standard "DANGER" signs shall be of baked enamel finish on 20 gage steel; of standard red, black and white graphics; 14 inches by 10 inches size except where 10 inches by 7 inches is the largest size which can be applied where needed, and except where a larger size is needed for adequate identification.

### 2.04 CONDUIT IDENTIFICATION

- A. Conduit identification shall be as specified in Section 16111, Conduit.

### 2.05 WIRE AND CABLE IDENTIFICATION

- A. Field installed wire and cable identification shall be as specified in Section 16123, Low Voltage Wire and Cable.
- B. A plastic laminate nameplate shall be provided at each panelboard, motor control center, switchgear assembly, and switchboard assembly. This nameplate shall be used to clearly convey the conductor identification means used at that piece of equipment (i.e. Phase A=Brown, Phase B=Orange, C = Yellow).
- C. Wiring identification for factory installed wiring in equipment enclosures shall be as specified in the respective section.

## 2.06 BOX IDENTIFICATION

- A. Pull, junction and device box identification shall be as specified in Section 16130 – Boxes.

## PART 3 -- EXECUTION

### 3.01 NAMEPLATES

- A. Nameplates shall be attached to the equipment enclosures with (2) two stainless steel sheet metal screws for nameplates up to 2-inches wide. For nameplates over 2-inches wide, four (4) stainless steel sheet metal screws shall be used, one (1) in each corner of the nameplate. The utilization of adhesives is not permitted.

### 3.02 OPERATIONAL IDENTIFICATION AND WARNINGS

- A. Wherever reasonably required to ensure safe and efficient operation and maintenance of the electrical systems and electrically connected mechanical systems and general systems and equipment, including prevention of misuse of electrical facilities by unauthorized personnel, install plastic signs or similar equivalent identification, instruction, or warnings on switches, outlets, and other controls, devices, and covers or electrical enclosures. Where detailed instructions or explanations are needed, provide plasticized tags with clearly written messages adequate for the intended purposes. Signs shall be attached as specified above for nameplates.

### 3.03 POWER SOURCE IDENTIFICATION

- A. After installation of all field equipment (i.e. valves, motors, fans, unit heaters, instruments, etc) install nameplates at each power termination for the field equipment. Nameplate data shall include equipment designation (tag number), power source (MCC number, panelboard, etc), circuit number, conduit number from schedule and voltage/phase.
- B. Contractor to coordinate with the Engineer and the Owner regarding exact nameplate placement during construction.
- C. Nameplates shall be as specified herein.

- END OF SECTION -

## SECTION 16480 - LOW VOLTAGE ELECTRIC MOTORS

### PART 1 -- GENERAL

#### 1.01 THE REQUIREMENT

- A. The Contractor shall furnish all labor, materials, tools and equipment necessary for furnishing, installing, connecting, testing and placing into satisfactory operation all low voltage electric motors as shown on the Drawings and specified herein. All motors required for this Contract shall comply with this Section, however, any deviations from this specification shall take precedence wherever they occur in the motor-driven equipment specifications.

#### 1.02 SUBMITTALS

- A. In accordance with the procedures and requirements set forth in the General Conditions and Section 01300, Submittals, the Contractor shall obtain from the equipment manufacturer and submit the following:
  - 1. Shop Drawings.
  - 2. Spare Parts List.
  - 3. Special Tools List.
- B. Each submittal shall be identified by the applicable specification section.

#### 1.03 SHOP DRAWINGS

- A. Each submittal shall be complete in all respects, incorporating all information and data listed herein and all additional information required for evaluation of the proposed equipment's compliance with the Contract Documents.
- B. Partial, incomplete or illegible submittals will be returned to the Contractor without review for resubmittal.
- C. Individual shop drawings for electric motors shall be submitted in accordance with the procedures and requirements set forth in the General Conditions and Section 01300, Submittals, unless submitted as a part of the shop drawings for the driven equipment.
- D. Shop drawings for electric motors shall include motor data sheets, dimensioned drawings, wiring diagrams (space heaters, temperature devices, etc.) identifying electric characteristics and design, mechanical construction, manufacturer's name, type and pertinent specifications for the use intended, along with the name of the equipment to be driven. For motors rated 50 horsepower or more, submittal of motor data for acceptance shall include, as a minimum, the following:
  - a. Manufacturer's type and frame designation
  - b. Horsepower rating
  - c. Time rating (per NEMA Standards)
  - d. Ambient temperature rating

- e. Insulation system designation
- f. RPM at rated load
- g. Frequency
- h. Number of phases
- i. Rated-load amperes
- j. Voltage
- k. Code letter (starting KVA per horsepower)
- l. Design letter for integral horsepower induction motors (per NEMA Standards)
- m. Service factor
- n. Temperature rise at full load and at service factor load
- o. Efficiency at 1/4, 1/2, 3/4 and full load
- p. Power factor at 1/4, 1/2, 3/4 and full load
- q. Motor outline, dimensions and weight
- r. Insulation system description
- s. Horsepower required by connected machine at specified conditions (load curves) shall be supplied for all compressors, propeller and positive displacement pumps.

The foregoing data shall also be verified after manufacture and shall be included with the information to be furnished in the operation and maintenance manuals specified.

- E. The shop drawing information shall be complete and organized in such a way that the Engineer can determine if the requirements of these Specifications are being met. Copies of technical bulletins, technical data sheets from "soft-cover" catalogs, and similar information which is "highlighted" or somehow identifies the specific equipment items the Contractor intends to provide are acceptable and shall be submitted.

## PART 2 -- PRODUCTS

### 2.01 MANUFACTURERS

- A. The equipment covered by this Specification is intended to be standard equipment of proven performance as manufactured by reputable concerns. Equipment shall be designed, constructed and installed in accordance with the best practices of the trade, and shall operate satisfactorily when installed as shown on the Drawings.
- B. Electric motors shall be manufactured by Baldor/Reliance Electric Company; Nidec Motors; Toshiba Industrial and Power Systems, Inc.; Siemens Energy & Automation, Inc.; General Electric Company; or equal.

### 2.02 MATERIALS AND CONSTRUCTION

- A. Motors shall be built in accordance with the latest standards of NEMA, including, but not limited to MG-1 and MG-2, IEEE, ANSI and to the requirements specified herein.
- B. Type
  - 1. Unless otherwise noted, motors specified herein shall be polyphase squirrel cage, NEMA Design B, or single phase capacitor or repulsion start induction motors. Special equipment requiring a motor drive with unusual characteristics shall be equipped with a definite purpose motor to meet the necessary requirements.

2. Unless otherwise shown or specified, all motors 1/2 horsepower or larger shall be three-phase, 60 Hertz, NEMA Design B, squirrel cage induction motors designed for operation at 208 or 480 volts as specified herein or shown on the Drawings.
3. Unless otherwise specified in the driven equipment specification, or as required by the dynamic characteristics of the load as determined by the manufacturer of the machine to be driven, all polyphase squirrel cage motors shall have torque and locked rotor current characteristics as specified for NEMA Design B motors.
4. All motors 2 horsepower and smaller shall have windings encapsulated with a flexible epoxy compound, or insulated with a flexible epoxy compound, or insulated with the manufacturer's premium quality system which shall be subject to acceptance by the Engineer.
5. All motors above 2 horsepower shall have stator windings vacuum impregnated with a polyester insulation compound.
6. Unless otherwise noted, all motors smaller than 1/2 horsepower shall be standard single-phase capacitor start or repulsion start induction type designed for operation on 120 volts or 208 volts, 60 Hz alternating current. Small fan motors less than 1/4 HP may be split-phase or shaded pole type. Shaded pole motors rated more than 1/4 horsepower will not be approved. Fractional horsepower motors shall be completely equipped with all necessary auxiliary components for starting and be labeled as "Thermally Protected". Insulation shall be Class F with Class B rise, except that submersible motors shall have epoxy encapsulation. Unless otherwise noted, the motors shall be totally enclosed, fan-cooled. Small fan motors may be of the open type where they are suitably protected from moisture dripping and lint accumulation. Motors shall be provided with sealed ball bearings lubricated for 10 years normal use.
7. Where specified, vertical hollowshaft motors shall be designed to carry the motors', pumps', and associated equipment's full thrust. The motors shall be equipped with grease lubricated spherical roller thrust bearings and lower radial guide bearings. Vertical hollowshaft motors shall be fitted with nonreversing ratchet assemblies where specified. Vertical adjustment shall be provided by means of a lockable nut at the top of the shaft.
8. Vertical hollowshaft motors shall have adequate thrust bearings to carry all motor loads and any other operating equipment loads. Horizontal motors shall not be installed where subjected to external thrust loads.

#### C. Rating

1. Each motor shall develop ample torque for its required service through its acceleration range and throughout its rated load range. The rating of the motors offered shall, in no case, be less than the horsepower shown on the Drawings or elsewhere specified. It should be noted that the motor sizes indicated on the Drawings or as otherwise specified herein, are motor sizes required to operate the specific equipment which is specified. Higher rated motor sizes may be determined from the actual equipment submitted, approved, purchased, and installed. Overload protection, starters, disconnect switches, and other necessary equipment shall be furnished and installed for the actual motor sizes required at no additional cost.

2. Motor ratings shall be based on continuous operation in an ambient temperature of 40 deg C. The maximum temperature rise for open and drip proof type motors shall not exceed 90 degrees C, and for totally enclosed type motors shall not exceed 80 degrees C.

#### D. Insulation

1. Insulation shall be as specified for each particular type or class of motor. The insulation system shall provide a high dielectric strength, long life covering for the windings which may be required to operate in a continually damp and chemically contaminated environment. The insulation shall be tropicalized, resistant to attack by moisture, fungus, acids, alkalis, abrasives, and mechanical and thermal shock. Leads shall be sealed with a non-wicking, non-hygroscopic insulation material.
2. Motor insulation resistance may be checked at any time after delivery to the job site or during the warranty period. Encapsulated motor stators may be subjected to insulation testing while completely submerged in water. Any motor not meeting the requirements specified herein will be rejected and shall be promptly replaced at no cost to the Owner.
3. The locked rotor KVA/HP input at full voltage for 10 horsepower motors and larger shall not exceed that permitted for Code Letter "J", except for specialized equipment requiring a motor drive with special definite characteristics.
4. Unless otherwise specified, non-inverter duty motors shall be furnished with a Class F insulation system. Unless otherwise specified, inverter duty motors shall be furnished with a Class H insulation system. In either case, temperature rise shall be limited to that for Class B insulation. Output torque and speed characteristics of each motor shall be suitable to operate the driven equipment through the full range of acceleration and operating load conditions without exceeding the nameplates current rating, and/or temperature rise.

#### E. Nameplates

1. The motor manufacturer's nameplates shall be engraved or stamped on stainless steel and fastened to the motor frame with No. 4 or larger oval head stainless steel screws or drive pins. Nameplates shall include as a minimum, items a through m as listed in Article 1.03 in addition to that required by NEMA standards. The nameplate shall be positioned so as to be readily visible for inspection in the assembled machine.

#### F. Design

1. Motors shall be designed to accelerate and drive the connected equipment under all normal operating conditions without exceeding nameplate ratings.
2. Motors specified for operation with variable frequency drives shall be inverter duty and shall be designed to output 100 percent of nameplate horsepower under continuous duty service without exceeding the temperature rise specified herein when controlled by the actual drives furnished. Inverter duty motors shall be



designed to operate down to 10% of full load speed without the need for a line powered cooling fan.

3. Unless otherwise specified, electric motors shall be furnished with service factors in accordance with NEMA MG-1 as follows:

<b>Type of Motor</b>	<b>Service Factor</b>
Non-inverter Duty	1.15
Inverter Duty	1.0

4. Design selection with respect to the driven machine shall be such that the requirements do not exceed 85 percent of the motors' maximum rating modified by service factor, ambient temperature, enclosure, altitude and electrical service. The electrical service conditions shall be assumed to be 10 percent undervoltage, 5 percent underfrequency, and 3 percent voltage unbalance. Altitude shall be assumed to be the project site elevation plus 10 percent. Ambient temperature shall be assumed to be 104 degrees F (40 degrees C) in interior and exterior locations, and 122 degrees F (50 degrees C) within housings or enclosures; except where higher temperatures may be encountered within or on individual items of equipment. The applicable paragraphs of NEMA MG-1 shall be used in making the design selection.
5. Motors used with belt drives shall have sliding bases to provide for belt take up.
6. Terminal boxes shall be oversized, and of sufficient size to accommodate the required quantity and size of conduits. Gasketed terminal boxes shall be furnished with all splash-proof and totally enclosed motors. NEMA ratings of the terminal boxes shall be suited for the application. Motors located in hazardous locations shall be furnished with terminal boxes suitable for the specific Class, Division, and Group. Terminal boxes shall be sized to accommodate accessory equipment such as motor differential current transformers.
7. Terminal boxes for horizontal motors shall be located on the left-hand side when viewing the motor from the drive shaft end and shall be so designed that conduit entrance can be made from above, below, or either side of the terminal box. For installations at existing facilities, coordinate terminal box locations as required to match existing conduit locations.
8. Motors larger than 250hp shall be manufactured with the six stator coil leads wired to the motor junction box for application in a differential relay scheme. Current transformers shall be provided by the motor manufacturer and installed in the factory. All ground connections and current transformer connections shall be made in the factory.

#### G. Construction

1. Frames, mounting means, and shafts shall meet NEMA Standards for the horsepower, RPM, and enclosure selected. Enclosures shall be selected according to the degree of mechanical protection required and shall not be of aluminum construction. All motors shall have a manufacturer's standard shop machinery finish, consisting of a rust-resisting priming coat of zinc chromate and a finish coat of alkyd machinery enamel. Reference Section 09900, Painting.

2. Motors shall have cast iron frames and a heavy gauge steel terminal box, with neoprene gaskets between the frame and the box and between the box and its cover. A grounding lug(s) shall be provided inside the terminal box.
3. Motors weighing more than 50 pounds shall be equipped with at least one lifting eye. All lifting hardware shall be corrosion resistant.
4. Motors located in Class I or II, Division 1 hazardous locations shall bear a U.L.-674 label and shall be provided with a breather/drain approved for the hazardous location. The U.L. listed breather/drain shall prevent the entrance of contaminants while allowing moisture to drain out of the motor.
5. When located outdoors, or elsewhere if specified, motors shall be totally enclosed, non-ventilated (TENV) or totally enclosed, fan-cooled (TEFC) machines, unless otherwise noted. Totally enclosed motors shall be provided with two (2) 1/4 inch drain holes drilled through the bottom of the frame, which allows complete drainage of the frame. Where specified, TEFC motors controlled by a variable frequency drive shall be provided with a separately powered cooling fan motor that runs at 60HZ to ensure proper cooling of the motor at low speeds. Cooling fan motor shall be suitable for 120VAC, single phase operation.
6. Unless otherwise specified in the equipment specifications, motors rated 100 horsepower or greater located outdoors, in unheated structures, in below grade areas, or as otherwise indicated, shall be furnished with space heaters and embedded motor winding high temperature switches with leads brought out to the motor terminal box. Space heaters shall be suitable for 120VAC operation and for a maximum surface temperature of less than 200 degrees C. Space heaters shall be of sufficient wattage to maintain the internal temperature of the motor at approximately 10 degrees C above the ambient temperature when the motor is not running.

Embedded motor winding temperature switches shall operate at temperatures well below the temperature rating of the motor winding insulation system. Motor winding temperature switches are not required where other temperature monitoring devices (e.g. RTD's) are specified.

7. Unless otherwise specified in the equipment specifications, motors rated 200HP or greater that are controlled by a VFD shall be furnished with resistance thermal detectors (RTD's) embedded in the stator windings, two per phase. RTD's shall be pre-wired to terminal blocks located in a separate terminal box as specified herein.
8. Unless otherwise specified in the equipment specifications, motors rated less than 200HP that are controlled by a VFD shall be furnished with motor winding high temperature switches embedded in the stator windings with the leads brought out to the motor terminal box.
9. If so specified and when located in indoor areas which are heated and weatherproof, motors shall be open drip-proof machines. Ventilation openings shall be arranged to prevent the entrance of drops of liquid or solid particles at any angle from zero to 15 degrees downward from vertical.

10. Unless otherwise specified, or required, motors rated less than 200 horsepower shall be furnished with bearings of the grease lubricated, antifriction ball type with conveniently located grease fittings and drain plugs. A means of preventing bearings from becoming overgreased shall be provided. Bearings shall have a minimum B-10 life of 20,000 hours.
11. Rotors shall be statically and dynamically balanced. Rotor windings shall be one-piece cast aluminum. Where applicable, rotors shall be constructed with integral fins.

#### H. Power Factor and Efficiency

1. All motors, including vertical hollowshaft motors, in the range of 1-500 horsepower, inclusive, shall be designed specifically for energy efficiency and high power factor. The motor efficiency and power factor shall meet or exceed the values listed in the table below when the motors are tested in accordance with the NEMA preferred test method IEEE 112A, Method B, Dynamometer. Each motor shall meet the minimum guaranteed efficiency value indicated in the tables below. All tests shall be performed in accordance with the procedures contained in NEMA Standard MG1-12.58.

**TABLE 12-11  
FULL-LOAD EFFICIENCIES OF ENERGY EFFICIENT MOTORS  
ENCLOSED MOTORS**

HP	2 POLE		4 POLE		6 POLE		8 POLE	
	Nominal Efficiency	Minimum Efficiency	Nominal Efficiency	Minimum Efficiency	Nominal Efficiency	Minimum Efficiency	Nominal Efficiency	Minimum Efficiency
1	75.5	72	82.5	80	80	77	74	70
1.5	82.5	80	84	81.5	85.5	82.5	77	74
2	84	81.5	84	81.5	86.5	84	82.5	80
3	85.5	82.5	87.5	85.5	87.5	85.5	84	81.5
5	87.5	85.5	87.5	85.5	87.5	85.5	85.5	82.5
7.5	88.5	86.5	89.5	87.5	89.5	87.5	85.5	82.5
10	89.5	87.5	89.5	87.5	89.5	87.5	88.5	86.5
15	90.2	88.5	91	89.5	90.2	88.5	88.5	86.5
20	90.2	88.5	91	89.5	90.2	88.5	89.5	87.5
25	91	89.5	92.4	91	91.7	90.2	89.5	87.5
30	91	89.5	92.4	91	91.7	90.2	91	89.5
40	91.7	90.2	93	91.7	93	91.7	91	89.5
50	92.4	91	93	91.7	93	91.7	91.7	90.2
60	93	91.7	93.6	92.4	93.6	92.4	91.7	90.2
75	93	91.7	94.1	93	93.6	92.4	93	91.7
100	93.6	92.4	94.5	93.6	94.1	93	93	91.7
125	94.5	93.6	94.5	93.6	94.1	93	93.6	92.4
150	94.5	93.6	95	94.1	95	94.1	93.6	92.4
200	95	94.1	95	94.1	95	94.1	94.1	93
250	95.4	94.5	95	94.1	95	94.1	94.5	93.6
300	95.4	94.5	95.4	94.5	95	94.1		
350	95.4	94.5	95.4	94.5	95	94.1		
400	95.4	94.5	95.4	94.5				
450	95.4	94.5	95.4	94.5				
500	95.4	94.5	95.8	95				

**TABLE 12-12  
FULL-LOAD EFFICIENCIES FOR NEMA PREMIUM™ EFFICIENCY ELECTRIC MOTORS  
RATED 600 VOLTS OR LESS (RANDOM WOUND)  
OPEN MOTORS**

HP	2 POLE		4 POLE		6 POLE	
	Nominal Efficiency	Minimum Efficiency	Nominal Efficiency	Minimum Efficiency	Nominal Efficiency	Minimum Efficiency
1	77	74	85.5	82.5	82.5	80
1.5	84	81.5	86.5	84	86.5	81.5
2	85.5	82.5	86.5	84	87.5	81.5
3	85.5	82.5	89.5	84	88.5	86.5
5	86.5	84	89.5	84	89.5	87.5
7.5	88.5	86.5	91	89.5	90.2	88.5
10	89.5	87.5	91.7	90.2	91.7	90.2
15	90.2	88.5	93	91.7	91.7	90.2
20	91	89.5	93	91.7	92.4	91
25	91.7	90.2	93.6	92.4	93	91.7
30	91.7	90.2	94.1	93	93.6	92.4
40	92.4	91	94.1	93	94.1	93
50	93	91.7	94.5	93.6	94.1	93
60	93.6	92.4	95	94.1	94.5	93.6
75	93.6	92.4	95	94.1	94.5	93.6
100	93.6	92.4	95.4	94.5	95	94.1
125	94.1	93	95.4	94.5	95	94.1
150	94.1	93	95.8	95	95.4	94.5
200	95	94.1	95.8	95	95.4	94.5
250	95	94.1	95.8	95	95.4	94.5
300	95.4	94.5	95.8	95	95.4	94.5
350	95.4	94.5	95.8	95	95.4	94.5
400	95.8	95	95.8	95	95.8	95
450	95.8	95	96.2	95.4	96.2	95.4
500	95.8	95	96.2	95.4	96.2	95.4

**NOTES:**

- (1) Motor data for continuous duty, NEMA Design B, 1.15 service factor, 40 degrees Celsius ambient, Class F insulation, 3 phase, 460 volt, at listed speed rating.
  - (2) TEFC efficiencies apply to both horizontal and vertical motors.
2. Motors rated 50 horsepower or greater shall be individually tested at the factory before shipment, with a copy of test results provided for the Engineer, to assure compliance with the efficiency and power factor specifications.

## 2.03 TOOLS, SUPPLIES AND SPARE PARTS

- A. Each motor shall be furnished with all special tools necessary to disassemble, service, repair, and adjust the equipment. All spare parts as recommended by the equipment manufacturer shall be furnished to the Owner by the Contractor.

## PART 3 -- EXECUTION

### 3.01 INSTALLATION

- A. Motors shall be installed as shown on the Drawings and in accordance with the manufacturer's installation instructions.

### 3.02 DELIVERY, STORAGE, AND HANDLING

- A. Motors shall be properly protected from weather hazards. Motors shall not be allowed to be wrapped tightly in plastic while outdoors. Motors delivered to the site which will not be put in service for a time in excess of 30 calendar days, whether in storage or installed, shall have the shafts rotated a minimum of five (5) rotations every 30 days.
- B. Motors provided with space heaters shall have temporary power applied to the heaters no later than 30 calendar days after delivery to the site until permanent power can be applied to the heaters.
- C. Motors that, in the opinion of the Engineer, have not been properly protected shall be inspected by the manufacturer's representative. Any required corrections for testing shall be made at the Contractor's expense prior to acceptance and/or use.
- D. All motors shall operate without any undue noise or vibration and shall show no signs of phase unbalance.

### 3.03 TESTING

- A. All tests shall be performed in accordance with the requirements of the General Conditions and Division 1. The following tests are required:
  - 1. Witnessed Shop Tests
    - a. All motors shall be shop tested and inspected in accordance with the equipment manufacturer's standard procedures. The manufacturer's testing and inspection procedures shall demonstrate that the equipment tested conforms to the requirements specified, all other applicable requirements, and shall be approved by the Engineer. At least 10 days notice shall be given the Engineer prior to tests and inspection dates.
    - b. In addition to the efficiency and power factor testing specified herein, each motor shall be tested to determine compliance with the applicable requirements of the IEEE, ANSI and NEMA. Tests shall be as follows:

- (1) Motors less than 50 HP
  - (a) Each motor shall be subjected to a standard, short commercial test including the following:
    - i) Running current, no load
    - ii) Locked rotor current
    - iii) High potential
    - iv) Winding resistance
    - v) Bearing inspection
- (2) Motors between 50 and 100 HP
  - (a) Each motor shall be subjected to the above tests and shall be furnished with certified test results.
- (3) Motors larger than 100 HP
  - (a) Each motor shall be furnished with certified test results. Each motor shall be subjected to a complete test consisting of full load heat run, percent slip, running load current, locked rotor current, breakdown torque (calculated), starting torque, winding resistance, high potential, secondary current and voltage at collector rings (wound rotor), efficiencies at 100, 75 and 50 percent of full load, power factors at 100, 75 and 50 percent of full load and bearing inspection. Tests will be witnessed by the Engineer where specifically indicated.
- (4) Test Reports
  - (a) All test results for motors over 100 horsepower shall be submitted to the Engineer for approval. Copies of witnessed test raw data shall be submitted to the Engineer immediately upon completion of such tests.

## 2. Field Tests

- a. Field tests shall be performed in accordance with the requirements specified in the General Conditions, Division 1, and Section 16000, Basic Electrical Requirements.
- b. All electric motors furnished for this project one (1) horsepower or larger shall have the information required in the following tabulation completed. See Exhibit "A" on following page.
- c. All field testing shall be witnessed by the Engineer.

(EXHIBIT A)

MOTOR TEST RECORD					
Motor Identification Remarks	Location	Specified Horsepower	Nameplate Horsepower	Nameplate Amperage (FLA)	Measured Amperage Under Normal Operating Conditions

- END OF SECTION -



## SECTION 16902 - ELECTRIC CONTROLS AND RELAYS

### PART 1 -- GENERAL

#### 1.01 THE REQUIREMENT

- A. The Contractor shall furnish, install, test, and place in satisfactory operation all electric controls and relays as specified herein and indicated on the Drawings.
- B. Electrical control and relay systems shall be assembled using NEMA rated components. International Electrotechnical Commission (IEC) standards are not acceptable.
- C. Reference Section 01010 – Summary of Work, Section 16000 – Basic Electrical Requirements and Section 16195 – Electrical Identification.

#### 1.02 CODES AND STANDARDS

- A. Products specified herein shall be in conformance with or listed to the following standards as applicable:
  - 1. NEMA 250 – Enclosures for Electrical Equipment
  - 2. UL 508A – Standard for Industrial Control Panels
  - 3. UL-1203 – Standard for Explosion-proof and Dust-ignition-proof Electrical Equipment for use in Hazardous (Classified) Locations.
  - 4. ANSI/ISA 12.12.01-2013 – Nonincendive Electrical Equipment for use in Class I and II, Division II Hazardous (Classified) locations.

#### 1.03 SUBMITTALS

- A. In accordance with the procedures and requirements set forth in the General Conditions and Section 01300, Submittals, the Contractor shall obtain from the equipment manufacturer and submit the following:
  - 1. Shop Drawings
  - 2. Spare Parts List
- B. Each submittal shall be identified by the applicable specification section.

#### 1.04 SHOP DRAWINGS

- A. Each submittal shall be complete in all respects, incorporating all information and data listed herein and all additional information required for evaluation of the proposed equipment's compliance with the Contract Documents.

- B. Partial, incomplete or illegible submittals will be returned to the Contractor without review for resubmittal.
- C. Shop drawings shall include but not be limited to:
  - 1. Product data sheets.
- D. The shop drawing information shall be complete and organized in such a way that the Engineer can determine if the requirements of these Specifications are being met. Copies of technical bulletins, technical data sheets from "soft-cover" catalogs, and similar information which is "highlighted" or somehow identifies the specific equipment items the Contractor intends to provide are acceptable and shall be submitted.

## PART 2 -- PRODUCTS

### 2.01 CONTROL COMPONENTS

#### A. Manufacturers

- 1. Control components shall be manufactured by Eaton, The Square D Company, General Electric, Allen-Bradley, Siemens Energy and Automation, or Engineer approved equal.

#### B. Pilot Devices

##### 1. General

- a. All pilot devices shall be provided with a legend plate. Legend plates shall have a white background and black lettering and indicate the function of the respective pilot device. The text shown on the Drawings or indicated in the specifications shall be used as the basis for legend plate engraving (i.e. HAND-OFF-AUTO, RUN, EMERGENCY STOP, etc).
- b. All pilot devices shall be selected and properly installed to maintain the NEMA 250 rating of the enclosure in which they are installed. All pilot devices shall be UL 508 Listed.
- c. All pilot devices shall be 30.5mm in diameter, unless otherwise indicated. 22mm devices are not acceptable.
- d. Pilot devices for all electrical equipment under this Contract shall be of the same type and manufacturer unless otherwise specified herein or indicated on the Drawings.
- e. In Class 1 Division 2 hazardous locations, pilot devices shall be the hermetically-sealed type, constructed in accordance with ANSI/ISA 12.12.01.

2. Pushbuttons

- a. Pushbuttons shall be non-illuminated, black in color, and have momentary style operation unless otherwise indicated on the Drawings.
- b. Pushbuttons shall have the quantity of normally closed and/or normally open contacts as indicated on the Drawings and as required. In addition to the required contacts, one (1) spare normally open and one (1) spare normally closed contact shall be installed at each pushbutton. Contacts shall be rated for 5A at 250VAC/DC (minimum), but no less than required for the application.
- c. Pushbuttons shall be provided with a full guard around the perimeter of the button. Where a lockout style pushbutton is specified or indicated on the Drawings, provide a padlockable guard.

3. Selector Switches

- a. Selector switches shall be non-illuminated, black in color, and have the number of maintained positions as indicated on the Drawings and as required. Handles shall be the extended type that provide a greater surface area for operation.
- b. Selector switches shall have the quantity of normally closed and/or normally open contacts as indicated on the Drawings and as required. In addition to the required contacts, one (1) spare normally open and one (1) spare normally closed contact shall be installed at each selector switch. Contacts shall be rated for 5A at 250VAC/DC (minimum), but no less than required for the application.
- c. Where indicated in the Drawings or Specifications, provide spring return positions.
- d. Selector switches shall be provided with an indexing component that fits into the keyed portion of the cutout for the device and prevents the switch from spinning when operated.

4. Indicating Lights

- a. Indicating lights shall LED type, with the proper voltage rating to suit the application, and push-to-test feature.
- b. Indicating light lens colors shall be as required in equipment specifications and/or as indicated on the Drawings. If lens colors are not indicated, the following colors shall be used:

Red	-	"Run", "On", "Open"
Green	-	"Off", "Closed"
Amber	-	"Alarm", "Fail"
White	-	"Control Power On"

5. Emergency Stop and Tagline Switches

- a. Emergency stop switches shall be non-illuminated, red in color, with a minimum 35mm diameter mushroom head. Once activated, switch shall maintain its position and require a manual pull to release/reset.
- b. Tagline switches shall have a plunger that activates upon tension from the associated safety cable. Once activated, switch shall maintain its position and require a manual release/reset.
- c. Emergency stop and tagline switches shall have the quantity of normally closed and/or normally open contacts as indicated on the Drawings and as required. In addition to the required contacts, one (1) spare normally open and one (1) spare normally closed contact shall be installed at each switch. Contacts shall be rated for 5A at 250VAC/DC (minimum), but no less than required for the application.

C. Relays and Timers

1. General

- a. Relays and timers shall be furnished with an integral pilot light for positive indication of coil energization.
- b. Relays and timers shall have tubular pin style terminals with matching 11-pin DIN rail mount socket. Spade or blade style terminals are not acceptable.
- c. Relays and timers for all electrical equipment under this Contract shall be of the same type and manufacturer unless otherwise specified herein or indicated on the Drawings.

2. Control and Pilot Relays

- a. Miniature or "ice-cube" type relays are not acceptable.
- b. Relays shall have coil voltage as required to suit the application and/or as indicated on the Drawings.
- c. Relays shall be provided with contacts rated for 10A (resistive), minimum, at 120/240 VAC and 28 VDC. Relays shall have 3-pole, double-throw (3PDT) contact arrangement.

3. Time Delay Relays

- a. Timers delay relays shall utilize electronic timing technology. Mechanical timing devices are not acceptable.
- b. Relays shall have coil voltage as required to suit the application and/or as indicated on the Drawings.

- c. Relays shall be provided with contacts rated for 10A (resistive), minimum, at 120/240 VAC and 28 VDC. Relays shall have double-pole double-throw (DPDT) contact arrangement.
  - d. Time delay ranges shall be as indicated on the Drawings and/or as required to suit the application. Timing range shall be adjustable from the front of the relay. On delay and off delay timer configurations shall be provided as indicated on the Drawings and/or as required to suit the application.
4. Elapsed Time Meters
- a. Elapsed time meters shall be non-resettable type with no less than a 4 digit display. Coil voltage shall be as required to suit the application and/or as indicated on the Drawings.

#### D. Control Terminal Blocks

- 1. Control terminal blocks shall be assembled on non-current carrying galvanized steel DIN mounting rails securely bolted to the enclosure or subpanel. Terminals shall be tubular screw type with pressure plate that will accommodate wire size range of #22 - #8 AWG.
- 2. Control terminal blocks shall be single tier with a minimum rating of 600 volts and 20A. Separate terminal strips shall be provided for each type of control used (i.e. 120VAC vs. 24VDC). Quantity of terminals shall be provided as required to suit the application. In addition, there shall be a sufficient quantity of terminals for the termination of all spare conductors.
- 3. Terminals shall be marked with a permanent, continuous marking strip, with each terminal numbered. One side of each terminal shall be reserved exclusively for incoming field conductors. Common connections and jumpers required for internal wiring shall not be made on the field side of the terminal.

#### 2.02 LOCAL CONTROL STATIONS

- A. Local control stations shall be installed complete with pushbuttons, selector switches, indicating lights, and other devices as indicated on the Drawings.
- B. Specific devices installed in local control stations shall be provided in accordance with the requirements specified elsewhere in this Section.
- C. In non-hazardous locations, local control stations shall be furnished with the following enclosure type and material of construction, dependent upon the designation of the area in which they are to be installed. Area designations are indicated on the Drawings.

<b>AREA DESIGNATION</b>	<b>ENCLOSURE TYPE AND MATERIAL</b>
Indoor Wet Process Area	NEMA 4X, Type 316 Stainless Steel
Indoor Dry Process Area	NEMA 12, Die Cast Zinc
Indoor Dry Non-process Area	NEMA 12, Die Cast Zinc
Indoor Type 1 Chemical Storage/Transfer Area	NEMA 4X, Fiberglass or Thermoplastic Polyester
Indoor Type 2 Chemical Storage/Transfer Area	NEMA 4X, Type 316 Stainless Steel
All Outdoor Areas	NEMA 4X, Type 316 Stainless Steel

- D. In hazardous locations, local control stations shall be furnished with the following enclosure type and material of construction, dependent upon the classification of the area in which they are to be installed. Area classifications are indicated on the Drawings.

<b>AREA CLASSIFICATION</b>	<b>ENCLOSURE TYPE AND MATERIAL</b>
Class 1, Division 1, Group D	NEMA 7, Die Cast Aluminum
Class 1, Division 2, Group D	NEMA 4X, Type 316 Stainless Steel
Class 2, Division 1, Group F	NEMA 9, Die Cast Aluminum
Class 2, Division 2, Group F	NEMA 9, Die Cast Aluminum

- E. Non-metallic enclosures, NEMA 7 enclosures, and NEMA 9 enclosures shall be provided with threaded integral conduit hubs. Conduit hubs shall be external to the enclosure.
- F. Local control stations for use in non-hazardous locations shall be UL-508 Listed. Local control stations for use in Class 1 Division 1 and Class 2 Divisions 1/2 hazardous locations shall be UL-1203 Listed. Local control stations for use in Class 1 Division 2 hazardous locations shall be in accordance with ANSI/ISA 12.12.01-2013.
- G. Provide a nameplate on each local control station in accordance with Section 16195, Electrical Identification. The name and/or number of the equipment associated with each control station shall be engraved on the nameplate, followed by the words "LOCAL CONTROL STATION".

### 2.03 ELECTRONIC SHOCK RELAY

- A. Electronic shock relays shall be installed complete with enclosures, as indicated on the Drawings. Electronic shock relay shall provide supplemental protection for clarifier drive mechanisms against over-torque conditions. Relay enclosure shall be furnished with viewing window to allow operator to view relay current meter and settings.
- B. Electronic shock relays shall be suitable for monitoring AC induction motor circuits.
- C. Electronic shock relays shall be suitable for operation on 120VAC, 60 Hz control power supply.
- D. Electronic shock relays shall have the following features and functions:

1. Load current meter: Instantaneous motor current shall be displayed to facilitate load current setting adjustments.
  2. Load current setting: Shall allow the operator to adjust the load current set point. When load current exceeds the set point for a period in excess of the shock time setting, the relay shall trip. Load current setting range shall be 30% to 130% of motor current.
  3. Shock time setting: Shall allow the operator to adjust the time delay for load currents in excess of the load current set point, after which, the relay shall trip. Shock time range shall be from 0.2 to 3 seconds.
  4. Impact setpoint: Shall allow the operator to set a motor current set point, which when exceeded for 5/100ths of a second, shall cause the relay to trip.
  5. Start time setting: Shall allow the operator to set a time delay during which load currents in excess of the setpoint are allowed, as required for motor starting.
  6. Manual test feature: Shall allow the operator to verify proper operation of the relay.
  7. Manual reset: Manual reset shall be required after the relay has tripped.
  8. Relay shall provide visual indication when control power is available, and when relay has tripped.
- E. Furnish with Form C relay contacts rated 0.2A minimum at 250VAC.
- F. Shock relay shall be Tsubaki TSB151M or equal.

## PART 3 -- EXECUTION

### 3.01 INSTALLATION

- A. Local control stations shall be provided in the enclosure type and material of construction required for the area in which it is installed. Reference the requirements in Part 2 herein, and the area designations indicated on the Drawings.
- B. All control components shall be mounted in a manner that will permit servicing, adjustment, testing, and removal without disconnecting, moving, or removing any other component. Components mounted on the inside of panels shall be mounted on removable plates and not directly to the enclosure. Mounting shall be rigid and stable unless shock mounting is required otherwise by the manufacturer to protect equipment from vibration. Component's mounting shall be oriented in accordance with the component manufacturer's and industries' standard practices.
- C. Pilot devices shall be properly bonded to the equipment enclosure door where they are installed. If proper bonding cannot be achieved through the locknuts that affix the device in place, a green colored bonding screw shall be provided on the pilot device. The bonding screw shall be bonded to the equipment enclosure through the use of an insulated green bonding conductor.

- D. Local control station covers shall be bonded to the local control station enclosure through the use of an insulated green bonding conductor.
- E. Wiring to devices at each local control station shall be provided with enough slack to permit the local control station cover to be removed and pulled at least 6 inches away from the enclosure.
- F. Terminal strips, relays, timers, and similar devices shall not be installed on the rear of the panel/cabinet doors. Terminal strips, relays, timers, and similar devices shall not be installed on the side walls of panel/cabinet interiors without written permission from the Engineer.
- G. Contractor shall coordinate shock relay settings with clarifier dynamic testing, per section 16902. Closely monitor shock relay load current during dynamic testing as required for determining load current settings. Note maximum current load achieved during test. Adjust start time, impact, and shock time settings as required to adequately protect the clarifier drive mechanism in the event that the clarifier drive mechanism torque switch fails. Adjust these settings as required to avoid nuisance tripping. Shock time setting shall be adjusted as required to allow the torque switch to trip before the shock relay trips during an over-torque condition.

- END OF SECTION -



**DIVISION 17 – INSTRUMENTATION**

## SECTION 17000 - CONTROL AND INFORMATION SYSTEM SCOPE AND GENERAL REQUIREMENTS

### PART 1 -- GENERAL

#### 1.01 SCOPE

- A. The Contractor shall provide, through the services of an instrumentation and control system subcontractor, all components, system installation services, as well as all required and specified ancillary services in connection with the Instrumentation, Control and Information System. The System includes all materials, labor, tools, fees, charges and documentation required to furnish, install, test and place in operation a complete and operable instrumentation, control and information system as shown and/or specified. The system shall include all digital hardware and software, PLCs (Programmable Logic Controllers), HMIs (Human Machine Interfaces) screens, SCADA (Supervisory Control and Data Acquisition Systems), signal and data transmission systems, control panel hardware, interconnecting wiring and such accessories as shown, specified, and/or required to provide the functions indicated.
- B. The scope of the work to be performed under this Division includes but is not limited to the following:
1. The Contractor shall retain overall responsibility for the instrumentation and control system as specified herein.
  2. Furnish and install a complete PLC logic program to replace the existing PLC logic program in PLC-8. The logic shall incorporate both the existing equipment monitoring and control strategies and the status and alarm signals for Clarifier No. 3 (listed in the Section 17920 and shown on the Instrumentation Drawings). Refer to Sections 17300 and 17950 for more information.
  3. Modify the existing SCADA HMI screens as required to support the PLC-8 modifications and as required to incorporate the status and alarm signals for Clarifier No. 3, as listed in the Section 17920 and shown on the Instrumentation Drawings. Refer to Sections 17300 and 17950 for more information.
  4. Furnish and install all control panel hardware required to add the Clarifier No. 3 digital signals listed in the Section 17920 and shown on the Instrumentation Drawings to the PLC-8 control panel. This work shall include, but is not limited to furnishing and installing: surge suppressors, terminal blocks, din rails, fuses, internal wiring, wiring labels, wire channels and wiring terminations.
  5. Perform the final termination and testing of all signal wiring in PLC-8 control cabinet.
  6. Provide system testing, calibration, training and startup services as specified herein and as required to make all systems fully operational.

- C. It is the intent of the Contract Documents to construct a complete and working installation. Items of equipment or materials that may reasonably be assumed as necessary to accomplish this end shall be supplied whether or not they are specifically stated herein.

## 1.02 RELATED ITEMS

- A. Field mounted switches, torque switches, limit switches, solenoid valve operators, and other instrumentation and controls furnished with mechanical or electrical equipment not listed in the instrument schedule shall be furnished, installed, tested and calibrated as specified under other Divisions.
- B. Additional and related work performed under Division 16 includes the following:
  - 1. Instrument A.C. power source and disconnect switch for process instrumentation, A.C. grounding systems, and A.C. power supplies for all equipment, control panels and accessories furnished under Division 17.
  - 2. Conduit and raceways for all instrumentation and control system signal wiring, grounding systems and special cables.
  - 3. Instrumentation and control system signal wiring.
  - 4. Furnish and install grounding systems for all digital equipment, local control panels, and instrumentation provided under Division 17. Grounding systems shall be complete to the equipment provided under Division 17, ready for termination by the instrumentation subcontractor.
  - 5. Termination of all instrumentation and control system signal wiring at all equipment furnished under other divisions of the Specifications.
  - 6. Final wiring and termination to A.C. grounding systems and to A.C. power sources (e.g. panelboards, motor control centers, and other sources of electrical power).

## 1.03 GENERAL INFORMATION AND DESCRIPTION

- A. Where manufacturers are named for a particular item of equipment, it is intended as a guide to acceptable quality and performance and does not exempt such equipment from the requirements of these Specifications or Drawings.
- B. In order to centralize responsibility, it is required that all equipment (including field instrumentation and control system hardware and software) offered under this Division shall be furnished and installed by the instrumentation subcontractor, or under the supervision of the instrumentation subcontractor, who shall assume complete responsibility for proper operation of the instrumentation and control system equipment, including that of coordinating all signals, and furnishing all appurtenant equipment.
- C. The Contractor shall retain total responsibility for the proper detailed design, fabrication, inspection, test, delivery, assembly, installation, activation, checkout, adjustment and operation of the entire instrumentation and control system as well as equipment and controls furnished under other Divisions of the Specifications. The Contractor shall be

responsible for the delivery of all detailed drawings, manuals and other documentation required for the complete coordination, installation, activation and operation of mechanical equipment, equipment control panels, local control panels, field instrumentation, control systems and related equipment and/or systems and shall provide for the services of a qualified installation engineer to supervise all activities required to place the completed facility in stable operation under full digital control.

- D. The instrumentation and control system shall be capable of simultaneously implementing all real-time control and information system functions, and servicing all operator service requests as specified, without degrading the data handling and processing capability of any system component.
- E. Control system inputs and outputs are listed in the Input/Output Schedule, Section 17920. This information, together with the functional control descriptions, process and instrumentation diagrams, and electrical control schematics, describes the real-time monitoring and control functions to be performed. In addition, the system shall provide various man/machine interface and data reporting functions as specified in the software sections of this Specification.
- F. The mechanical, process, and electrical drawings indicate the approximate locations of field instruments, control panels, systems and equipment as well as field-mounted equipment provided by others. The instrumentation subcontractor shall examine the mechanical, process and electrical drawings to determine actual size and locations of process connections and wiring requirements for instrumentation and controls furnished under this Contract. The instrumentation subcontractor shall inspect all equipment, panels, instrumentation, controls and appurtenances either existing or furnished under other Divisions of the Specifications to determine all requirements to interface same with the control and information system. The Contractor shall coordinate the completion of any required modifications with the associated supplier of the item furnished.
- G. The instrumentation subcontractor shall review and approve the size and routing of all instrumentation and control cable and conduit systems furnished by the electrical subcontractor for suitability for use with the associated cable system.
- H. The Contractor shall coordinate the efforts of each supplier to aid in interfacing all systems. This effort shall include, but shall not be limited to, the distribution of approved shop drawings to the electrical subcontractor and to the instrumentation subcontractor furnishing the equipment under this Division.
- I. The Contractor shall be responsible for providing a signal transmission system free from electrical interference that would be detrimental to the proper functioning of the instrumentation and control system equipment.
- J. The CITY shall have the right of access to the subcontractor's facility and the facilities of his equipment suppliers to inspect materials and parts; witness inspections, tests and work in progress; and examine applicable design documents, records and certifications during any stage of design, fabrication and tests. The instrumentation subcontractor and his equipment suppliers shall furnish office space, supplies and services required for these surveillance activities.

- K. The terms "Instrumentation", "Instrumentation and Control System", and "Instrumentation, Control and Information System" shall hereinafter be defined as all equipment, labor, services and documents necessary to meet the intent of the Specifications.

#### 1.04 INSTRUMENTATION AND CONTROL SYSTEM SUBCONTRACTORS

- A. Instrumentation and control system subcontractors shall be regularly engaged in the detailed design, fabrication, installation, and startup of instrumentation and control systems for wastewater treatment facilities. Instrumentation and control system subcontractors shall have a minimum of five years of such experience, and shall have completed a minimum of three projects of similar type and size as that specified herein. Where specific manufacturers and/or models of major hardware or software products (PLC, HMI software, LAN, etc.) are specified to be used on this project, the instrumentation and control system subcontractor shall have completed at least one project using that specified hardware or software. As used herein, the term "completed" shall mean that a project has been brought to final completion and final payment has been made. Any instrumentation and control system subcontractor that has been subject to litigation or the assessment of liquidated damages for nonperformance on any project within the last five calendar years shall not be acceptable.
- B. Acceptable instrumentation and control system subcontractors shall be CC Control Corporation or Curry Controls Company; no substitutions.

#### 1.05 DEFINITIONS

- A. Solid State: Wherever the term solid state is used to describe circuitry or components in the Specifications, it is intended that the circuitry or components shall be of the type that convey electrons by means of solid materials such as crystals or that work on magnetic principles such as ferrite cores. Vacuum tubes, gas tubes, slide wires, mechanical relays, stepping motors or other devices will not be considered as satisfying the requirements for solid state components of circuitry.
- B. Bit or Data Bit: Whenever the terms bit or data bit are used in the Specification, it is intended that one bit shall be equivalent to one binary digit of information. In specifying data transmission rate, the bit rate or data bit rate shall be the number of binary digits transmitted per second and shall not necessarily be equal to either the maximum pulse rate or average pulse rate.
- C. Integrated Circuit: Integrated circuit shall mean the physical realization of a number of circuit elements inseparably associated on or within a continuous body to perform the function of a circuit.
- D. Mean Time Between Failures (MTBF): The MTBF shall be calculated by taking the number of system operating hours logged during an arbitrary period of not less than six months and dividing by the number of failures experienced during this period plus one.
- E. Mean Time to Repair (MTTR): The MTTR shall be calculated by taking the total system down time for repair over an arbitrary period of not less than six months coinciding with that used for calculation of MTBF and dividing by the number of failures causing down time during the period.

- F. Availability: The availability of a non-redundant device or system shall be related to its MTBF and MTTR by the following formula:

$$A = 100 \times (\text{MTBF}/(\text{MTBF} + \text{MTTR})) \text{ Percent}$$

The availability of a device or system provided with an automatically switched backup device or system shall be determined by the following formula:

$$A = A_2 + 1 - ((1-A_1) \times (1-A_1))$$

where:

A1 = availability of non-redundant device or system  
A2 = availability of device or system provided with an automatically switched backup device or system

- G. Abbreviations: Specification abbreviations include the following:

A	-	Availability
ADC	-	Analog to Digital Converter
AI	-	Analog Input
AO	-	Analog Output
AVAIL	-	Available
BCD	-	Binary Coded Decimal
CSMA/CD	-	Carrier Sense Multiple Access/Collision Detect
CPU	-	Central Processing Unit
CRC	-	Cyclic Redundancy Check
CRT	-	Cathode Ray Tube
CS	-	Control Strategy
DAC	-	Digital to Analog Converter
DBMS	-	Data Base Management System
DI	-	Discrete Input
DMA	-	Direct Memory Access
DO	-	Discrete Output
DPDT	-	Double Pole, Double Throw
DVE	-	Digital to Video Electronics
EPROM	-	Erasable, Programmable Read Only Memory
FDM	-	Frequency Division Multiplexing
FSK	-	Frequency Shift Keyed
HMI	-	Human Machine Interface (Software)

I/O	-	Input/Output
LAN	-	Local Area Network
LDFW	-	Lead-Follow
MCC	-	Motor Control Center
MTBF	-	Mean Time Between Failures
MTTR	-	Mean Time To Repair
OS	-	Operating System
PAC	-	Programmable Automation Controller
PCB	-	Printed Circuit Board
PID	-	Proportional Integral and Derivative Control
PLC	-	Programmable Logic Controller
PROM	-	Programmable Read Only Memory
RAM	-	Random Access Memory
RDY	-	Ready
RMSS	-	Root Mean Square Summation
RNG	-	Running
ROM	-	Read Only Memory
RTU	-	Remote Telemetry Unit
SPDT	-	Single Pole, Double Throw
ST/SP	-	Start/Stop
TDM	-	Time Division Multiplexing
UPS	-	Uninterruptible Power Supply

- H. To minimize the number of characters in words used in textual descriptions on CRT displays, printouts and nameplates, abbreviations may be used subject to the Engineer's approval. If a specified abbreviation does not exist for a particular word, an abbreviation may be generated using the principles of masking and or vowel deletion. Masking involves retaining the first and last letters in a word and deleting one or more characters (usually vowels) from the interior of the word.

#### 1.06 ENVIRONMENTAL CONDITIONS

- A. Instrumentation equipment and enclosures shall be suitable for ambient conditions specified. All system elements shall operate properly in the presence of telephone lines, power lines, and electrical equipment.
- B. Inside control rooms and climate-controlled electrical rooms, the temperature will normally be 20 to 25 degrees C; relative humidity 40 to 80 percent without condensation and the air will be essentially free of corrosive contaminants and moisture. Appropriate air filtering shall be provided to meet environmental conditions (i.e., for dust).

- C. Other indoor areas may not be air conditioned/heated; temperatures may range between 0 and 40 degrees C with relative humidity between 40 and 95 percent.
- D. Field equipment including instrumentation and panels may be subjected to wind, rain, lightning, and corrosives in the environment, with ambient temperatures from -20 to 40 degrees C and relative humidity from 10 to 100 percent. All supports, brackets, interconnecting hardware, and fasteners shall be aluminum, type 316 stainless steel, or metal alloy as otherwise suitable for chemical resistance within chemical feed/storage areas shown on the installation detail drawings.

**PART 2 -- PRODUCTS**

**2.01 NAMEPLATES**

- A. All items of equipment listed in the instrument schedule, control panels, and all items of digital hardware shall be identified with nameplates. Each nameplate shall be located so that it is readable from the normal observation position and is clearly associated with the device or devices it identifies. Nameplates shall be positioned so that removal of the device for maintenance and repair shall not disturb the nameplate. Nameplates shall include the equipment identification number and description. Abbreviations of the description shall be subject to the Engineer's approval.
- B. Nameplates shall be made of 1/16-inch thick machine engraved laminated phenolic plastic having white numbers and letters not less than 3/16-inch high on a black background.
- C. Nameplates shall be attached to metal equipment by stainless steel screws and to other surfaces by an epoxy-based adhesive that is resistant to oil and moisture. In cases where the label cannot be attached by the above methods, it shall be drilled and attached to the associated device by means of stainless steel wire.

**PART 3 -- EXECUTION**

**3.01 SCHEDULE OF PAYMENT**

- A. Payment to the Contractor for Control and Information System materials, equipment, and labor shall be in accordance with the General and Supplementary Conditions. The schedule of values submitted as required by the General and Supplementary Conditions shall reflect a breakdown of the work required for completion of the Control and Information System. The breakdown shall include sufficient detail to permit the Engineer to administer payment for the Control and Information System as outlined below.
- B. The following payment schedule defines project milestones that will be used for establishing maximum partial payment amounts for the Control and Information System. Payment for field wiring and similar items will be made in addition to the payment for the scopes of services incorporated into the schedule below.

**Task Completed**

**Maximum Cumulative %  
Request for Payment**



Mobilization	10%
Approved Submittals	20%
Hardware Purchase	40%
Loop Checkout	70%
HMI Screens and PLC-8 Start-up and Test	80%
Final Acceptance	100%

- C. Requests for payment for materials and equipment that are not installed on site, but are required for system construction (e.g., digital hardware), or are properly stored as described in the General and Supplementary Conditions and herein, shall be accompanied by invoices from the original supplier to the instrumentation subcontractor substantiating the cost of the materials or equipment.
- D. Any balance remaining within the schedule of values for field instruments and other materials installed on the site, or for other materials for which payment is made by invoice, will be considered due upon completion of the Final Acceptance test.

### 3.02 CLEANING

- A. The Contractor shall thoroughly clean all soiled surfaces of installed equipment and materials.
- B. Upon completion of the instrumentation and control work, the Contractor shall remove all surplus materials, rubbish, and debris that has accumulated during the construction work. The entire area shall be left neat, clean, and acceptable to the CITY.

### 3.03 FINAL ACCEPTANCE

- A. Final acceptance of the Instrumentation, Control and Information System will be determined complete by the Engineer, and shall be based upon the following:
  1. Receipt of acceptable start up completion and availability reports and other documentation as required by the Contract Documents.
  2. Completion of the Availability Demonstration.
  3. Completion of all specified control system training requirements.
  4. Completion of all punch-list items that are significant in the opinion of the Engineer.
- B. Final acceptance of the System shall mark the beginning of the extended warranty period.

- END OF SECTION -

## SECTION 17030 - CONTROL AND INFORMATION SYSTEM SUBMITTALS

### PART 1 -- GENERAL

#### 1.01 THE REQUIREMENT

- A. The Contractor shall submit for review complete Shop Drawings for all equipment in accordance with the General Conditions and Division 1 of the Specifications. All submittal material shall be complete, legible, and reproducible, and shall apply specifically to this project.

#### 1.02 RELATED WORK SPECIFIED ELSEWHERE

- A. Section 01300 – Submittals
- B. Section 17000 – Control and Information System Scope and General Requirements

#### 1.03 DIGITAL HARDWARE SUBMITTALS

- A. Submit system block diagram(s) showing:
  - 1. All equipment to be provided.
  - 2. All interconnecting cable.
  - 3. Equipment names, manufacturer, and model numbers.
  - 4. Equipment locations.
- B. Submit information for all digital equipment including, but not limited to, the following:
  - 1. Bill of materials with equipment names, manufacturers, complete model numbers and locations.
  - 2. Catalog cuts, including complete part number breakdown information.
  - 3. Complete technical, material and environmental specifications.
  - 4. Assembly drawings.
  - 5. Mounting requirements.
  - 6. Color samples.
  - 7. Nameplates.
  - 8. Environmental requirements during storage and operation.

#### 1.04 SOFTWARE SUBMITTALS

A. Software submittals shall include the following as a minimum:

1. Bill of materials with software names, vendors, and complete listings of included software modules.
2. Standard manufacturer's literature describing the products.
3. Description of function of software in Control and Information System.
4. Limitations or constraints of software.
5. Minimum system (processor and memory) requirements.
6. Operation and maintenance requirements.

B. Submit information on the following software:

1. Third-party software, including:
  - a. Operating system.
  - b. Operator workstation (SCADA or HMI) software, including all add-in software provided to perform specific functions (alarm dialers, schedulers, backup creation software, etc.).
  - c. Office-type products, such as spreadsheets, word processors, etc.
  - d. Database management software.
  - e. Communications software, including all applicable local and wide area network software.
  - f. Programmable controller programming software (where applicable).
2. Software configuration, including:
  - a. Graphic display organization.
  - b. Database configuration for operator workstations and database management system.
  - c. Trends.
  - d. System security.
  - e. Formats for all reports, including all required calculations.

- f. Intercommunications between software products required to implement system functions.
- g. Equipment backup configuration and requirements.

#### C. Control Strategies

1. Provide control strategy documentation that includes control strategy diagrams (block oriented logic and ladder logic diagrams, as appropriate) to describe the control of all processes. The written description shall follow the format of the functional control descriptions contained herein. The control strategy submittals shall contain the following as a minimum:
  - a. An overall description of the program structure and how it will meet the specified control requirements.
  - b. A listing of the program.
  - c. Extensive comments in the listings to describe program steps.
  - d. Equation and ladder program derivations for all specified control routines.
  - e. Resource (processor and memory) requirements.
  - f. A listing of inputs and outputs to the control strategy.

#### D. Application Software

1. Provide application software documentation that contains program descriptions for the operation, modification, and maintenance of all application programs provided for the digital system.
2. Application software includes all custom routines developed specifically for this project, or pre-written routines used for accomplishing specified functions for this project. This shall include VBASIC and C programs, and any other add-in custom software.

#### E. Graphic Displays

1. Submit all graphic displays required to perform the control and operator interface functions specified herein.
2. Submit graphic displays for review by the CITY and the Engineer at least 30 days prior to system startup.
3. The Contractor shall allow for one cycle of revisions to the displays prior to system startup. A cycle of revisions shall be defined as all revisions necessary to complete a single set of changes marked by the Engineer. Additional corrections shall be performed during start-up as required to accommodate changes required by actual field conditions, at no additional cost to the CITY.

4. Two of the required submittals in each revision cycle shall be full color prints of the entire set of SCADA HMI displays modified or created under this contract. Additional sets may be in black-and-white or gray-scale.
5. Displays shall be printouts of actual process graphics implemented in the system.

#### 1.05 CONTROL PANEL SUBMITTALS

- A. Submittals shall be provided for all control panels, and shall include:
  1. Exterior panel drawings with front and side views, to scale.
  2. Interior layout drawings showing the locations and sizes of all equipment and wiring mounted within the cabinet, to scale.
  3. Panel area reserved for cable access and conduit entry.
  4. Location plans showing each panel in its assigned location.
- B. Submit information for all exterior and interior panel mounted equipment including, but not limited to, the following:
  1. Bill of materials with equipment names, manufacturers, complete model numbers and locations.
  2. Catalog cuts, including complete part number breakdown information.
  3. Complete technical, material and environmental specifications.
  4. Assembly drawings.
  5. Mounting requirements.
  6. Color samples.
  7. Nameplates.
  8. Environmental requirements during storage and operation.
- C. Submit panel wiring diagrams showing power, signal, and control wiring, including surge protection, relays, courtesy receptacles, lighting, wire size and color coding, etc.

#### 1.06 INSTRUMENT SUBMITTALS

- A. Submit information on all field instruments, including but not limited to the following:
  1. Product (item) name and tag number used herein and on the Contract Drawings.
  2. Catalog cuts, including complete part number breakdown information.

3. Manufacturer's complete model number.
4. Location of the device.
5. Input - output characteristics.
6. Range, size, and graduations.
7. Physical size with dimensions, NEMA enclosure classification and mounting details.
8. Materials of construction of all enclosures, wetted parts and major components.
9. Instrument or control device sizing calculations where applicable.
10. Certified calibration data on all flow metering devices.
11. Environmental requirements during storage and operation.
12. Associated surge protection devices.

#### 1.07 PLC-8 CONTROL PANEL DRAWINGS

- A. The PLC-8 control panel schematics shall be modified or completely redrawn in the latest version of AutoCAD for a complete schematic that includes both the existing input/output wiring and the input/output wiring proposed under this contract. Hand or digitally drawn markups of PDF drawings are not acceptable. The PLC-8 drawings shall be prepared in a neat and legible manner on 11 X 17-inch reproducible prints.

#### 1.08 OPERATION AND MAINTENANCE MANUALS

- A. The Contractor shall deliver equipment operation and maintenance manuals in compliance with Section 01300 - Submittals. Operation and maintenance (O&M) manuals shall consist of two basic parts:
  1. Manufacturer standard O&M manuals for all equipment and software furnished under this Division.
  2. Custom O&M information describing the specific configuration of equipment and software, and the operation and maintenance requirements for this particular project.
- B. The manuals shall contain all illustrations, detailed drawings, wiring diagrams, and instructions necessary for installing, operating, and maintaining the equipment. The illustrated parts shall be numbered for identification. All modifications to manufacturer standard equipment and/or components shall be clearly identified and shown on the drawings and schematics. All information contained therein shall apply specifically to the equipment furnished and shall only include instructions that are applicable. All such

illustrations shall be incorporated within the printing of the page to form a durable and permanent reference book.

- C. The manuals shall be prepared specifically for this installation and shall include all required cuts, drawings, equipment lists, descriptions, etc. that are required to instruct operation and maintenance personnel unfamiliar with such equipment. The maintenance instructions shall include troubleshooting data and full preventive maintenance schedules. The instructions shall be bound in locking 3-D-ring binders with bindings no larger than 3.5 inches. The manuals shall include 15% spare space for the addition of future material. The instructions shall include drawings reduced or folded and shall provide the following as a minimum.
1. A comprehensive index.
  2. A functional description of the entire system, with references to drawings and instructions.
  3. A complete "as-built" set of all approved shop drawings, which shall reflect all work required to achieve final system acceptance.
  4. A complete list of the equipment supplied, including serial numbers, ranges, and pertinent data.
  5. Full specifications on each item.
  6. Detailed service, maintenance, and operation instructions for each item supplied.
  7. Special maintenance requirements particular to this system shall be clearly defined, along with special calibration and test procedures.
  8. Complete parts lists with stock numbers and name, address, and telephone number of the local supplier.
  9. References to manufacturers' standard literature where applicable.
  10. Warning notes shall be located throughout the manual where such notes are required to prevent accidents or inadvertent misuse of equipment.
- D. The operating instructions shall clearly describe the step-by-step procedures that must be followed to implement all phases of all operating modes. The instructions shall be in terms understandable and usable by operating personnel and maintenance crews and shall be useful in the training of such personnel.
- E. The maintenance instructions shall describe the detailed preventive and corrective procedures required, including environmental requirements during equipment storage and system operation, to keep the System in good operating condition. All hardware maintenance documentation shall make reference to appropriate diagnostics, where applicable, and all necessary wiring diagrams, component drawings and PCB schematic drawings shall be included.

- F. The hardware maintenance documentation shall include, as a minimum, the following information:
1. Operation Information - This information shall include a detailed description of how the equipment operates and a block diagram illustrating each major assembly in the equipment.
  2. Preventive-Maintenance Instructions - These instructions shall include all applicable visual examinations, hardware testing and diagnostic routines, and the adjustments necessary for periodic preventive maintenance of the System.
  3. Corrective-Maintenance Instructions - These instructions shall include guides for locating malfunctions down to the card-replacement level. These guides shall include adequate details for quickly and efficiently locating the cause of an equipment malfunction and shall state the probable source(s) of trouble, the symptoms, probable cause, and instructions for remedying the malfunction.
  4. Parts Information - This information shall include the identification of each replaceable or field-repairable component. All parts shall be identified on a list in a drawing; the identification shall be of a level of detail sufficient for procuring any repairable or replaceable part. Cross-references between equipment numbers and manufacturer's part numbers shall be provided.
- G. Software documentation shall conform to a standard format and shall include, but not be limited to, the following:
1. A program abstract that includes:
    - a. Program Name - The symbolic alphanumeric program name.
    - b. Program Title - English text identification.
    - c. Program Synopsis - A brief text shall be provided that specifies the need for the program, states when it shall be used and functionally describes all inputs, outputs and functions performed. This descriptive text shall be written in a language that is understandable by nonsoftware oriented readers.
  2. A program description that shall include, but not be limited to, the following:
    - a. Applicable Documents - List all documents (standard manufacturer's literature, other program descriptions, etc.) by section, if practical, that apply to the program. One complete copy of all applicable reference material shall be provided.
    - b. Input-Output - Identify each input and output parameter, variable, and software element used by the program. State the purpose of all inputs, outputs, and variables.



- c. Processing - This section shall contain a description of the overall structure and function of the program. Describe the program run stream and present a detailed description of how the program operates. Describe the timing and sequencing of operations of the program relative to other programs. Describe all interactions with other programs. Processing logic that is not readily described without considerable background information shall be handled as a special topic with references to an appendix or to control strategy document that details the necessary information. Reference shall also be made to an appendix or control strategy document for equation and program algorithm derivations.
- d. System Configuration - Describe in detail the system configuration or status required for program implementation, if appropriate.
- e. Limitations and Constraints - Summarize all known or anticipated limitations of the program, if appropriate.
- f. Storage - Define program storage requirements in terms of disk or RAM memory allocation.
- g. Verification - Describe, as a minimum, a test that can be used by the operator to assure proper program operation. Define the required system configuration, input requirements and criteria for successful test completion.
- h. Diagnostics - Describe all program diagnostics, where applicable. Descriptions shall list each error statement, indicate clearly what it means, and specify what appropriate actions should be taken.
- i. Malfunction Procedures - Specify procedures to follow for recovering from a malfunction due to either operator error or other sources.

#### 1.10 FINAL SYSTEM DOCUMENTATION

- A. All documentation shall be delivered to the CITY prior to final system acceptance in accordance with the Contract Documents. As a minimum, final documentation shall contain all information originally part of the control system submittals.
- B. If any documentation or other technical information submitted is considered proprietary, such information shall be designated. Documentation or technical information which is designated as being proprietary will be used only for the construction, operation, or maintenance of the System and, to the extent permitted by law, will not be published or otherwise disclosed.
- C. Provide a complete set of detailed electrical interconnection diagrams required to define the complete instrumentation and control system. All diagrams shall be 11 X 17-inch original reproducible prints. All diagrams shall be corrected so as to describe final "as-built" hardware configurations and to reflect the system configuration and control methodology adopted to achieve final system acceptance.

- D. Provide system software documentation for the operation and maintenance of all system software programs provided as a part of the digital system. All system software documentation shall be amended as required to delineate all modifications and to accurately reflect the final as-built software configurations.
- E. Provide application software documentation that contains program descriptions for the operation, modification, and maintenance of all application programs provided for the digital system.
- F. Provide control strategy documentation which shall include control strategy (block oriented or ladder logic) diagrams to describe the control of all processes. Control strategy documentation shall reflect the system configuration and control methodology adopted to achieve final system acceptance. Control strategy documentation shall conform to the submittal requirements listed hereinabove.
- G. O&M documentation shall be amended with all final, adjusted values for all setpoints and other operating parameters for CITY reference.
- H. The CITY recognizes the fact that not all possible problems related to real-time events, software interlocks, and hardware maintenance and utilization can be discovered during the Acceptance Tests. Therefore, the instrumentation subcontractor through the Contractor shall investigate, diagnose, repair, update, and distribute all pertaining documentation of the deficiencies that become evident during the warranty period. All such documentation shall be submitted in writing to the CITY within 30 days of identifying and solving the problem.

#### 1.11 PROGRAMS AND SOURCE LISTINGS

- A. Provide one copy of source listings on DVD media for all custom software written specifically for this facility, all database files configured for this facility, and all control strategies. All source listings shall include a program abstract, program linkage and input/output data. Comments describing the program flow shall be frequently interspersed throughout each listing.

#### 1.12 SUBMITTAL/DOCUMENTATION FORMAT

- A. All drawing-type submittals and documentation shall be rendered and submitted in the latest version of AutoCAD.
- B. All textual-type submittals and documentation shall be rendered and submitted in the latest version of Microsoft Word or in Searchable Adobe Portable Document Format (.pdf).

#### 1.13 ELECTRONIC O&M MANUALS

- A. Subject to acceptance by the CITY and Engineer, the O&M information may be submitted in part or in whole in an electronic format on optical media.
- B. Electronic O&M manuals shall contain information in standard formats (Searchable Adobe PDF, Word, AutoCAD, HTML, etc.) and shall be easily accessible through the use of standard, "off-the-shelf" software such as an Internet browser.

PART 2 -- PRODUCTS

(NOT USED)

PART 3 -- EXECUTION

(NOT USED)

- END OF SECTION -

## SECTION 17040

### CONTROL AND INFORMATION SYSTEM TRAINING REQUIREMENTS

#### PART 1 -- GENERAL

##### 1.01 THE REQUIREMENT

- A. To familiarize the CITY's personnel with the process control system and field instrumentation, training shall be provided as detailed hereunder.

##### 1.02 RELATED WORK SPECIFIED ELSEWHERE

- A. Section 17000 – Control and Information System Scope and General Requirements

##### 1.03 SUBMITTALS

- A. A minimum of 30 days prior to beginning training, submit a detailed training plan describing the following:

1. Course content.
2. Applicability of each course to management, operations, maintenance, laboratory, etc., personnel.
3. Course schedules.
4. Qualifications and experience of individual(s) providing training.

- B. A minimum of 14 days prior to beginning each training course, submit documentation for use by the CITY's personnel during training. The training documentation shall be specific to the particular course, and shall include the following:

1. A listing of all subjects to be covered.
2. Course schedule.
3. Documentation/lesson plans covering all subjects to be covered during the course instruction. Information shall be in a "how to" format, with sufficient background documentation and references to manufacturer literature to provide a thorough and clear understanding of the materials to be covered.

##### 1.04 GENERAL REQUIREMENTS

- A. All costs of providing the training courses shall be borne by the Contractor.

- B. Training courses, especially those for operator training, may be required to be scheduled during non-standard business hours (i.e., not between the hours of 8:00 am and 5:00 pm) to accommodate the working schedule of the CITY's personnel. No additional compensation will be awarded to the Contractor for training at non-standard hours.
- C. All training courses shall complement the experience and skill levels of the CITY's personnel.
- D. Training courses shall be structured in order of increasing capability or security levels. The purpose of this requirement is to allow personnel with lesser training requirements or security password levels to drop out of the training at certain times while the training continues for personnel with greater requirements or higher security levels.
- E. All training courses shall include lecture as well as "hands on" experience for each of the attending personnel. The Contractor shall provide sufficient equipment for this to be accomplished. For example, training in which the instructor uses the computer and the CITY's personnel passively observe as the instructor demonstrates system functions shall not be acceptable.
- F. Unless otherwise specified, all training courses shall be conducted in the CITY's facilities.
- G. All training shall be completed prior to system acceptance.
- H. Standard manufacturer training courses are acceptable pending approval by the Engineer and CITY.

#### 1.05 SCADA SYSTEM SUPERVISOR TRAINING

- A. One half-day (four-hour) session for up to 2 SCADA system supervisors each shall be conducted to provide instruction in the use of the WWTP SCADA System to monitor and control the equipment associated with PLC-8. The training shall include, at a minimum:
  - 1. Detailed discussion of the PLC-8 physical modifications, including all wiring modifications.
  - 2. Detailed discussion of the updated PLC-8 PLC logic.
  - 3. Detailed discussion of the WWTP SCADA HMI screen modifications.
  - 4. Detailed explanation of the clarifier status and alarm signals displayed on the WWTP SCADA HMI and a demonstration of how to test the clarifier overtorque limit switch signals.
  - 5. Detailed explanation of RAS pump operation.
  - 6. Detailed explanation of flow control valve operation.
  - 7. Detailed explanation of Transfer Pump Operation.

## 1.06 MAINTENANCE PERSONEL AND OPERATOR TRAINING

- A. One half-day (four-hour) session for up to 8 persons each shall be conducted to provide instruction in the use of the WWTP SCADA System to monitor and control the equipment associated with PLC-8. The training shall include, at a minimum:
1. Overview of the PLC-8 physical modifications, including all wiring modifications.
  2. Overview of the updated PLC-8 PLC logic.
  3. Overview of the WWTP SCADA HMI screen modifications.
  4. Detailed explanation of the clarifier status and alarm signals displayed on the WWTP SCADA HMI and a demonstration of how to test the clarifier overtorque limit switch signals.
  5. Detailed explanation of RAS pump operation.
  6. Detailed explanation of flow control valve operation.
  7. Detailed explanation of Transfer Pump Operation.
- B. Operators shall be instructed in the names, locations, functions, and basic operation of all items of digital equipment and associated software.
- C. Operator training shall cover process and equipment operation both individually and collectively as an operating system. Normal as well as abnormal operating conditions shall be covered, including the response to failure occurrences and system alarms. All operator/system interactions shall be described.
- D. Operators shall be trained to instruct other operators and shall be provided with all course materials.

## PART 2 -- PRODUCTS

(NOT USED)

## PART 3 -- EXECUTION

(NOT USED)

- END OF SECTION -

## SECTION 17060 - SIGNAL COORDINATION REQUIREMENTS

### PART 1 -- GENERAL

#### 1.01 THE REQUIREMENT

- A. The Contractor shall conform to the signal coordination requirements specified herein.
- B. The Contractor shall be responsible for coordinating signal types and transmission requirements between the various parties providing equipment under this Contract. This shall include, but not be limited to, distribution of appropriate shop drawings among the equipment suppliers, the electrical subcontractor, and the instrumentation subcontractor.
- C. Analog signals shall be signals for transmitting process variables, etc. from instruments and to and from panels, equipment PLC's and Control System PLC's.
- D. Discrete signals shall consist of contact closures or powered signals for transmitting status/alarm information and control commands between starters, panels, equipment PLC's, the Control System, etc.

#### 1.02 ANALOG SIGNAL TRANSMISSION

- A. Signal transmission between electric or electronic instruments, controllers, and all equipment and control devices shall be individually isolated, linear 4-20 milliamperes and shall operate at 24 volts D.C.
- B. Signal output from all transmitters and controllers shall be current regulated and shall not be affected by changes in load resistance within the unit's rating.
- C. All cable shields shall be grounded at one end only, at the control panel, with terminals bonded to the panel ground bus.
- D. Analog signal isolation and/or conversion shall be provided where necessary to interface with instrumentation, equipment controls, panels, and appurtenances.
- E. Non-standard transmission systems such as pulse duration, pulse rate, and voltage regulated shall not be permitted except where specifically noted in the Contract Documents. Where transmitters with nonstandard outputs do occur, their outputs shall be converted to an isolated, linear, 4-20 milliamperes signal.
- F. The Contractor shall provide 24 V power supplies for analog signals and instruments where applicable and as required inside panels, controls, etc.
- G. Where two-wire instruments transmit directly to the Control and Information System, the instrumentation subcontractor shall provide power supplies at the PLC-equipped control panels for those instruments.



- H. Where four-wire instruments with on-board loop power supplies transmit directly to the Control and Information System, the instrumentation subcontractor shall provide necessary signal isolators or shall otherwise isolate the input from the Control and Information System loop power supply. Similar provisions shall be made when a third element such as a recorder, indicator, or single loop controller with integral loop power supply is included in the loop.

#### 1.03 DISCRETE INPUTS

- A. All discrete inputs to equipment and Control and Information System PLC's, from field devices, starters, panels, etc., shall be unpowered (dry) contacts in the field device or equipment, powered from the PLC's, unless specified otherwise.
- B. Sensing power (wetting voltage) supplied by the PLC shall be 24 VDC.

#### 1.04 DISCRETE OUTPUTS

- A. All discrete outputs from local control panels and Control and Information System PLC's to field devices, starters, panels, etc., shall be 24 VDC powered (sourced) from PLC's.
- B. PLC powered discrete outputs shall energize 24 VDC pilot relay coils in the field devices, starters, panels, etc. which in turn open or close contacts in the associated control circuit. The 24 VDC relay coil, contacts, and associated control circuitry shall be furnished integral with the field device, starter, panel, etc. by the supplier and contractor furnishing the field device, starter, or panel.
- C. Where required or specified herein, discrete outputs from equipment and Control and Information System PLC's to field devices, starters, panels, motor operated valves, etc., shall be dry contact or relay outputs.
- D. Outputs to solenoid valves shall be 120 VAC, powered from the PLC or control panel unless specified or shown otherwise.

#### 1.05 OTHER DISCRETE SIGNALS

- A. Discrete signals between starters, panels, etc. where no 24 VDC power supply is available may be 120 VAC, as long as such contacts are clearly identified in the starter, panel, etc. as being powered from a different power supply than other starter/panel components.
- B. Where applicable, warning signs shall be affixed inside the starter, panel, etc. stating that the panel is energized from multiple sources.
- C. Output contacts in the starter, panel, etc., that are powered from other locations shall be provided with special tags and/or color-coding. Disconnecting terminal strips shall be provided for such contacts.
- D. The above requirements shall apply to all starters and panels, regardless of supplier.

## PART 2 -- PRODUCTS

### 2.01 PILOT RELAYS

- A. Pilot relays shall be supplied with the following:
  - 1. 24 VDC or 120 VAC coils, as required.
  - 2. At a minimum, DPDT contacts rated at 5 A, 120 VAC or 28 VDC.
  - 3. Sockets for 24 VDC and 120 VAC relays shall be of different configurations.
  - 4. Clips for attachment to sockets.
  - 5. Indicator lights that glow when the relay coil is powered.
- B. Pilot relays shall be as manufactured by Square D, Allen Bradley, Potter & Brumfield, or equal.

## PART 3 -- EXECUTION

(NOT USED)

- END OF SECTION -

## SECTION 17070 - CONTROL AND INFORMATION SYSTEM TESTING - GENERAL

### PART 1 -- GENERAL

#### 1.01 THE REQUIREMENT

- A. The Contractor shall test the Control and Information System as specified herein to demonstrate compliance with the Contract Documents.

#### 1.02 RELATED WORK SPECIFIED ELSEWHERE

- A. Section 17000 – Control and Information System Scope and General Requirements
- B. Section 17072 – Field Testing

#### 1.03 SUBMITTALS

- A. For each of the specified tests, submit a test plan to the Engineer at least one month in advance of commencement of the tests. The test plan shall contain the following at a minimum:
  - 1. A schedule of all testing to be conducted.
  - 2. A brief description of the testing to be performed
  - 3. Test objectives.
  - 4. Testing criteria per the Specifications.
  - 5. Check lists and procedures for performing each of the specified tests.
  - 6. Sample test result documentation.
  - 7. Requirements for other parties.

#### 1.04 GENERAL REQUIREMENTS

- A. All system start-up and test activities shall follow detailed test procedures; check lists, etc., previously approved by the Engineer. The Engineer shall be notified at least 21 days in advance of any system tests and reserves the right to have his and/or the CITY's representatives in attendance.
- B. The Contractor shall provide the services of experienced factory trained technicians, tools and equipment to field calibrate, test, inspect, and adjust all equipment in accordance with manufacturer's specifications and instructions.
- C. The Contractor (or designee) shall maintain master logbooks for each phase of installation, startup and testing activities specified herein. Each logbook shall include signal, loop or control strategy tag number, equipment identification, description and

space for sign-off dates, Contractor signature and Engineer signature. Example test documentation specific to each phase of testing shall be approved prior to initiation of that testing, as specified hereinabove.

- D. All test data shall be recorded on test forms, previously approved by the Engineer. When each test has been successfully completed, a certified copy of all test results shall be furnished to the Engineer together with a clear and unequivocal statement that all specified test requirements have been met and that the system is operating in accordance with the Contract Documents.
- E. The Engineer will review test documentation in accordance with the Contract Documents and will give written notice of the acceptability of the tests within 10 days of receipt of the test results.

PART 2 -- PRODUCTS

(NOT USED)

PART 3 -- EXECUTION

(NOT USED)

- END OF SECTION -

## SECTION 17072- FIELD TESTING

### PART 1 -- GENERAL

#### 1.01 THE REQUIREMENT

- A. The Contractor shall perform field testing on the Control and Information System as specified herein to demonstrate compliance with the Contract Documents.

#### 1.02 RELATED WORK SPECIFIED ELSEWHERE

- A. Section 17000 – Control and Information System Scope and General Requirements
- B. Section 17070 – Control and Information System Testing, General

#### 1.03 GENERAL REQUIREMENTS

- A. Control system start-up and testing shall be performed to ensure that all plant processes shall be systematically and safely placed under digital control in the following order:
  - 1. Each final control element shall be individually tested as specified hereinafter.
  - 2. Each control loop shall be tested as specified hereinafter.
  - 3. Each control strategy shall be tested under automatic digital control as specified hereinafter.
  - 4. The entire control system shall be tested for overall monitoring, control, communication, and information management functions, and demonstrated for system availability as specified hereinafter.
- B. System start-up and test activities shall include the use of water, if necessary, to establish service conditions that simulate, to the greatest extent possible, normal operating conditions in terms of applied process loads, operating ranges and environmental conditions.
- C. Each phase of testing shall be fully and successfully completed and all associated documentation submitted and approved prior to the next phase being started. Specific exceptions are allowed if written approval has been obtained in advance from the Engineer.

#### 1.04 CONTRACTOR'S RESPONSIBILITIES

- A. The Contractor shall ensure that all mechanical equipment, equipment control panels, local control panels, field instrumentation, control system equipment and related equipment and/or systems are tested for proper installation, adjusted and calibrated on a loop-by-loop basis prior to control system startup to verify that each is ready to function as specified. Each test shall be witnessed, dated and signed off by both the Contractor (or designee) and the Engineer upon satisfactory completion.

- B. The Contractor shall be responsible for coordination of meetings with all affected trades. A meeting shall be held each morning to review the day's test schedule with all affected trades. Similarly, a meeting shall be held each evening to review the day's test results and to review or revise the next day's test schedule as appropriate.
- C. The Contractor shall ensure that the electrical subcontractor conforms to the start-up, test and sign-off procedures specified herein to assure proper function and coordination of all motor control center control and interlock circuitry and the transmission of all discrete and/or analog signals between equipment furnished by the electrical subcontractor and the control system specified herein.

#### 1.05 FINAL CONTROL ELEMENT TESTING

- A. The proper control of all final control elements shall be verified by tests conducted in accordance with the requirements specified herein.
- B. All modulating final control elements shall be tested for appropriate speed or position response by applying power and input demand signals, and observing the equipment for proper direction and level of reaction. Each final control element shall be tested at 0, 25, 50, 75, and 100 percent of signal input level and the results checked against specified accuracy tolerances. Final control elements, such as VFD's, that require turndown limits shall be initially set during this test.
- C. All non-modulating final control elements shall be tested for appropriate position response by applying and simulating control signals, and observing the equipment for proper reaction.

#### 1.06 LOOP CHECKOUT

- A. Prior to control system startup and testing, each monitoring and control loop shall be tested on an individual basis from the primary element to the final element, including the operator workstation or loop controller level, for continuity and for proper operation and calibration.
- B. Signals from transducers, sensors, and transmitters shall be utilized to verify control responses. Simulated input data signals may be used subject to prior written approval by the Engineer. All modes of control shall be exercised and checked for proper operation.
- C. The accuracy of all DAC's shall be verified by manually entering engineering unit data values at the operator workstation and then reading and recording the resulting analog output data.
- D. The accuracy of all ADC's shall be verified using field inputs or by manually applying input signals at the final controller, and then reading and recording the resulting analog input data at the operator workstation.

- E. Each loop tested shall be witnessed, dated and signed off by both the Contractor (or designee) and the Engineer upon satisfactory completion. Contractor shall coordinate with the Engineer for witness testing.

#### 1.07 CONTROL SYSTEM STARTUP AND TESTING

- A. Control system startup and testing shall be performed to demonstrate complete compliance with all specified functional and operational requirements. Testing activities shall include the simulation of both normal and abnormal operating conditions.
- B. Testing shall include all equipment monitored by PLC-8 and shall include at a minimum the following:
  - 1. Clarifier No. 3.
  - 2. RAS Pump Nos. 4, 5, and 6
  - 3. Transfer Pumps
  - 4. All flow meters.
  - 5. All flow control valves.
- C. All digital hardware shall be fully inspected and tested for function, operation and continuity of circuits. All diagnostic programs shall be run to verify the proper operation of all digital equipment.
- D. Final control elements and ancillary equipment shall be tested under start-up and steady-state operating conditions to verify that proper and stable control is achieved using local area control panels, motor control center circuits, and local field mounted control circuits. All hardwired control circuit interlocks and alarms shall be operational. The control to final control elements and ancillary equipment shall be tested using both manual and automatic (where provided) control circuits.
- E. Signals from transducers, sensors, and transmitters shall be utilized to verify control responses for final control elements. Simulated input data signals may be used subject to prior written approval by the Engineer.
- F. Each control strategy shall be tested to verify the proper operation of all required functions. The control system start-up and test activities shall include procedures for tuning all control loops incorporating PID control modules, and for adjusting and testing all control loops as required to verify specified performance.
- G. The control system start-up and test activities shall include running tests to prove that the Instrumentation, Control and Information System is capable of continuously, safely and reliably regulating processes, as required by the Contract, under service conditions that simulate, to the greatest extent possible, normal plant operating ranges and environmental conditions.
- H. A witnessed functional acceptance test shall be performed to demonstrate satisfactory performance of individual monitoring and control loops and control strategies. At least one test shall be performed to verify that the control and instrumentation system is capable of simultaneously implementing all specified operations.

- I. Each loop and control strategy test shall be witnessed and signed off by both the Contractor (or designee) and the Engineer upon satisfactory completion.

#### 1.08 FACILITY STARTUP COORDINATION

- A. Facility start-up shall comply with requirements specified in the Contract Documents and those requirements specified herein. Facility start-up shall commence after all previously described start-up and test activities have been successfully completed and shall demonstrate that the Instrumentation, Control and Information System can meet all Contract requirements with equipment operating over full operating ranges under actual operating conditions.
- B. The control system start-up period shall be coordinated with process startup activities and shall be extended as required until all plant processes are fully operational and to satisfy the Engineer that all control system Contract requirements have been fulfilled in accordance with the Contract Documents.
- C. The instrumentation subcontractor's personnel shall be available to provide both on-site, full-time (eight hours/day, five days/week) and 24 hours on-call (seven days/week) support of operating and maintenance activities for the duration of the start-up period.
- D. At least one qualified control systems technician shall be provided for control system startup and test activities (at least two when loop checkout is being performed).

#### PART 2 -- PRODUCTS

(NOT USED)

#### PART 3 -- EXECUTION

(NOT USED)

- END OF SECTION -



## SECTION 17080 - QUALITY ASSURANCE

### PART 1 -- GENERAL

#### 1.01 THE REQUIREMENT

- A. It is the intent of these Specifications and Drawings to secure high quality in all materials, equipment and workmanship in order to facilitate operations and maintenance of the facility. The Contractor shall provide equipment and services to meet this intent.

#### 1.02 REFERENCE SPECIFICATIONS, CODES AND STANDARDS

- A. All work shall be installed in accordance with the National Electric Code, National Electric Safety Code, OSHA, State, local and other applicable codes.

#### 1.03 QUALITY ASSURANCE - GENERAL

- A. All equipment and materials shall be new and the products of reputable recognized suppliers having adequate experience in the manufacture of these particular items.
- B. For uniformity, only one manufacturer will be accepted for each type of product.
- C. All equipment shall be designed for the service intended and shall be of rugged construction, of ample strength for all stresses that may occur during fabrication, transportation, and erection as well as during continuous or intermittent operation. They shall be adequately stayed, braced and anchored and shall be installed in a neat and workmanlike manner. Appearance and safety, as well as utility, shall be given consideration in the design of details.
- D. All components and devices installed shall be standard items of industrial grade, unless otherwise noted, which shall be of sturdy and durable construction and be suitable for long, trouble-free service.
- E. Electronic components shall be de-rated to assure dependability and long-term stability.
- F. Printed circuit boards in field mounted equipment shall be suitable for the specified environmental conditions.
- G. Alignment and adjustments shall be non-critical, stable with temperature changes or aging and accomplished with premium grade potentiometers.
- H. Components of specially selected values shall not be inserted into standard electronic assemblies in order to meet the performance requirements of this specification.

## 1.05 OPTIONAL EQUIPMENT

- A. Optional or substituted equipment or both requiring changes in details or dimensions required to maintain all structural, mechanical, electrical, control, operating, maintenance or design features incorporated in these Specifications and Drawings shall be made at no additional cost to the CITY. In the event that the changes are necessary, calculations and drawings showing the proposed revisions shall be submitted for approval. The Contractor shall coordinate all changes with other affected trades and contracts and pay all additional charges incurred.

## 1.06 GUARANTEE

- A. The instrumentation subcontractor through the Contractor shall install, maintain and guarantee the Instrumentation, Control and Information System as specified under the General Conditions and Division 1 of the Specifications. Maintenance personnel provided by the instrumentation subcontractor shall instruct the CITY's personnel in the operation, adjustment, calibration and repair of the equipment being serviced. All preventive and corrective activities shall be documented with service reports, which shall identify the equipment being serviced, state the condition of the equipment, describe all work performed and list materials used. A copy of all service reports shall be delivered to the CITY on the day the work is performed.
- B. The instrumentation subcontractor shall provide the services of factory-trained service technician(s) at least twice during the guarantee period, for the purpose of performing preventive hardware maintenance.
- C. Corrective hardware and software maintenance during the guarantee period shall be performed in accordance with the requirements of Division 1 and, in addition, shall meet the following requirements:
  - 1. Corrective hardware maintenance shall be performed by factory-trained service technician(s) specifically trained to service the digital equipment provided. Technicians possessing suitable training and experience shall be provided to perform corrective maintenance on all other equipment. The hardware service technician(s) shall be available on-site within 24 working hours after notification by the CITY.
  - 2. Corrective software maintenance shall be performed for software provided by the instrumentation subcontractor and incorporated into the system prior to the completion of system commissioning. Software service programmer(s) shall be available for consultation within four business hours and, if required, on-site within 16 business hours after notification by the CITY. Corrective software maintenance shall include the supply, installation and startup of all application software upgrades released during the guarantee period.
  - 3. Corrective hardware and software maintenance performed during the guarantee period shall be performed at no cost to the CITY.
  - 4. As used herein, the term "working hours" shall be defined as those of the treatment facility (seven days per week, 24 hours per day). The term "business

hours" shall be defined as the hours between 8:00 a.m. and 5:00 p.m., local time, Monday through Friday; excluding holidays.

5. The guarantee period shall commence upon final acceptance of the completed treatment facility in accordance with the provisions of the Contract Documents.
- D. The instrumentation subcontractor shall submit to the CITY a proposed maintenance agreement incorporating the following features:
1. Extension of preventive hardware maintenance services as described above for a period of up to five years from the expiration of the warranty period.
  2. Provisions for corrective hardware and/or software maintenance work on a will-call basis for a period of up to five years from the expiration of the warranty period. Corrective maintenance work shall be performed by properly trained personnel as described above.
- E. The proposed agreement shall include provisions for payment based upon an annual fee for preventive maintenance and cost plus expenses for corrective maintenance work. The portion dealing with corrective maintenance shall be written to include corrective maintenance caused by actions of the CITY during the warranty period and shall contain clauses for re-negotiation of contract prices based upon changes in recognized economic indicators published by the United States Department of Commerce.

#### 1.07 SHIPPING HANDLING AND STORAGE

- A. In addition to shipping, handling and storage requirements specified elsewhere in the Contract Documents, air conditioning/heating shall be provided for storage of all field instrumentation, panels, digital equipment and ancillary devices to maintain temperatures between 20 and 25 degrees C and relative humidity 40 to 60 percent without condensation. The air shall be filtered and free of corrosive contaminants and moisture.

#### 1.08 FABRICATION

- A. Fabrication of all equipment shall conform to the codes and standards outlined in this Section, and other portions of the Contract Documents.

#### 1.09 INSTALLATION

- A. All instrumentation and control system installation work, whether new construction or modifications to existing equipment/panels/structures, shall conform to the codes and standards outlined in this Section, and other portions of the Contract Documents.
- B. The instrumentation subcontractor shall assign a competent representative who shall provide full time coordination and supervision of all on-site instrumentation and control system construction work from commencement of construction through completion and final acceptance.

- C. All labor shall be performed by qualified craftsmen in accordance with the standards of workmanship in their profession and shall have had a minimum of three years of documented experience on similar projects.
- D. All equipment and materials shall fit properly in their installations. Any required work to correct improperly fit installations shall be performed at no additional expense to the CITY.
- E. All work shall be performed in a neat and workmanlike manner. All hardware and instrumentation shall be installed in accordance with requirements specified herein, in accordance with industry best practices, in accordance with manufacturers' recommendations, and in a manner suitable for ease of operation, inspection, and maintenance. All wiring shall be neatly bundled, run in wireway, and terminated. All spare wiring shall be neatly coiled and clearly labeled at both ends for future use by the CITY. Any work not meeting these requirements shall be corrected at no expense to the CITY.
- F. Sufficient common-mode and differential-mode noise rejection shall be provided to insure operation of the plant process control system to meet all specification requirements. General practice shall include:
  - 1. Maintaining crossings between noisy wires and signal wires at right angles.
  - 2. Maintaining separation between noisy wires and signal wires as wide as practical.
  - 3. Grounding all signals, shields and power supplies at the process control unit or local control panel.
  - 4. Providing passive filters on signals with time constant compatible with scan intervals and overvoltage protection.
  - 5. Eliminating cable splices. All splices in instrumentation and control system signal and network cables shall be approved in advance by the Engineer.
  - 6. Providing a floating output for transmitters that have their own power sources.
- G. DC and AC power grounding shall be performed in accordance with the digital hardware manufacturer's recommendations as well as all applicable code requirements.
- H. The case of each field instrument and control panel shall be grounded in compliance with the National Electric Code.

Power wires shall be separated from parallel-running signal wires by the following minimum spacing:

<u>CIRCUIT VOLTAGE (VAC)</u>	<u>MINIMUM SPACING (IN.)</u>
120	12
240	18
480	18
2000 and above	24

- I. The Contractor shall provide all required cutting, drilling, inserts, supports, bolts, and anchors, and shall securely attach all equipment and materials to their supports. Embedded supports for equipment furnished under this Division shall be provided and installed as shown specified herein and shown on the Drawings.
- J. Digital system equipment items shall not be installed, however, until all architectural, mechanical and electrical work has been completed in the equipment rooms, MCC's, control rooms and all structural and/or mechanical work has been completed within 50 feet of equipment locations.
- K. Upon completion of the above construction work, the Contractor shall request an inspection of the above-named areas. The Engineer will issue a written approval to proceed with delivery and installation only after being satisfied that all work described above has been properly performed. Digital equipment shall remain at the factory site or storage prior to approval for delivery to the project site. Partial shipments may be required to meet construction schedule requirements.

PART 2 -- PRODUCTS

(NOT USED)

PART 3 -- EXECUTION

(NOT USED)

- END OF SECTION -

## SECTION 17300 – MISCELLANEOUS MODIFICATIONS

### PART 1 -- GENERAL

#### 1.01 THE REQUIREMENT

- A. The CONTRACTOR shall furnish, test, install and place in satisfactory operation the miscellaneous modifications described herein together with all programming work, spare parts, accessories, and appurtenances as specified herein or required for a complete and operating system.
- B. All hardware, software, programming, testing and startup services together with all necessary accessories such as power supplies, conditioning equipment, mounting hardware, signal input and output terminal blocks, and plug strips which may be required to complete the work shall be provided.

#### 1.02 RELATED WORK SPECIFIED ELSEWHERE

- A. Section 17000 - Control and Information System Scope and General Requirements
- B. Section 17560 - Transient Voltage Surge Suppression Devices
- C. Refer to Division 16 for additional requirements for cable, circuit breakers, disconnect switches, etc.

#### 1.03 GENERAL INFORMATION AND DESCRIPTION

- A. These Specifications are intended to give a general description of what is required, but do not cover all details which will vary in accordance with the requirements of the equipment furnished. They are, however, intended to cover the furnishing, delivery and complete installation and field testing, of all materials, equipment and appurtenances for complete systems herein specified, whether specifically mentioned in the Specification or not.
- B. For all units there shall be furnished and installed all necessary and desirable accessory equipment and auxiliaries whether specifically mentioned in these Specifications or not. This installation shall incorporate the highest standards for the type of service shown on the Drawings including field testing of the entire installation and instruction of operating personnel in the care, operation, and maintenance of all equipment.
- C. All equipment shall be of first class work quality and shall be entirely designed and suitable for the intended services. All materials used in fabricating the equipment shall be new and undamaged.
- D. All equipment of each type, i.e., all controllers, all indicators, all relays, all surge protectors, all signal converters, etc., provided under this Contract shall be furnished by a single manufacturer.

- E. Due consideration shall be given to installation requirements for enclosures in new and existing structures. The CONTRACTOR shall examine plans and/or field inspect new and existing structures as required to determine installation requirements, and shall coordinate the installation of all enclosures with the COUNTY and all affected CONTRACTORS. The CONTRACTOR shall be responsible for all costs associated with installation of enclosures, including repair of damage to structures (incidental, accidental or unavoidable).

## PART 2 -- PRODUCTS

### 2.01 PLC-8 Logic Program Replacement

- A. The existing PLC-8 hardware and software has been migrated from a Simax 400 PLC to a Schneider Electric Unity PLC hardware and software platform. The existing PLC-8 logic program was generated by converting the original Simax 400 PLC logic to Schneider Electric Unity Pro XL V8.0 - 131118 using 3<sup>rd</sup> party conversion software. The result of the conversion is PLC logic with no documentation that is difficult to modify.
- B. A complete PLC-8 replacement logic program shall be developed, deployed, tested, started up and finalized by the instrumentation subcontractor. Replacement of the PLC software shall require careful planning and implementation to ensure that logic is compatible with the existing WWTP SCADA System. The PLC-8 logic shall be fully documented with a clear, concise functional description of each ladder logic segment or function block.
- C. The PLC-8 logic program shall perform the control strategies described Section 17950 and incorporate all of the equipment and instruments listed in Section 17920 Input Output List and shown on the Instrumentation Drawings and Electrical Drawings. The PLC-8 logic shall include, but is not limited to the following:
  - a. Clarifier No. 3.
  - b. RAS Pump Nos. 4, 5, and 6.
  - c. Transfer Pumps
  - d. Flow to Clarifier Control Valves
  - e. Distribution Wetwell Level.
  - f. RAS Pump Station No. 2 WAS Flow Control Valve.
  - g. Clarifier No. 3 Flow Meters.
  - h. RAS PS No. 2 WAS Flow Meters.
  - i. Clarifier No. 3 WAS Flow Meter.
  - j. RAS to Train Loop Flow Meters.
- D. The instrumentation subcontractor shall notify the Engineer and the CITY 30 days prior to updating the PLC-8 logic program and shall take steps to ensure minimal disruption of WWTP operations.
- E. The PLC software used to develop the PLC-8 logic shall be Unity Pro XL V8.0 - 131118 by Schneider Electric. The instrumentation subcontractor shall be responsible for providing a PLC software development license for the instrumentation subcontractors use for the duration of the project at no cost to the CITY.

## 2.02 WWTP SCADA HMI Modifications

- A. The existing WWTP SCADA HMI software platform is Proficy HMI/SCADA - iFIX Version 5.5 (build 8120) and the same software version shall be utilized to make any HMI modifications.
- B. The existing WWTP SCADA HMI screens shall be modified to include the additional status and alarm signals for Clarifier No. 3, shown on the P&ID Drawings and listed in Section 17920, and as required to support the PLC-8 software replacement. Clarifier No. 3 shall be added to the "WWTP Clarifiers" HMI screen and the functionality shall match that of the existing clarifier graphics displayed on the screen.
- C. Configure the SCADA historian/alarm server and report generation software to support the PLC-8 software replacement, as required. Include the status and alarm signals for Clarifier No. 3.
- D. All modifications shall adhere to the CITY's SCADA HMI graphics standards and shall maintain the "look and feel" of the existing GE iFix HMI screens.
- E. The instrumentation subcontractor shall notify the Engineer and the CITY 30 days prior to performing SCADA HMI modifications and take steps to ensure minimal disruption of WWTP operations.

## 2.03 PLC-8 Control Panel Modifications

- A. The existing PLC-8 spare digital (discrete) inputs shall be utilized for Clarifier No. 3 status and alarm signals. Provide all terminal blocks, fuses, DIN rails, signal surge suppression devices and materials required to terminate the signals in the PLC-8 control panel. Surge suppression devices shall meet the requirements of Section 17560.
- B. All signal wiring shall be routed, terminated and labeled in accordance with Section 17500.

## 2.04 Documentation

- A. Instrumentation subcontractor shall submit the modified PLC-8 logic program to the Engineer and CITY's ICE Department at the completion of the project.
- B. CITY shall provide all available existing PLC-8 documentation to the instrumentation subcontractor upon request.
- C. Instrumentation subcontractor shall modify the existing PLC-8 control panel schematic to reflect the modifications performed under this contract or create a new complete .dwg schematic of the PLC-8 control panel in the latest version of AutoCAD. The final PLC-8 control panel schematic shall be submitted to the CITY in AutoCAD .dwg format. Refer to Section 17030 for additional requirements.



PART 3 -- EXECUTION

3.01 INSTALLATION

- A. Refer to Section 17000.

- END OF SECTION -

## SECTION 17560 - TRANSIENT VOLTAGE SURGE SUPPRESSION DEVICES

### PART 1 -- GENERAL

#### 1.01 THE REQUIREMENT

- A. The CONTRACTOR shall furnish, install and place in satisfactory operation the transient voltage surge suppression (TVSS) devices as specified herein and as shown on the Drawings.

#### 1.02 RELATED WORK SPECIFIED ELSEWHERE

- A. Section 17000 – Control and Information System Scope and General Requirements

#### 1.03 GENERAL INFORMATION AND DESCRIPTION

- A. All surge protectors of each type provided under this Contract shall be furnished by a single manufacturer.

#### 1.04 TOOLS, SUPPLIES AND SPARE PARTS

- A. The following specific spare parts items shall be provided:
  - 1. Two of each type of transient voltage surge suppression (TVSS) devices provided under this Contract.

### PART 2 -- PRODUCTS

#### 2.01 ELECTRICAL TRANSIENT PROTECTION, GENERAL

- A. All electrical and electronic elements shall be protected against damage due to electrical transients induced in interconnecting lines from lightning discharges and nearby electrical systems.
- B. Manufacturer's Requirements: All transient voltage surge suppressor devices shall be multi stage serial devices manufactured by a company that has been engaged in the design, development, and manufacture of such devices for at least 5 years. Acceptable manufacturers shall be Phoenix Contact, Edco, Transtector, or equal.
- C. Surge protection device installations shall comply with UL 94, the National Electric Code (NEC), and all applicable local codes.
- D. Surge protection devices shall be installed as close to the equipment to be protected as practically possible.
- E. Suppressor Locations: As a minimum, provide surge suppressors at the following locations:

1. At all connections between AC power, DC power and associated electrical and electronic equipment, including panels, cabinets, rack assemblies, and field mounted powered instruments.
  2. At both ends of all two-wire analog signal circuits and all four wire analog power/signal circuits.
  3. At the panel end of all 24 VDC or 120 VAC discrete input (dry contact) and discrete output circuits.
  4. At each device termination point of copper-based communication cables (e.g., serial, parallel, Ethernet, Device Net, etc.).
  5. On all telephone communications lines.
  6. RF antenna cable radio terminus.
- F. All indoor and outdoor panels, racks and enclosures shall contain multi-stage surge suppression devices which shall be integral with the terminal block assembly as a complete surge protection system. Systems shall be DIN rail mounted of modular design for field replacement without the need to remove terminated wiring. System shall be Phoenix Contact PLUGTRAB series, or equal.
- G. Surge protectors shall be as follows:
1. 120-Volt field mounted analog transmitter. The protector shall combine AC power protection and 4-20 mA signal line protection. The suppressor shall be ASCO Model 265 or equal.
  2. Field mounted 120-Volt power surge suppressor shall be ASCO Model 252 or equal.
  3. Field mounted 480-Volt power surge suppressor for 3PH system shall be SDSA 3650 from SQD or equal.
  4. Panel mounted 120-volt power surge suppression shall be Phoenix PLUGTRAB, or equal.
  5. Two and four wire 4-20 mA analog signal line and power protection at the panel side shall be Phoenix PLUGTRAB, or equal.
  6. Field mounted two and four wire field mounted 4-20 mA analog signal line and power protection shall be JOSLYN model 1669-06, Edco, or equal.
  7. Two wire discrete input/output signal line protection at the panel side shall be Phoenix PLUGTRAB, or equal.
  8. Non-fiber optic data networks (serial, parallel, Ethernet, Profibus, Device Net telephone, etc.) shall include signal line protection at each device termination point. Phoenix PLUGTRAB, or equal.

## 2.02 AC POWER PROTECTION CHARACTERISTICS

- A. Surge suppressor assemblies for connections to AC power supply circuits shall be assemblies that:
1. Are constructed as multistage devices Consisting of gas tube arrestors, high energy metal oxide varistors, or silicon avalanche suppression diodes. Suppressor assemblies shall automatically recover from surge events.
  2. Comply with all requirements of UL 1449, second edition and meet or exceed the following performance criteria based on a test surge wave shape with an 8-microsecond rise time and a 20-microsecond exponential decay time:
    - a. Minimum Operating Voltage: 130V ac
    - b. Maximum Breakdown Voltage: 150V ac
    - c. Maximum Operating Current: 15 amps
    - d. Peak First Stage Surge Current: 20,000 amps
    - e. Maximum First Stage Clamping Voltage: 350 volts
    - f. Maximum Second Stage Clamping Voltage: 210 volts
    - g. Ambient Temperature Range: -20 degrees C to +85 degrees C

## 2.03 ANALOG SIGNAL CIRCUIT PROTECTION CHARACTERISTICS

- A. Surge suppressors for analog signal circuits shall:
1. Limit line-to-ground and line-to-line voltage to 33 volts on 24V dc circuits.
  2. Meet or exceed the following performance criteria based on a test surge wave with 8-microsecond rise time and 20-microsecond exponential decay time:
    - a. Recovery: Automatic
    - b. Peak Source Current: 10,000 amps
    - c. Pulse Lift Before Failure: 100 occurrences
    - d. Minimum Voltage Clamp Rating: 33 volts
    - e. Series Impedance: 24 ohms total
    - f. Temperature Range: -20 degrees C to +85 degrees C
    - g. Operating Voltage: Less than 30V dc
    - h. Operating Current: 4 to 20 mA dc
    - i. Resistance Line-to-Ground: Greater than 1 megohm

## 2.04 DISCRETE SIGNAL CIRCUIT PROTECTION CHARACTERISTICS

- A. Surge suppressors for analog signal circuits shall:
1. Limit line-to-ground and line-to-line voltage to 60 volts on 24V dc circuits.
  2. Meet or exceed the following performance criteria based on a test surge wave with 8-microsecond rise time and 20-microsecond exponential decay time:
    - a. Recovery: Automatic

- b. Peak Source Current: 10,000 amps
- c. Pulse Lift Before Failure: 100 occurrences
- d. Minimum Voltage Clamp Rating: 60 volts
- e. Series Impedance: 15 ohms total
- f. Temperature Range: -40 degrees C to +85 degrees C
- g. Resistance Line-to-Ground: Greater than 1 megohm

## 2.05 COMMUNICATION CIRCUIT PROTECTION CHARACTERISTICS

### A. Surge suppressors for copper-based data communication circuits shall:

- 1. Be designed for the specific data communication media and protocol to be protected (e.g., telephone, serial, parallel, Ethernet, DeviceNet, coax, twinaxial, twisted pair, RF, etc.).
- 2. Provide protection of equipment to within the equipment's surge withstand levels for applicable standard test wave forms of the following standards:
  - a. IEC 60-1 / DIN VDE 0432 part 2
  - b. CCITT K17 / DIN VDE 0845 part 2
  - c. IEEE C62.31
- 3. Provide automatic recovery.

## PART 3 -- EXECUTION

### 3.01 REQUIREMENTS

- A. Install in accordance with manufacture recommended practices and applicable codes.
- B. Refer to Section 17500 for additional requirements.

- END OF SECTION -

**TABLE 17910  
INSTRUMENT SCHEDULE**

TAG	DESCRIPTION	SERVICE	RANGE/ SETPOINT	SIZE	SECTION	P&ID	NOTES
NSHH-22437	CLARIFIER NO. 3 RAKE DRIVE	HIGH HIGH TORQUE CUT-OUT			17950	I-2	
NSH-22437	CLARIFIER NO. 3 RAKE DRIVE	HIGH TORQUE			17950	I-2	
ZS-22533	CLARIFIER NO. 3 RAKE DRIVE	POSITION			17950	I-2	
ZS-22534	CLARIFIER NO. 3 RAKE DRIVE	POSITION			17950	I-2	

17910 09/30/2022 09:17:04

TABLE 17910 - 1

## SECTION 17920 - CONTROL SYSTEM INPUT/OUTPUT SCHEDULE

### PART 1 -- GENERAL

#### 1.01 THE REQUIREMENT

- A. The Contractor shall furnish, test, install and place in satisfactory operation all control system inputs and outputs as herein specified and as shown on the Drawings.

#### 1.02 RELATED WORK SPECIFIED ELSEWHERE

- A. Section 17900 – Schedules and Control Descriptions

### PART 2 -- CONTROL SYSTEM INPUT / OUTPUT SCHEDULE

See attached I/O Schedule.

#### 2.01 DEFINITIONS

##### 1. Physical Input/Output types are as follows:

DI	-	Discrete Input
DO	-	Discrete Output
AI	-	Analog Input
AO	-	Analog Output

##### 2. Virtual (Electronic) Input/Output types are as follows:

DDI	-	Digital Discrete Input
DDO	-	Digital Discrete Output
DAI	-	Digital Analog Input
DAO	-	Digital Analog Output

**TABLE 17920**  
**INPUT/OUTPUT SCHEDULE**

TAG	SERVICE DESCRIPTION	FUNCTION	PLC	I/O TYPE	P&ID	NOTES
NAHH-22434	CLARIFIER NO. 3 RAKE DRIVE	HIGH-HIGH TORQUE CUT-OUT	PLC-8	DI	I-2	
NAH-22437	CLARIFIER NO. 3 RAKE DRIVE	HIGH TORQUE ALARM	PLC-8	DI	I-2	
YLR-22437	CLARIFIER NO. 3 RAKE DRIVE	MOTOR OVERLOAD	PLC-8	DI	I-2	
YA-22435	CLARIFIER NO. 3 RAKE DRIVE	RUNNING	PLC-8	DI	I-2	

17920 09/30/2022 09:14:32

TABLE 17920 - 1



## SECTION 17950

### FUNCTIONAL CONTROL DESCRIPTIONS

#### PART 1 -- GENERAL

##### 1.01 THE REQUIREMENT

- A. The Contractor shall furnish, test, install and place in satisfactory operation all equipment as herein specified and as shown on the Drawings. The Contractor shall be responsible for furnishing complete functioning systems as described herein.
- B. Together with the control system input/output schedule, the equipment specifications (including functional descriptions for local equipment control panels), and the Drawings, the functional control descriptions describe the required operation, monitoring, and control of the facilities included in this Contract.
- C. The functional descriptions contain requirements for furnishing and installing labor and materials that may not appear elsewhere in the Contract Documents.
- D. All equipment and services required in equipment local control panels provided to implement the monitoring and control functions described herein or in the process input/output schedules shall be provided by the Contractor through individual equipment suppliers.
- E. Unless specifically stated otherwise, all interconnected wiring between all instruments, panels, controls, and other devices listed in the functional descriptions as required to provide all functions specified herein shall be furnished by the electrical subcontractor under Division 16. The electrical subcontractor shall provide all cable and conduit required to carry all signals listed in the process input/output schedules. Special cables that are required for interconnection between sensors or probes and transmitters or signal conditioners shall be furnished with the instrumentation devices by the equipment supplier.

##### 1.02 RELATED WORK SPECIFIED ELSEWHERE

- A. Section 01520 – Maintenance of Utility Operations During Construction
- B. Section 17920 – Control System Input/Output Schedule

#### PART 2 -- FUNCTIONAL CONTROL DESCRIPTIONS, GENERAL

##### 2.01 DEFINITIONS

- A. RUNNING status signals shall be from auxiliary contacts provided with the motor control equipment (i.e., starter, VFD, SCR, etc.).

- B. AUTO status signals shall be defined as HAND-OFF-AUTO switch in the AUTO position or process control system in AUTO (versus MANUAL).
- C. FAIL status signals shall be defined as motor overload and/or any other shut down mode such as overtorque, overtemperature, low oil pressure, high vibration, etc.
- D. READY status signal shall be defined as all conditions, including equipment control power, satisfied to permit remote control of the equipment.

## 2.02 CONVENTIONS

- A. Operator workstation graphic display symbols and indicator lights on all MCC's, control panels, starter enclosures, etc. shall conform to the following color convention:

<u>Condition</u>	<u>Color</u>
Running/On/Open	Red
Auto/Ready	White
Stopped/Off/Closed	Green
Fail/Alarm	Amber
Generic Status	Blue or White

## 2.03 PROCESS CONTROL

- A. Where setpoints, operating limits, and other control settings are provided by the functional descriptions, these settings shall be initial settings only and shall be used for assistance in the initial startup of the plant. All such settings shall be fully adjustable and, based on actual operating conditions, the instrumentation subcontractor shall make all necessary adjustments to provide smooth, stable operation at no additional cost to the Owner.
- B. Provision shall be made in PLC logic to suppress nuisance alarms and control actions by the following means:
  1. For alarms and control actions derived from analog input signals, use adjustable time delays and deadbands.
  2. For alarms and control actions derived from discrete input signals, use adjustable time delays.
  3. Initial settings for time delays shall be 10 seconds (range 0-120 seconds). Initial settings for deadbands shall be 5% of span (range 0-100%).
  4. Equipment that is started or stopped manually by the operator shall start or stop immediately, with no time delay.
- C. All setpoint control shall be by PID control algorithms. Where only proportional control is specified, tuning constants shall be used to reduce the Integral and Derivative functions to zero. All setpoints, sequence times, sequence orders, dead bands, PID tuning

parameters, PLC delay timers, variable speed operating range limits, and similar control constants shall be accessible and alterable from the operator workstations.

- D. Unless otherwise specified, all equipment shall automatically restart after a power failure utilizing adjustable start delay timers in PLC control logic. Unless otherwise specified, all PLC control strategies shall be based upon automatic restart after a power failure and shall return to a normal control mode upon restoration of power.
- E. The PLC shall be capable of receiving initial run-time values for existing and proposed equipment. Initial run-time shall not automatically be assumed to be zero.
- F. A control discrepancy alarm shall be generated through the PLC for any drive, motor, etc. for which a command has been issued, but for which the PLC is not receiving a confirming status signal (e.g., start command with no run feedback). The failure shall be logged.
- G. An instrument failure alarm shall be generated for any instrument which is generating a signal that is less than 4 mA or greater than 20 mA.
- H. Unless otherwise specified in an individual control description, an instrument failure or control discrepancy alarm shall cause the control strategy to maintain last values and to generate an alarm. Manual initiation of the automatic control strategy shall be required.
- I. A control program that controls multiple pieces of equipment shall not be prevented from running because not all of the equipment is in AUTO. If equipment within an equipment chain is required to be running for program operation and it is running in HAND or MANUAL, then the program shall run and control the other equipment that is in AUTO.
- J. All PLC wait states (internal time delays, etc.) after an operator action shall be displayed on the operator workstation.

### PART 3 -- FUNCTIONAL CONTROL DESCRIPTIONS

The WWTP SCADA HMI screens shall be referred to as the "HMI" for the remainder of this specification.

#### 3.01 CLARIFIERS

- A. Clarifiers No. 3 panel status signals shall be wired to PLC-8 for remote status monitoring from the HMI. This work shall include adding a Clarifier No. 3 graphic to the "WWTP Clarifiers" overview screen. The Clarifier Overview Screen shall be modified in accordance with the City's standards. Refer to Section 17300 for more information.
- B. Control Operation
  - 1. Local control and local status indication shall be provided by the clarifier system supplier as specified in section 11232 including but not limited to the

following:

- a. Clarifier drive impending overtorque (high torque) and shutdown overtorque (high-high torque) switches.
  - b. Clarifier drive local control panels.
2. Remote controls and status indication shall be provided by the electrical subcontractor and the instrumentation subcontractor included but not limited to the following:
- a. Manual control of clarifier drive at existing MCC-RAS-2.
  - b. Remote monitoring of clarifier drive status at the HMI via PLC-8. Clarifier no. 3 status signals shall be wired from the local control panels to PLC-8 and MCC-RAS-2. Refer to the Instrumentation Drawings, Section 17920 IO List and Electrical Drawings for detailed information.
3. Alarms and Interlocks:
- a. Automatic shutdown of clarifier drive upon high-high torque at MCC-RAS-2.

### 3.02 RAS PUMP STATION

#### A. Overview

The existing RAS pump, WAS flow control valve and clarifier flow control valves are monitored and controlled from PLC-8. The logic developed for PLC-8 shall follow the existing RAS pump control strategy. The existing HMI screens shall be modified as required by the PLC-8 logic. The control operations described below represent the minimum control requirements. Refer to Section 17920 IO List for a complete list of the required pump and valve control signals and status signals. Refer to Section 17300 for more information on the PLC and HMI modifications required.

#### B. Control Operations

##### 1. RAS Pumps

- a. Remote Manual - When a Pump VFD (variable frequency drive) HAND-OFF-REMOTE selector switch is in REMOTE, the pump shall be controlled by PLC-8. The operator is to start, stop and adjust the speed of the pump on the HMI. There shall be no automatic control of the RAS pumps.

##### 2. WAS and Clarifier Flow Control Valves

- a. Remote Manual - When valve LOCAL-STOP-REMOTE selector switch is in REMOTE, the valve shall be controlled by PLC-8. The operator is to manually adjust the position of the valve by entering a value between 0-100% open on the HMI.

### 3.03 TRANSFER PUMPS

A. Overview

The existing transfer pump control strategy shall be maintained. The control operations described below represent the minimum control requirements. Refer to Section 17920 IO List for a complete list of the required pump and valve control and status signals.

B. Control Operations

1. Transfer Pumps

- a. Remote Manual - When a Pump VFD (variable frequency drive) HAND-OFF-REMOTE selector switch is in REMOTE, the pump shall be controlled by PLC-8. The operator is to start, stop and adjust the speed of the pump on the HMI. There shall be no automatic control of the transfer pumps.

3.04 FLOW CONTROL VALVES

- A. The existing control strategy shall be maintained. Flow control valve position shall be manually adjusted from the HMI.

PART 4 – EXECUTION

(NOT USED)

- END OF SECTION -



# CITY OF HOLLYWOOD

## SOUTHERN REGIONAL WASTEWATER TREATMENT PLANT

**CONTRACT DOCUMENTS  
CLARIFIER NO. 3 REPAIR  
CITY PROJECT No. 22-9525  
BID SET  
ATTACHMENT E  
JANUARY 2023**

### CITY COMMISSION

- Josh Levy, Mayor**
- Caryl S. Shuham, Commissioner**
- Linda Hill Anderson, Commissioner**
- Traci L. Callari, Commissioner**
- Adam Gruber, Commissioner**
- Kevin D. Biederman, Commissioner**
- Idelma Quintana, Commissioner**
- Vin Morello, Director of Public Utilities**

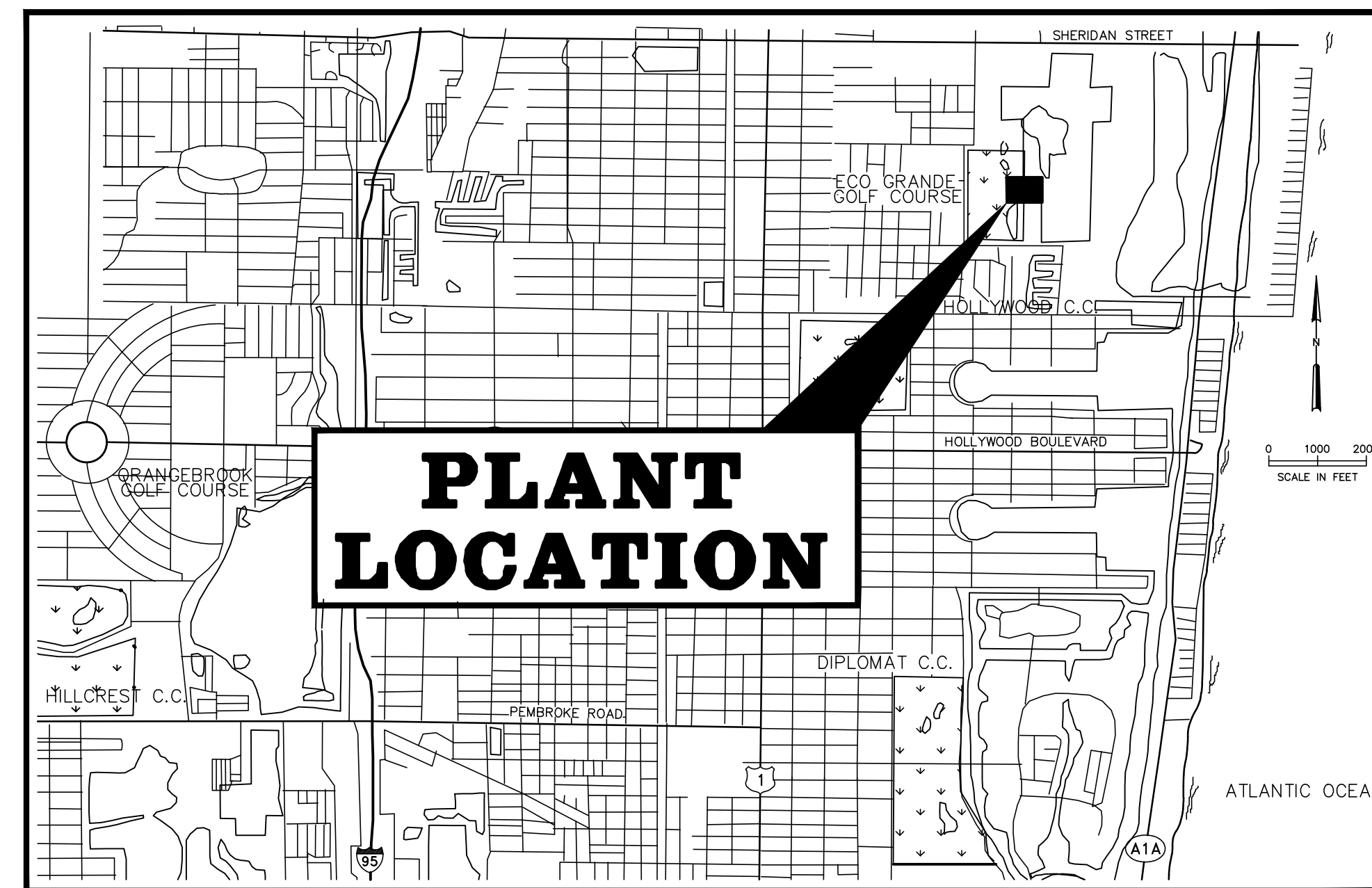

**LOCATION MAP**

NTS

### LIST OF DRAWINGS

SHEET NUMBER	SHEET TITLE	SHEET DESCRIPTION
<b>GENERAL</b>		
01	G-1	COVER SHEET, LOCATION MAP AND DRAWING LIST
02	G-2	ABBREVIATIONS, SYMBOLS, SECTION AND DETAIL IDENTIFICATION
03	G-3	SITE AND STAGING PLAN
<b>MECHANICAL</b>		
04	M-1	CLARIFIER NO.3 REPAIR – MECHANICAL REMOVAL AND REINSTALLATION PLAN
05	M-2	CLARIFIER NO.3 REPAIR – MECHANICAL REMOVAL AND REINSTALLATION SECTIONS
06	M-3	CLARIFIER NO.3 REPAIR – DETAILS
07	M-4	ALTERNATE BID ITEM A-1 THROUGH A-4 CLARIFIER NO.3 REPLACEMENT – PLAN
08	M-5	ALTERNATE BID ITEM A-1 THROUGH A-4 CLARIFIER NO.3 REPLACEMENT – SECTIONS
09	M-6	ALTERNATE BID ITEMS A-1 THROUGH A-4 CLARIFIER NO.3 REPLACEMENT – DETAILS
<b>ELECTRICAL</b>		
10	E-1	ELECTRICAL GENERAL NOTES
11	E-2	ELECTRICAL LEGEND AND SYMBOLS
12	E-3	ALTERNATIVE BID ITEMS A-1 & A-2 CLARIFIER NO.3 – ELECTRICAL PLAN
13	E-4	ALTERNATIVE BID ITEMS A-1 & A-2 RAS PS NO.2 – ELECTRICAL PLAN
14	E-5	ALTERNATIVE BID ITEMS A-1 & A-2 SINGLE LINE DRAWING
<b>INSTRUMENTATION</b>		
15	I-1	INSTRUMENTATION AND CONTROLS SYMBOLS AND LEGENDS
16	I-2	ALTERNATIVE BID ITEMS A-1 AND A-2 CLARIFIER NO.3 P&ID
17	I-3	INSTRUMENTATION AND CONTROLS DETAILS

COVER SHEET, LOCATION MAP AND DRAWING LIST

Sheet 01 of 17  
Drawing G-1

**Hazen**

HAZEN AND SAWYER  
4000 HOLLYWOOD BOULEVARD, SUITE 750N  
HOLLYWOOD, FLORIDA 33021  
CERTIFICATE OF AUTHORIZATION NO. : 2771

### ABBREVIATIONS

AB	ANCHOR BOLT	DN	DOWN	I	IRON	PAR	PARALLEL	SWBD	SWITCHBOARD
AC	ASBESTOS CEMENT	DOZ	DOZEN	ID	INSIDE DIAMETER	PC	POINT OF CURVE/PIECE	SWD	SIDE WATER DEPTH
ACT	ACOUSTIC TILE	DR	DOOR	IF	INSIDE FACE	PCC	POINT OF COMPOUND CURVE	SYM	SYMMETRICAL
AD	AREA DRAIN	DWG	DRAWING	IN	INCH	PCCP	PRESTRESSED CONCRETE CYLINDER PIPE		
ADDL	ADDITIONAL	DWL	DOWEL	INCL	INCLUDED	PCF	POUNDS PER CUBIC FOOT		
ADJ	ADJUSTABLE			INF	INFLUENT	PE LINING	POLYETHYLENE LINING	T	TREAD
AFF	ABOVE FINISHED FLOOR	E	EAST/EASEMENT	INS	INSULATION	PERF	PERFORATED	T&B	TOP AND BOTTOM
AGGR	AGGREGATE	EA	EACH	INT	INTERIOR	PERP	PERPENDICULAR	T&G	TONGUE AND GROOVE
AL	ALUMINUM	ECC	ECCENTRIC	INV	INVERT	PI	POINT OF INTERSECTION	TAN	TANGENT
ALLOW	ALLOWANCE/ALLOWABLE	EF	EACH FACE			PL	PROPERTY LINE/PLATE	TBM	TEMPORARY BENCH MARK
ALT	ALTERNATE	EFF	EFFLUENT			PNL	PANEL	TC	TOP OF CURB
APPROX	APPROXIMATE	EIP	EXIST IRON PIPE	J	JOIST	PP	POWER POLE	TDH	TOTAL DYNAMIC HEAD
ARCH	ARCHITECTURAL	EL OR ELEV	ELEVATION	JB	JUNCTION BOX	PREFAB	PREFABRICATED	TECH	TECHNICAL
ASB	ASBESTOS	ELEC	ELECTRIC/ELECTRICAL	JCT	JUNCTION	PRV	PRESSURE RELIEF VALVE	TEL	TELEPHONE
ASPH	ASPHALT	ELL	ELBOW	JT	JOINT	PS	PUMPING STATION	TEMP	TEMPERATURE
AT	ASPHALT TILE	EMH	ELECTRICAL MANHOLE			PSF	POUNDS PER SQUARE FOOT	TER	TERRAZZO
		ENGR	ENGINEER			PSI	POUNDS PER SQUARE INCH	THERMO	THERMOSTAT
		ENT	ENTRANCE	L	LENGTH/ANGLE	PT	POINT OF TANGENT/POINT	THK	THICK
B	BORING	EOG	EDGE OF GRAVEL	LA	LINE AHEAD	PTN	PARTITION	THRU	THROUGH
BD	BOARD	EOP	EDGE OF PAVEMENT	LAB	LABORATORY	PV	PLUG VALVE	TOD	TOP OF DECK
BFE	BOTTOM OF FITTING ELEVATION	EQ	EQUAL	LAM	LAMINATED	PVC	POLYVINYL CHLORIDE	TOF	TOP OF FOOTING
BFV	BUTTERFLY VALVE	EQPT	EQUIPMENT	LAV	LAVATORY	PWMT	PAVEMENT	TOM	TOP OF MASONRY/MANHOLE
BITUM	BITUMINOUS	EW	EACH WAY	LAT	LAVATORY	PW	POTABLE WATER	TOS	TOP OF SLAB
BL	BASELINE/BUILDING LINE	EX	EXISTING	LAV	LAVATORY			TOW	TOP OF WALL
BLDG	BUILDING	EXC	EXCAVATE	LB	POUND/LINE BACK			TOL	TOLERANCE
BLK	BLOCK	EXH	EXHAUST	LF	LINEAR FEET			TPS	TWISTED PAIR SHIELDED
BM	BENCH MARK	EXP	EXPANSION	LG	LONG	QTY	QUANTITY	TRANS	TRANSFORMER
BOC	BACK OF CURB	EXT	EXTERIOR	LL	LIVE LOAD			TYP	TYPICAL
BOT	BOTTOM			LLH	LONG LEG HORIZONTAL				
BRG	BEARING			LLV	LONG LEG VERTICAL	R	RADIUS/RISER	UGC	UNDERGROUND CONDUIT
BRK	BRICK	FAB	FABRICATE	LP	LIGHT POLE	RCP	REINFORCED CONCRETE PIPE	UGE	UNDERGROUND ELECTRIC
BRZ	BRONZE	F&C	FRAME AND COVER	LPT	LOW POINT	RD	ROAD/ROOF DRAIN	UH	UNIT HEATER
BSTM	BASEMENT	F&G	FRAME AND GRATE	LT	LIGHT	RECIR	RECIRCULATION	UNFIN	UNFINISHED
BT	BOLT	FC	FLUSHING CONNECTION	LTG	LIGHTING	RECP	RECEPTACLE	UNO	UNLESS NOTED OTHERWISE
BUR	BUILT-UP ROOFING	FCC	FLUSHING CONNECTION	LVR	LOUVER	RECT	RECTANGULAR	UR	URINAL
BV	BALL VALVE	FD	FLOOR DRAIN	LWL	LOW WATER LEVEL	RED	REDUCER	URINAL	URINAL
		FDN	FOUNDATION			REF	REFERENCE	UTIL	UTILITY
		FE	FIRE EXTINGUISHER			REG	REGISTER		
C	CABLE/CONDUIT	FF	FINISH FLOOR	MAINT	MAINTENANCE	REIN	REINFORCING	VAC	VACUUM
CAP	CORRIGATED ALUMINUM PIPE	FH	FIRE HYDRANT	MATL	MATERIAL	REMF	REMOVING	VAT	VINYL ASBESTOS TILE
CATV	CABLE TELEVISION	FIN	FINISH	MAX	MAXIMUM	REQD	REQUIRED	VCP	VITRIFIED CLAY PIPE
CB	CATCH BASIN	FIX	FIXTURE	MECH	MECHANICAL	REST	RESTRAINED	VEL	VELOCITY
C/C	CENTER TO CENTER	FL	FLASHING/FLOOR	MEMB	MEMBRANE	REV	REVISE	VENT	VENTILATING/VENTILATION
CCFRPM	CENTRIFUGAL CAST FIBERGLASS REINFORCED POLYMER MORTAR	FLEX	FLEXIBLE	MET	METAL	RF	ROOF	VERT	VERTICAL
		FLG	FLANGE	MFGR	MANUFACTURER	RFG	ROOFING	VOL	VOLUME
CE	CONSTRUCTION EASEMENT	FLUOR	FLUORESCENT	MG	MILLION GALLONS	RJ	RESTRAINED JOINT	VP	VENT PIPE
CEM	CEMENT	FLXC	FLEXIBLE CONNECTION	MGD	MILLION GALLONS PER DAY	RM	ROOM	VWC	VINYL WALL COVERING
CER	CERAMIC	FM	FIBER OPTIC CABLE	MH	MANHOLE	RND	ROUND		
CF	CUBIC FEET	FOC	FIREPROOF	MIN	MINIMUM	RO	ROUGH OPENING	W	WATER/WEST/WIDTH
CFM	CUBIC FEET PER MINUTE	FRP	FIBERGLASS REINFORCED	MISC	MISCELLANEOUS	RPM	REVOLUTIONS PER MINUTE	W/	WITH
CI	CAST IRON/CUBIC INCHES			MJ	MECHANICAL JOINT	RR	RAILROAD	WC	WATER CLOSET
CIP	CAST IRON PIPE	FT	FOOTING/FITTING	MLDG	MOLDING	RT	REMOTE TERMINAL UNIT	WF	WIDE FLANGE
CL	CENTER LINE	FTG	FOOTING/FITTING	MO	MASONRY OPENING	RTU	REMOTE TERMINAL UNIT	WH	WALL HYDRANT
CL <sub>2</sub>	CHLORINE	FURR	FURRING/FURRED	MOD	MODIFY/MODIFIED	RW	RAW WATER	WI	WROUGHT IRON
CLG	CEILING			MON	MONUMENT	R/W	RIGHT OF WAY	WL	WATER LEVEL
CLKG	CAULKING			MOT	MOTOR			W/L	WATER LINE
CLR	CLEAR	G	GAS/GAS LINE	MTD	MOUNTED			WO	WITHOUT
CMP	CORRUGATED METAL PIPE	GA	GAUGE	MTG	MOUNTING	S	SOUTH/SLOPE	WP	WATERPROOF
CMU	CONCRETE MASONRY UNIT	GAL	GALLON	MULT	MULTIPLE	SAN	SANITARY	WPFG	WATER PROOFING
CO	CLEANOUT	GALV	GALVANIZED			SBL	SURVEY BASELINE	WPT	WALL PENETRATING TYPE
COL	COLUMN	GC	GENERAL CONTRACTOR			SCH	SCHEDULE	WSE	WATER SURFACE ELEVATION
CONC	CONCRETE	GEN	GENERATOR	N	NORTH	SD	STORM/SITE DRAIN	WSP	WEATHERSTRIP
CONST	CONSTRUCTION	GI	GALVANIZED IRON	NA	NOT APPLICABLE	SECT	SECTION	WSP	WEATHERSTRIP
CONT	CONTINUOUS	GL	GLASS	NF	NEAR FACE	SEW	SEWER	WT	WEIGHT
CONTR	CONTRACTOR	GPM	GALLONS PER MINUTE	NIC	NOT IN CONTRACT	SF	SQUARE FEET	WT	WEIGHT
CORP	CORPORATION	GR	GRADE	NO	NUMBER	SHT	SHEET	WV	WATER VALVE
CORR	CORRIDOR	GV	GATE VALVE	NOM	NOMINAL	SI	SQUARE INCH	WWF	WELDED WIRE FABRIC
CP	CONCRETE PLANK	GW	GUY WIRE	NPW	NON POTABLE WATER	SJ	SIMILAR		
CRS	COURSE	GW	GUY WIRE	NTS	NOT TO SCALE	SJ	STEEL JOIST		
CT	CERAMIC TILE	CWB	GYP SUM WALL BOARD			SPEC	SPECIFICATION		
CTJ	CONTROL JOINT	GW	GLAZED WALL FINISH			SQ	SQUARE		
CU	COPPER	GYP	GYP SUM			SS	SANITARY SEWER		
CV	CHECK VALVE			OC	ON CENTER	SST	STAINLESS STEEL		
CW	COLD WATER	H	HEIGHT	OD	OUTSIDE DIAMETER	ST	STREET		
CY	CUBIC YARD	HDW	HARDWARE	OF	OUTSIDE FACE	STA	STATION		
		HEX	HEXAGONAL	OFF	OFFICE	STD	STANDARD		
DC	DIRECT CURRENT	HM	HOLLOW METAL	OPER	OPERATOR	STG	STORAGE		
DET	DETAIL	HORZ	HORIZONTAL	OPNG	OPENING	STR	STIRRUP		
DF	DRINKING FOUNTAIN	HP	HORSEPOWER	OPP	OPPOSITE	STL	STEEL		
DIA (ø)	DIAMETER	HPT	HIGH POINT	ORIG	ORIGINAL	STR	STRUCTURAL		
DIAG	DIAGONAL	HTR	HEATER	OT	OPEN TRUSS	SUB	SUBSTITUTE		
DIM	DIMENSION	HVAC	HEATING, VENTILATION AND AIR CONDITIONING	OHE	OVERHEAD ELECTRIC	SUP	SUPPLY		
DIP	DUCTILE IRON PIPE					SUPT	SUPERINTENDENT		
DISCH	DISCHARGE	HW	HOT WATER			SUR	SURFACE		
DIST	DISTRIBUTION	HWL	HIGH WATER LEVEL			SUSP	SUSPENDED		
DJ	DOUBLE JOIST	HWY	HIGHWAY			SW	SWITCH		
DL	DEAD LOAD	HYD	HYDRAULIC						

### SYMBOLS

	SOLENOID		SOIL BORING
	MOTOR OPERATED		CONCRETE UTILITY POLE
	BALL VALVE		EXISTING ELEVATION
	BALL CHECK VALVE		CENTER LINE
	BUTTERFLY VALVE/DAMPER		OVERHEAD WIRES
	CHECK VALVE		PROPERTY LINE
	CHECK VALVE		RIGHT-OF-WAY LINE
	DIAPHRAGM VALVE		UNDERGROUND CONDUIT
	GATE VALVE		UNDERGROUND GAS PIPE
	PRESSURE GAUGE SEAL		UNDERGROUND FORCE MAIN
	PRESSURE GAUGE		UNDERGROUND FIBER OPTIC LINE
	PLUG VALVE		UNDERGROUND SANITARY SEWER PIPE
	THREE WAY VALVE		UNDERGROUND STORM DRAIN PIPE
	PRESSURE REDUCING/RELIEF VALVE		UNDERGROUND UNKNOWN LINE
	PRESSURE REGULATING VALVE		UNDERGROUND WATER PIPE
	PRESSURE RELIEF VALVE		
	MECHANICAL COUPLING		
	HARNESSED MECHANICAL COUPLING		
	EXPANSION JOINT		
	UNION		
	FIRE HYDRANT		
	MAGNETIC METER		
	MANHOLE		
	PROPOSED PIPELINE/STRUCTURE		
	EXISTING UTILITIES/STRUCTURE		
	PROPOSED PIPELINE (DOUBLE LINE IF SCALE OF DRAWING PERMITS)		
	PUMP		
	FLANGED JOINT		
	MECHANICAL JOINT		
	PUSH-ON JOINT		
	THREADED 45° ELBOW JOINT		
	PROPOSED STRUCTURE OR FACILITY		
	REDUCER (SINGLE LINE)		
	REDUCER (DOUBLE LINE)		
	CONCRETE PIPE SUPPORT		
	QUICK CONNECT		
	CATCH BASIN		
	FIRE HYDRANT		
	LIGHT POLE		
	SIGN (UNLESS NOTED)		
	WATER METER		
	WOOD UTILITY POLE		
	WALL MOUNTED LIGHTS		

#### SECTION IDENTIFICATION

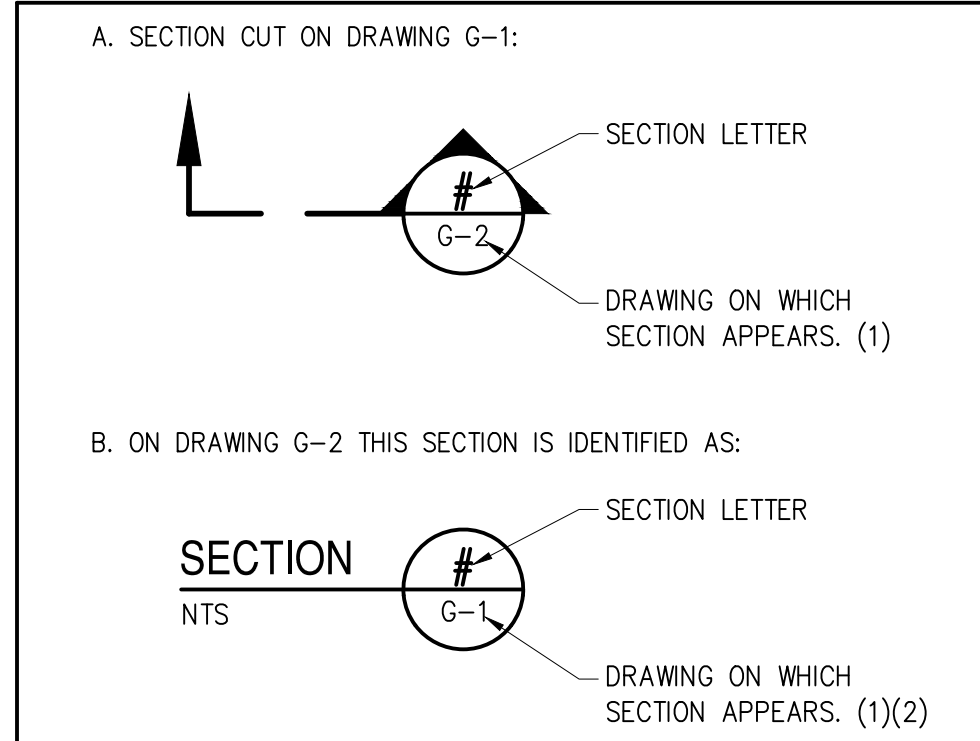

#### DETAIL IDENTIFICATION

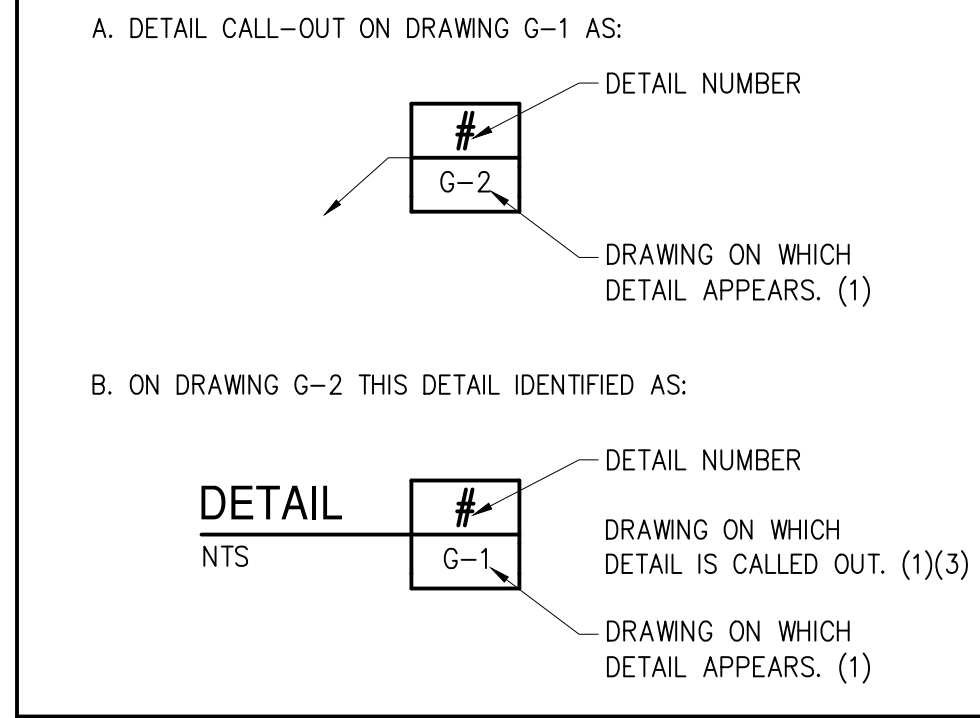

NOTES:

- (1) IF PLAN AND SECTION (OR DETAIL CALL-OUT AND DETAIL) ARE SHOWN ON SAME DRAWING, DRAWING NUMBER IS REPLACE BY A DASH (-).
- (2) IF SECTION IS SHOWN IN TWO OR MORE LOCATIONS, THE FIRST DRAWING NUMBER WHERE THE SECTION IS SHOWN IS DISPLAYED IN THE SECTION TITLE.
- (3) IF A DETAIL IS SHOWN IN TWO OR MORE LOCATIONS, THE DRAWING NUMBER IN THE DETAIL TITLE IS REPLACED WITH A LINE.

GENERAL NOTES:

- (1) FOR WELDING SYMBOLS USE AMERICAN WELDING SOCIETY STANDARD SYMBOLS.

\* DENOTES DIMENSIONS OR ELEVATIONS DEPENDENT ON EQUIPMENT SUPPLIED.

DESIGNED	TAV		
DRAWN	TB		
CHECKED	JPC		
PROJ. ENGR.	TAV		
NO.	DATE	ISSUED FOR	BY

DESIGNED	TAV	
DRAWN	TB	
CHECKED	JPC	
PROJ. ENGR.	TAV	
J. PHILIP COOKE	P.E.	No. 47137

**Hazen**

HAZEN AND SAWYER  
4000 HOLLYWOOD BOULEVARD, SUITE 750N  
HOLLYWOOD, FLORIDA 33021

THE SCALE BAR SHOWN BELOW MEASURES ONE INCH LONG ON THE ORIGINAL DRAWING.

CONTRACT:	-
CLIENTS PROJECT:	22-9525
ENGINEERS PROJECT:	4321-095
CAD REFERENCE:	4321-095-002

CITY OF HOLLYWOOD

SOUTHERN REGIONAL WASTEWATER TREATMENT PLANT  
CLARIFIER No. 3 REPAIR

ABBREVIATIONS, SYMBOLS, SECTION AND DETAIL IDENTIFICATION

DATE:	JANUARY 2023
SHEET:	02 OF 17
DRAWING:	G-2

BID SET

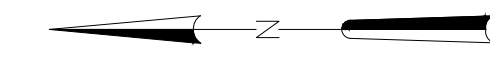

NOTES:

1. THE CONTRACTOR'S PARKING LOT INCLUDES PARKING SPACES FOR OTHER PROJECTS. THE CLARIFIER No. 3 REPAIR PROJECT HAS 4 SPACES ALLOCATED. PARKING LOT SURFACE IS CRUSHED STONE.
2. CONTRACTOR TO ENSURE THAT PLANT ACCESS ROADWAY IS KEPT OPEN. OBTAIN PRIOR WRITTEN APPROVAL BY THE CITY BEFORE RESTRICTING OR BLOCKING ACCESS.
3. CONTRACTOR SHALL REFER TO SPECIFICATION 01550 FOR ADDITIONAL REQUIREMENTS REGARDING SITE ACCESS AND STORAGE.
4. CONTRACTOR SHALL REFER TO SPECIFICATION 01510 FOR TEMPORARY UTILITIES AND SERVICES DURING CONSTRUCTION.
5. CONTRACTOR SHALL PROVIDE ADEQUATE CLEARANCE AROUND EXISTING VALVES WITHIN STAGING AREA. ACCESS TO VALVES BY OWNER SHALL BE MAINTAINED AT ALL TIMES.
6. BACKFILL AND COMPACT WITH NATIVE MATERIAL.
7. REPAIR ANY ASPHALT, CURB, GUTTER AND/OR SOD DAMAGED DURING CONSTRUCTION.
8. SOD SHALL BE BAHIA SOD.

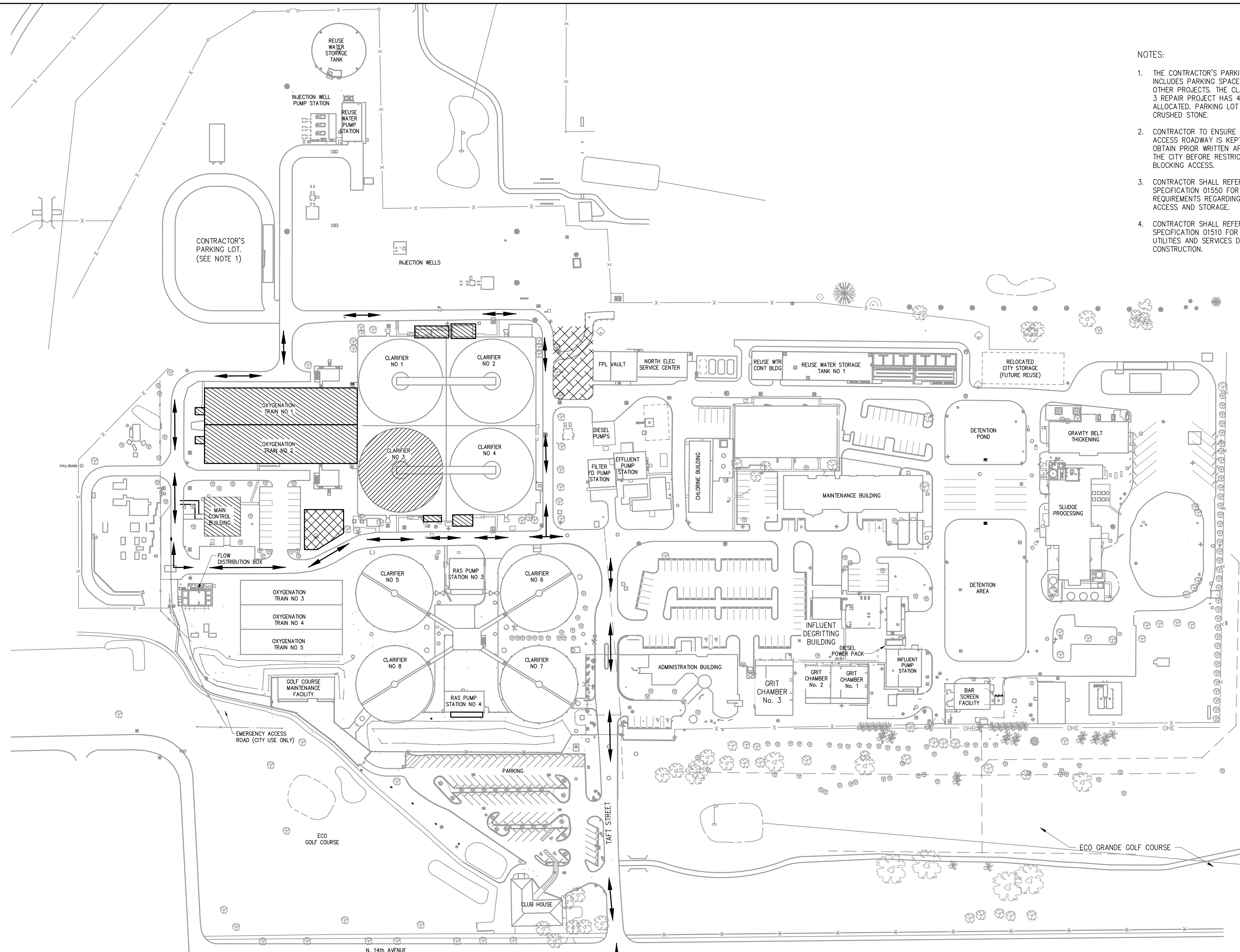

LEGEND

- EXISTING
- - - FUTURE
- CONTRACTOR TRAFFIC FLOW
- [Diagonal Hatching] CLARIFIERS No. 3 REPAIR (THIS CONTRACT)
- [Cross-hatch] STAGING AREA
- [Grid Pattern] CONTRACTOR PARKING AREA
- [Diagonal Hatching] RAS PUMP STATION NO.1 REPLACEMENT (BY OTHERS)

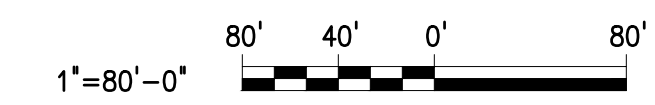

PLOT DATE: 1/5/2023 11:27 AM BY: IBOCAS

DESIGNED	TAV		
DRAWN	TB		
CHECKED	JPC		
PROJ. ENGR.	TAV		
NO.	DATE	ISSUED FOR	BY

J. PHILIP COOKE  
No. 47137

P.E.

**Hazen**

HAZEN AND SAWYER  
4000 HOLLYWOOD BOULEVARD, SUITE 750N  
HOLLYWOOD, FLORIDA 33021

THE SCALE BAR SHOWN BELOW MEASURES ONE INCH LONG ON THE ORIGINAL DRAWING.

CONTRACT: -  
CLIENTS PROJECT: 22-9525  
ENGINEERS PROJECT: 4321-095  
CAD REFERENCE: 4321-095-003



CITY OF HOLLYWOOD

SOUTHERN REGIONAL WASTEWATER TREATMENT PLANT  
CLARIFIER No. 3 REPAIR  
SITE AND STAGING PLAN

DATE: JANUARY 2023  
SHEET: 03 OF 17  
DRAWING: G-3

BID SET



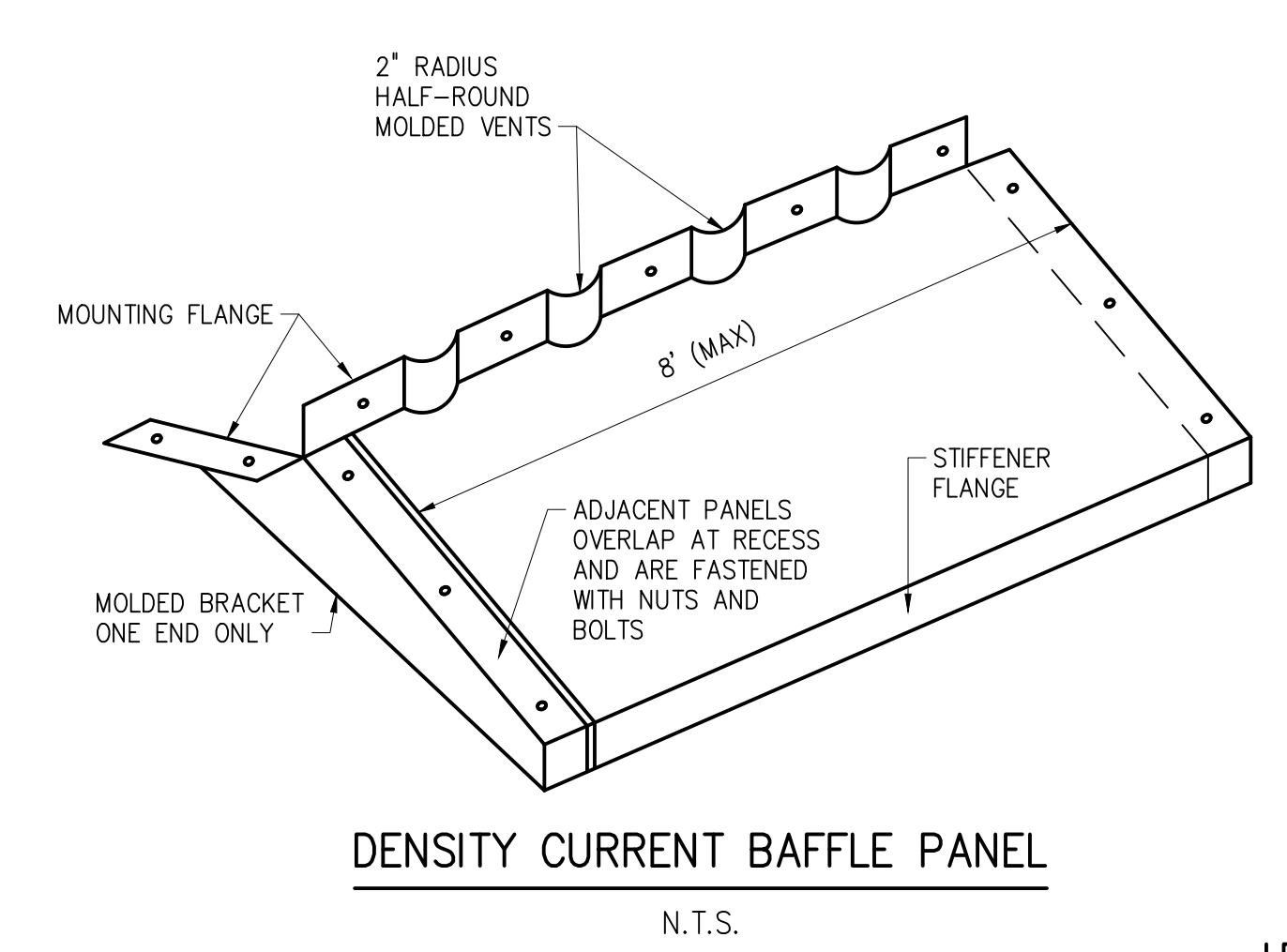
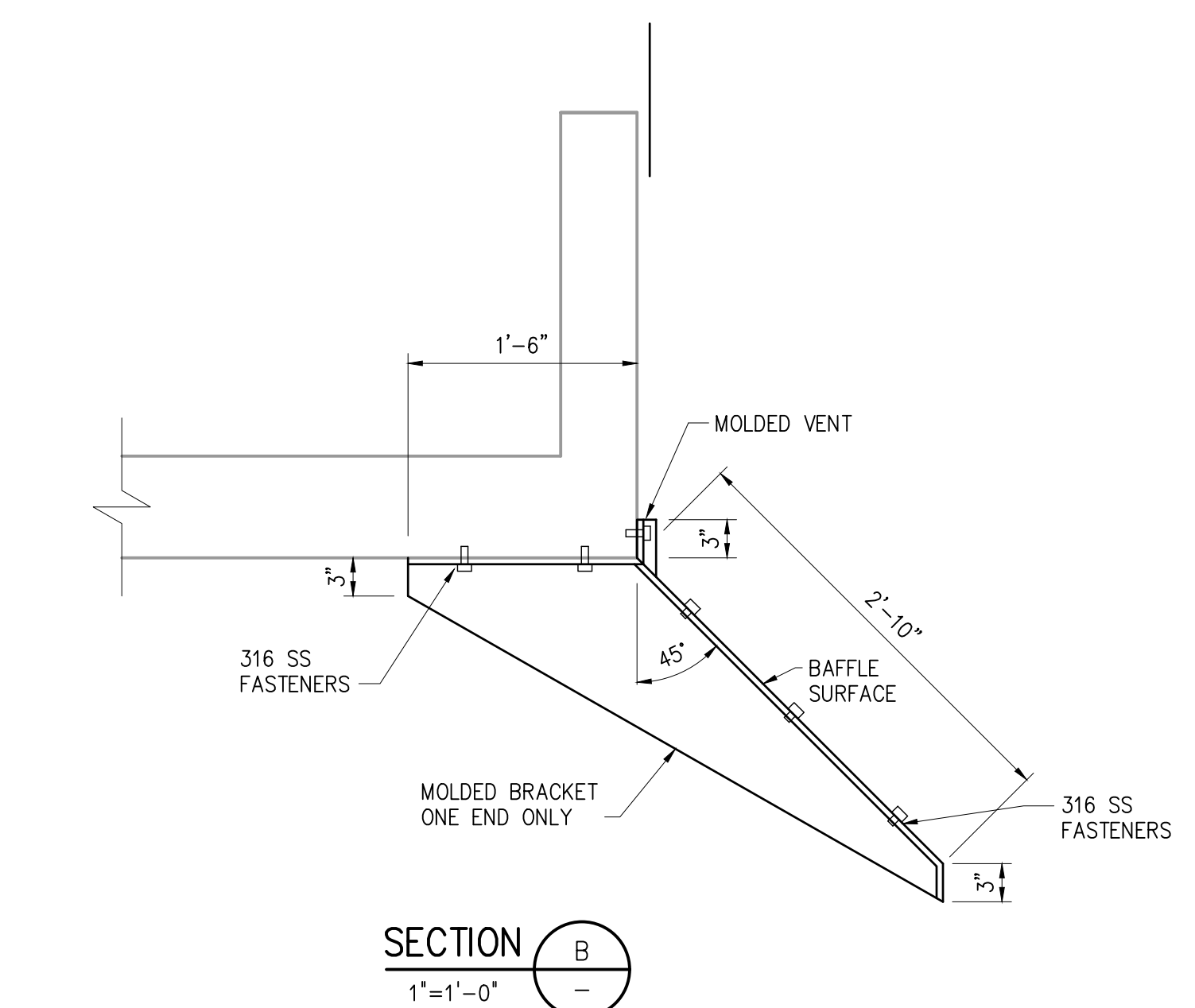
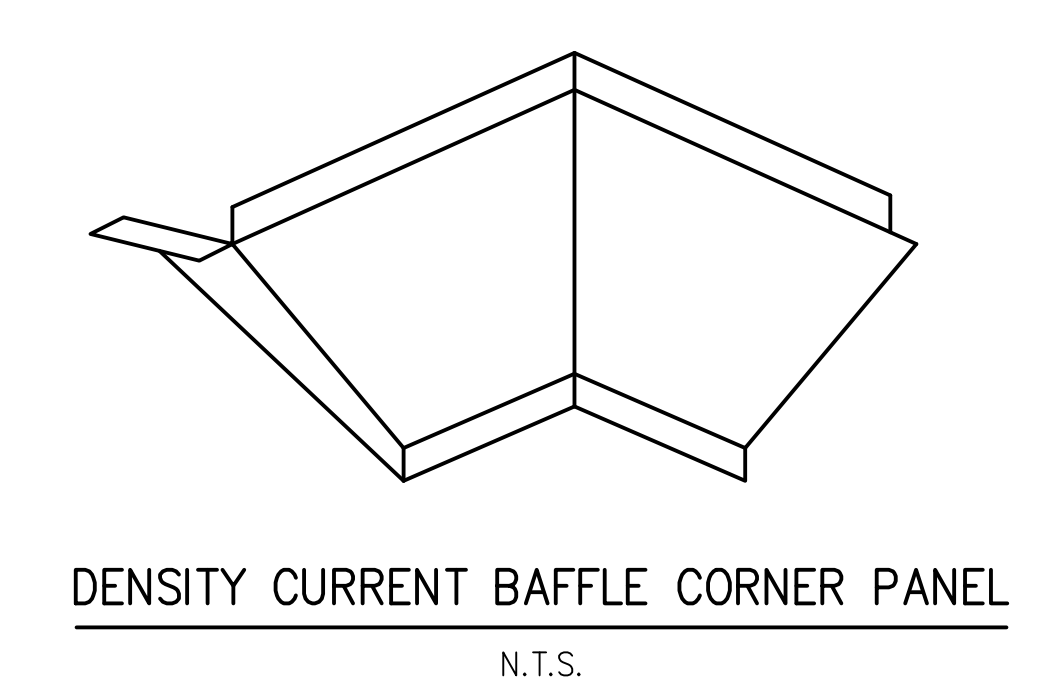
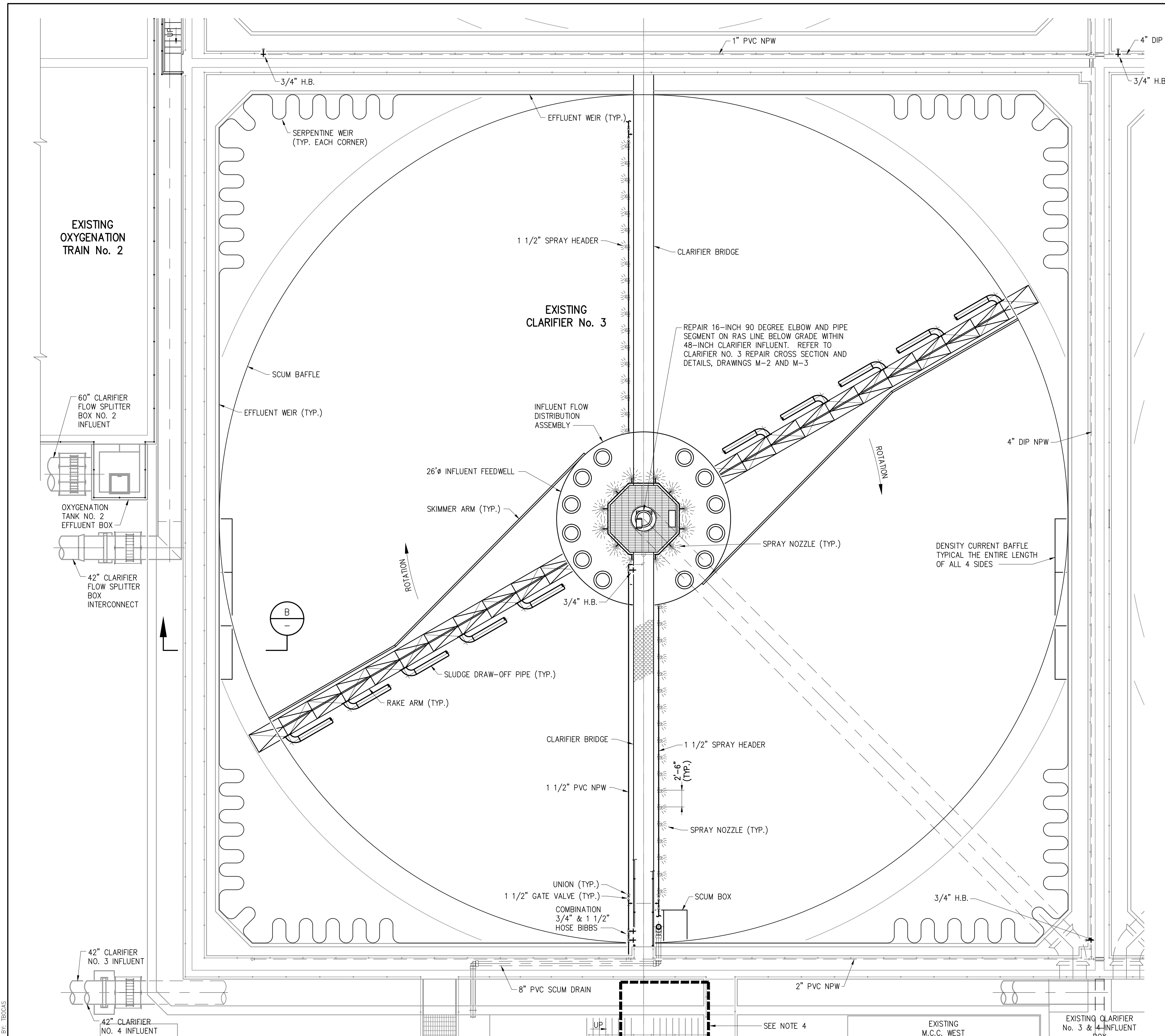

- NOTES:
- CONTRACTOR TO REMOVE AND PROTECT CLARIFIER EQUIPMENT AS NECESSARY, IN ORDER TO PERFORM SPECIFIED REPAIR WORK ON 16-INCH RETURN SLUDGE LINE (REFER TO M-2 AND M-3).
  - PROVIDE NEW 316 SS HARDWARE, INCLUDING NUTS, WASHERS, AND ACCESSORIES WITH RE-INSTALLATION OF EQUIPMENT.
  - ENGINEER AND CITY SHALL BE NOTIFIED UPON REMOVAL OF EQUIPMENT AND PRIOR TO RE-INSTALLATION FOR REVIEW. SHOULD EXCESSIVE REPAIRS BE REQUIRED, CITY MAY EXECUTE ALTERNATIVE BID ITEMS A-1 OR A-2 FOR COMPLETE MECHANISM REPLACEMENT.

- NOTES:
- CLARIFIER No. 3 SHOWN.
  - REFER TO DRAWING M-3 FOR CLARIFIER REPAIR DETAILS.
  - DISMANTLE AND REMOVE MECHANISM AS NECESSARY TO PERFORM THE WORK. CLARIFIER EQUIPMENT SHALL BE PROTECTED AND RE-INSTALLED.
  - REFER TO DRAWING M-3 FOR NEW 16" PLUG VALVE DETAILS.

**LEGEND**

— EXISTING FACILITY

— EQUIPMENT TO BE DISMANTLED, REMOVED, PROTECTED AND RE-INSTALLED AS NECESSARY.

1' = 1'-0"

1/8" = 1'-0"

PLOT DATE: 1/5/2023 11:29 AM BY: TBODAS

NO.	DATE	ISSUED FOR	BY

DESIGNED	TAV
DRAWN	TB
CHECKED	JPC
PROJ. ENGR.	TAV

J. PHILIP COOKE  
No. 47137

**Hazen**

HAZEN AND SAWYER  
4000 HOLLYWOOD BOULEVARD, SUITE 750N  
HOLLYWOOD, FLORIDA 33021

CONTRACT:	-
CLIENTS PROJECT:	22-9525
ENGINEERS PROJECT:	4321-095
CAD REFERENCE:	8242-095-M01

CITY OF HOLLYWOOD  
SEAL OF THE CITY OF HOLLYWOOD, FLORIDA  
INCORPORATED 1925

SOUTHERN REGIONAL WASTEWATER TREATMENT PLANT  
CLARIFIER No. 3 REPAIR  
CLARIFIER NO.3 REPAIR -- MECHANICAL  
REMOVAL AND REINSTALLATION PLAN

DATE:	JANUARY 2023
SHEET:	04 OF 17
DRAWING:	M-1

BID SET

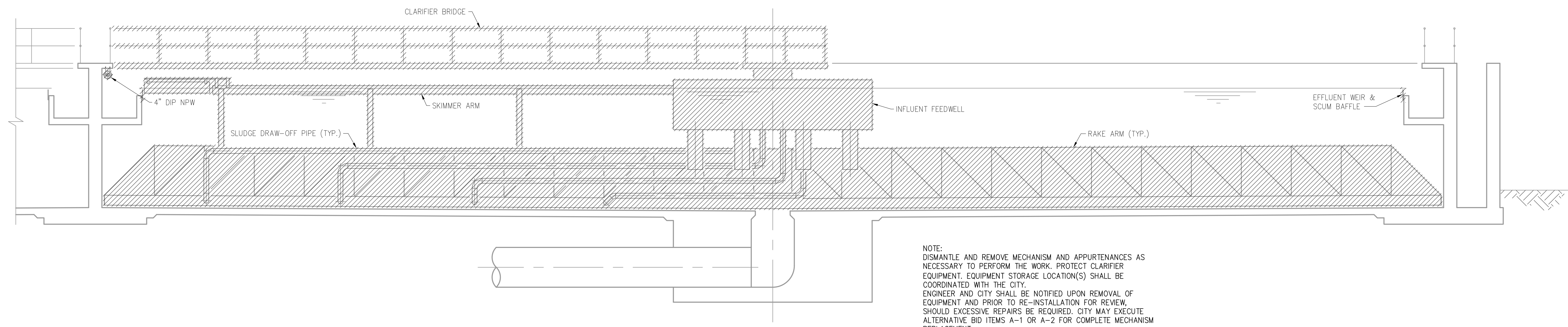

**EQUIPMENT REMOVAL**  
**ILLUSTRATIVE CROSS SECTION**  
 3/16"=1'-0"

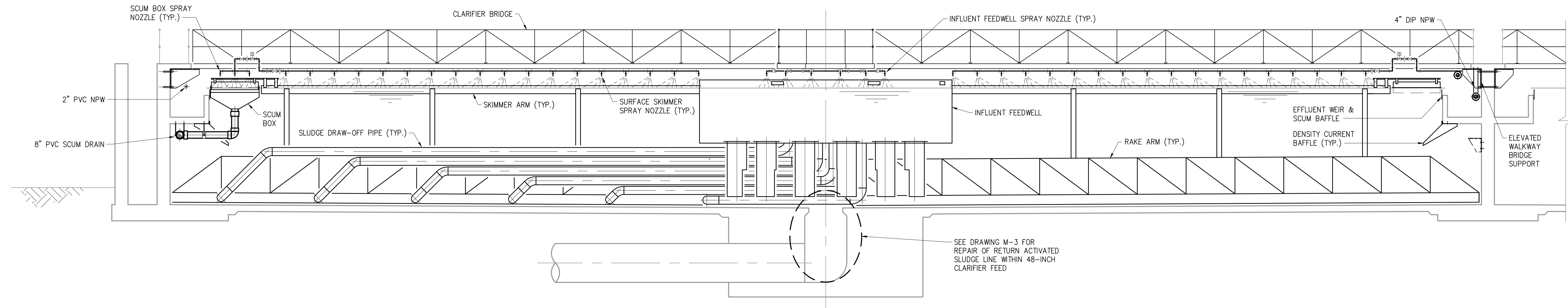

**EQUIPMENT RE-INSTALLATION**  
**ILLUSTRATIVE CROSS SECTION**  
 3/16"=1'-0"

**LEGEND**

	EXISTING FACILITY
	TO BE RE-INSTALLED UPON CITY APPROVAL
	TO BE REMOVED AS NECESSARY



PLOT DATE: 1/5/2023 11:29 AM BY: TB004S

NO.	DATE	ISSUED FOR	BY

DESIGNED	TAV
DRAWN	TB
CHECKED	JPC
PROJ. ENGR.	TAV

**J. PHILIP COOKE**  
 No. 47137  
 P.E.

**Hazen**  
 HAZEN AND SAWYER  
 4000 HOLLYWOOD BOULEVARD, SUITE 750N  
 HOLLYWOOD, FLORIDA 33021

THE SCALE BAR SHOWN BELOW MEASURES ONE INCH LONG ON THE ORIGINAL DRAWING.

CONTRACT:	—
CLIENTS PROJECT:	22-9525
ENGINEERS PROJECT:	4321-095
CAD REFERENCE:	8242-095-M02

CITY OF HOLLYWOOD

SOUTHERN REGIONAL WASTEWATER TREATMENT PLANT  
 CLARIFIER No. 3 REPAIR  
**CLARIFIER NO.3 REPAIR – MECHANICAL REMOVAL AND REINSTALLATION SECTIONS**

DATE:	JANUARY 2023
SHEET:	05 OF 17
DRAWING:	M-2

**BID SET**

NOTE:  
CLARIFIER No. 3 SHOWN.



CLARIFIER No. 3 EXISTING  
16-INCH RAS LINE REPAIR

PHOTO 1  
NTS

BROKEN  
16-INCH RAS  
ELBOW AND  
MEGA-LUG

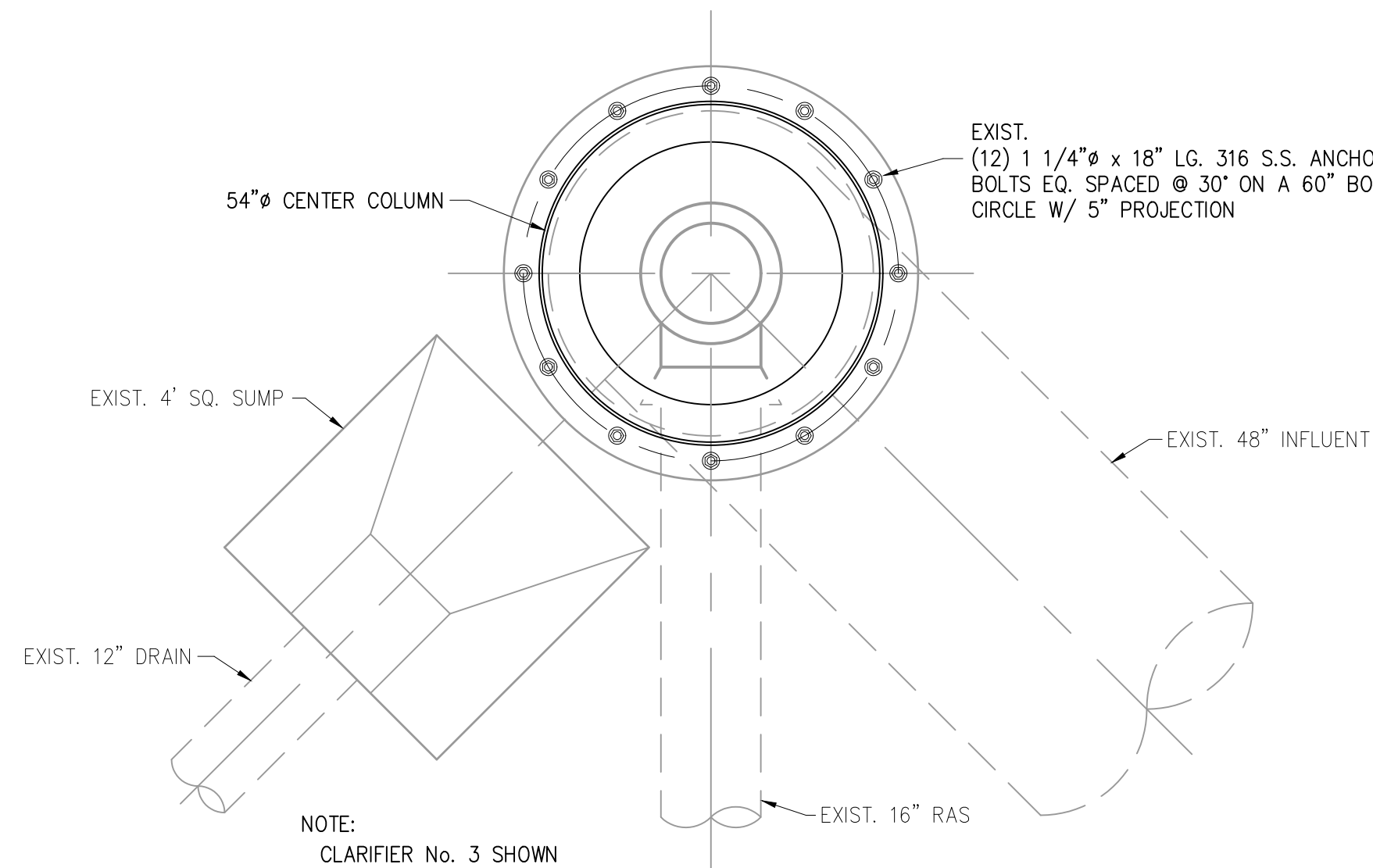

NOTE:  
CLARIFIER No. 3 SHOWN

REPAIR  
PLAN

1/2"=1'-0"

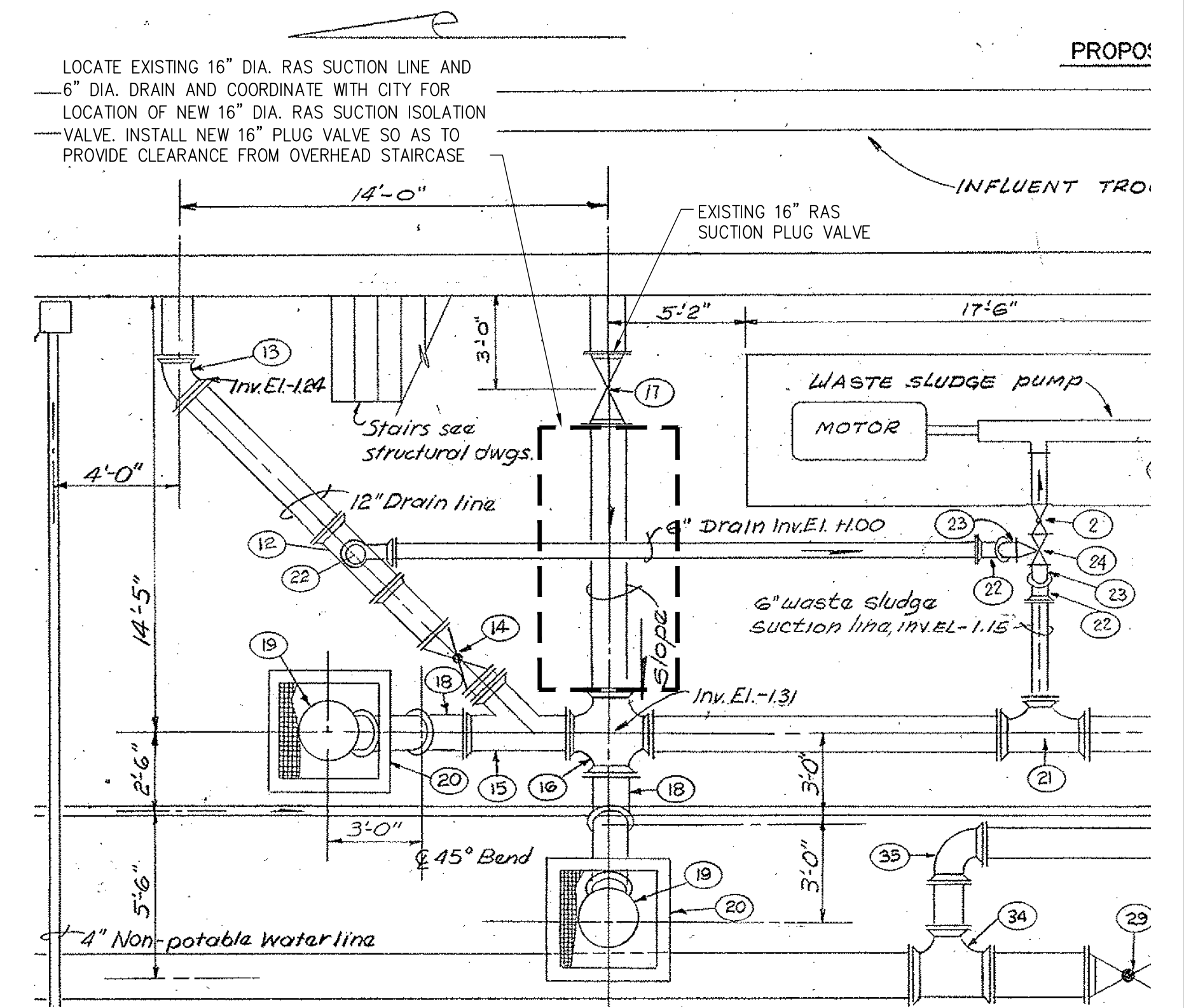

16" PLUG VALVE LOCATION  
DETAIL  
NTS

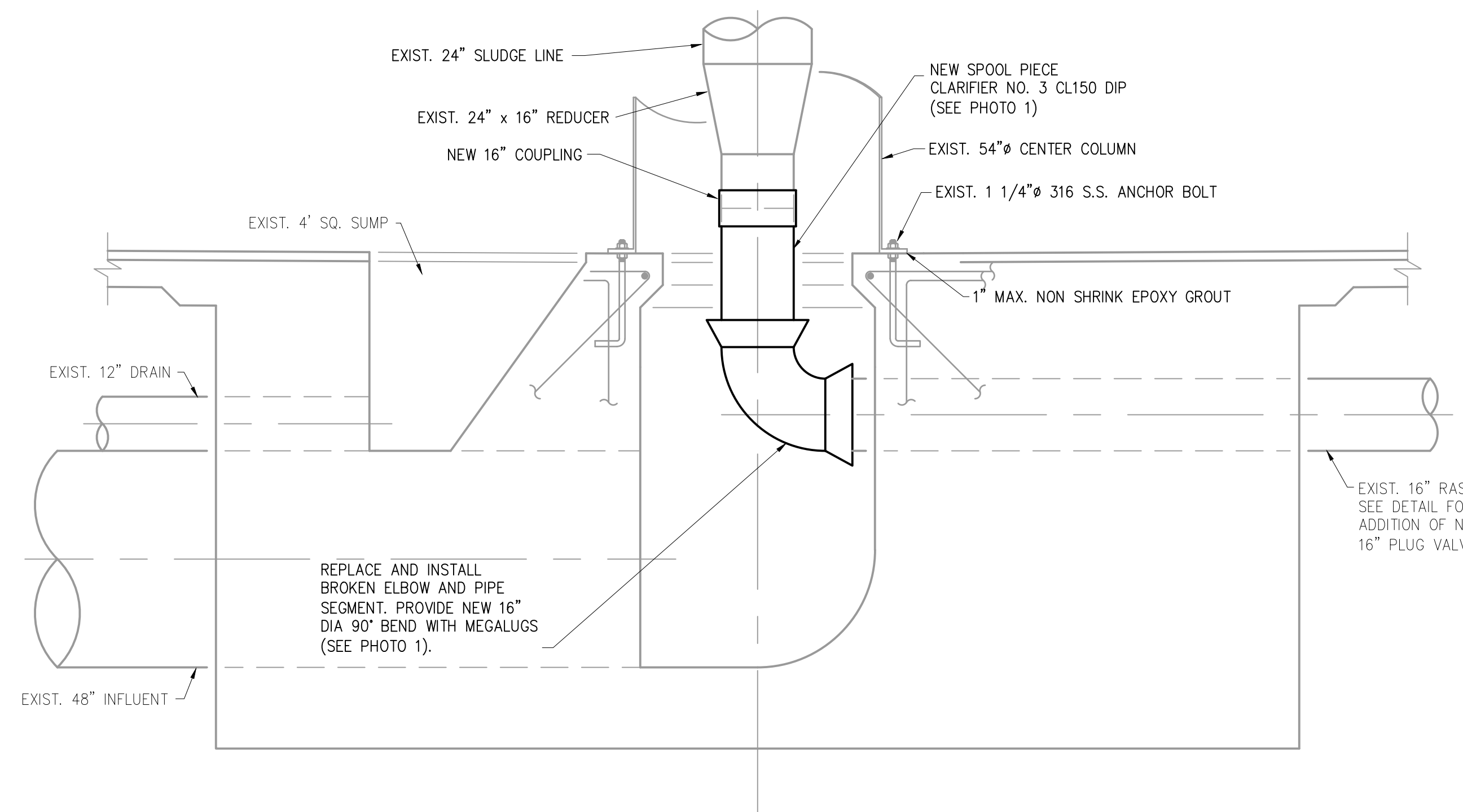

REPAIR  
ILLUSTRATIVE CROSS SECTION

1/2"=1'-0"

LEGEND

	EXISTING FACILITIES
	NEW FACILITIES
	TO BE REMOVED

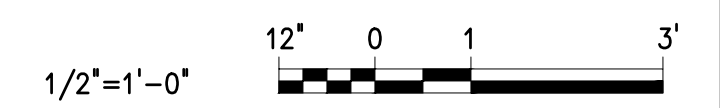

PLOT DATE: 1/5/2023 11:26 AM BY: TBODAS

DESIGNED	TAV		
DRAWN	TB		
CHECKED	JPC		
PROJ. ENGR.	TAV		
NO.	DATE	ISSUED FOR	BY

J. PHILIP COOKE No. 47137	P.E.
------------------------------	------

**Hazen**  
HAZEN AND SAWYER  
4000 HOLLYWOOD BOULEVARD, SUITE 750N  
HOLLYWOOD, FLORIDA 33021

THE SCALE BAR SHOWN BELOW MEASURES ONE INCH LONG ON THE ORIGINAL DRAWING.

CONTRACT:	-
CLIENTS PROJECT:	22-9525
ENGINEERS PROJECT:	4321-095
CAD REFERENCE:	8242-095-M03

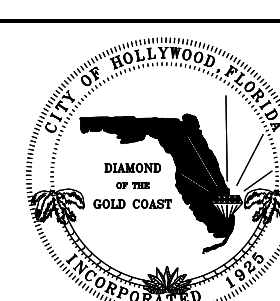

CITY OF HOLLYWOOD

SOUTHERN REGIONAL WASTEWATER TREATMENT PLANT
CLARIFIER No. 3 REPAIR
CLARIFIER NO.3 REPAIR - DETAILS

DATE:	JANUARY 2023
SHEET:	06 OF 17
DRAWING:	M-3

BID SET

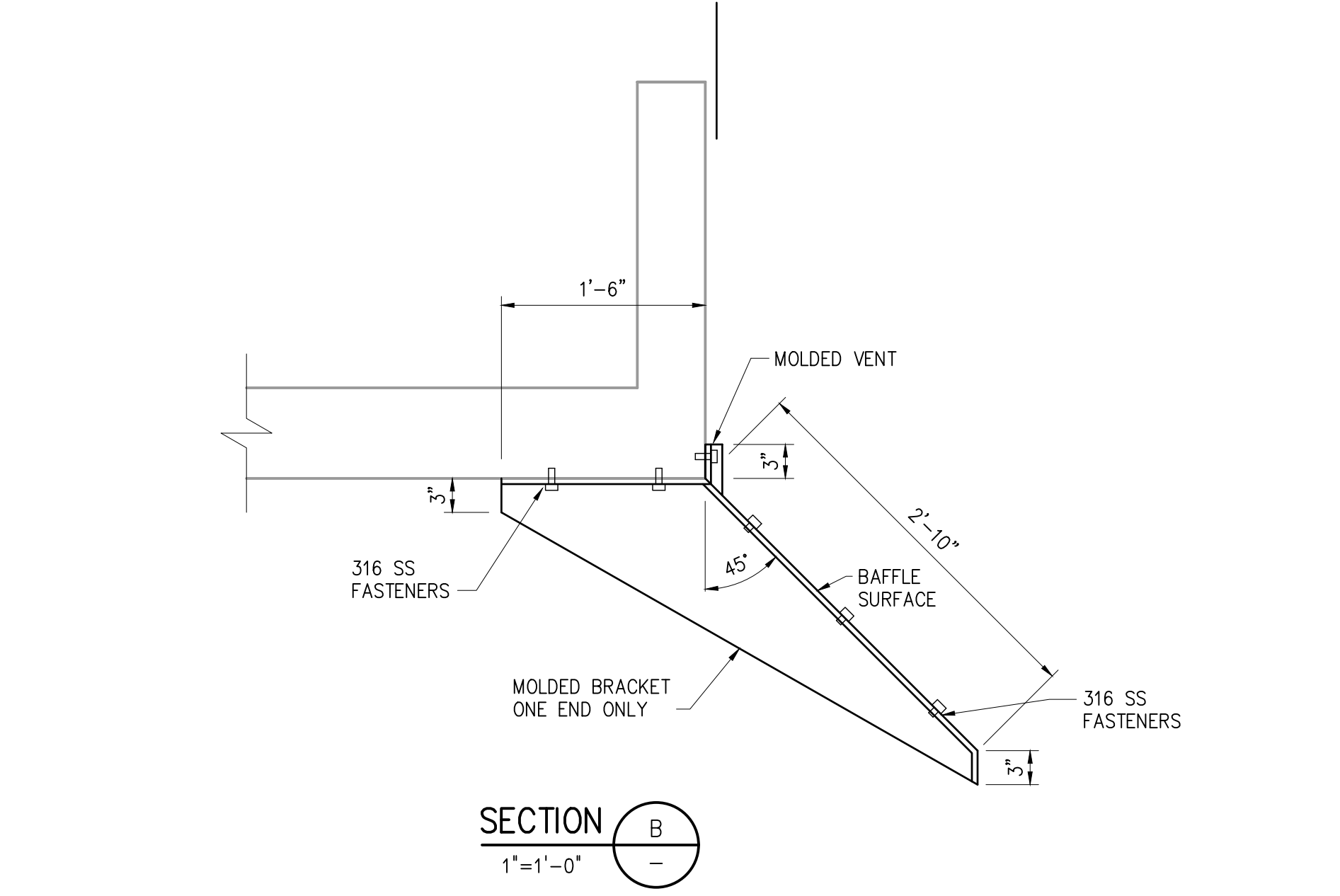
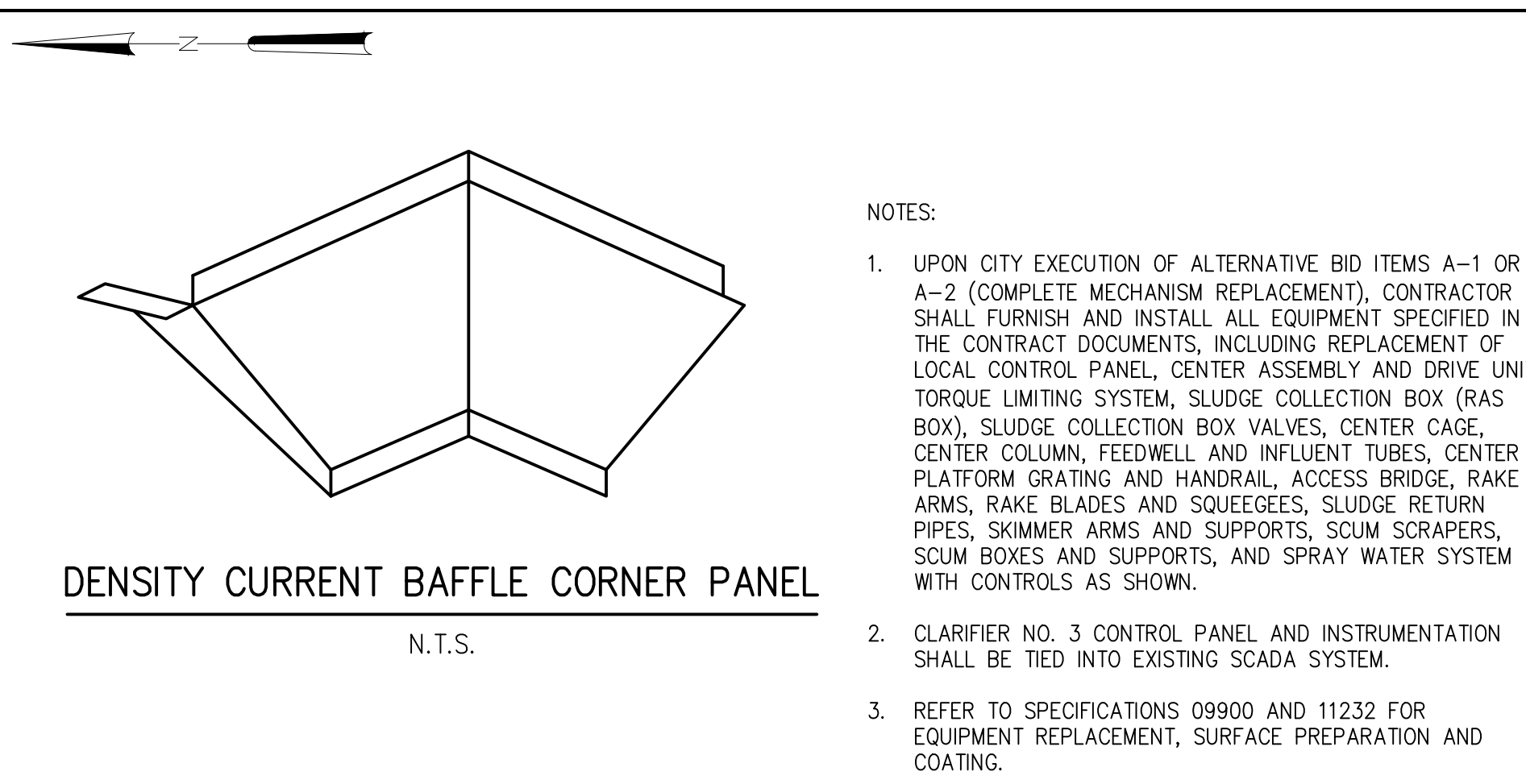
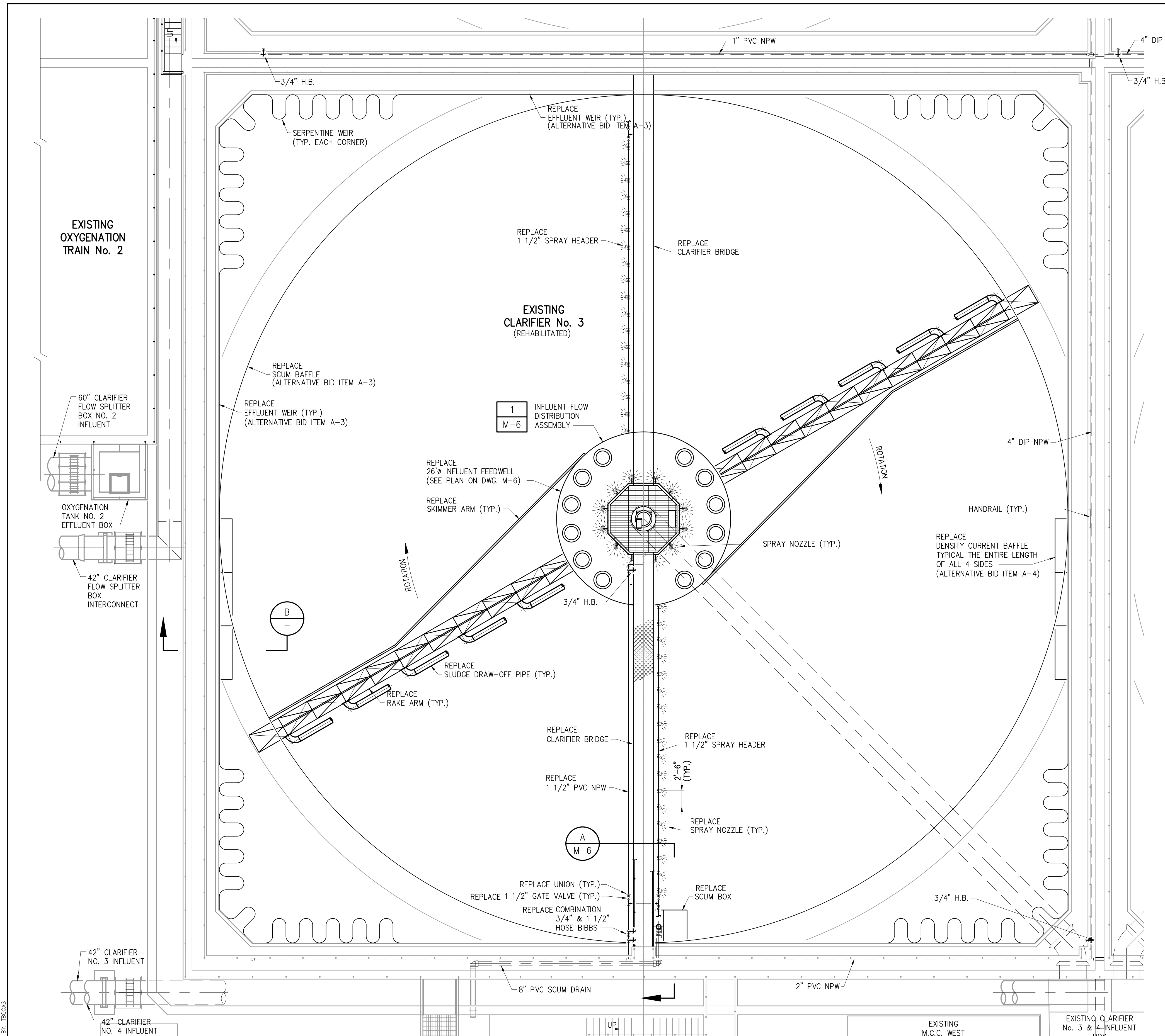

- NOTES:
- UPON CITY EXECUTION OF ALTERNATIVE BID ITEMS A-1 OR A-2 (COMPLETE MECHANISM REPLACEMENT), CONTRACTOR SHALL FURNISH AND INSTALL ALL EQUIPMENT SPECIFIED IN THE CONTRACT DOCUMENTS, INCLUDING REPLACEMENT OF LOCAL CONTROL PANEL, CENTER ASSEMBLY AND DRIVE UNIT, TORQUE LIMITING SYSTEM, SLUDGE COLLECTION BOX (RAS BOX), SLUDGE COLLECTION BOX VALVES, CENTER CAGE, CENTER COLUMN, FEEDWELL AND INFLUENT TUBES, CENTER PLATFORM GRATING AND HANDRAIL, ACCESS BRIDGE, RAKE ARMS, RAKE BLADES AND SQUEEGEES, SLUDGE RETURN PIPES, SKIMMER ARMS AND SUPPORTS, SCUM SCRAPERS, SCUM BOXES AND SUPPORTS, AND SPRAY WATER SYSTEM WITH CONTROLS AS SHOWN.
  - CLARIFIER NO. 3 CONTROL PANEL AND INSTRUMENTATION SHALL BE TIED INTO EXISTING SCADA SYSTEM.
  - REFER TO SPECIFICATIONS 09900 AND 11232 FOR EQUIPMENT REPLACEMENT, SURFACE PREPARATION AND COATING.

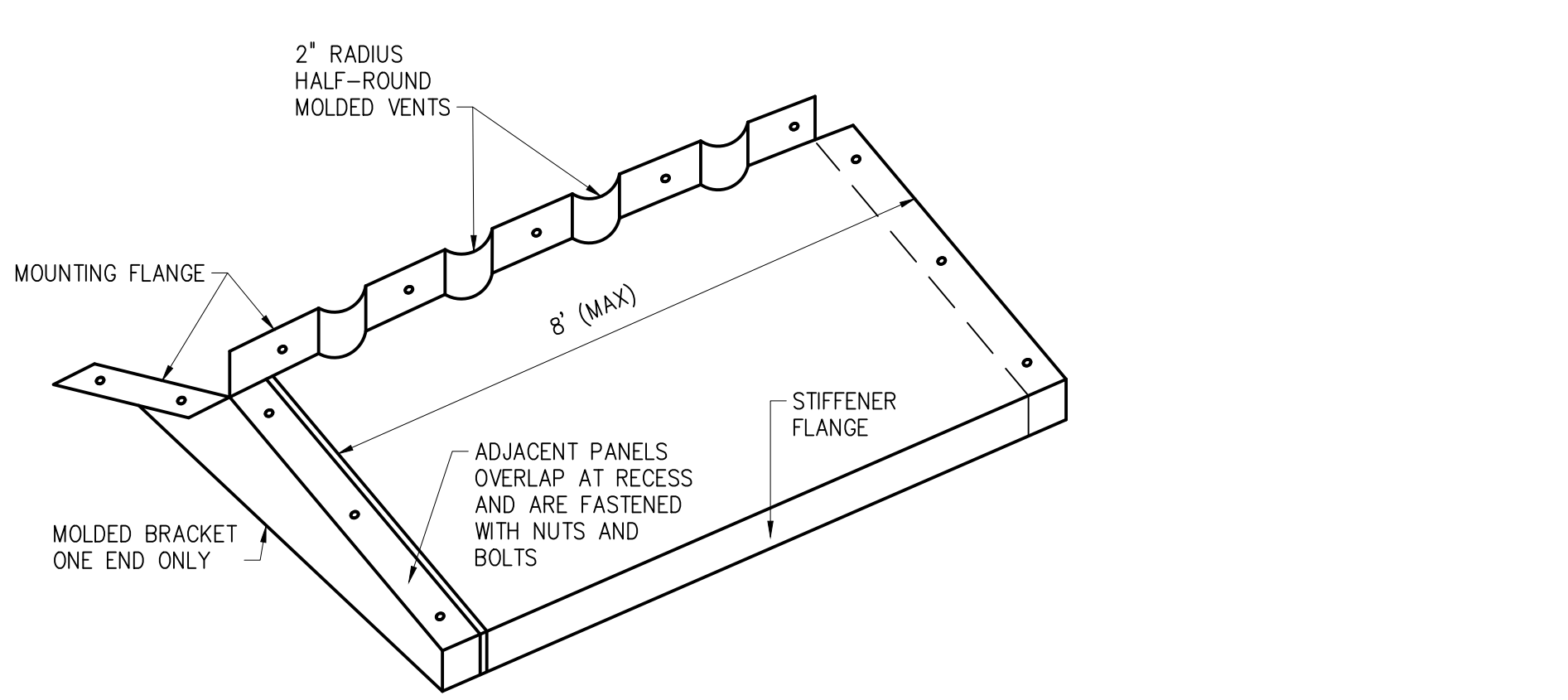

- LEGEND
- EXISTING FACILITY
- EQUIPMENT TO BE REPLACED
- NOTES:
- CLARIFIER No. 3 SHOWN.
  - REFER TO DRAWING M-3 FOR CLARIFIER REPAIR DETAILS.

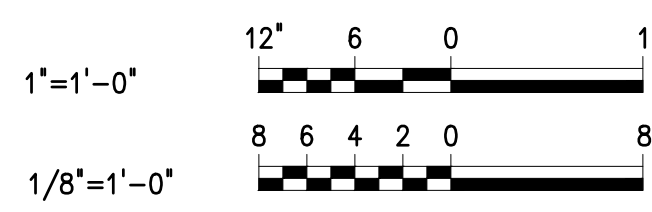

NO.	DATE	ISSUED FOR	BY

DESIGNED	TAV
DRAWN	TB
CHECKED	JPC
PROJ. ENGR.	TAV

J. PHILIP COOKE  
No. 47137

P.E.

**Hazen**

HAZEN AND SAWYER  
4000 HOLLYWOOD BOULEVARD, SUITE 750N  
HOLLYWOOD, FLORIDA 33021

THE SCALE BAR SHOWN BELOW MEASURES ONE INCH LONG ON THE ORIGINAL DRAWING.

CONTRACT: —

CLIENTS PROJECT: 22-9525

ENGINEERS PROJECT: 4321-095

CAD REFERENCE: 8242-095-M04

CITY OF HOLLYWOOD

SOUTHERN REGIONAL WASTEWATER TREATMENT PLANT

CLARIFIER No. 3 REPAIR

ALTERNATE BID ITEM A-1 THROUGH A-4  
CLARIFIER NO.3 REPLACEMENT - PLAN

DATE: JANUARY 2023

SHEET: 07 OF 17

DRAWING: M-4

BID SET

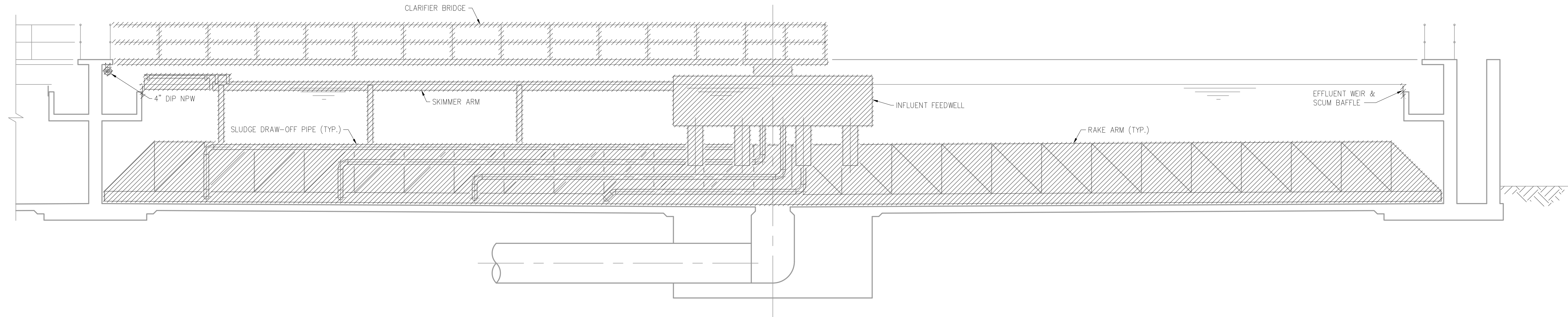

EQUIPMENT REMOVAL  
 ILLUSTRATIVE CROSS SECTION  
 3/16"=1'-0"

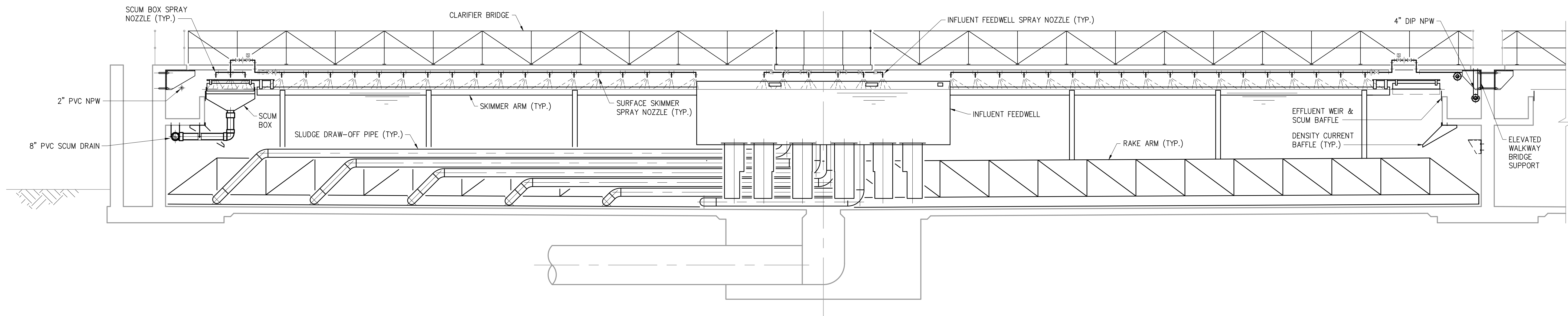

EQUIPMENT REPLACEMENT  
 ILLUSTRATIVE CROSS SECTION  
 3/16"=1'-0"

**LEGEND**

	EXISTING FACILITY
	TO BE REPLACED UPON CITY APPROVAL
	TO BE REMOVED



PLOT DATE: 1/5/2023 11:25 AM BY: TBCKAS

NO.	DATE	ISSUED FOR	BY

DESIGNED	TAV
DRAWN	TB
CHECKED	JPC
PROJ. ENGR.	TAV

J. PHILIP COOKE  
 No. 47137  
 P.E.

**Hazen**  
 HAZEN AND SAWYER  
 4000 HOLLYWOOD BOULEVARD, SUITE 750N  
 HOLLYWOOD, FLORIDA 33021

THE SCALE BAR SHOWN BELOW MEASURES ONE INCH LONG ON THE ORIGINAL DRAWING.

CONTRACT:	—
CLIENTS PROJECT:	22-9525
ENGINEERS PROJECT:	4321-095
CAD REFERENCE:	8242-095-M05

CITY OF HOLLYWOOD

SOUTHERN REGIONAL WASTEWATER TREATMENT PLANT  
 CLARIFIER No. 3 REPAIR  
**ALTERNATE BID ITEM A-1 THROUGH A-4**  
**CLARIFIER NO.3 REPLACEMENT - SECTIONS**

DATE:	JANUARY 2023
SHEET:	08 OF 17
DRAWING:	M-5

BID SET

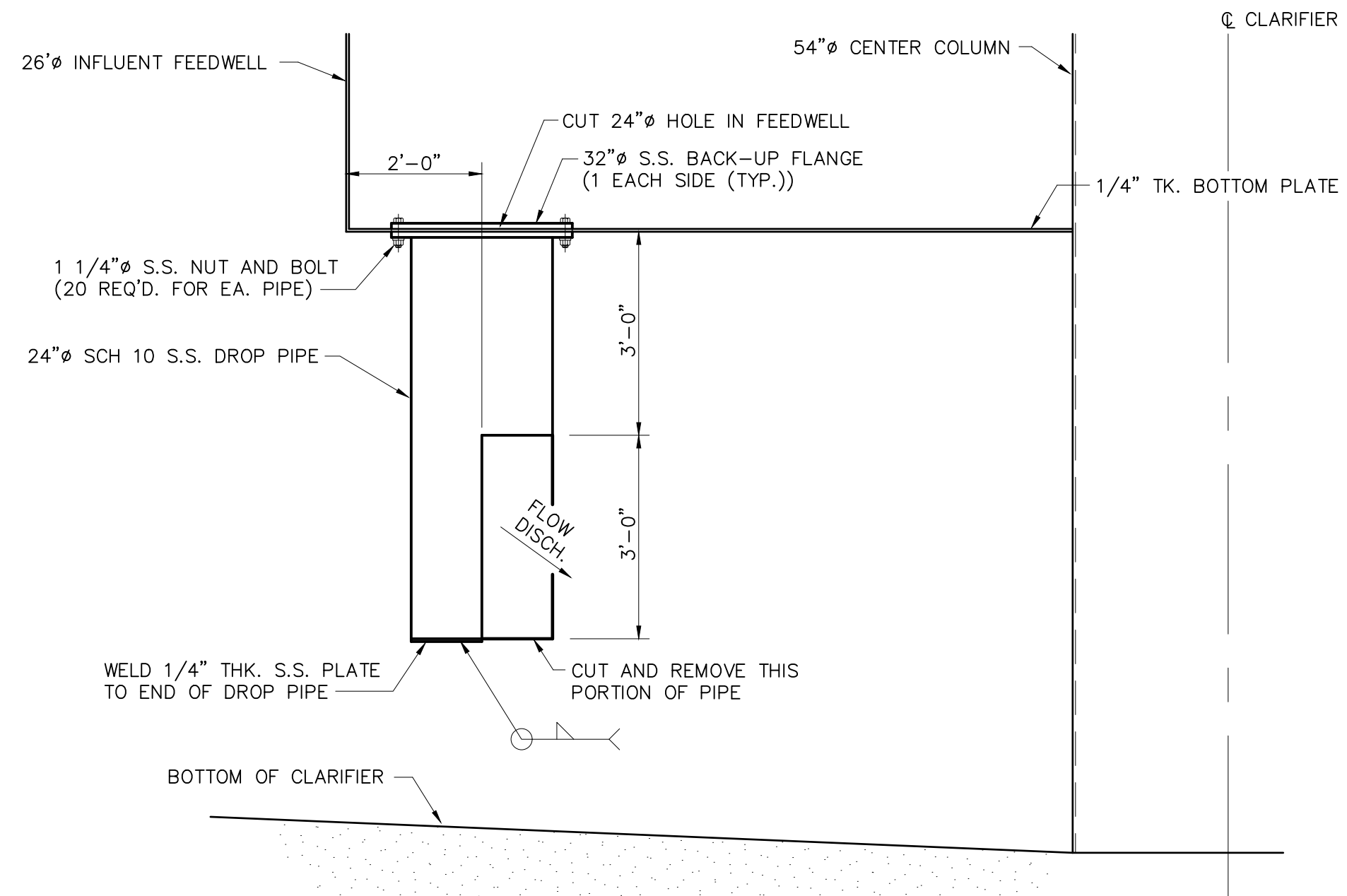

**ELEVATION**  
1/2"=1'-0"

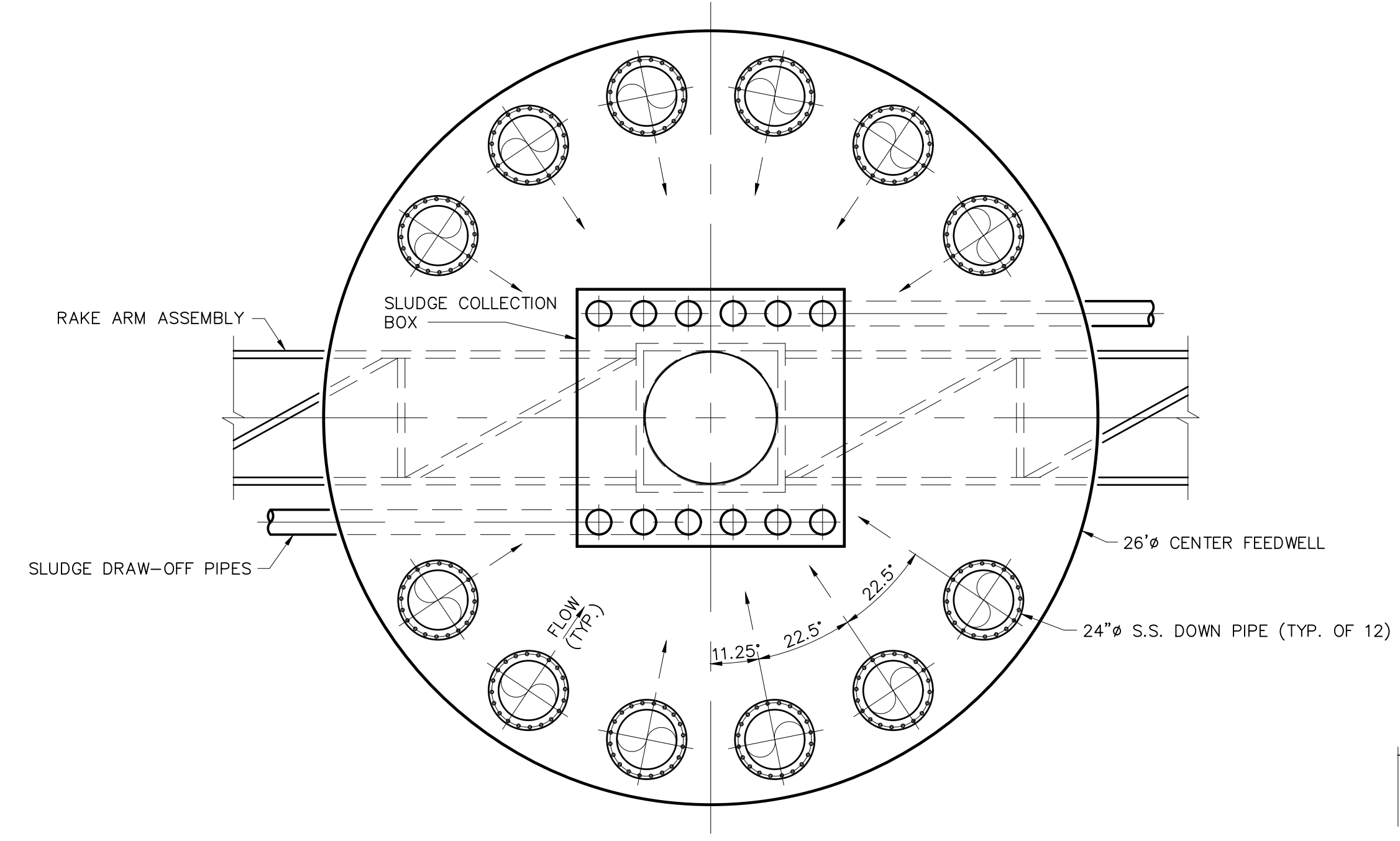

**PLAN**  
1/4"=1'-0"

- NOTE:  
 1. ALL NUTS, BOLTS AND HARDWARE TO BE 316 STAINLESS STEEL.  
 2. ALL PIPE TO BE SCH. 10S 316 STAINLESS STEEL, ASTM A-240, U.S.S. GAUGE 3/16 (.187") (ALTERNATIVE BID ITEM A-2)

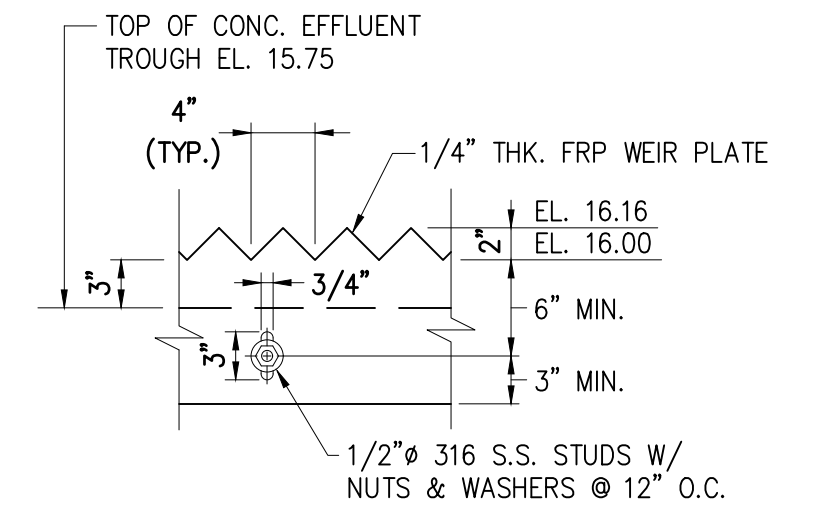

**V-NOTCH EFFLUENT WEIR**  
1"=1'-0"

**INFLUENT FLOW DISTRIBUTION ASSEMBLY**  
1  
M-4

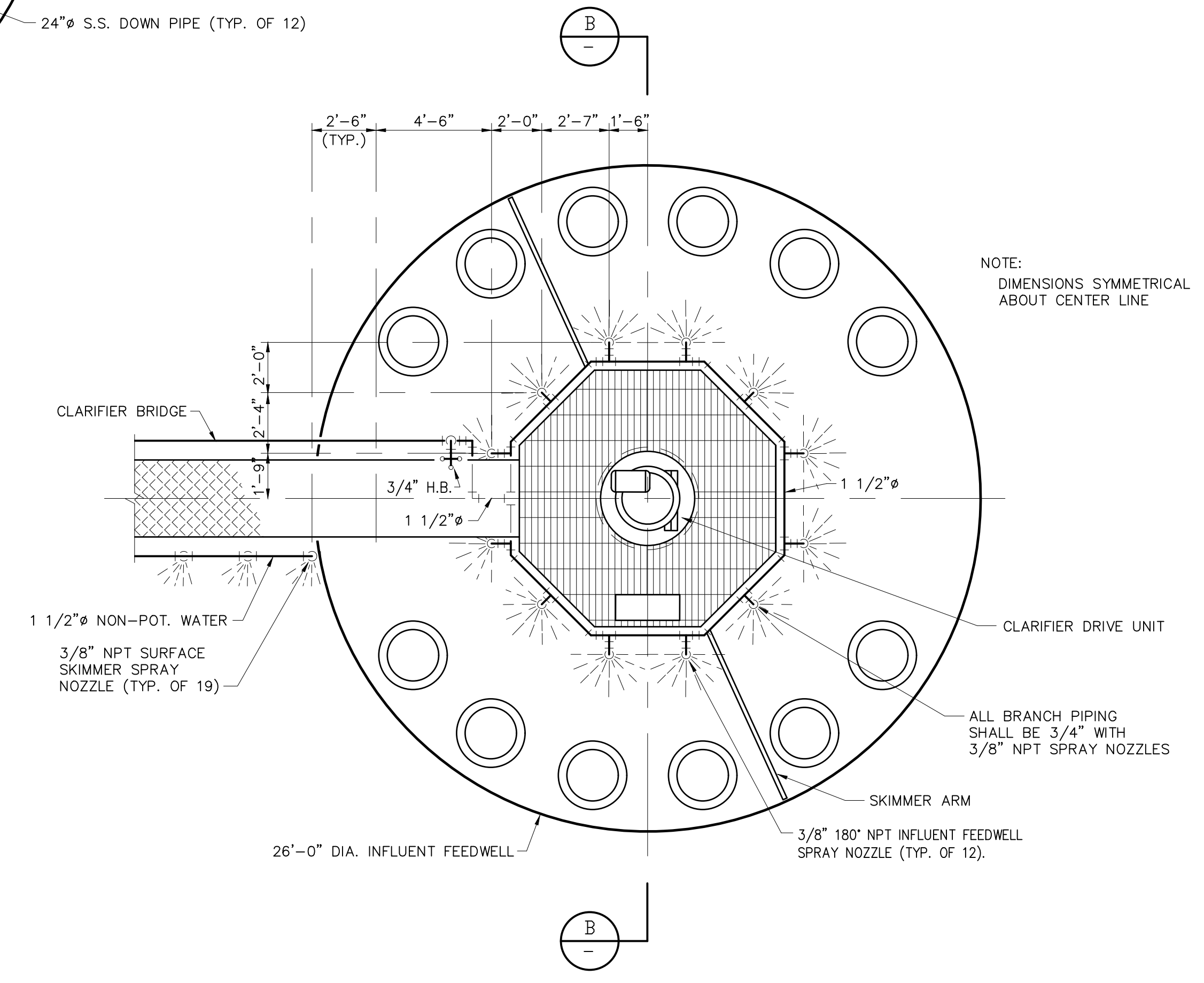

**INFLUENT FEEDWELL PLAN**  
1/4"=1'-0"

NOTE:  
DIMENSIONS SYMMETRICAL ABOUT CENTER LINE

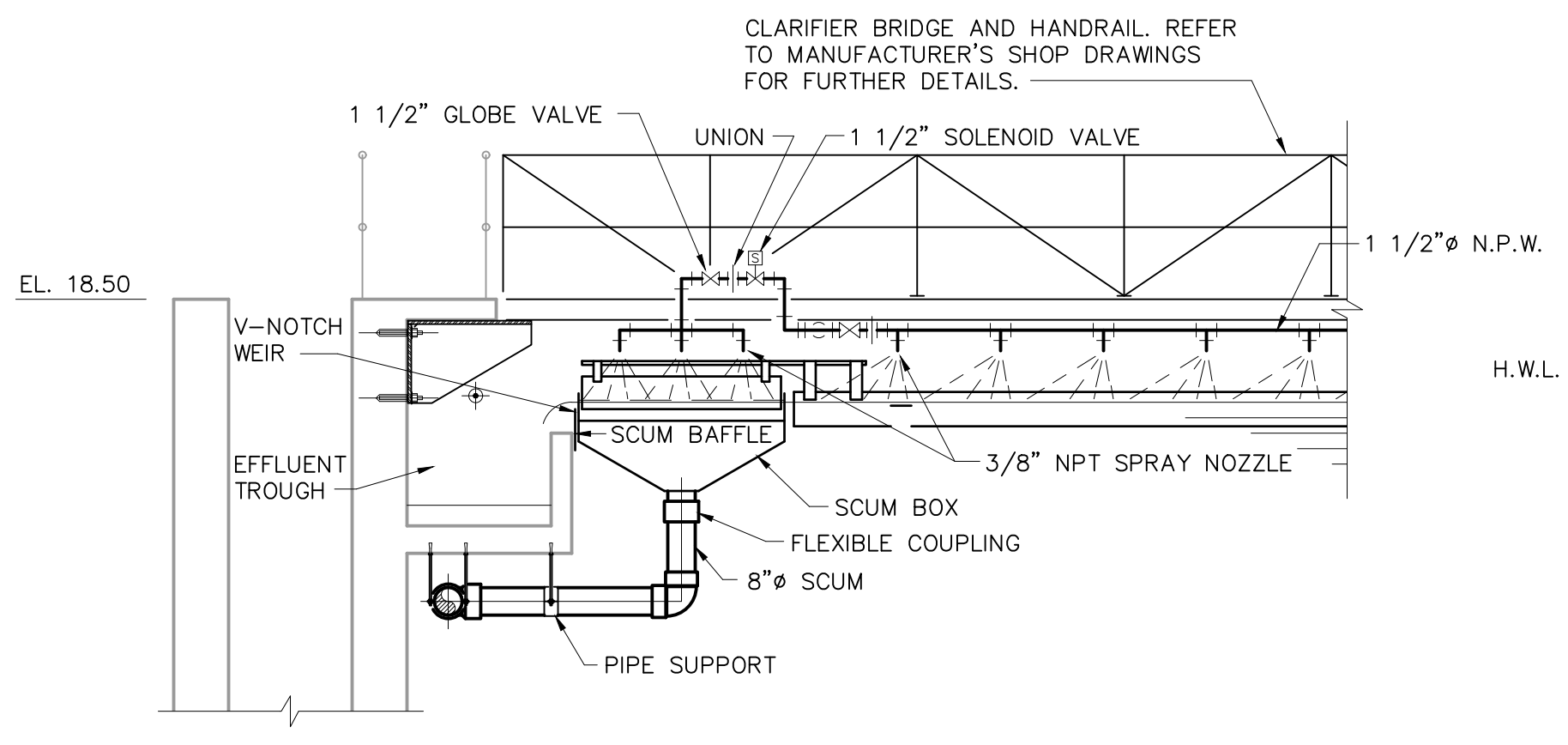

**SECTION A**  
1/4"=1'-0" M-4

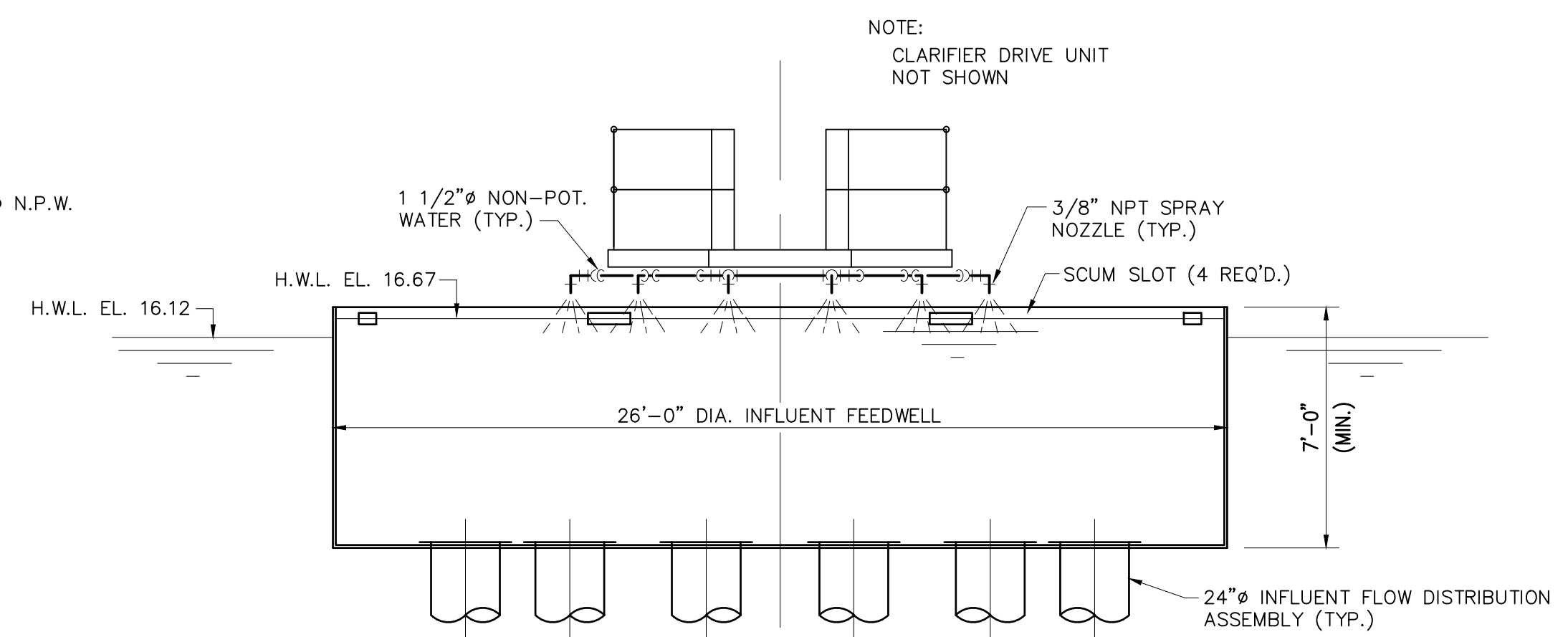

**SECTION B**  
1/4"=1'-0"

NOTE:  
CLARIFIER DRIVE UNIT NOT SHOWN

**LEGEND**

— EXISTING FACILITY  
 — EQUIPMENT TO BE REPLACED

1"=1'-0"

1/4"=1'-0"

3/16"=1'-0"

PLOT DATE: 1/5/2023 11:29 AM BY: TBOCAS

DESIGNED	TAV		
DRAWN	TB		
CHECKED	JPC		
PROJ. ENGR.	TAV		
NO.	DATE	ISSUED FOR	BY

J. PHILIP COOKE  
No. 47137  
P.E.

**Hazen**  
HAZEN AND SAWYER  
4000 HOLLYWOOD BOULEVARD, SUITE 750N  
HOLLYWOOD, FLORIDA 33021

THE SCALE BAR SHOWN BELOW MEASURES ONE INCH LONG ON THE ORIGINAL DRAWING.

CONTRACT: —  
 CLIENTS PROJECT: 22-9525  
 ENGINEERS PROJECT: 4321-095  
 CAD REFERENCE: 8242-095-M06



CITY OF HOLLYWOOD

SOUTHERN REGIONAL WASTEWATER TREATMENT PLANT  
 CLARIFIER No. 3 REPAIR  
 ALTERNATE BID ITEMS A-1 THROUGH A-4  
 CLARIFIER NO.3 REPLACEMENT - DETAILS

DATE: JANUARY 2023  
 SHEET: 09 OF 17  
 DRAWING: M-6

BID SET

<b>BASIC ELECTRICAL REQUIREMENTS:</b>	
<b>1.0</b>	<b>Scope of work</b>
1.1	THE SCOPE OF WORK SHALL BE AS DESCRIBED IN SPECIFICATION SECTION 16010.
1.2	THE CONTRACTOR SHALL OBTAIN ALL NECESSARY PERMITS, INSPECTIONS AND APPROVALS AND TO INCLUDE ALL FEES AS PART OF HIS BID IF NOT OTHERWISE NOTED.
1.3	THE CONTRACTOR SHALL, BEFORE SUBMITTING HIS BID, VISIT THE SITE OF THE PROJECT AND BECOME FAMILIAR WITH THE EXISTING CONDITIONS. NO ALLOWANCE WILL BE MADE FOR EXISTING CONDITIONS OR FAILURE OF THE CONTRACTOR TO OBSERVE THEM.
1.4	IT IS THE CONTRACTOR'S RESPONSIBILITY TO COORDINATE WITH ALL LOCAL UTILITIES, INCLUDING THE POWER AND TELEPHONE UTILITIES TO MEET ALL OF THEIR INSTALLATION REQUIREMENTS. ALL FEES, LABOR, EQUIPMENT OR MATERIALS NECESSARY TO MEET THESE REQUIREMENTS IS TO BE INCLUDED IN THE BID. THE CONTRACTOR SHALL OBTAIN, DELIVER AND INSTALL ALL CONDUITS, PULL-BOXES AND EQUIPMENT AS REQUIRED BY THE UTILITIES TO THEIR SPECIFICATIONS. THE TELEPHONE UTILITY REPRESENTATIVE IS THE CITY'S TELEPHONE CONTRACTOR.
1.5	THE CONTRACTOR SHALL COORDINATE HIS WORK WITH THE ENGINEER AND OWNER.
1.6	THE CONTRACTOR SHALL PROVIDE ALL MATERIALS AND LABOR TO INSTALL THE ELECTRICAL SYSTEMS AS INDICATED ON THE DRAWINGS. ITEMS NOT SHOWN BUT OBVIOUSLY NECESSARY FOR COMPLETION OF THE WORK SHALL BE INCLUDED.
1.7	ALL EQUIPMENT AND MATERIAL SHALL BE NEW, UNUSED AND U.L. LISTED. ALL REFERENCES TO A PARTICULAR MANUFACTURER ARE GIVEN ON AN "APPROVED EQUAL" BASIS.
1.8	THE CONTRACTOR IS RESPONSIBLE TO TEST ALL SYSTEMS INSTALLED OR MODIFIED UNDER THIS PROJECT AND REPAIR OR REPLACE ALL DEFECTIVE WORK TO THE SATISFACTION OF THE ENGINEER AND OWNER.
1.9	ALL EQUIPMENT FURNISHED AND INSTALLED BY THE CONTRACTOR SHALL BE GUARANTEED AGAINST DEFECTS IN MATERIAL AND WORKMANSHIP FOR A PERIOD OF ONE YEAR FROM DATE OF ACCEPTANCE UNLESS OTHERWISE NOTED.
1.10	SHOP DRAWINGS SHALL BE SUBMITTED FOR ALL ELECTRICAL & CONTROL EQUIPMENT AND MATERIAL.
<b>2.0</b>	<b>Codes and standards</b>
2.1	THE INSTALLATION SHALL BE IN ACCORDANCE WITH THE MINIMUM FOLLOWING STANDARDS AND CODES:
2.2	NATIONAL FIRE PROTECTION ASSOCIATION (NFPA)
2.3	NATIONAL ELECTRICAL CODE (NEC), (NFPA 70 LATEST EDITION)
2.4	NATIONAL ELECTRICAL SAFETY CODE, (NFPA 70E LATEST EDITION)
2.5	STANDARD FOR FIRE PROTECTION IN WASTEWATER TREATMENT AND COLLECTION FACILITIES, (NFPA 820 LATEST EDITION)
2.6	OTHER NFPA CODES AS APPLICABLE
2.7	FLORIDA BUILDING CODE (FBC LATEST EDITION)
2.8	LOCAL CODES, CITY CODES REQUIRED BY THE AUTHORITY HAVING JURISDICTION.
2.9	AMERICAN NATIONAL STANDARDS INSTITUTE (ANSI)
2.10	NATIONAL ELECTRICAL MANUFACTURERS ASSOCIATION (NEMA)
2.11	INSTITUTE OF ELECTRICAL AND ELECTRONIC ENGINEERS (IEEE)
2.12	INSULATED CABLE ENGINEERS ASSOCIATION (ICEA)
2.13	OCCUPATIONAL SAFETY AND HEALTH ACT (OSHA)
2.14	AMERICAN SOCIETY FOR TESTING AND MATERIALS (ASTM)
2.15	UNDERWRITERS LABORATORIES (UL) LISTING AND LABELING FOR ALL MATERIALS AND EQUIPMENT WHERE APPLICABLE STANDARDS EXIST
<b>3.0</b>	<b>General Items</b>
3.1	ALL CIRCUITS SHALL BE IDENTIFIED IN JUNCTION BOXES, PULL BOXES, CONTROL PANELS, PANELBOARDS, LIGHTING POLES, CONTROLLERS AND SERVICE POINTS. IDENTIFICATION SHALL MATCH PANELBOARD SCHEDULES.
3.2	ALL LOCATIONS OF EQUIPMENT, PANELS ETC. ARE SHOWN FOR ILLUSTRATION PURPOSES. CONTRACTOR SHALL VERIFY AND COORDINATE EXACT LOCATION AND SIZE WITH ALL SUBCONTRACTORS AND EQUIPMENT SUPPLIERS PRIOR TO ANY INSTALLATION AND THEN INSTALL AS SUCH WITH CORRESPONDING CONDUIT STUB-UPS.

3.3	SEE OTHER DISCIPLINE DRAWINGS FOR COORDINATION OF ALL DRAWINGS. ANY CONFLICTS SHALL BE BROUGHT TO THE ENGINEER'S ATTENTION AND MOVEMENT OF CONDUITS OR OTHER ELECTRICAL EQUIPMENT SHALL BE ACCOMPLISHED WITHOUT ANY ADDITIONAL COST FOR THE OWNER.								
3.4	THE CONTRACTOR SHALL BE RESPONSIBLE FOR ALL CONDUIT AND WIRING INSTALLATION FOR ALL VENDOR PROVIDED EQUIPMENT (PACKAGE SYSTEMS). IF THE SHOP DRAWINGS DIFFER FROM THE DESIGNED FACILITIES, THE CONTRACTOR SHALL REDESIGN THE FACILITIES AND SUBMIT THE REVISED DESIGN FOR THE ENGINEER'S APPROVAL ALONG WITH THE SHOP DRAWINGS. THERE SHALL BE NO ADDITIONAL COST TO THE OWNER FOR THE REDESIGN NOR FOR ANY ADDITIONAL CONDUITS AND WIRING. DURING SUBMITTAL THE CONTRACTOR SHALL VERIFY ALL SUPPLIED BREAKER SIZES FOR ALL PACKAGED SYSTEMS SUCH AS HVAC, EXHAUST FANS, MIXERS, CHEMICAL PUMPS ETC. AND MODIFY ALL BREAKERS IN MCC'S AND PANELBOARDS ACCORDINGLY WITHOUT ANY ADDITIONAL COST TO THE OWNER.								
3.5	CONTRACTOR SHALL RESTORE SIDEWALKS, ROADWAYS, SOD AND SPRINKLER SYSTEM PIPING TO MATCH EXISTING, AFTER THE COMPLETION OF THE CONDUIT AND PULLBOX INSTALLATION.								
3.6	ELECTRICAL EQUIPMENT SHALL BE DEFINED AS ANY ELECTRICAL DEVICE USED IN CONJUNCTION WITH OTHER EQUIPMENT REQUIRING ELECTRICITY FOR OPERATION. THIS INCLUDES BUT IS NOT LIMITED TO: DISCONNECT SWITCHES, JUNCTION BOXES, PANELBOARDS, TRANSFORMERS, LIGHTING FIXTURES, MOTOR STARTERS, SWITCHGEAR, MOTOR CONTROL CENTERS, CONTROLS, LOCAL CONTROL PANELS.								
3.7	ALL REFERENCES TO STAINLESS STEEL (SS) SHALL MEAN TYPE 316 STAINLESS STEEL UNLESS OTHERWISE NOTED.								
3.8	ALL ELECTRICAL EQUIPMENT IN DESIGNATED CORROSIVE AREAS SHALL BE NEMA 4X 316 STAINLESS STEEL OR NON-METALLIC (FRP).								
3.9	OUTDOOR LIGHTING FIXTURES SHALL BE COPPER FREE ALUMINUM.								
3.10	CONTRACTOR SHALL PROVIDE AS PART OF THE ELECTRICAL SUBMITTAL, A LAYOUT OF THE ELECTRICAL ROOM SHOWING SIZES OF ALL EQUIPMENT INCLUDING LIGHTING, AND HVAC WITH THEIR SPATIAL RELATIONSHIPS.								
3.11	CONTRACTOR SHALL PROVIDE AND INSTALL WIRE ID TAGS ON ALL WIRING THAT INTERFACES WITH OTHER EQUIPMENT.								
<b>4.0</b>	<b>Operation and maintenance manuals</b>								
4.1	CONTRACTOR SHALL PROVIDE AN OPERATION AND MAINTENANCE MANUAL PER FBC EC C405.7.4.2 INCLUDING: 1. SUBMITTAL DATA STATING EQUIPMENT RATING AND SELECTED OPTION FOR EACH PIECE OF EQUIPMENT REQUIRING MAINTENANCE. 2. OPERATION AND MAINTENANCE MANUALS FOR EACH PIECE OF EQUIPMENT REQUIRING MAINTENANCE. REQUIRED ROUTINE MAINTENANCE ACTIONS SHALL BE CLEARLY IDENTIFIED 3. NAMES AND ADDRESSES OF AT LEAST ONE QUALIFIED SERVICE AGENCY								
4.2	SEE SPECIFICATIONS FOR ADDITIONAL DETAILS								
<b>5.0</b>	<b>Project closeout</b>								
5.1	CONTRACTOR SHALL PROVIDE RECORD DRAWINGS TO THE OWNER AND ENGINEER WITHIN 30 DAYS OF ACCEPTANCE.								
5.2	N/A								
5.3	N/A								
<b>6.0</b>	<b>Raceways:</b>								
6.1	CONDUITS RUN IN PARALLEL: INSTRUMENTATION CONDUITS SHALL HAVE A MINIMUM SEPARATION FROM POWER CONDUITS AS INDICATED IN TABLE WHETHER CONCRETE ENCASED DUCT BANKS, DIRECT BURIED, SURFACE OR RACKS: <table border="1" style="margin-left: 20px;"> <thead> <tr> <th>VOLTAGE</th> <th>DISTANCE</th> </tr> </thead> <tbody> <tr> <td>4160V</td> <td>3 FT</td> </tr> <tr> <td>480V</td> <td>2 FT</td> </tr> <tr> <td>120V</td> <td>1 FT</td> </tr> </tbody> </table>	VOLTAGE	DISTANCE	4160V	3 FT	480V	2 FT	120V	1 FT
VOLTAGE	DISTANCE								
4160V	3 FT								
480V	2 FT								
120V	1 FT								
6.2	NOT ALL CONDUITS SHOWN ON RISER AND ONE-LINE DIAGRAMS ARE SHOWN ON BUILDING LAYOUTS. CONTRACTOR SHALL SUPPLY ALL CONDUITS AND CABLES AS SHOWN ON RISERS AND ONE-LINE DIAGRAMS.								

6.3	EXPOSED RUNS OF CONDUITS SHALL BE INSTALLED WITH RUNS PARALLEL OR PERPENDICULAR TO WALLS, STRUCTURAL MEMBERS OR INTERSECTIONS OF VERTICAL PLANES AND CEILINGS, WITH RIGHT ANGLE TURNS CONSISTING OF SYMMETRICAL BENDS OR PULL BOXES AS INDICATED ON THE DRAWINGS. BENDS AND OFFSETS SHALL BE AVOIDED WHERE POSSIBLE.
6.4	THE DRAWINGS ARE NOT INTENDED TO SHOW THE EXACT LOCATION OF CONDUIT RUNS. THESE ARE TO BE COORDINATED WITH THE OTHER TRADES SO THAT CONFLICTS ARE AVOIDED PRIOR TO INSTALLATIONS.
6.5	CONTRACTOR SHALL CORE DRILL EXISTING CONCRETE WALLS, FLOORS, MANHOLES, HAND HOLES AND PULL BOXES FOR CONDUIT PENETRATIONS. SEAL PENETRATIONS WITH NON-SHRINK GROUT OR APPROPRIATE FIRE RATED DEVICES WHERE APPLICABLE.
6.6	ALL CONDUITS PENETRATING RATED FIRE WALLS OR RATED FIRE FLOORS SHALL BE INSTALLED WITH U.L. APPROVED DEVICES AND OR FIRE RATED SEALING COMPOUND TO MAINTAIN THE FIRE RATING OF THE WALL OR FLOOR PENETRATED.
6.7	PROVIDE CONDUIT DUCT SEAL AT ALL CONDUIT ENDS.
6.8	ALL SPARE, ABANDONED, OR EMPTY CONDUITS SHALL BE SEALED WITH A CAP AT BOTH ENDS AND A PULL STRING INSTALLED WITH IDENTIFICATION OF OTHER END LOCATION AT BOTH ENDS.
6.9	FLEXIBLE CONDUITS SHALL BE USED TO TERMINATE ALL MOTORS AND OTHER VIBRATING EQUIPMENT AND SHALL BE BETWEEN 18" AND 36" IN LENGTH.
6.10	ALL METALLIC CONDUITS BELOW GRADE TO A MINIMUM ELEVATION OF 12 INCHES ABOVE GRADE SHALL BE PVC COATED RIGID METAL CONDUIT (RMC).
6.11	ALL METALLIC CONDUITS 12 INCHES AND GREATER ABOVE GRADE SHALL BE RMC.
6.12	ALL REFERENCES TO RMC SHALL MEAN RIGID GALVANIZED STEEL CONDUIT (RGS) UNLESS OTHERWISE NOTED.
6.13	ALL REFERENCES TO PVC COATED RMC SHALL MEAN PVC COATED RIGID GALVANIZED STEEL CONDUIT (RGS) UNLESS OTHERWISE NOTED.
6.14	ALUMINUM CONDUIT SHALL NOT BE USED FOR INSTRUMENTATION WIRING.
<b>7.0</b>	<b>Duct Banks &amp; Manholes</b>
7.1	LOCATIONS OF MANHOLES, HANDHOLES AND PULL BOXES ARE APPROXIMATE. CONTRACTOR SHALL COORDINATE EXACT LOCATION WITH EXISTING AND NEW PIPING OR CONDUIT AND ADJUST ACCORDINGLY.
7.2	COLOR WARNING TAPE 6" WIDE SHALL BE INSTALLED 8" BELOW FINISHED GRADE DIRECTLY ABOVE ALL UNDERGROUND YARD CONDUITS ACCORDING TO THE FOLLOWING SCHEDULE: POWER: RED
7.3	POWER: RED
7.4	ALL OTHER CONDUITS: GREEN
7.5	ALL EXCAVATIONS FOR CONDUITS, HANDHOLES, MANHOLES AND PULLBOXES NEAR EXISTING PIPING, CONDUIT AND EQUIPMENT SHALL BE HAND EXCAVATED AND COORDINATED WITH PLANT ENGINEER.
7.6	MINIMUM DEPTH FROM TOP OF DUCT BANKS OR CONDUITS TO FINISHED GRADE SHALL BE 24" UNLESS OTHERWISE NOTED.
7.7	IF CONCRETE ENCASED DUCT BANKS INCLUDE POWER WITH ANY TYPE OF SIGNALS EXCEPT FIBER OPTIC CABLE, ALL CONDUITS SHALL BE METALLIC.
7.8	CONCRETE DUCT BANKS WITH POWER ONLY WIRING MAY BE PVC UNLESS OTHERWISE NOTED ON THE DRAWINGS.
7.9	SLOPE DUCT BANKS A MINIMUM 3 INCHES PER 100 FEET DOWN AWAY FROM BUILDINGS.
7.10	DUCT BANK CONCRETE SHALL BE MINIMUM CLASS C 2500 PSI
<b>8.0</b>	<b>Conductors:</b>
8.1	ALUMINUM CONDUCTORS SHALL NOT BE USED FOR THIS PROJECT.
8.2	CONDUCTOR PULLING TENSIONS SHALL NOT EXCEED MANUFACTURER'S RECOMMENDATION. CONTRACTOR SHALL INSTALL PULL BOXES TO MEET MANUFACTURER'S REQUIREMENTS.
8.3	COPPER CONDUCTORS FOR POWER WIRING WITH A VOLTAGE GREATER THAN 240V TO GROUND SHALL BE XHHW-2. OTHER POWER WIRING SHALL BE EITHER XHHW OR THWN STRANDED COPPER WIRING.
8.4	BRANCH CIRCUITS EXCEEDING 100 FT IN LENGTH SHALL BE WIRED WITH MINIMUM #10 AWG COPPER WIRES. CONTRACTOR SHALL VERIFY REQUIRED WIRE SIZE WITH VOLTAGE DROP CALCULATIONS.
<b>9.0</b>	<b>Boxes</b>
9.1	ALL ENCLOSURES, TJB, WIREWAY, PULL BOXES ETC. SHALL CONTAIN A GROUNDING BUS. CONNECT ALL RACEWAY BONDS TO THIS BUS VIA GROUNDING BUSHING AND EXTEND BONDING JUMPER FROM THIS BUS TO THE ENCLOSURE.

9.2	ALL JUNCTIONS BOXES, LOCAL CONTROL PANELS, DISCONNECT SWITCHES AND INSTALLATION HARDWARE INSTALLED OUTDOORS SHALL BE 316 STEEL.
<b>10.0</b>	<b>Panels</b>
10.1	ALL CONTROL PANELS SHALL BE CONSTRUCTED BY A UL 508A APPROVED PANEL VENDOR AND SHALL BEAR A UL 508A LABEL ON THE PANEL.
10.2	TYPEWRITTEN AND LAMINATED PANEL SCHEDULES SHALL BE INSTALLED IN EACH PANELBOARD, AND TYPEWRITTEN TERMINAL BLOCK SCHEDULES IN EACH CONTROL CABINET.
10.3	ALL PANELBOARDS SHALL INCLUDE AN INTEGRAL FACTORY INSTALLED SURGE PROTECTION DEVICES (SPD AKA TVSS).
10.4	CONTRACTOR SHALL BALANCE PANELBOARD LOADS AT THE END OF THE PROJECT.
<b>11.0</b>	<b>Grounding</b>
11.1	GROUNDING SHALL BE INSTALLED IN ACCORDANCE WITH NEC, ARTICLE 250. THE GROUNDING SYSTEM TEST SHALL NOT EXCEED A 48 HOUR SPAN DRY RESISTANCE OF 10 OHMS. ADDITIONAL GROUNDING TO MEET THIS REQUIREMENT SHALL BE INSTALLED AT NO EXTRA COST. GROUNDING AND BONDING CONNECTIONS SHALL NOT BE PAINTED. ALL GROUNDING CONNECTIONS SHALL BE EXOTHERMIC UNLESS SPECIFICALLY INDICATED OTHERWISE.
11.2	AN EQUIPMENT GROUND WIRE SIZED PER NEC SHALL BE PULLED IN ALL ELECTRICAL CONDUITS, POWER AND CONTROL, WHETHER OR NOT INDICATED ON THE PLANS.
<b>12.0</b>	<b>Instrumentation</b>
12.1	INSTRUMENTATION IS LOW VOLTAGE SIGNALS SUCH AS 4-20MA, TELEPHONE COMMUNICATION, FIRE ALARM COMMUNICATION. POWER CONDUITS SHALL ONLY CROSS INSTRUMENTATION CONDUIT PERPENDICULARLY AT RIGHT ANGLES WITH 6" SEPARATION.
12.2	THE POWER AND SIGNAL SIDES OF ALL EXTERIOR INSTALLED INSTRUMENTATION SHALL HAVE SURGE PROTECTION AND SHALL BE GROUNDED TO A SEPARATE GROUND ROD AT THE INSTRUMENT.
12.3	INSTRUMENTATION GROUND SHALL BE A #6 AWG COPPER CONNECTED TO THE GROUND GRID OR CONNECTED TO A DRIVEN GROUND. #6 GROUND WIRE SHALL BE INSTALLED IN CONDUIT WHERE EXPOSED. GROUND RODS SHALL BE 5/8" OR 3/4" BY A MINIMUM OF 20' IN LENGTH, AS INDICATED ON THE DRAWINGS.
12.4	CONTRACTOR SHALL INSTALL A SWITCH TO DISCONNECT POWER AT EACH FOUR WIRE INSTRUMENT.
12.5	ALL INSTRUMENTATION WIRING SHALL BE TERMINATED, LOOP TESTED LOCALLY AND BETWEEN THE BASE STATION AND LOCAL PUMP STATION PRIOR TO FINAL STARTUP AND ACCEPTANCE.
<b>13.0</b>	<b>Signage</b>
13.1	CONTRACTOR SHALL PROVIDE SIGNAGE PER NEC 110.24 AND NEC 702.7 AT THE SERVICE ENTRANCE EQUIPMENT.
13.2	CONTRACTOR SHALL PROVIDE SIGNAGE PER NFPA 110 FOR THE EMERGENCY SHUT-OFF BUTTON LOCATED ON THE NORTH EAST OUTSIDE CORNER OF THE ELECTRICAL BUILDING.
13.3	CONTRACTOR SHALL PROVIDE SIGNAGE PER NFPA 704 AS NECESSARY.
13.4	CONTRACTOR SHALL PROVIDE AND INSTALL ARC-FLASH HAZARD WARNING LABELS PER NEC 110.16 AND 110.21. THESE RULES APPLY AS A MINIMUM TO SWITCHBOARDS, SWITCHGEAR, PANELBOARDS, MOTOR CONTROL CENTERS, INDUSTRIAL CONTROL PANELS, METER SOCKET ENCLOSURES, AND ENCLOSED CIRCUIT BREAKERS.
<b>14.0</b>	<b>Electrical devices</b>
14.1	ALL RECEPTACLES SHALL BE INSTALLED 18" AFF UNLESS OTHERWISE NOTED. LIGHT SWITCHES SHALL BE MOUNTED 48" AFF UNLESS OTHERWISE NOTED.
14.2	ALL RECEPTACLES WITHIN 6' OF A SINK SHALL BE GFI.

PLOT DATE: 1/5/2023 11:29 AM BY: TBODAS

DESIGNED	JMB		
DRAWN	JMB		
CHECKED	JCB		
PROJ. ENGR.	TAV		
NO.	DATE	ISSUED FOR	BY

DESIGNED	JMB
DRAWN	JMB
CHECKED	JCB
PROJ. ENGR.	TAV

JOHN C. BURKE	P.E.
No. 17301	

**Hazen**  
HAZEN AND SAWYER  
4000 HOLLYWOOD BOULEVARD, SUITE 750N  
HOLLYWOOD, FLORIDA 33021

THE SCALE BAR SHOWN BELOW MEASURES ONE INCH LONG ON THE ORIGINAL DRAWING.

CONTRACT:	—
CLIENTS PROJECT:	22-9525
ENGINEERS PROJECT:	4321-095
CAD REFERENCE:	4321-095-E01

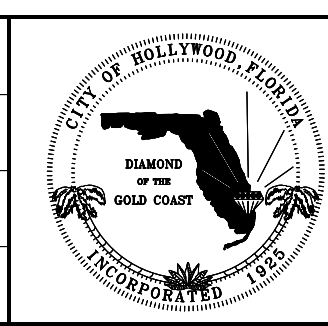

CITY OF HOLLYWOOD

SOUTHERN REGIONAL WASTEWATER TREATMENT PLANT	
CLARIFIER No. 3 REPAIR	
ELECTRICAL GENERAL NOTES	

DATE:	JANUARY 2023
SHEET:	10 OF 17
DRAWING:	E-1

BID SET

ABBR.	DESCRIPTION
A	AMMETER, AMPERE
AB	ALARM BELL
AC	ALTERNATING CURRENT
AF	CB AMPERE FRAME SIZE
AFD	ADJUSTABLE FREQUENCY DRIVE
AFF	ABOVE FINISHED FLOOR
AFG	ABOVE FINISHED GRADE
AHJ	AUTHORITY HAVING JURISDICTION
AIC	SYMM. AMPS INTERRUPTING CAP.
AL	ALUMINIUM, ALARM LIGHT
AS	AMMETER SENSOR OR SWITCH
ASB	ALARM SILENCE BUTTON
ASYM	ASYMMETRICAL
AT	CB AMPERE TRIP SETTING
ATS	AUTOMATIC TRANSFER SWITCH
AUX	AUXILIARY
AWG	AMERICAN WIRE GAUGE
BC	BARE COPPER
BCG	BATTERY CHARGER
BSDG	BUILDING
C	CONDUIT, CONTACTOR
CB	CIRCUIT BREAKER
CCB	CONTROL CIRCUIT BREAKER
CDB	CONC ENCASED DUCT BANK
CKT	CIRCUIT
CMS	COMBINATION MOTOR STARTER
CNTL	CONTROL
C.O.	CONDUIT ONLY
CONC	CONCRETE
CPT	CONTROL POWER TRANSFORMER
CR	CONTROL RELAY
CT	CURRENT TRANSFORMER
DC	DIRECT CURRENT
DEF	DIESEL EXHAUST FLUID
DDPT	DOUBLE POLE DOUBLE THROW
EC	EMPTY CONDUIT
ECB	EMERGENCY CIRCUIT BREAKER
ECDB	EX CONC ENCASED DUCT BANK
ECP	EQUIPMENT CONTROL PANEL
EF	EXHAUST FAN
EG	EMERGENCY GENERATOR
EMH	ELECT MANHOLE (SEE MAS)
EIT	ELECTRICAL METAL TUBING
ENCL	ENCLOSURE
EPB	EXISTING PULLBOX
EQUIP	EQUIPMENT
ESB	EMERGENCY STOP BUTTON
ETM	ELAPSED TIME METER
EX	EXISTING
FB	FUSE BLOCK
FDR	FEEDER
F.FU	FUSE
FI	FLOW INDICATOR
FL	LAMP FLASHER
FLA	FULL LOAD AMPS
FLEX	FLEXIBLE CONDUIT
FLR	FLOOR
FLUOR	FLUORESCENT
FM	FLOW METER
FMC	FLEXIBLE METAL CONDUIT
F.O.	FAIL OPEN
FOC	FIBER OPTIC CABLE
FS	FLOW SWITCH
FT	FLOW TRANSMITTER
FUT	FUTURE
FVNR	FULL VOLTAGE NON-REVERSING
G	GREEN, GROUND
GALV	GALVANIZED
GDR	GROUNDING RESISTOR
GEC	GROUNDING ELECTRODE CONDUCTOR
GEN	GENERATOR
GFCI	GROUND FAULT CIRCUIT INTERRUPTER
GFR	GROUND FAULT RELAY
GND	GROUND
GRS	GALVANIZED RIGID STEEL (CONDUIT)
GTB	GENERATOR TIE BREAKER
H	HANDHOLE
HID	HIGH INTENSITY DISCHARGE
HOA	HAND/OFF/AUTO
HOR	HAND/OFF/REMOTE
HP	HORSEPOWER
HPS	HIGH PRESSURE SODIUM
HTR	HEATER
HV	HIGH VOLTAGE
HVAC	HEAT, VENTILATION, AIR COND.
HZ	HERTZ (FREQUENCY)
IC	INTERRUPTING CAPACITY
ID	INSIDE DIAMETER
IMC	INTERMEDIATE METAL CONDUIT
INST	INSTANTANEOUS
I/O	INPUT / OUTPUT SIGNALS
IP	INSTRUMENT PANEL
ISR	INTRINSIC SAFE RELAY
JB	JUNCTION BOX
K	KEY OR KIRK KEY INTERLOCK
kcmil	1000 CIRCULAR MILS
kV	KILOVOLTS
kVA	KILOVOLT-AMPERE
kVAR	KILOVOLT-AMPERE REACTIVE
kW	KILOWATT
kWh	KILOWATT-HOUR
LA	LIGHTING ARRESTER
LC	LOAD CENTER
LCP	LOCAL CONTROL PANEL
LFMC	LIQUID TIGHT FLEX METAL CONDUIT
LP-#	LIGHTING PANEL NUMBER #
LR	LOCAL/REMOTE OR LATCHING RELAY
LRA	LOCKED ROTOR AMPS
LS	LIMIT SWITCH
LT	LEVEL TRANSDUCER
LTC	LIGHTING CONTACTOR
LTG	LIGHTING
LV	LOW VOLTAGE
M	MOTOR OR MOTOR CONTACTOR
MAS	MAINTENANCE ACCESS STRUCTURE
MA	MILLIAMPS
MAX	MAXIMUM
MBS	MANUAL BYPASS SWITCH
MC	METAL CLAD
MCA	MAXIMUM CIRCUIT AMPS
MCB	MAIN CIRCUIT BREAKER
MCC	MOTOR CONTROL CENTER
MDP	MAIN DISTRIBUTION PANEL
MERC	MERCURY VAPOR
MFG	MANUFACTURER
MFR	MULTI-FUNCTIONAL RELAY
MGB	MAIN GROUNDING BUS
MLO	MAIN LUGS ONLY
MOC	MAXIMUM OVERCURRENT PROTECTION
MOV	MOTOR OPERATED VALVE
MPZ	MINI-POWER ZONE
MS	MOTOR STARTER
MSC	MFR SUPPLIED CABLE
MTS	MANUAL TRANSFER SWITCH
MT	MOUNT
MTD	MOTOR TEMPERATURE DETECTOR
MV	MEDIUM VOLTAGE
N	NEUTRAL
NA	NOT APPLICABLE
NC	NORMALLY CLOSED
NEMA	NATIONAL ELEC. MFR. ASSOC.
NF	NON-FUSED
NIC	NOT IN CONTRACT
NO	NORMALLY OPEN
NP	NAMEPLATE
NTS	NOT TO SCALE
OC	OCCUPANCY CONTROL
OD	OUTSIDE DIAMETER
GND	GROUND
OH	OVERHEAD
OVS	OPERATOR WORK STATION
P	POLE
PB	PULL BOX OR PUSH BUTTON
PC	PHOTOCELL
PCP	PROCESS CONTROL PANEL
PF	POWER FACTOR
PH	PHASE
PL	PILOT LIGHT
PLC	PROGRAMMABLE LOGIC CONTROLLER
PM	POWER MONITOR UNIT
PMU	POWER MONITOR UNIT
PNL	PANEL
PP	POWER PANEL (480VAC)
PR	PAIR
PS	PRESSURE SWITCH
PT	POTENTIAL TRANSFORMER
PVC	POLYVINYL CHLORIDE CONDUIT
PWR	POWER
RCPT	RECEPTACLE
REF	REFERENCE
REQD	REQUIRED
RGS	RIGID GALVANIZED STEEL CONDUIT
RM	ROOM
RMC	RIGID METAL CONDUIT
RMS	ROOT MEAN SQUARE
RS	RIGID STEEL
RTD	RESISTANCE TEMPERATURE DETECTOR
RTU	REMOTE TELEMETRY UNIT
SA	SURGE ARRESTER
SC	SURGE CAPACITOR
SEC	SECONDARY
SEL	SELECTOR
SF	SUPPLY FAN
SH	SPACE HEATER
SLD	SINGLE LINE DIAGRAM
SMH	SIGNAL MAINTENANCE HOLE
S/N	SOLID NEUTRAL
SPEC	SPECIFICATIONS
SPD	SURGE PROTECTIVE DEVICE
SSRVS	SOLID STATE REDUCED VOLTAGE ST.
SST	STAINLESS STEEL
ST	ALARM STROBE LIGHT
SUB	SUBSTATION
SV	SOLENOID VALVE
SW	SWITCH
SWBD	SWITCHBOARD
SWGR	SWITCHGEAR
SYM	SYMMETRICAL
SYS	SYSTEM
T	THERMOSTAT
TB	TERMINAL BLOCK
TDR	TIME DELAY RELAY
TEL	TELEPHONE
TEMP	TEMPERATURE
TJB	TERMINAL JUNCTION BOX
TS	THERMAL SWITCH
TSP	TWISTED SHIELDED PAIR
TVSS	TRANSIENT VOLTAGE SURGE SUPPR.
TYP	TYPICAL
UGE	UNDERGROUND ELECTRIC UTILITY
U/G	UNDERGROUND
UPS	UNINTERRUPTIBLE POWER SUPPLY
UVR	UNDERVOLTAGE RELAY
V	VOLT OR VOLTMETER
VA	VOLTAMPERE
VAR	VOLTAMPERE REACTIVE
VFD	VARIABLE FREQUENCY DRIVE
VS	VOLTMETER SWITCH
W	WATT
WHD	WATTHOUR DEMAND METER
WP	WEATHER PROOF
WW	WIREWAY
XFMR	TRANSFORMER
XMTR	TRANSMITTER
XP	EXPLOSION PROOF
Z	IMPEDANCE

ABBR.	DESCRIPTION
HH	HANDHOLE
HID	HIGH INTENSITY DISCHARGE
HOA	HAND/OFF/AUTO
HOR	HAND/OFF/REMOTE
HP	HORSEPOWER
HPS	HIGH PRESSURE SODIUM
HTR	HEATER
HV	HIGH VOLTAGE
HVAC	HEAT, VENTILATION, AIR COND.
HZ	HERTZ (FREQUENCY)
IC	INTERRUPTING CAPACITY
ID	INSIDE DIAMETER
IMC	INTERMEDIATE METAL CONDUIT
INST	INSTANTANEOUS
I/O	INPUT / OUTPUT SIGNALS
IP	INSTRUMENT PANEL
ISR	INTRINSIC SAFE RELAY
JB	JUNCTION BOX
K	KEY OR KIRK KEY INTERLOCK
kcmil	1000 CIRCULAR MILS
kV	KILOVOLTS
kVA	KILOVOLT-AMPERE
kVAR	KILOVOLT-AMPERE REACTIVE
kW	KILOWATT
kWh	KILOWATT-HOUR
LA	LIGHTING ARRESTER
LC	LOAD CENTER
LCP	LOCAL CONTROL PANEL
LFMC	LIQUID TIGHT FLEX METAL CONDUIT
LP-#	LIGHTING PANEL NUMBER #
LR	LOCAL/REMOTE OR LATCHING RELAY
LRA	LOCKED ROTOR AMPS
LS	LIMIT SWITCH
LT	LEVEL TRANSDUCER
LTC	LIGHTING CONTACTOR
LTG	LIGHTING
LV	LOW VOLTAGE
M	MOTOR OR MOTOR CONTACTOR
MAS	MAINTENANCE ACCESS STRUCTURE
MA	MILLIAMPS
MAX	MAXIMUM
MBS	MANUAL BYPASS SWITCH
MC	METAL CLAD
MCA	MAXIMUM CIRCUIT AMPS
MCB	MAIN CIRCUIT BREAKER
MCC	MOTOR CONTROL CENTER
MDP	MAIN DISTRIBUTION PANEL
MERC	MERCURY VAPOR
MFG	MANUFACTURER
MFR	MULTI-FUNCTIONAL RELAY
MGB	MAIN GROUNDING BUS
MLO	MAIN LUGS ONLY
MOC	MAXIMUM OVERCURRENT PROTECTION
MOV	MOTOR OPERATED VALVE
MPZ	MINI-POWER ZONE
MS	MOTOR STARTER
MSC	MFR SUPPLIED CABLE
MTS	MANUAL TRANSFER SWITCH
MT	MOUNT
MTD	MOTOR TEMPERATURE DETECTOR
MV	MEDIUM VOLTAGE
N	NEUTRAL
NA	NOT APPLICABLE
NC	NORMALLY CLOSED
NEMA	NATIONAL ELEC. MFR. ASSOC.
NF	NON-FUSED
NIC	NOT IN CONTRACT
NO	NORMALLY OPEN
NP	NAMEPLATE
NTS	NOT TO SCALE
OC	OCCUPANCY CONTROL
OD	OUTSIDE DIAMETER
GND	GROUND
OH	OVERHEAD
OVS	OPERATOR WORK STATION
P	POLE
PB	PULL BOX OR PUSH BUTTON
PC	PHOTOCELL
PCP	PROCESS CONTROL PANEL
PF	POWER FACTOR
PH	PHASE
PL	PILOT LIGHT
PLC	PROGRAMMABLE LOGIC CONTROLLER
PM	POWER MONITOR UNIT
PMU	POWER MONITOR UNIT
PNL	PANEL
PP	POWER PANEL (480VAC)
PR	PAIR
PS	PRESSURE SWITCH
PT	POTENTIAL TRANSFORMER
PVC	POLYVINYL CHLORIDE CONDUIT
PWR	POWER
RCPT	RECEPTACLE
REF	REFERENCE
REQD	REQUIRED
RGS	RIGID GALVANIZED STEEL CONDUIT
RM	ROOM
RMC	RIGID METAL CONDUIT
RMS	ROOT MEAN SQUARE
RS	RIGID STEEL
RTD	RESISTANCE TEMPERATURE DETECTOR
RTU	REMOTE TELEMETRY UNIT
SA	SURGE ARRESTER
SC	SURGE CAPACITOR
SEC	SECONDARY
SEL	SELECTOR
SF	SUPPLY FAN
SH	SPACE HEATER
SLD	SINGLE LINE DIAGRAM
SMH	SIGNAL MAINTENANCE HOLE
S/N	SOLID NEUTRAL
SPEC	SPECIFICATIONS
SPD	SURGE PROTECTIVE DEVICE
SSRVS	SOLID STATE REDUCED VOLTAGE ST.
SST	STAINLESS STEEL
ST	ALARM STROBE LIGHT
SUB	SUBSTATION
SV	SOLENOID VALVE
SW	SWITCH
SWBD	SWITCHBOARD
SWGR	SWITCHGEAR
SYM	SYMMETRICAL
SYS	SYSTEM
T	THERMOSTAT
TB	TERMINAL BLOCK
TDR	TIME DELAY RELAY
TEL	TELEPHONE
TEMP	TEMPERATURE
TJB	TERMINAL JUNCTION BOX
TS	THERMAL SWITCH
TSP	TWISTED SHIELDED PAIR
TVSS	TRANSIENT VOLTAGE SURGE SUPPR.
TYP	TYPICAL
UGE	UNDERGROUND ELECTRIC UTILITY
U/G	UNDERGROUND
UPS	UNINTERRUPTIBLE POWER SUPPLY
UVR	UNDERVOLTAGE RELAY
V	VOLT OR VOLTMETER
VA	VOLTAMPERE
VAR	VOLTAMPERE REACTIVE
VFD	VARIABLE FREQUENCY DRIVE
VS	VOLTMETER SWITCH
W	WATT
WHD	WATTHOUR DEMAND METER
WP	WEATHER PROOF
WW	WIREWAY
XFMR	TRANSFORMER
XMTR	TRANSMITTER
XP	EXPLOSION PROOF
Z	IMPEDANCE

ABBR.	DESCRIPTION
P	POLE
PB	PULL BOX OR PUSH BUTTON
PC	PHOTOCELL
PCP	PROCESS CONTROL PANEL
PF	POWER FACTOR
PH	PHASE
PL	PILOT LIGHT
PLC	PROGRAMMABLE LOGIC CONTROLLER
PM	POWER MONITOR UNIT
PMU	POWER MONITOR UNIT
PNL	PANEL
PP	POWER PANEL (480VAC)
PR	PAIR
PS	PRESSURE SWITCH
PT	POTENTIAL TRANSFORMER
PVC	POLYVINYL CHLORIDE CONDUIT
PWR	POWER
RCPT	RECEPTACLE
REF	REFERENCE
REQD	REQUIRED
RGS	RIGID GALVANIZED STEEL CONDUIT
RM	ROOM
RMC	RIGID METAL CONDUIT
RMS	ROOT MEAN SQUARE
RS	RIGID STEEL
RTD	RESISTANCE TEMPERATURE DETECTOR
RTU	REMOTE TELEMETRY UNIT
SA	SURGE ARRESTER
SC	SURGE CAPACITOR
SEC	SECONDARY
SEL	SELECTOR
SF	SUPPLY FAN
SH	SPACE HEATER
SLD	SINGLE LINE DIAGRAM
SMH	SIGNAL MAINTENANCE HOLE
S/N	SOLID NEUTRAL
SPEC	SPECIFICATIONS
SPD	SURGE PROTECTIVE DEVICE
SSRVS	SOLID STATE REDUCED VOLTAGE ST.
SST	STAINLESS STEEL
ST	ALARM STROBE LIGHT
SUB	SUBSTATION
SV	SOLENOID VALVE
SW	SWITCH
SWBD	SWITCHBOARD
SWGR	SWITCHGEAR
SYM	SYMMETRICAL
SYS	SYSTEM
T	THERMOSTAT
TB	TERMINAL BLOCK
TDR	TIME DELAY RELAY
TEL	TELEPHONE
TEMP	TEMPERATURE
TJB	TERMINAL JUNCTION BOX
TS	THERMAL SWITCH
TSP	TWISTED SHIELDED PAIR
TVSS	TRANSIENT VOLTAGE SURGE SUPPR.
TYP	TYPICAL
UGE	UNDERGROUND ELECTRIC UTILITY
U/G	UNDERGROUND
UPS	UNINTERRUPTIBLE POWER SUPPLY
UVR	UNDERVOLTAGE RELAY
V	VOLT OR VOLTMETER
VA	VOLTAMPERE
VAR	VOLTAMPERE REACTIVE
VFD	VARIABLE FREQUENCY DRIVE
VS	VOLTMETER SWITCH
W	WATT
WHD	WATTHOUR DEMAND METER
WP	WEATHER PROOF
WW	WIREWAY
XFMR	TRANSFORMER
XMTR	TRANSMITTER
XP	EXPLOSION PROOF
Z	IMPEDANCE

SYMBOL	DESCRIPTION
	TERMINAL JUNCTION BOX
	ELECTRICAL EQUIPMENT
	CEILING MOUNTED DOWNLIGHT LUMINAIRE - SEE SCHEDULE FOR TYPE
	FLUORESCENT LUMINAIRE, SURFACE OR LAY IN TYPE SEE SCHEDULE FOR TYPE
	LUMINAIRE AND POLE - SEE SCHEDULE FOR TYPE
	WALL MOUNTED LUMINAIRE - SEE SCHEDULE FOR TYPE
	GROUND ROD - 5/8" x 20' COPPER CLAD UNLESS OTHERWISE NOTED
	GROUND ROD IN TEST WELL - 5/8" x 20' COPPER CLAD UNLESS OTHERWISE NOTED
	EXIT LIGHTS - SOLID SECTION IS DIRECTION OF FACE SEE SCHEDULE FOR TYPE
	EMERGENCY LIGHT WITH BATTERY PACK SEE SCHEDULE FOR TYPE
	LIGHTING FIXTURE POWER AND SWITCHING LEGEND X = FIXTURE TYPE # = CIRCUIT NUMBER
	EXIT LIGHT WITH EMERGENCY LIGHTS SEE SCHEDULE FOR TYPE
	CONDUIT/CONDUCTOR - REFER TO CIRCUIT SCHEDULE
	HOME RUN - PANEL AND CIRCUIT NUMBER SHOWN
	EXPOSED CONDUIT AND CONDUCTORS*
	UNDERGROUND CONDUIT AND CONDUCTORS*
	YARD CONDUIT, REFER TO YARD CONDUIT SCHEDULE
	DIRECT BURIED CONDUIT
	CONCRETE ENCASED DUCT BANK
	CONDUIT, STUBBED AND CAPPED AS SHOWN
	GROUND WIRE, 4/0 CU UNLESS OTHERWISE NOTED
	WALL SWITCH: 2- DOUBLE POLE P- PILOT LIGHT # - CIRCUIT NO. 3- THREE WAY K- KEY OPERATED 4- FOUR WAY D- DIMMER WP- WEATHERPROOF CRE- CORROSION RESISTANT
	20A DUPLEX RECEPTACLE UNLESS SPECIFIED OTHERWISE WP - WEATHERPROOF C - CLOCK HANGER TL - TWIST LOCK CRE - CORROSION RESISTANT GFCI - GROUND FAULT INTERRUPTER FTC - FULL TIME COVER
	20A QUADRUPLE RECEPTACLE - UNLESS SPECIFIED OTHERWISE
	20A DUPLEX RECEPTACLE - UNLESS SPECIFIED OTHERWISE, MOUNTED FLUSH IN FLOOR.
	RECEPTACLE, SPECIAL PURPOSE - AMPERAGE AS INDICATED.
	TELEPHONE/DATA RECEPTACLE (OUTLET BOX, 18" AFF) W - WALL MOUNTED, 54" AFF
	TELEPHONE/DATA RECEPTACLE MOUNTED FLUSH IN FLOOR
	JUNCTION BOX NEMA 12 ENCLOSURE UNLESS INDICATED OTHERWISE, 4X = NEMA 4X SS
	FIRE ALARM PULL STATION
	ALARM HORN/STROBE LIGHT
	FIRE ALARM STROBE LIGHT
	ELEVATOR WARNING LIGHT
	FIRE ALARM SMOKE OR HEAT DETECTOR
	DUCT SMOKE DETECTOR
	FIRE ALARM CONTROL PANEL
	FIRE ALARM ANNUNCIATOR PANEL
	CONDUIT CHASE
	WATER HEATER

SYMBOL	DESCRIPTION
	ELECTRICAL INTERLOCK
	DRAWOUT CIRCUIT BREAKER, LOW VOLTAGE 600= FRAME RATING, 400=TRIP SETTING
	DRAWOUT CIRCUIT BREAKER, MEDIUM VOLTAGE 600= FRAME RATING, 400=TRIP SETTING
	DRAWOUT FUSED SWITCH, LOW OR MEDIUM VOLTAGE 600= FRAME RATING, 400=FUSE RATING
	CURRENT TRANSFORMER, NUMBER OF WINDINGS INDICATED
	TRANSFORMER, VOLTAGES, PHASE AND RATING INDICATED AS APPLICABLE
	LIGHTNING ARRESTER
	CAPACITOR OR SURGE CAPACITOR
	METER SCALE RANGE SHOWN IF REQUIRED PM - PHASE MONITOR A - AMPS P - POWER METER V - VOLTS
	FUSE
	TRANSIENT VOLTAGE SURGE SUPPRESSION
	GROUND
	CONTROL TRANSFORMER
	GROUND FAULT RELAY WITH C.T.
	PUSH-BUTTON SWITCH, MOMENTARY CONTACT, NORMALLY OPEN
	PUSH-BUTTON SWITCH, MOMENTARY CONTACT, NORMALLY CLOSED
	PUSH BUTTON SWITCH, MAINTAINED CONTACTS WITH MECHANICAL INTERLOCK
	REMOTE DEVICE
	INDICATING LIGHT - LETTER INDICATES COLOR A - AMBER G - GREEN B - BLUE R - RED C - CLEAR W - WHITE
	PUSH TO TEST AND CONNECT INDICATING LIGHT SCHEMATIC DIAGRAMS ONLY A - AMBER G - GREEN B - BLUE R - RED C - CLEAR W - WHITE
	MOTOR, SQUIRREL CAGE INDUCTION UNLESS OTHERWISE NOTED - HORSEPOWER INDICATED
	OVERLOAD RELAY HEATER
	MAGNETIC STARTER WITH NEMA SIZE INDICATED
	MOTOR CIRCUIT PROTECTOR, MAGNETIC, 3 POLE UNLESS INDICATED OTHERWISE.
	CIRCUIT BREAKER, THERMAL MAGNETIC TRIP SHOWN, 3 POLE UNLESS INDICATED OTHERWISE.
	FUSED SWITCH, SWITCH AND FUSE CURRENT RATING INDICATED, 3 POLE UNLESS INDICATED OTHERWISE.
	SWITCH - CURRENT RATING INDICATED, 3 POLE UNLESS INDICATED OTHERWISE.
	DISC SWITCH - FUSED, NON-FUSED
	GENERATOR



**NOTES:**

1. ALL EXPOSED CONDUITS ON CLARIFIER SHALL BE PVC COATED ALUMINUM METAL CONDUIT
2. JUNCTION BOXES SHALL BE 316 STAINLESS STEEL WITH HINGED COVERS
3. SUPPORTING STRUTS, STRAPS, HARDWARE SHALL BE 316 STAINLESS STEEL

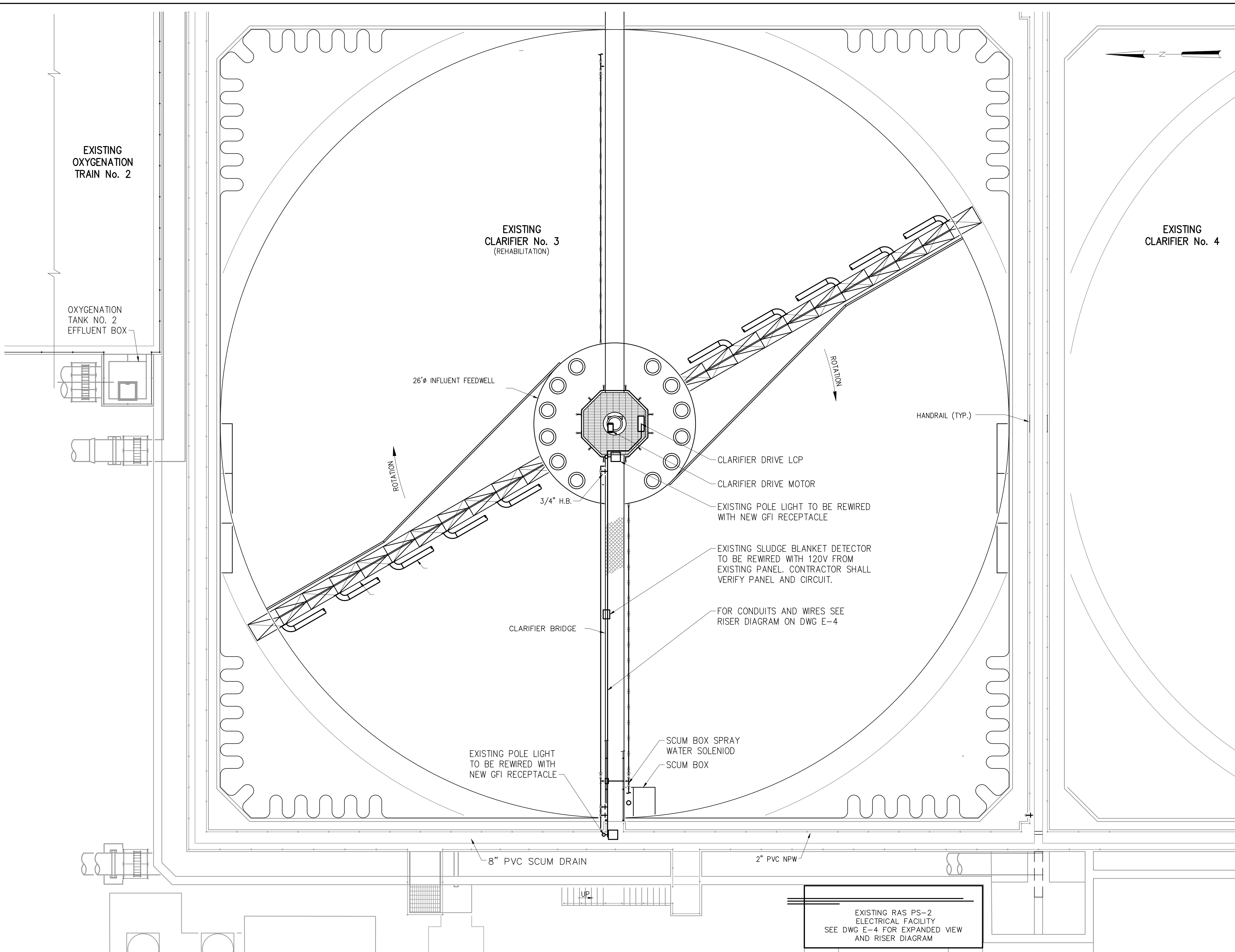

**LEGEND**

- EXISTING FACILITY
- EQUIPMENT TO BE REPLACED



EXISTING RAS PS-2  
ELECTRICAL FACILITY  
SEE DWG E-4 FOR EXPANDED VIEW  
AND RISER DIAGRAM

PLOT DATE: 1/5/2023 11:29 AM BY: TBODAS

NO.	DATE	ISSUED FOR	BY

DESIGNED	JMB
DRAWN	JMB
CHECKED	JCB
PROJ. ENGR.	TAV

JOHN C. BURKE  
No. 17301

P.E.

**Hazen**

HAZEN AND SAWYER  
4000 HOLLYWOOD BOULEVARD, SUITE 750N  
HOLLYWOOD, FLORIDA 33021

THE SCALE BAR SHOWN BELOW MEASURES ONE INCH LONG ON THE ORIGINAL DRAWING.

CONTRACT:	—
CLIENTS PROJECT:	22-9525
ENGINEERS PROJECT:	4321-095
CAD REFERENCE:	4321-095-E03

CITY OF HOLLYWOOD

SOUTHERN REGIONAL WASTEWATER TREATMENT PLANT

CLARIFIER No. 3 REPAIR

ALTERNATIVE BID ITEMS A-1 & A-2  
CLARIFIER NO.3 – ELECTRICAL PLAN

DATE:	JANUARY 2023
SHEET:	12 OF 17
DRAWING:	E-3

BID SET

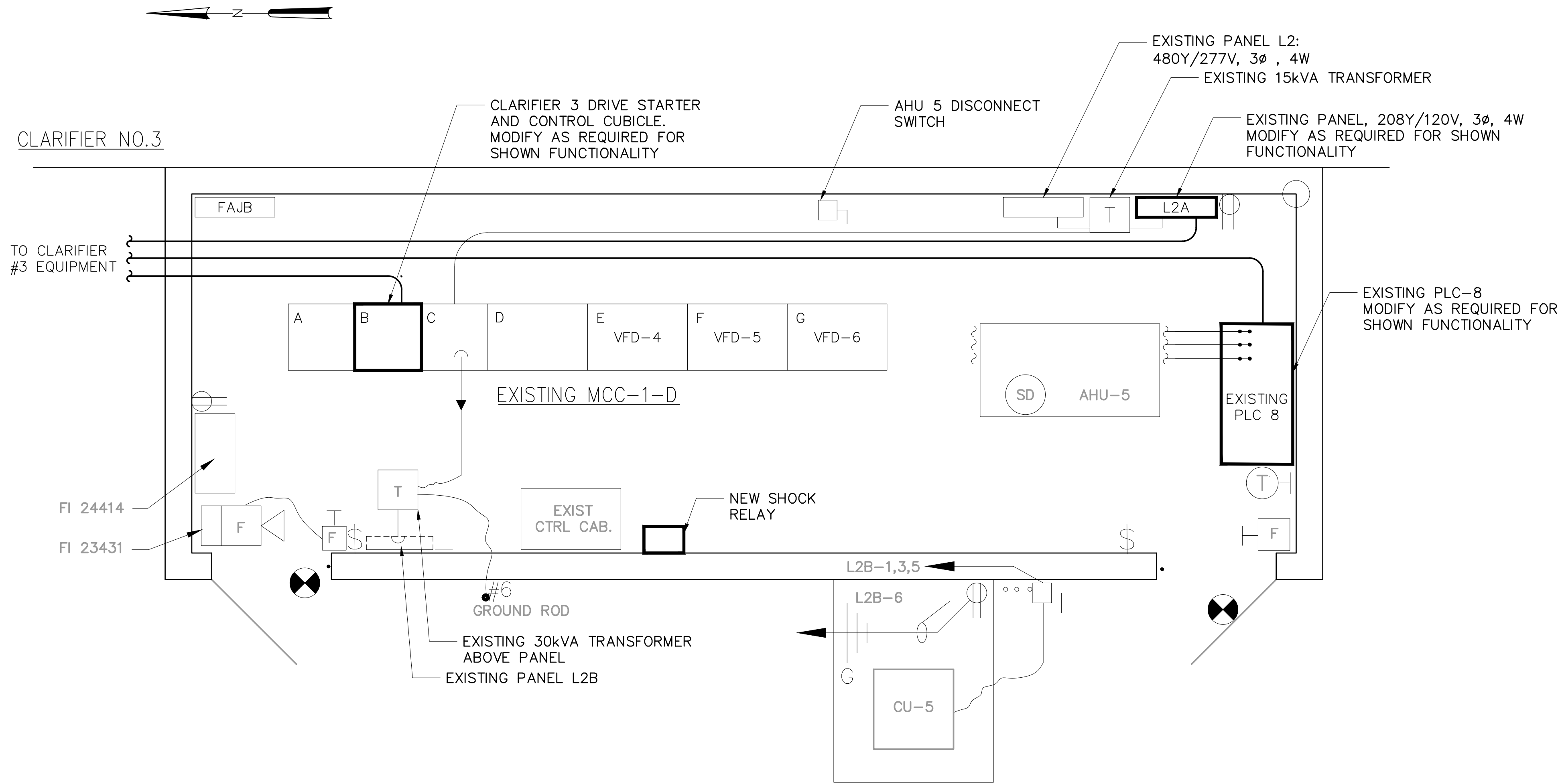

**RAS PUMP STATION #2  
ELECTRICAL ROOM PLAN VIEW**

PLAN VIEW BOLD ITEMS ARE EITHER NEW OR SHALL BE MODIFIED AS REQUIRED TO PROVIDE FUNCTIONALITY SHOWN ON DRAWINGS AND IN SPECIFICATIONS.

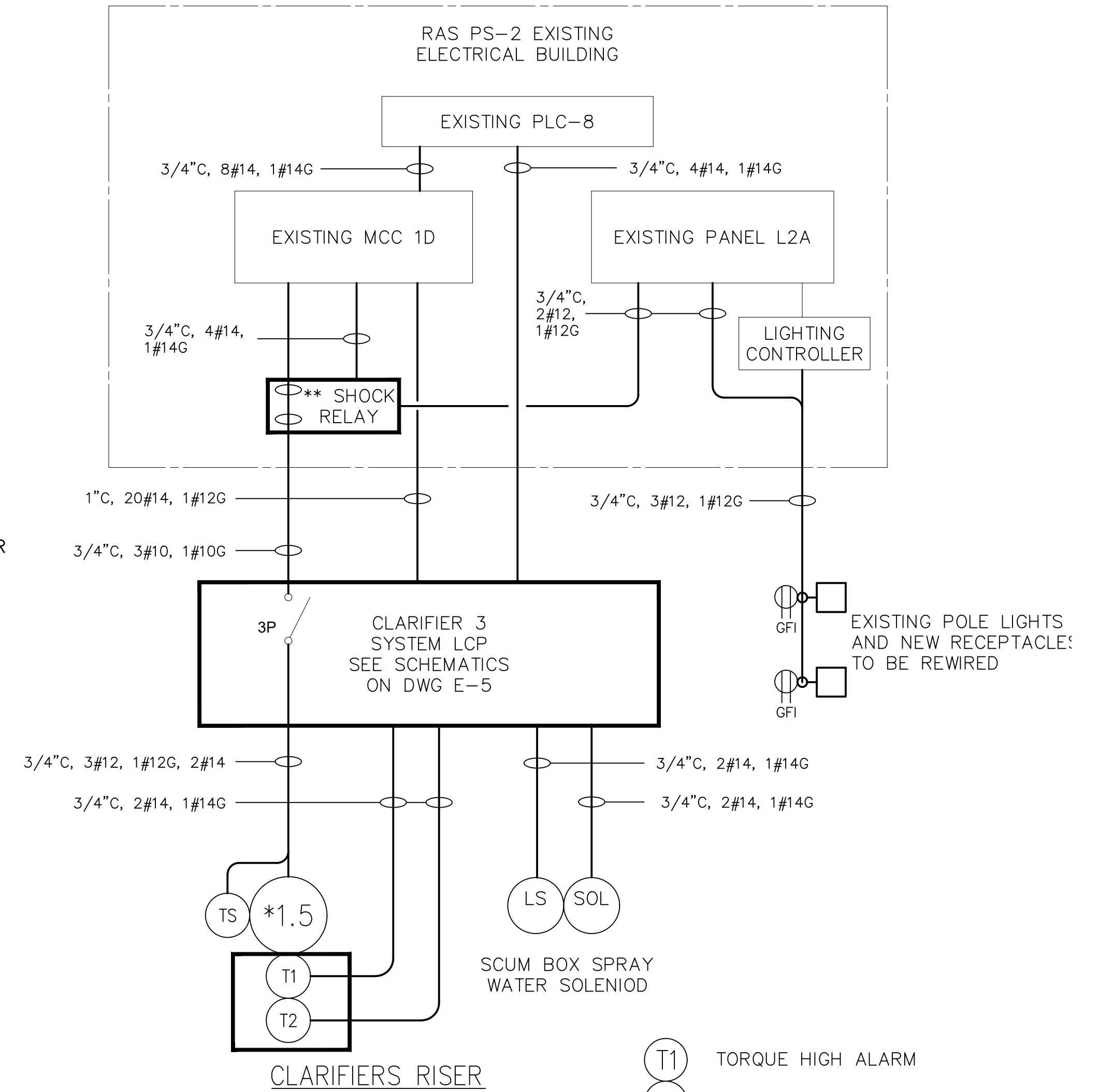

- (T1) TORQUE HIGH ALARM
- (T2) TORQUE HIGH SHUTDOWN
- (TS) MOTOR THERMOSTAT
- DS DISCONNECT SWITCH

**NOTES:**

1. \* CONTRACTOR SHALL VERIFY MOTOR HP
2. \*\* SHOCK RELAY AMP RANGE SHALL BE AS CLOSE AS POSSIBLE TO THE CLARIFIER DRIVE ACTUAL RUNNING AMPS. SEE ELECTRICAL SPECIFICATION 16950 FOR SHOCK RELAY DETAILS. SHOCK RELAY SHALL BE INSTALLED IN AN NEMA ONE ENCLOSURE WITH A HINGED COVER.
3. CONTRACTOR SHALL PROVIDE AND INSTALL NEW CONDUIT AND WIRING TO THE TWO (2) EXISTING LIGHT POLES.
4. CONTRACTOR SHALL PROVIDE AND INSTALL NEW CONDUIT, WIRING, DEVICE BOXES AND GFI RECEPTACLES FOR EXISTING RECEPTACLES.

PLOT DATE: 1/25/2023 11:29 AM BY: TBCKAS

DESIGNED	JMB		
DRAWN	JMB		
CHECKED	JCB		
PROJ. ENGR.	TAV		
NO.	DATE	ISSUED FOR	BY

JOHN C. BURKE  
No. 17301

P.E.



THE SCALE BAR SHOWN BELOW MEASURES ONE INCH LONG ON THE ORIGINAL DRAWING.

CONTRACT: -  
CLIENTS PROJECT: 22-9525  
ENGINEERS PROJECT: 4321-095  
CAD REFERENCE: 4321-095-E04

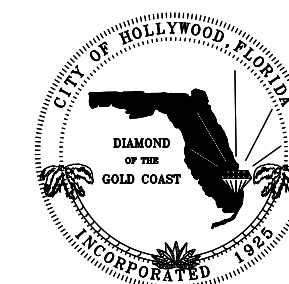

CITY OF HOLLYWOOD

SOUTHERN REGIONAL WASTEWATER TREATMENT PLANT  
CLARIFIER No. 3 REPAIR

ALTERNATIVE BID ITEMS A-1 & A-2  
RAS PS NO.2 - ELECTRICAL PLAN

DATE: JANUARY 2023  
SHEET: 13 OF 17  
DRAWING: E-4

BID SET

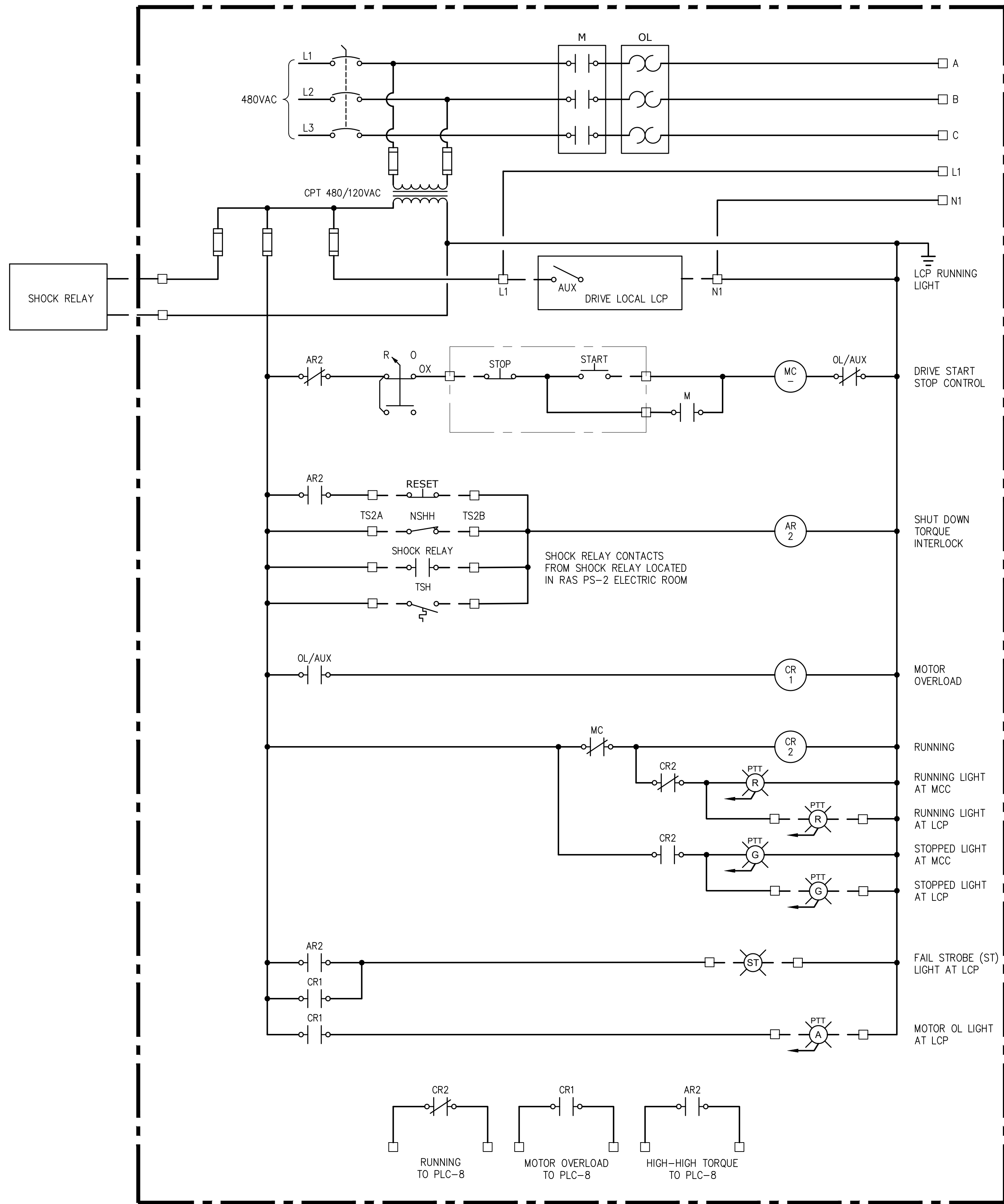

**CLARIFIER 3 DRIVE MOTOR STARTER – PROPOSED**

EXISTING MOTOR STARTER IS LOCATED AT MCC-1D IN RAS PS-2 ELECTRIC ROOM. MODIFY AS REQUIRED TO OBTAIN FUNCTIONALITY AS SHOWN ON THE DRAWINGS AND REQUIRED BY THE SPECIFICATIONS

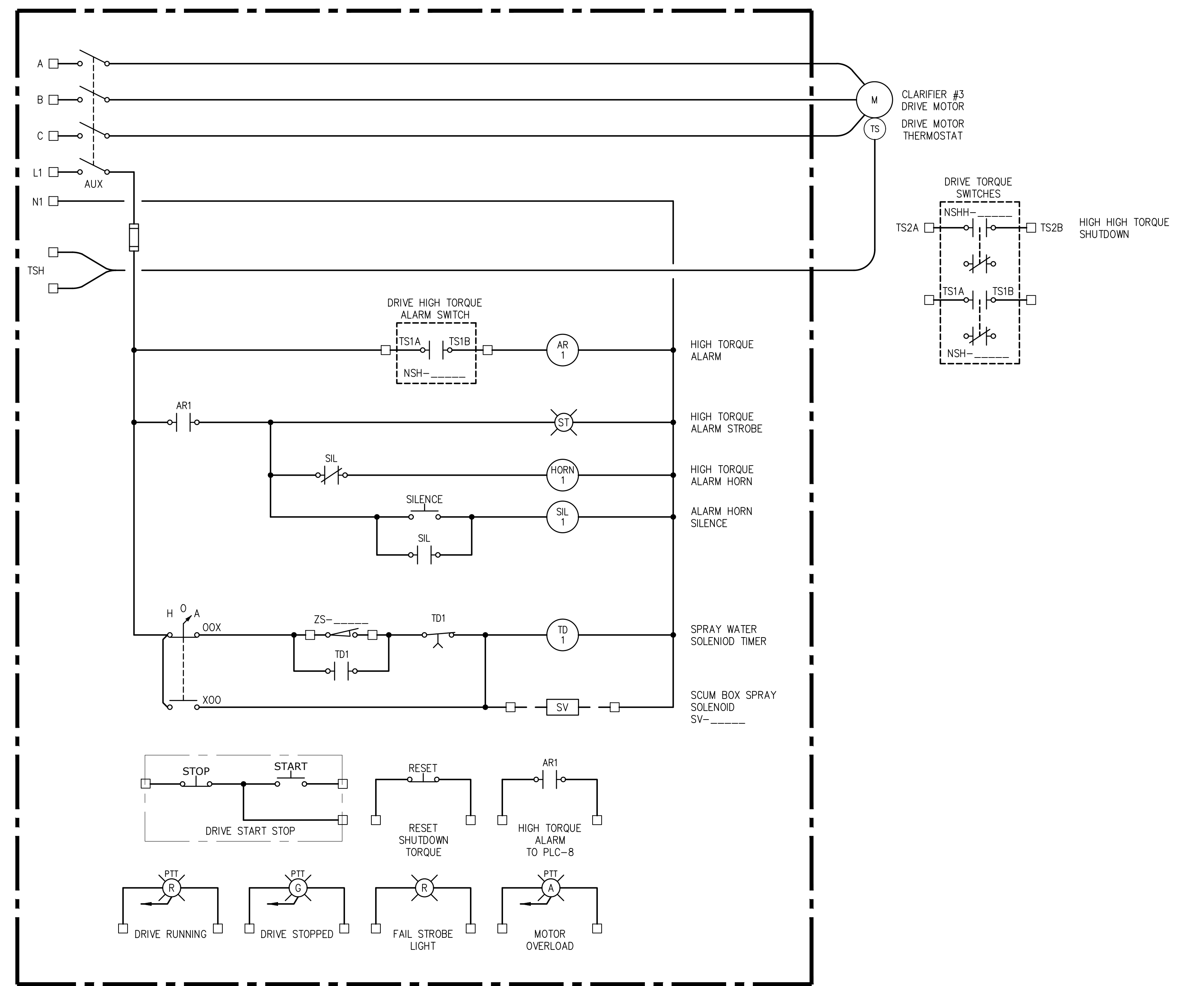
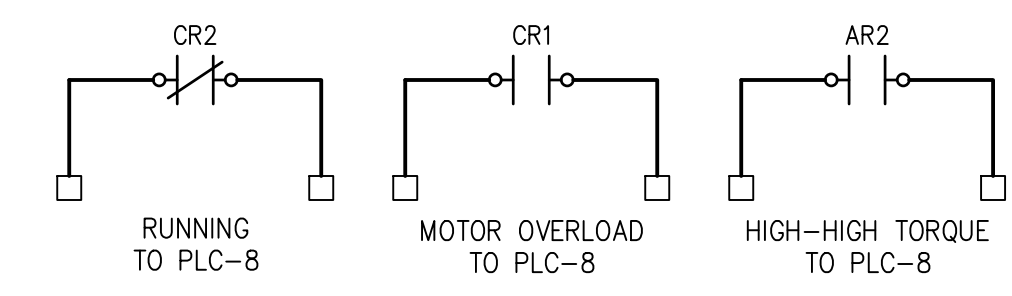

**CLARIFIER 3 LCP – PROPOSED**

AT CLARIFIER DRIVE

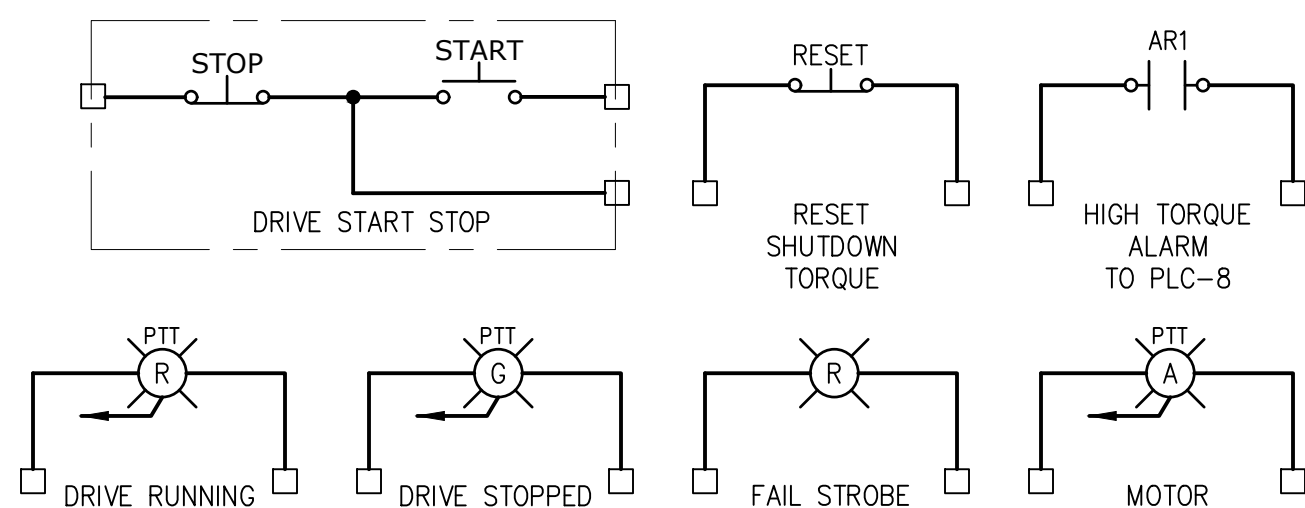

- NOTES:**
- MCC STARTER SCHEMATICS SHOWN ARE BASED ON RECORD DRAWINGS AND LIMITED FIELD OBSERVATIONS. ACTUAL WIRING MAY BE DIFFERENT. PROVIDE INDICATED FUNCTIONALITY.

**LEGEND:**  
 TERMINATION POINT FOR EXTERNAL SIGNALS

PLOT DATE: 1/5/2023 11:29 AM BY: IBCCAS

DESIGNED	JMB		
DRAWN	JMB		
CHECKED	JCB		
PROJ. ENGR.	TAV		
NO.	DATE	ISSUED FOR	BY

DESIGNED	JMB		
DRAWN	JMB		
CHECKED	JCB		
PROJ. ENGR.	TAV		
NO.	DATE	ISSUED FOR	BY

**Hazen**  
 HAZEN AND SAWYER  
 4000 HOLLYWOOD BOULEVARD, SUITE 750N  
 HOLLYWOOD, FLORIDA 33021

THE SCALE BAR SHOWN BELOW MEASURES ONE INCH LONG ON THE ORIGINAL DRAWING.

CONTRACT:	–
CLIENTS PROJECT:	22–9525
ENGINEERS PROJECT:	4321–095
CAD REFERENCE:	4321–095–E05

CITY OF HOLLYWOOD, FLORIDA  
 CITY OF HOLLYWOOD

SOUTHERN REGIONAL WASTEWATER TREATMENT PLANT
CLARIFIER No. 3 REPAIR
ALTERNATIVE BID ITEMS A-1 & A-2
SINGLE LINE DRAWING

DATE:	JANUARY 2023
SHEET:	14 OF 17
DRAWING:	E-5

BID SET



HMI (SCADA)

HMI(SCADA)

PLC-8

PLC-8

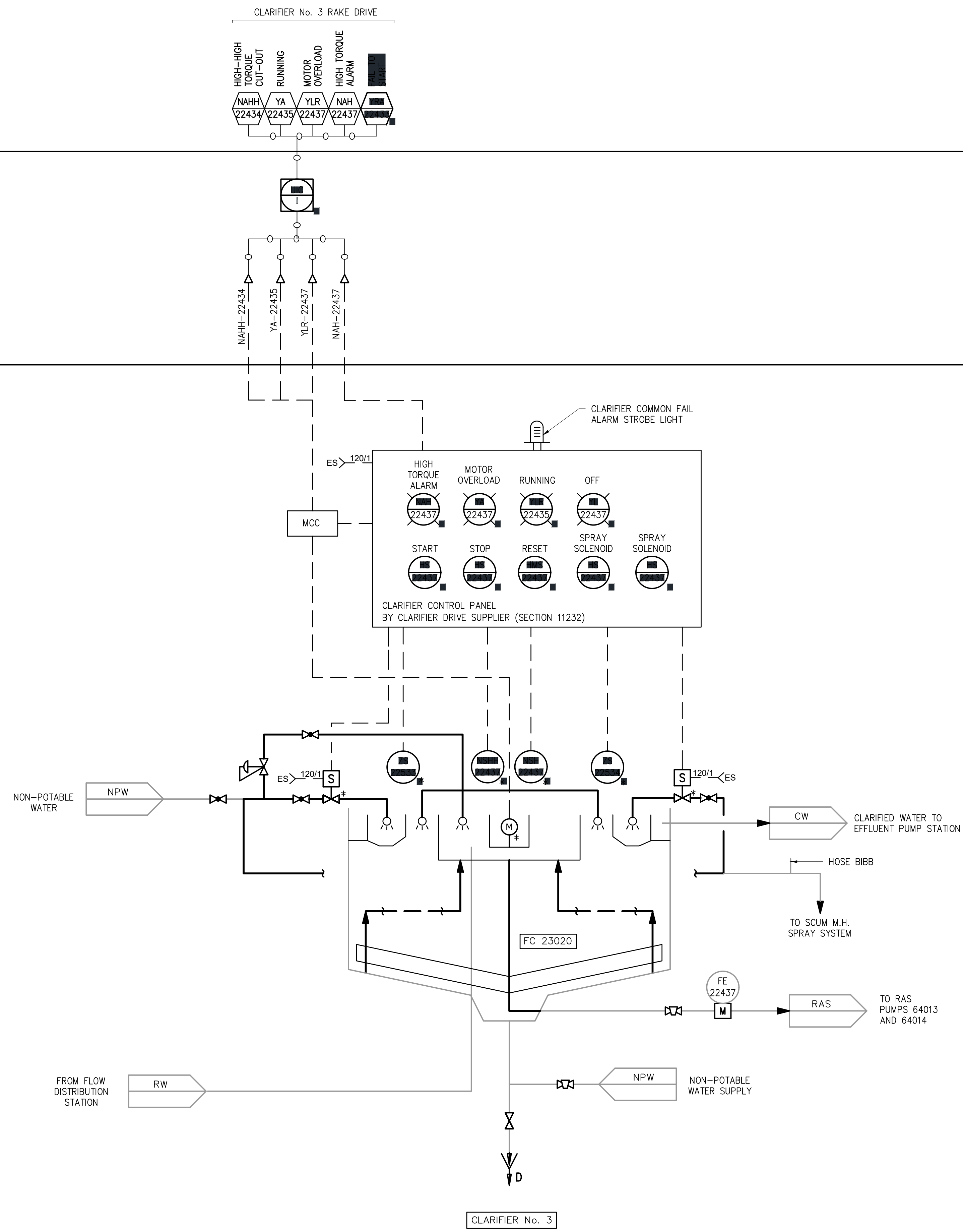

- NOTES:
- EXISTING SPARE DISCRETE INPUT TERMINALS IN CONTROL PANEL "PLC-8" SHALL BE USED FOR THE NEW STATUS SIGNALS SHOWN AND LISTED IN SECTION 17920. EXISTING PLC LOGIC PROGRAM SHALL BE MODIFIED TO INCORPORATE THESE SIGNALS INTO THE EXISTING SCADA SYSTEM. SEE SECTION 17300 FOR ADDITIONAL INFORMATION.
  - SCADA HMI SCREENS AND SCADA ALARM SERVER/HISTORIAN ARE TO BE MODIFIED TO INCORPORATE THE SIGNALS SHOWN AND LISTED IN SECTION 17920. SEE SECTION 17300 FOR ADDITIONAL INFORMATION.
  - REFER TO ELECTRICAL DRAWINGS FOR HAZARDOUS AREA CLASSIFICATIONS. ALL EQUIPMENT INSTALLED IN CLASSIFIED AREAS SHALL BE SUITABLE FOR THE ENVIRONMENT.
  - PLC-8 LOGIC PROGRAM SHALL BE REPLACED WITH NEW PLC LOGIC PROGRAM. SEE SECTION 17300 FOR MORE INFORMATION. CONTRACTOR TO PERFORM START-UP OF CLARIFIER NO. 3 UPON COMPLETION OF WORK.

EQUIPMENT MARKED WITH AN ASTERISK (\*) FURNISHED BY CLARIFIER MECHANISM SUPPLIER (SECTION 11232).

PLOT DATE: 1/5/2023 11:29 AM BY: TBOCAS

DESIGNED	KCR		
DRAWN	KCR		
CHECKED	JPC		
PROJ. ENGR.	TAV		
NO.	DATE	ISSUED FOR	BY

DESIGNED KCR  
 DRAWN KCR  
 CHECKED JPC  
 PROJ. ENGR. TAV

\_\_\_\_\_  
 KEITH R. DINNEN P.E.  
 No. 78757

**Hazen**  
 HAZEN AND SAWYER  
 4000 HOLLYWOOD BOULEVARD, SUITE 750N  
 HOLLYWOOD, FLORIDA 33021

THE SCALE BAR SHOWN BELOW MEASURES ONE INCH LONG ON THE ORIGINAL DRAWING.

CONTRACT: -  
 CLIENTS PROJECT: 22-9525  
 ENGINEERS PROJECT: 4321-095  
 CAD REFERENCE: 4321-073102

CITY OF HOLLYWOOD, FLORIDA  
 CITY OF HOLLYWOOD

SOUTHERN REGIONAL WASTEWATER TREATMENT PLANT  
 CLARIFIER No. 3 REPAIR  
 ALTERNATIVE BID ITEMS A-1 AND A-2  
 CLARIFIER NO.3 P&ID

DATE: JANUARY 2023  
 SHEET: 16 OF 17  
 DRAWING: 1-2

BID SET

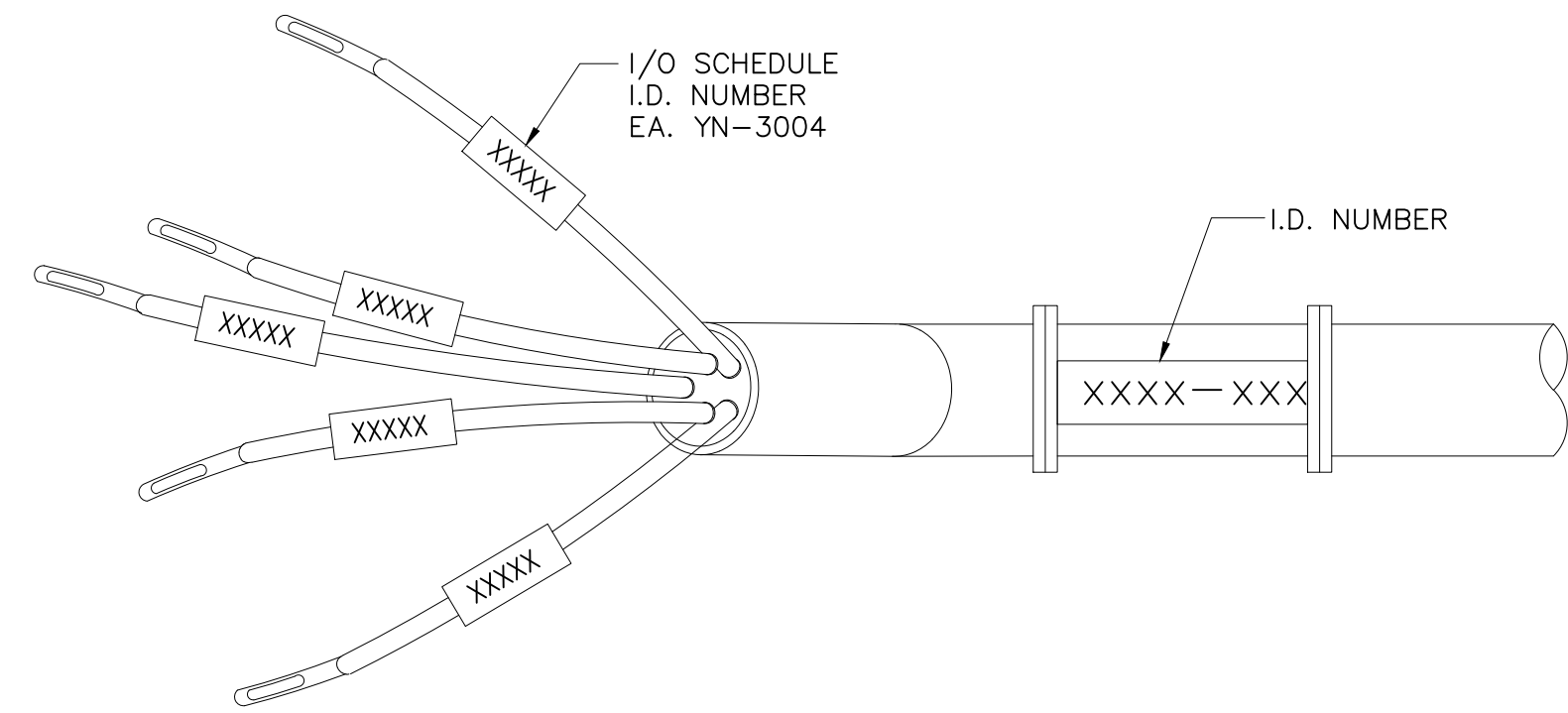

INSTRUMENT CONTROL CABLE

DETAIL	STD
N.T.S.	-

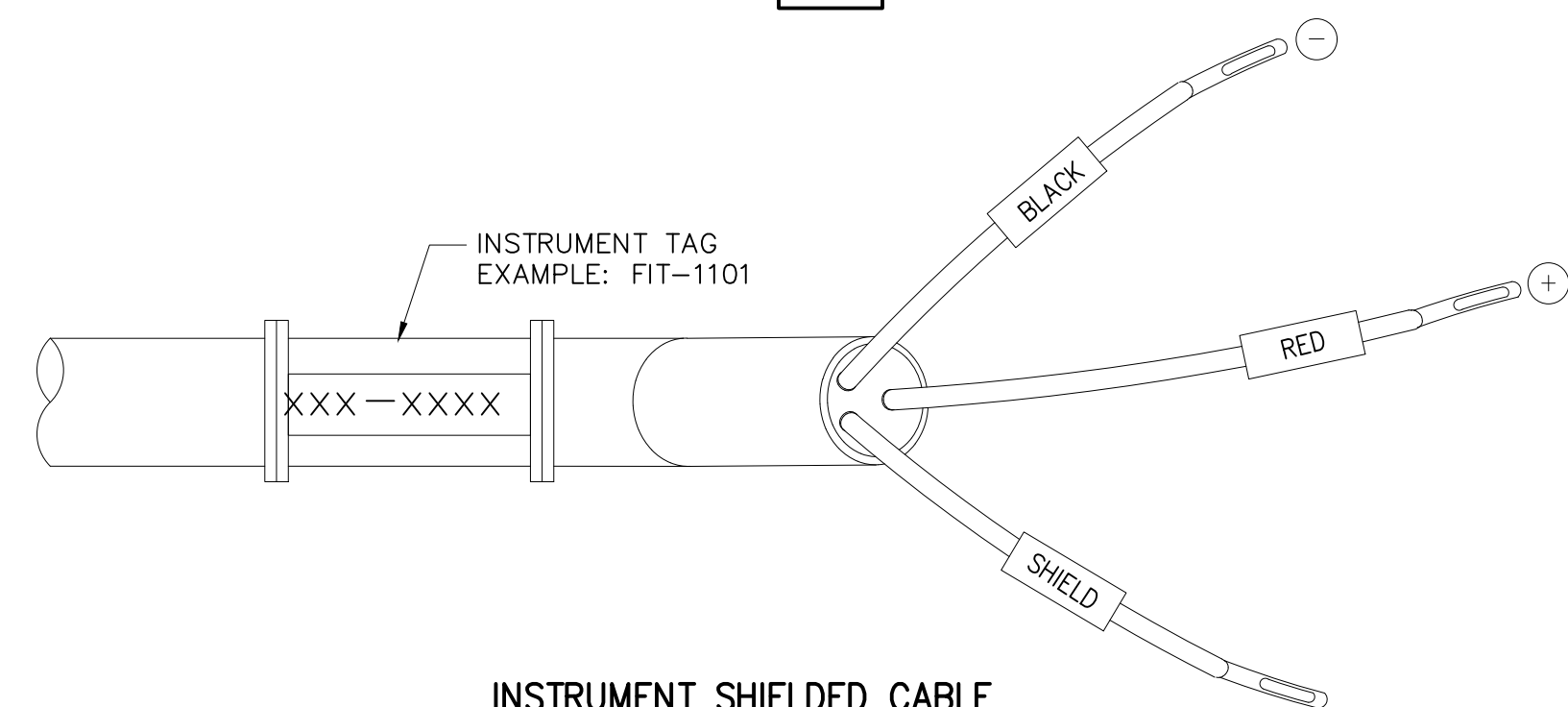

INSTRUMENT SHIELDED CABLE

DETAIL	STD
N.T.S.	-

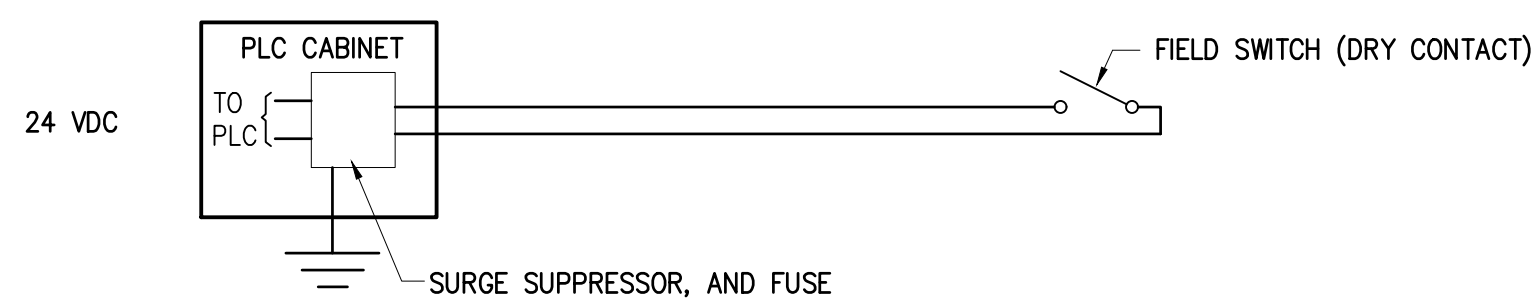

DISCRETE PLC/INPUT CIRCUIT

DETAIL	STD
N.T.S.	-

DATE: 7/5/2023 11:28 AM BY: TBGAS  
 XREF: ..\Block\4321-0951B

NO.	DATE	ISSUED FOR	BY

DESIGNED	KCR
DRAWN	KCR
CHECKED	JPC
PROJ. ENGR.	TAV

KEITH R. DINNEN P.E.  
 No. 78757

**Hazen**  
 HAZEN AND SAWYER  
 4000 HOLLYWOOD BOULEVARD, SUITE 750N  
 HOLLYWOOD, FLORIDA 33021

THE SCALE BAR  
 SHOWN BELOW  
 MEASURES ONE  
 INCH LONG ON  
 THE ORIGINAL  
 DRAWING.

CONTRACT:	-
CLIENTS PROJECT:	22-9525
ENGINEERS PROJECT:	4321-095
CAD REFERENCE:	4321-073102

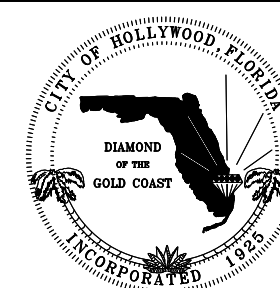

CITY OF HOLLYWOOD

SOUTHERN REGIONAL WASTEWATER TREATMENT PLANT  
 CLARIFIER No. 3 REPAIR

INSTRUMENTATION AND CONTROLS DETAILS

DATE: JANUARY 2023  
 SHEET: 17 OF 17  
 DRAWING: I-3

BID SET