



# CITY OF HOLLYWOOD, FLORIDA

## PROCUREMENT SERVICES DIVISION

### Piggybacking Request Form

(Use for purchase(s) over \$15,000, when piggybacking off other contracts)

Date: July 27, 2016

Department/Office: Public Works

Division/Area: Fleet Maintenance

Contact Person: Joel Wall / Sylvia Glazer

Title: Fleet Coordinator / Public Works Director

Phone: 954.967.4555 / 954.967.4526

Email: [jwall@hollywoodfl.org](mailto:jwall@hollywoodfl.org) / [sglazer@hollywoodfl.org](mailto:sglazer@hollywoodfl.org)

2016 AUG -1 PM 3:54  
CITY OF HOLLYWOOD-  
PROCUREMENT SERVICES  
DIVISION

1. Requested Vendor: Rechtien International Truck, Inc. Vendor Number: 5761

Address: 3787 Interstate Park Rd., Riviera Beach, FL 33404

Contact Person: John Bradley

Title: Governmental Sales Manager

Phone: 561-882-9050

Email: [bradley@rechtien.com](mailto:bradley@rechtien.com)

2. Contract title requesting to piggyback?

Awarding Agency: Florida Sheriffs Association Contract Bid Award (15-13-0904).

Contract Expiration Date: September 30, 2016

Copy of Contract and Awarding Agency documentation is attached.  Yes  No

3. Product/Service being requested (be specific). (1) 2017 International Durastar 4300 SBA (4x2) w/Altec AT40G Telescoping/Articulating Aerial Device, Specification #11.

4. Detailed description of the products/services function and purpose. The Urban Forestry Division seeks authorization to purchase the 2017 International Durastar 4300 SBA (4x2) w/Altec AT40G Telescoping/Articulating Aerial Device (Bucket Truck) to replace the existing 1999 Altec TA40 Aerial Truck that has reached its useful life expectancy. This truck will perform removal of brush from City rights-of-way, debris from vehicular accidents and natural disasters as well as brush from City crew tree trimming. 2017 International

*Procurement Service Division use only*

Requisition # R  
BPO \_\_\_\_\_  
(As Applicable)

Purchase Order # P 219815  
(As Applicable)

Blanket Purchase Order # \_\_\_\_\_  
(As Applicable)

Durastar 4300 SBA (4x2) w/Altec AT40G Telescoping/Articulating Aerial Device was tested to best perform for the needed requirements in the daily operations of the Public Works Urban Forestry Division.

5. Please explain what process the Department/Office took to verify and/or identify this contract. Recommended by the Public Works Department. This vehicle purchase supersedes a previous order #R237690 which was approved by Commission on April 6, 2016, Agenda #R-2016-091, and due to a Manufacturer production cut-off date on this previously requested model, it became no longer available.

6. Were alternative contracts evaluated to determine that the City is obtaining the most advantageous contract pricing for the required product/service?

Yes  No

Please explain This is the best price going for this vehicle and pricing is based on the Florida Sheriff's Association Contract. The State of Florida Contract did not bid on this model vehicle for this year's contract.

7. Total cost of the requested product/service. \$140,158.00

8. Total estimated annual (fiscal year) cost of requested product/service. (1) vehicle = \$140,158.00  
Account Number # 57.5100.14106.590.056452

9. Is this product/service covered by a warranty?  Yes  No

If yes, please attach a copy of the warranty details.

10. Would this purchase(s) result in the potential of future purchases for related products/services being restricted to a particular vendor or create a specific vendor as sole source provider for related items?

Yes  No

If yes, please describe the related products/services and estimated cost(s.) \_\_\_\_\_

11. Would this purchase(s) result in any future maintenance costs which are not included in the initial purchase?

Yes  No

If yes, please attach a draft maintenance plan which includes cost estimates and funding source(s.)  
\_\_\_\_\_

12. Is this a grant related purchase?  Yes  No

If yes, please provide details (timeline, expiration dates, milestones, special procurement requirements, etc.)

Will this require matching funds?  Yes  No

What is the grant source? N/A

What is the grant (dollar) amount? N/A

13. Please complete an advanced search of the vendor recommended for award on the Federal Government's Excluded Parties List System at [www.epls.gov](http://www.epls.gov).

*Procurement Service Division use only*

Requisition # R \_\_\_\_\_  
BPO \_\_\_\_\_  
(As Applicable)

Purchase Order # P 219815  
(As Applicable)

Blanket Purchase Order # \_\_\_\_\_  
(As Applicable)

Date of Advanced Search \_\_\_\_\_

Company Name(s) Searched \_\_\_\_\_

Search Results \_\_\_\_\_

\_\_\_\_\_

\_\_\_\_\_

\_\_\_\_\_

\_\_\_\_\_

\_\_\_\_\_

\_\_\_\_\_

\_\_\_\_\_

\_\_\_\_\_

### REQUESTING DEPARTMENT RECOMMENDATION

**Note: By signing and returning this form, you are verifying and acknowledging that you have reviewed all portions (scope, terms, conditions, pricing, etc.) of the requested contract and recommend its approval based on the contract complying with the City of Hollywood's scope and pricing requirements and to the best of you knowledge the contract does not violate any applicable policy, statute, governing rule or regulation.**

  
Contact Person's Signature

5/27/16  
Date



  
Supervisor's Signature

7/27/16  
Date

  
Director's Signature

7/27/16  
Date

### APPROVAL (Procurement Service Division Use Only)

Verified By:		Date	<u>8/4/16</u>
Approved By:		Date	<u>8/2/2016</u>

*Procurement Service Division use only*

Requisition # R \_\_\_\_\_  
BPO \_\_\_\_\_  
(As Applicable)

Purchase Order # P 219815  
(As Applicable)

Blanket Purchase Order # \_\_\_\_\_  
(As Applicable)



Rechtien International Trucks, Inc

**FLORIDA SHERIFF'S ASSOCIATION Contract 15-13-0904**

Customer: City of Hollywood

Specification: 11 Region: Southern

Base Price:	Quantity	Unit Cost	extended
	1	\$ 58,223.00	\$58,223.00
<b>Contract Options:</b>			
O4085 Hydraulic brakes in lieu of air brakes	1	\$ (357.00)	\$ (357.00)
12EEW Cummins ISB 300 HP diesel engine	1	\$ 4,457.00	\$ 4,457.00
16WJU Power windows and door locks	1	\$ 345.00	\$ 345.00
3K Third key - dealer provided	1	\$ 18.00	\$ 18.00
16JNT Air ride (self contained) driver seat and 2-man passenger seat	1	\$ 630.00	\$ 630.00
14WAP Rear shock absorbers	1	\$ 87.00	\$ 87.00
8HAH Trailer towing package for electric operated trailer brakes	1	\$ 579.00	\$ 579.00
08XAH Manual reset circuit breakers in lieu of fuses	1	\$ 93.00	\$ 93.00
08THB Back-up alarm	1	\$ 113.00	\$ 113.00
O8718 Auxiliary power source - plug in receptacle	1	\$ 28.00	\$ 28.00
08WXB Headlights on warning buzzer -	1	\$ 46.00	\$ 46.00
08WRP Headlights on with wipers - automatically	1	\$ 21.00	\$ 21.00
40LNV Extended vehical coverage 60-mos or 150,000 mi. - excluding engine & transmission	1	\$ 1,950.00	\$ 1,950.00
40KDS Extended engine coverage 60-mos or 150,00 mi. includes after-treatment system	1	\$ 2,760.00	\$ 2,760.00
<b>Non-Contract Options:</b>			
AT40G Altec model AT40G telescoping aerial device per quote 311264	1	\$ 72,339.00	\$ 72,339.00
13ATC Allison 1000 RDS transmission (includes PTO gear)	1	\$ (798.00)	\$ (798.00)
195GVWR 19,500 lbs. GVWR package	1	\$ (3,379.00)	\$ (3,379.00)
5YREXT 5-Year extended warranty for labor, material, and expenses (No Travel) for an Altec AT37G or AT40G aerial device	1	\$ 2,397.00	\$ 2,397.00
GATORHYDE Spray on Gatorhyde bed liner in lieu of non-skid	1	\$ 606.00	\$ 606.00
<i>Extimated delivery of completed unit is 270 to 300 days ARO</i>			
<b>Total:</b>		\$ 140,158.00	\$ 140,158.00
		**Florida Waste Tire Fee	\$ -
		**Florida Waste Battery Fee	\$ -
<b>Total Purchase Order Amount:</b>		\$ 140,158.00	\$ 140,158.00

Cab Color:	White
Body Color:	N/A

\*\*included in base price

Prepared By:  
 John Bradley  
 Rechtien International Trucks, Inc.  
 3787 Interstate Park Road  
 Riviera Beach, FL 33404  
 office - 561.882.9050  
 fax - 561.882.0218  
 cell - 561.818.4374  
 email - bradley@rechtien.com

# ***BID AWARD ANNOUNCEMENT***

# **15-13-0904**

***Effective Dates:***

***October 1, 2015– September 30, 2016***

**Cab & Chassis Trucks  
& Other Fleet Equipment**

***Participating Sheriffs Offices & Local Governmental  
Agencies of the State of Florida***

*Coordinated By*

**The  
Florida Sheriffs Association  
& Florida Association of Counties**





**FLORIDA SHERIFFS ASSOCIATION  
& FLORIDA ASSOCIATION OF COUNTIES**

**25,500 LB. GVWR CAB & CHASSIS (DUAL REAR WHEEL) - 4X2**

**SPECIFICATION #11**

**2017 International Durastar**

The International Durastar purchased through this contract comes with all the standard equipment as specified by the manufacturer for this model and FSA's base vehicle specification(s) requirements which are included and made a part of this contract's vehicle base price as awarded by specification by zone.

ZONE:	Western	Northern	Central	Southern
BASE PRICE:	\$60,947.00	\$59,947.00	\$58,330.00	\$58,223.00

While the Florida Sheriffs Association and Florida Association of Counties have attempted to identify and include those equipment items most often requested by participating agencies for full size vehicles, we realize equipment needs and preferences are going to vary from agency to agency. In an effort to incorporate flexibility into our program, we have created specific add/delete options which allow the purchaser to tailor the vehicle to their particular wants or needs.

The following equipment delete and add options and their related cost are provided here to assist you in approximating the total cost of the type vehicle(s) you wish to order through this program. Simply deduct the cost of any of the following equipment items you wish deleted from the base unit cost and/or add the cost of any equipment items you wish added to the base unit cost to determine the approximate cost of the type vehicle(s) you wish to order.

NOTE: An official listing of all add/delete options and their prices should be obtained from the appropriate dealer in your zone when preparing your order. Additional add/delete options other than those listed here may be available through the dealers, however, those listed here must be honored by the dealers in your zone at the stated prices.

<b>VEHICLE:</b>	Durastar			
<b>DEALER:</b>	Maudlin International Trucks, LLC	Maudlin International Trucks, LLC	Sun State International Trucks	Rechtien International Trucks, Inc
<b>ZONE:</b>	Western	Northern	Central	Southern
<b>BASE PRICE:</b>	\$60,947.00	\$59,947.00	\$58,330.00	\$58,223.00

Order Code	Delete Options	Western	Central	Southern
		& Northern		
	Gas engine in lieu of diesel	NA	NA	NA
	Provide 5 speed manual with base engine - specify	NA	NA	NA
13GNG <sup>1</sup>	Provide 6 speed manual with base engine - specify	\$1,700.00 <sup>1</sup>	\$520.00 <sup>2</sup>	\$1,820.00 <sup>3</sup>
13GMS <sup>2</sup>	Fuller FS-5406N <sup>1</sup>			
13GMS <sup>3</sup>	FULLER FS-6406n: 6 SPEED MANUAL: FULLY SYNCHRONIZED, SHORT SHIFT STROKE <sup>2</sup>			
	Fuller FS-6406N 6-speed manual. Includes factory option codes 13WLA, 12UYB, and 11LEY. <sup>3</sup>			
13GBY <sup>1</sup>	Provide 7 speed manual with base engine - specify	NC <sup>1</sup>	NA	NA
	Eaton EDCO-6F107A <sup>1</sup>			
D4085 <sup>1</sup>	Air brakes if compatible with transmission	\$400.00 <sup>1</sup>	\$370.00 <sup>2</sup>	\$357.00 <sup>3</sup>
4085 <sup>2</sup>	N/A with SA615. <sup>3</sup>			
04085 <sup>3</sup>				
S29001 <sup>1</sup>	Wheel seals	\$20.00 <sup>1</sup>	\$38.00 <sup>2</sup>	\$35.00 <sup>3</sup>
529001 <sup>2</sup>				
529001 <sup>3</sup>				
	Handling package	NA	NA	NA
D8RBK <sup>1</sup>	AM/FM stereo radio	\$175.00 <sup>1</sup>	\$300.00 <sup>2</sup>	\$195.00 <sup>3</sup>
D8RKB <sup>2</sup>				
DK8RKB <sup>3</sup>				
	Satellite radio	NA	NA	NA
	On-Star	NA	NA	NA

Order Code	Add Options	Western	Central	Southern
		& Northern		
12EES <sup>1</sup>	Engine/transmission upgrade - specify	\$1,555.00 <sup>1</sup>	\$1,605.00 <sup>2</sup>	\$1,539.00 <sup>3</sup>
12EES <sup>2</sup>	Cummins ISB 240 HP <sup>1</sup>			
12EES <sup>3</sup>	cummins ISB 240HP engine with 2100 RDS Transmission <sup>2</sup>			
	Cummins ISB 240 HP with 560 ft/lb torque <sup>3</sup>			
12EEU <sup>1</sup>	Engine/transmission upgrade - specify	\$3,157.00 <sup>1</sup>	\$2,946.00 <sup>2</sup>	\$3,124.00 <sup>3</sup>
12EEU <sup>2</sup>	Cummins ISB 260 HP <sup>1</sup>			
12EEU <sup>3</sup>	cummins ISB 260HP engine with 2100 RDS Transmission <sup>2</sup>			
	Cummins ISB 260 HP with 660 ft/lb torque <sup>3</sup>			
12EEV <sup>1</sup>	Engine/transmission upgrade - specify	\$3,867.00 <sup>1</sup>	\$3,988.00 <sup>2</sup>	\$4,457.00 <sup>3</sup>
12EEW <sup>2</sup>	Cummins ISB 280 HP <sup>1</sup>			
12EEW <sup>3</sup>	cummins ISB 300HP engine with 2100 RDS Transmission <sup>2</sup>			
	Cummins ISB 300 HP with 660 ft/lb torque <sup>3</sup>			
12EEW <sup>1</sup>	Engine/transmission upgrade - specify	\$4,504.00 <sup>1</sup>	\$7,152.00 <sup>2</sup>	\$9,048.00 <sup>3</sup>
12EEV <sup>2</sup>	Cummins ISB 300 HP <sup>1</sup>			
12EGA <sup>3</sup>	Cummins ISB 280 HP W/3000 RDS ALLISON TRANSMISSION <sup>2</sup>			
	Cummins ISB 325 HP with 750 ft/lb torque. Includes order code 13AVR or 13AVL <sup>3</sup>			

<b>VEHICLE:</b>	Durastar			
<b>DEALER:</b>	Maudlin International Trucks, LLC	Maudlin International Trucks, LLC	Sun State International Trucks	Rechtien International Trucks, Inc
<b>ZONE:</b>	Western	Northern	Central	Southern
<b>BASE PRICE:</b>	\$60,947.00	\$59,947.00	\$58,330.00	\$58,223.00

12NWK <sup>1</sup> 12EEW <sup>2</sup> 12NWC <sup>3</sup>	Engine/transmission upgrade - specify <i>International N-9 275 HP with model up-grade to 4400 and 3000 series transmission</i> <sup>1</sup> <i>Cummins ISB 300 hp W/3000 RDS ALLISON TRANSMISSION</i> <sup>2</sup> <i>Navistar N9 with SCR, 300 HP with 860 ft/lb torque. Includes order code 13AVR or 13AVL.</i> <sup>3</sup>	\$12,250.00 <sup>1</sup>	\$7,562.00 <sup>2</sup>	\$12,787.00 <sup>3</sup>
12NWC <sup>1</sup> 12EGA <sup>2</sup> 12NWE <sup>3</sup>	Engine/transmission upgrade - specify <i>International N-9 300 HP with model up-grade to 4400 and 3000 series transmission</i> <sup>1</sup> <i>Cummins ISB 325 hp W/3000 RDS ALLISON TRANSMISSION</i> <sup>2</sup> <i>Navistar N9 with SCR, 330 HP with 950 ft/lb torque. Includes order code 13AVR or 13AVL.</i> <sup>3</sup>	\$12,545.00 <sup>1</sup>	\$8,022.00 <sup>2</sup>	\$13,801.00 <sup>3</sup>
12NWE <sup>1</sup> 13ATH <sup>2</sup> 13ATH <sup>3</sup>	Engine/transmission upgrade - specify <i>International N-9 330 HP with model up-grade to 4400 and 3000 series transmission</i> <sup>1</sup> <i>Allison 2500 RDS IN LIEU OF 2100 Allison RDS</i> <sup>2</sup> <i>Allison 2500 RDS in lieu of 2100 RDS transmission</i> <sup>3</sup>	\$13,350.00 <sup>1</sup>	\$70.00 <sup>2</sup>	\$62.00 <sup>3</sup>
13AVR <sup>1</sup> 13AVJ <sup>2</sup> 13AVR <sup>3</sup>	Engine/transmission upgrade - specify <i>Allison 3000 RDS transmission</i> <sup>1</sup> <i>Allison 3000 RDS or 3500 RDS ( order code 13AVL) in lieu of 2100 Allison RDS</i> <sup>2</sup> <i>Allison 3000 RDS in lieu of 2100 RDS transmission. Includes factory option code 13WLP.</i> <i>For Allison 3500 RDS in lieu of 2100 RDS use order code 13AVL.</i> <sup>3</sup>	\$4,860.00 <sup>1</sup>	\$4,185.00 <sup>2</sup>	\$4,256.00 <sup>3</sup>
	Bi-fuel model - specify	NA	NA	NA
	CNG model - specify	NA	NA	NA
	CNG conversion (discuss with dealer)	NA	NA	NA
	LPG conversion (discuss with dealer)	NA	NA	NA
	Engine hour meter	Std	NA	Std
16HGH <sup>1</sup> 16HGH <sup>2</sup> 16HGH <sup>3</sup>	Trans oil temp meter <i>For use with Allison automatic transmission only</i> <sup>3</sup>	\$45.00 <sup>1</sup>	\$40.00 <sup>2</sup>	\$45.00 <sup>3</sup>
13WLN <sup>3</sup>	Allison authorized synthetic oil, TES 295 or equivalent (required for extended warranty) <i>INCLUDED WITH ALLION TRANSMISSION</i> <sup>2</sup> <i>Standard with Allison automatic transmission</i> <sup>3</sup>	Std	Incl. <sup>2</sup>	NC <sup>3</sup>
15DZU <sup>1</sup> 15DMW <sup>2</sup> 15DZU <sup>3</sup>	Premium hoses Dual 45 gallon fuel tanks <i>DUAL 50 GALLON ALUMINUM FUEL TANKS</i> <sup>2</sup> <i>Dual 50 gallon aluminum fuel tanks. Mounted Under Cab Left Side, and Back of Cab Right Side</i> <sup>3</sup>	\$1,057.00 <sup>1</sup>	\$1,100.00 <sup>2</sup>	\$997.00 <sup>3</sup>
4EBT <sup>1</sup> 4EDT <sup>2</sup> 04EBT <sup>3</sup>	Air dryers <i>bendix AD-IP or equal air dryer</i> <sup>2</sup> <i>Bendix AD-IP air dryer or equal</i> <sup>3</sup>	\$500.00 <sup>1</sup>	\$520.00 <sup>2</sup>	\$494.00 <sup>3</sup>
4722 <sup>1</sup> 4722 <sup>2</sup> 04722 <sup>3</sup>	Moisture ejectors <i>bendix DV02 automatic, moisture ejector in wet tank</i> <sup>2</sup> <i>Bendix DV-2 Automatic; With Heater</i> <sup>3</sup>	\$112.00 <sup>1</sup>	\$105.00 <sup>2</sup>	\$112.00 <sup>3</sup>
	Power windows, only	NA	NA	NA



<b>VEHICLE:</b>	Durastar			
<b>DEALER:</b>	Maudlin International Trucks, LLC	Maudlin International Trucks, LLC	Sun State International Trucks	Rechtien International Trucks, Inc
<b>ZONE:</b>	Western	Northern	Central	Southern
<b>BASE PRICE:</b>	\$60,947.00	\$59,947.00	\$58,330.00	\$58,223.00

16WJU <sup>1</sup> 16WJU <sup>2</sup> 16WJU <sup>3</sup>	<b>Power windows/door locks</b> use order code 16WJV for 4-door crew cab - Price \$608.00 <sup>3</sup>	\$349.00 <sup>1</sup>	\$360.00 <sup>2</sup>	\$345.00 <sup>3</sup>
5708 <sup>1</sup> 5708 <sup>2</sup> 05708 <sup>3</sup>	Speed control Tilt steering wheel Tilt steering column <sup>3</sup>	Std \$119.00 <sup>1</sup>	Std \$120.00 <sup>2</sup>	Std \$117.00 <sup>3</sup>
5710 <sup>1</sup> 5719 <sup>2</sup> 05710 <sup>3</sup>	Telescopic and tilt steering wheel Telescopic and tilt steering column <sup>3</sup>	\$312.00 <sup>1</sup>	\$320.00 <sup>2</sup>	\$308.00 <sup>3</sup>
8RME <sup>1</sup> 8RME <sup>2</sup> 08RME <sup>3</sup>	AM/FM radio with single CD AM/FM/WB/Clock/3MM Auxiliary Input, with Multiple Speakers, With CD Player <sup>3</sup>	\$160.00 <sup>1</sup>	\$470.00 <sup>2</sup>	\$446.00 <sup>3</sup>
3K <sup>1</sup> 3K <sup>2</sup> 3K <sup>3</sup>	Side air bags Third key dealer provided <sup>3</sup>	NA \$15.00 <sup>1</sup>	NA \$20.00 <sup>2</sup>	NA \$18.00 <sup>3</sup>
SR515 <sup>1</sup> SR515 <sup>3</sup>	Upgrade to 4x4 (specify factory or after market) Factory Workstar with Maxxforce DT 215 engine <sup>1</sup> Factory 4x4. Includes SA615 Workstar model upgrade and factory option codes 04EBT, 13ATH, 02EZH, 13TKH and 16VHG. <sup>3</sup>	\$32,000.00 <sup>1</sup>	NA	\$30,721.00 <sup>3</sup>
SA615 <sup>1</sup> SA615 <sup>2</sup> SA615 <sup>3</sup>	Model upgrade - specify Workstar 7300 with Cummins ISB engine <sup>1</sup> WORKSTAR 4 X 2 INCLUDES ALLISON 2500 RDS TRANSMISSION ( OPTION CODE 13ATH) <sup>2</sup> Workstar in lieu of Durastar. Includes factory option codes 13ATH and 16VHG. <sup>3</sup>	\$2,900.00 <sup>1</sup>	\$3,697.00 <sup>2</sup>	\$4,306.00 <sup>3</sup>
SR615 <sup>2</sup> 16VHG <sup>3</sup>	Model upgrade - specify WORKSTAR 4 X 4 INCLUDES ALLISON 2500 RDS TRANSMISSION ( OPTION CODE 13ATH) <sup>2</sup> Cab Air Ride Suspension for Mid Cab in Lieu of Low Cab Mounting Height (Approx. 4") <sup>3</sup>	NA	\$24,332.00 <sup>2</sup>	\$538.00 <sup>3</sup>
16196 <sup>1</sup> 16196 <sup>2</sup> 16196 <sup>3</sup>	Crew cab (84" CA) 4-door cab with bench seats front and rear. Includes factory option codes 16SMV, 16VHG, and 16WSG. <sup>3</sup>	\$8,940.00 <sup>1</sup>	\$7,290.00 <sup>2</sup>	\$9,086.00 <sup>3</sup>
16CAB <sup>1</sup> 16CAB <sup>2</sup> 16CAB <sup>3</sup>	Super cab (84" CA) 2-door extended cab with fixed individual front driver and passenger seats and rear bench seat. Includes factory option codes 16SMV, 16VHG, 16SMN, 16KAV, and 16WSX. <sup>3</sup>	\$3,670.00 <sup>1</sup>	\$3,024.00 <sup>2</sup>	\$4,998.00 <sup>3</sup>
MH065 <sup>1</sup> MH065 <sup>2</sup> MH025 <sup>3</sup>	Cutaway cab Low profile package DURASTAR LOW PROFILE SERIES IN LIEU OF STANDARD WITH 19.5 TIRES CONTACT DEALER FOR CAB TO AXLE (CA) <sup>2</sup> Durastar lo-orofile series in lieu of standard with 265/75R22.5 tires. Cab to Axle (CA) restricted - contact dealer for availability. <sup>3</sup>	NA \$2,500.00 <sup>1</sup>	NA \$3,325.00 <sup>2</sup>	NA \$2,711.00 <sup>3</sup>

<b>VEHICLE:</b>	Durastar			
<b>DEALER:</b>	Maudlin International Trucks, LLC	Maudlin International Trucks, LLC	Sun State International Trucks	Rechtien International Trucks, Inc
<b>ZONE:</b>	Western	Northern	Central	Southern
<b>BASE PRICE:</b>	\$60,947.00	\$59,947.00	\$58,330.00	\$58,223.00

14TBJ <sup>1</sup> 14TAX <sup>2</sup> 13TBJ <sup>3</sup>	Optional cab and chassis equipment - specify <i>Air Ride</i> <sup>1</sup> <i>AIR RIDE REAR SUSPENSION, NOT AVAILABLE WITH HYDRRAULIC BRAKES MINIMUM CA RESTRICTED</i> <sup>2</sup> <i>Air ride rear suspension. Not available with hydraulic brakes. CA restricted, contact dealer for availability. Includes factory ooption codes 01CAD &amp; 14899.</i> <sup>3</sup>	\$1,720.00 <sup>1</sup>	\$2,379.00 <sup>2</sup>	\$1,784.00 <sup>3</sup>
16JNT <sup>1</sup> 16JNT <sup>2</sup> 16JNT <sup>3</sup>	Optional cab and chassis equipment - specify <i>Air ride drivers seat and two man passenger seat</i> <sup>1</sup> <i>AIR RIDE DRIVER SEAT AND 2 MAN PASSENGER SEAT</i> <sup>2</sup> <i>Air ride driver seat and 2-man passenger seat. Includes factory option code 16SMP</i> <sup>3</sup>	\$657.00 <sup>1</sup>	\$447.00 <sup>2</sup>	\$630.00 <sup>3</sup>
16RPV <sup>1</sup> 16RPV <sup>2</sup> 16RPV <sup>3</sup>	Optional cab and chassis equipment - specify <i>Air ride drivers and passengers seats.</i> <sup>1</sup> <i>AIR RIDE DRIVER AND PASSENGER SEAT</i> <sup>2</sup> <i>Air ride driver seat and passenger seat. Includes factory option code 16JNT</i> <sup>3</sup>	\$595.00 <sup>1</sup>	\$624.00 <sup>2</sup>	\$599.00 <sup>3</sup>
	Left-hand pillar mounted 6" spotlight with clear halogen bulb, dealer installed	NA	NA	NA
	Left & right-hand pillar mounted 6" spotlight with clear halogen bulb, dealer installed	NA	NA	NA
	Vent visors - stick-on style	NA	NA	NA
	Rainshields - flange style	NA	NA	NA
	Spray-in liner (Rhino, Line-X or approved equivalent)	NA	NA	NA
TLbox <sup>1</sup> TBU4818A <sup>2</sup> TBU4818 <sup>3</sup>	Knapheide under body tool boxes or approved equivalent <i>KNAPHEIDE OR EQUAL UNDER BODY TOOL BOX</i> <sup>2</sup> <i>Knapheide or equal under body mounted steel tool box 48" x 18" x 18"</i> <sup>3</sup>	\$450.00 <sup>1</sup>	\$695.00 <sup>2</sup>	\$595.00 <sup>3</sup>
16WSL <sup>1</sup> 16WSL <sup>2</sup> 16WSL <sup>3</sup>	Fender or cowl mounted convex mirrors <i>FENDER MOUNTED CONVEX MIRRORS</i> <sup>2</sup> <i>Fender mounted convex mirrors</i> <sup>3</sup>	\$130.00 <sup>1</sup>	\$130.00 <sup>2</sup>	\$129.00 <sup>3</sup>
8WCL <sup>1</sup> 8WCL <sup>2</sup> 08WCL <sup>3</sup>	Airhorn <i>NOT AVAILABLE WITH HYDRRAULIC BRAKES</i> <sup>2</sup>	\$90.00 <sup>1</sup>	\$90.00 <sup>2</sup>	\$88.00 <sup>3</sup>
Safety <sup>1</sup> SAFETY <sup>2</sup> SAFETY <sup>3</sup>	Safety kit, fire extinguishers & triangles <i>Dealer installed</i> <sup>3</sup>	\$150.00 <sup>1</sup>	\$159.00 <sup>2</sup>	\$150.00 <sup>3</sup>
	Front stabilizer bars	NA	NA	NA
14WAP <sup>1</sup> 14WAP <sup>2</sup> 14WAP <sup>3</sup>	Rear shock absorbers <i>CA RESTRICTED CONTACT DEALER AVAILABITLY</i> <sup>2</sup> <i>CA-Restricted, contact dealer for availability</i> <sup>3</sup>	\$88.00 <sup>1</sup>	\$93.00 <sup>2</sup>	\$87.00 <sup>3</sup>
	Auxiliary rear springs	Std	Incl.	Std
15LKV <sup>1</sup> 15LLH <sup>2</sup> 15LLH <sup>3</sup>	Heated fuel water separator	\$276.00 <sup>1</sup>	\$585.00 <sup>2</sup>	\$614.00 <sup>3</sup>

<b>VEHICLE:</b>	Durastar			
<b>DEALER:</b>	Maudlin International Trucks, LLC	Maudlin International Trucks, LLC	Sun State International Trucks	Rechtien International Trucks, Inc
<b>ZONE:</b>	Western	Northern	Central	Southern
<b>BASE PRICE:</b>	\$60,947.00	\$59,947.00	\$58,330.00	\$58,223.00

Pintle <sup>1</sup> PNTL <sup>2</sup> PNTL <sup>3</sup>	Trailer towing package - specify 30 ton Pintle hook requires 8TMG or 4619 <sup>1</sup> Pintle hook with safety chain rings - dealer installed. Requires order code 04619 or 08HAH <sup>3</sup>	\$1,250.00 <sup>1</sup>	\$924.00 <sup>2</sup>	\$954.00 <sup>3</sup>
8TMG <sup>1</sup> 4619 <sup>2</sup> 04619 <sup>3</sup>	Trailer towing package for air operated trailer brakes Hitch not included <sup>1</sup> INCLUDES LIGHTING PLUG AND GLAD HANDS HITCH NOT INCLUDED <sup>2</sup> Includes factory order code 08HAA and dealer installed lighting plug and glad hands - Hitch not included <sup>3</sup>	\$740.00 <sup>1</sup>	\$770.00 <sup>2</sup>	\$869.00 <sup>3</sup>
4619 <sup>1</sup> 8TMG <sup>2</sup> 08HAH <sup>3</sup>	Trailer towing package for electric operated trailer brakes Hitch not included <sup>1</sup> INCLUDES LIGHTING PLUS AND ELCTRIC BRAKE CONTROLLER-HITCH NOT INCLUDED <sup>2</sup> Includes dealer installed lighting plug and electric brake controller - Hitch not included <sup>3</sup>	\$515.00 <sup>1</sup>	\$730.00 <sup>2</sup>	\$579.00 <sup>3</sup>
Mud <sup>1</sup> 10WPY <sup>2</sup> 10WPY <sup>3</sup>	Mud flaps Dealer installed <sup>3</sup>	\$70.00 <sup>1</sup>	\$60.00 <sup>2</sup>	\$74.00 <sup>3</sup>
26DRA <sup>1</sup> 29007 <sup>2</sup> 29007 <sup>3</sup>	Full size spare tire & rim 11R22.5 base tire. Contact dealer for additional tire sizes. Includes factory option code 26DTJ. <sup>3</sup>	\$700.00 <sup>1</sup>	\$700.00 <sup>2</sup>	\$850.00 <sup>3</sup>
Jack <sup>1</sup> JACK <sup>2</sup>	Jack and wheel wrench	\$370.00 <sup>1</sup>	\$375.00 <sup>2</sup>	NA
	Nitrogen filled tires including spare tire	NA	NA	NA
8WPB <sup>1</sup> 8WPB <sup>2</sup> 08WPB <sup>3</sup>	Daytime running lights	\$55.00 <sup>1</sup>	\$50.00 <sup>2</sup>	\$55.00 <sup>3</sup>
08WZK <sup>3</sup>	Immobilize daytime running lights	NC	Std	Std <sup>3</sup>
Com16 <sup>1</sup> 16DV <sup>2</sup> 16DV96 <sup>3</sup>	16 ft. dry freight van SUPREME OR EQUAL-85" INSIDE HEIGHT X 96" OUTSIDE WIDTH WITH ROLL-UP REAR DOOR REQUIRES 120 CA <sup>2</sup> Aluminum 16' x 96" x 96" inside height <sup>3</sup>	\$8,800.00 <sup>1</sup>	\$8,615.00 <sup>2</sup>	\$8,288.00 <sup>3</sup>
Nap132D <sup>1</sup> 6132D54J <sup>2</sup> 6133HC <sup>3</sup>	Knapheide 6132 utility body or approved equivalent (requires 84" CA) knapheide 6132 or equal 11' utility body <sup>2</sup> Knapheide or equal <sup>3</sup>	\$7,200.00 <sup>1</sup>	\$7,867.00 <sup>2</sup>	\$14,531.00 <sup>3</sup>
go1849-2 <sup>1</sup> 3DB <sup>2</sup> 3DBOX <sup>3</sup>	Heil 2-3 yd. dump body with manual ground control tarp or approved equivalent (requires 84" CA) knapheide or equal 9' dump body with 16" sides <sup>2</sup> Ox or equal. Includes order code DLRPTO <sup>3</sup>	\$10,500.00 <sup>1</sup>	\$11,593.00 <sup>2</sup>	\$14,189.00 <sup>3</sup>
God300 <sup>1</sup> 5DB <sup>2</sup> 5DBOX <sup>3</sup>	5 yd. dump with manual ground control tarp (requires 84" CA) godwin or equal - 10' dump body with 23" sides <sup>2</sup> Ox or equal. Includes order code DLRPTO <sup>3</sup>	\$13,500.00 <sup>1</sup>	\$13,133.00 <sup>2</sup>	\$14,388.00 <sup>3</sup>
PVMX12 <sup>1</sup> 12SB <sup>2</sup> 12SB <sup>3</sup>	12 ft. flat stake body with 40" sides all around (requires 84" CA)	\$4,800.00 <sup>1</sup>	\$5,446.00 <sup>2</sup>	\$8,272.00 <sup>3</sup>

<b>VEHICLE:</b>	Durastar			
<b>DEALER:</b>	Maudlin International Trucks, LLC	Maudlin International Trucks, LLC	Sun State International Trucks	Rechtien International Trucks, Inc
<b>ZONE:</b>	Western	Northern	Central	Southern
<b>BASE PRICE:</b>	\$60,947.00	\$59,947.00	\$58,330.00	\$58,223.00

BR12 <sup>1</sup> 12CD <sup>2</sup> 12CD <sup>3</sup>	12 ft. contractors dump with manual ground control tarp, 14" sides (requires 84" CA) <i>Includes order code DLRPTO<sup>3</sup></i>	\$13,500.00 <sup>1</sup>	\$12,363.00 <sup>2</sup>	\$14,097.00 <sup>3</sup>
PVMX14 <sup>1</sup> 14SB <sup>2</sup> 14SB <sup>3</sup>	14 ft. flat stake body with 40" sides all around (requires 108" CA)	\$5,200.00 <sup>1</sup>	\$6,026.00 <sup>2</sup>	\$8,622.00 <sup>3</sup>
BR14 <sup>1</sup> 14CD <sup>2</sup> 14CS <sup>3</sup>	14 ft. contractors dump with manual ground control tarp, 14" sides (requires 108" CA) <i>Includes order code DLRPTO<sup>3</sup></i>	\$14,200.00 <sup>1</sup>	\$12,914.00 <sup>2</sup>	\$15,019.00 <sup>3</sup>
PVMX16 <sup>1</sup> 16SB <sup>2</sup> 16SB <sup>3</sup>	16 ft. flat stake body with 40" sides all around (requires 120" CA)	\$5,700.00 <sup>1</sup>	\$6,311.00 <sup>2</sup>	\$8,997.00 <sup>3</sup>
BR16 <sup>1</sup> 16CD <sup>2</sup> 16CD <sup>3</sup>	16 ft. contractors dump with manual tarp, 14" sides (requires 120" CA) <i>Includes order code DLRPTO<sup>3</sup></i>	\$14,700.00 <sup>1</sup>	\$13,374.00 <sup>2</sup>	\$15,252.00 <sup>3</sup>
19ROLL <sup>1</sup> 21RB <sup>2</sup> 19RB <sup>3</sup>	19 ft. rollback wrecker with wheel lift (requires 120" CA) <i>vulcan or equal 21' rollback - includes order codes 60aaa &amp; cal20<sup>2</sup></i> <i>19.5 ft. Century 10-Series or equal. Includes order codes CA120, DLRPTO, &amp; 60AAA. Also includes one set of work lights.<sup>3</sup></i>	\$27,000.00 <sup>1</sup>	\$27,221.00 <sup>2</sup>	\$30,124.00 <sup>3</sup>
PVMX20 <sup>1</sup> 20SB <sup>2</sup> 20SB <sup>3</sup>	20 ft. flat stake body with 40" sides all around (requires 156" CA)	\$6,500.00 <sup>1</sup>	\$7,176.00 <sup>2</sup>	\$9,460.00 <sup>3</sup>
COM20 <sup>1</sup> 20DV <sup>2</sup> 20DV <sup>3</sup>	20 ft. van roll up door (requires 156" CA) <i>SUPREME OR EQUAL-91" INSIDE HEIGHT X 96' OUTSIDE WIDTH WITH ROLL-UP REAR DOOR REQUIRES<sup>2</sup></i> <i>Aluminum 20' x 96" x 96" inside height<sup>3</sup></i>	\$10,500.00 <sup>1</sup>	\$10,667.00 <sup>2</sup>	\$9,312.00 <sup>3</sup>
COM24 <sup>1</sup> 24DV <sup>2</sup> 24DV <sup>3</sup>	24 ft. van roll up door (requires 186" CA) <i>SUPREME OR EQUAL-97" INSIDE HEIGHT X 96' OUTSIDE WIDTH WITH ROLL-UP REAR DOOR REQUIRES<sup>2</sup></i> <i>Aluminum 24' x 96" x 96" inside height<sup>3</sup></i>	\$11,300.00 <sup>1</sup>	\$12,024.00 <sup>2</sup>	\$10,042.00 <sup>3</sup>
PVMX24 <sup>1</sup> 24SB <sup>2</sup> 24SB <sup>3</sup>	24 ft. flat stake body with 40" sides all around (requires 186" CA)	\$7,800.00 <sup>1</sup>	\$8,290.00 <sup>2</sup>	\$9,999.00 <sup>3</sup>
16FLATDMP <sup>1</sup> CANROOF-11 <sup>2</sup> COMP <sup>3</sup>	Optional body - specify <i>16 foot flat bed dump<sup>1</sup></i> <i>canapoy roof medium height requires order code 6132d54j- 11' service body<sup>2</sup></i> <i>Boss U1 DUS-120 210 CFM @ 100 PSIG air compressor with air hose reel and steel mounting platform. For use with order code 6169HC<sup>3</sup></i>	\$11,150.00 <sup>1</sup>	\$4,194.00 <sup>2</sup>	\$30,191.00 <sup>3</sup>
Com18 <sup>1</sup> 14CHIP <sup>2</sup> 16ALTRASH <sup>3</sup>	Optional body - specify <i>18 foot van body<sup>1</sup></i> <i>14' aluminum chipper body - requires 108" CA<sup>2</sup></i> <i>16' aluminum trash body with electric tarp. Includes order code DLRPTO. Requires order code CA108<sup>3</sup></i>	\$9,870.00 <sup>1</sup>	\$18,839.00 <sup>2</sup>	\$22,539.00 <sup>3</sup>

<b>VEHICLE:</b>	Durastar			
<b>DEALER:</b>	Maudlin International Trucks, LLC	Maudlin International Trucks, LLC	Sun State International Trucks	Rechtien International Trucks, Inc
<b>ZONE:</b>	Western	Northern	Central	Southern
<b>BASE PRICE:</b>	\$60,947.00	\$59,947.00	\$58,330.00	\$58,223.00

Com22 <sup>1</sup> TL-3 Traffic Attenuator <sup>2</sup> TSM350 <sup>3</sup>	Optional body - specify 22 foot van body <sup>1</sup> Safe Stop 90 HD, with in-cab controls <sup>2</sup> HD Industries 350-80-DHE pothole patcher with secondary auger motor, wacker compactor plate, hyd lift platform, LED arrow board. Includes option code CA120 <sup>3</sup>	\$11,100.00 <sup>1</sup>	\$25,475.00 <sup>2</sup>	\$79,849.00 <sup>3</sup>
Com26 <sup>1</sup> 16SMN <sup>3</sup>	Optional body - specify 26 foot van body <sup>1</sup> Air ride driver seat and fixed passenger seat. Includes factory option code 16JNT <sup>3</sup>	\$12,000.00 <sup>1</sup>	NA	\$455.00 <sup>3</sup>
8WXD <sup>2</sup> 6169HC <sup>3</sup>	Optional body - specify electric horn sounds in repetitive manner when vehicle park brake is "NOT" set, with ignition "OFF" any any door open <sup>2</sup> Knapheide 14' service body with canopy <sup>3</sup>	NA	\$40.00 <sup>2</sup>	\$20,035.00 <sup>3</sup>
108ca <sup>1</sup> CA108 <sup>2</sup> CA108 <sup>3</sup>	Powder coating for utility body 108" cab to axle includes 120,000 psi frame (01CAE) <sup>2</sup> Includes 120,000 PSI frame - factory option codes 01CAE and 01WEH <sup>3</sup>	NA \$515.00 <sup>1</sup>	NA \$518.00 <sup>2</sup>	NA \$494.00 <sup>3</sup>
120ca <sup>1</sup> CA120 <sup>2</sup> CA120 <sup>3</sup>	120" cab to axle includes 120,000 psi frame (01CAE & 01WEC) <sup>2</sup> Includes 120,000 PSI frame - factory option codes 01CAE and 01WEH <sup>3</sup>	\$780.00 <sup>1</sup>	\$789.00 <sup>2</sup>	\$494.00 <sup>3</sup>
138ca <sup>1</sup> CA138 <sup>2</sup> CA138 <sup>3</sup>	138" cab to axle includes 120,000 psi frame (01CAE & 01WEC) <sup>2</sup> Includes 120,000 PSI frame - factory option codes 01CAE and 01WEJ <sup>3</sup>	\$780.00 <sup>1</sup>	\$789.00 <sup>2</sup>	\$812.00 <sup>3</sup>
156ca <sup>1</sup> CA156 <sup>2</sup> CA156 <sup>3</sup>	156" cab to axle includes 120,000 psi frame (01CAE, 01WEC & 01SAL) <sup>2</sup> Includes 120,000 PSI frame - factory option codes 01CAE, 01WEJ, and 01SAL <sup>3</sup>	\$900.00 <sup>1</sup>	\$906.00 <sup>2</sup>	\$921.00 <sup>3</sup>
180ca <sup>1</sup> CA180 <sup>2</sup> CA180 <sup>3</sup>	180" cab to axle includes 120,000 psi frame (01CAE, 01WEC & 01SAL) <sup>2</sup> Includes 120,000 PSI frame - factory option codes 01CAG, 01WEJ, and 01SAL <sup>3</sup>	\$1,050.00 <sup>1</sup>	\$1,100.00 <sup>2</sup>	\$1,238.00 <sup>3</sup>
186ca <sup>1</sup> CA186 <sup>2</sup> CA186 <sup>3</sup>	186" cab to axle includes 120,000 psi frame (01CAE, 01WEC & 01SAL) <sup>2</sup> Includes 120,000 PSI frame - factory option codes 01CAG, 01WEJ, and 01SAL <sup>3</sup>	\$1,050.00 <sup>1</sup>	\$1,100.00 <sup>2</sup>	\$1,238.00 <sup>3</sup>
Wat120 <sup>1</sup> 2KLG <sup>2</sup> 2KLG <sup>3</sup>	2,000 lb. lift gate	\$3,950.00 <sup>1</sup>	\$3,739.00 <sup>2</sup>	\$3,895.00 <sup>3</sup>
12JCK <sup>2</sup>	12 jon jack cab mounted, if available	NA	\$375.00 <sup>2</sup>	NA
AC50K <sup>1</sup> 11CRB <sup>2</sup> 6132HH <sup>3</sup>	Auto Crane 50K-22 crane body with shelf package, 24" bumper with crank outriggers, or approved equivalent Knapheide or equal 11' crane body, 21' bumper with manual outriggers <sup>2</sup> 11' Knapheide crane body <sup>3</sup>	\$23,950.00 <sup>1</sup>	\$19,042.00 <sup>2</sup>	\$34,041.00 <sup>3</sup>
AC60EH <sup>1</sup> EC6000 <sup>2</sup>	Auto Crane 6006EH electric hydraulic crane, boom support & chassis springs, or approved equivalent STELLAR EC6000 OR EQUAL ELECTRIC OVER HYDRAULIC CRANE, REQUIRES CRANE RATED BODY <sup>2</sup>	\$22,500.00 <sup>1</sup>	\$18,174.00 <sup>2</sup>	NA
ACOR <sup>1</sup> OUTR <sup>2</sup>	Auto Crane hydraulic outriggers, or approved equivalent STELLAR OR EQUAL FULLY HYDRAULIC OUTRIGGERS <sup>2</sup>	\$6,200.00 <sup>1</sup>	\$5,879.00 <sup>2</sup>	NA

VEHICLE:	Durastar			
DEALER:	Maudlin International Trucks, LLC	Maudlin International Trucks, LLC	Sun State International Trucks	Rechtien International Trucks, Inc
ZONE:	Western	Northern	Central	Southern
BASE PRICE:	\$60,947.00	\$59,947.00	\$58,330.00	\$58,223.00
ACHC7 <sup>1</sup> 7261 <sup>2</sup> ST7621 <sup>3</sup>	Auto Crane 6406 hydraulic crane, reservoir, PTO and pump, boom supprt & chassis springs, or approved equivalent <i>STELLAR 7621 OR EQUAL HYDRAULIC CRANE, REQUIRES CRANE RATED BODY</i> <sup>2</sup> <i>Stellar 7621 hydraulic crane</i> <sup>3</sup>	\$26,500.00 <sup>1</sup>	\$25,586.00 <sup>2</sup>	\$23,060.00 <sup>3</sup>
ACH8 <sup>1</sup> 9621 <sup>2</sup> ST10621 <sup>3</sup>	Auto Crane 8406 hydraulic crane, reservoir, PTO and pump, boom supprt & chassis springs, or approved equivalent <i>STELLAR 9621 OR EQUAL HYDRAULIC CRANE WITH REMOTE CONTROL REQUIRES CRANE RATED BODY</i> <sup>2</sup> <i>Stellar 10621 hydraulic crane</i> <sup>3</sup>	\$29,500.00 <sup>1</sup>	\$26,163.00 <sup>2</sup>	\$26,157.00 <sup>3</sup>
8THB <sup>1</sup> 8THB <sup>2</sup> 08THB <sup>3</sup>	Backup alarm - Factory Installed	\$115.00 <sup>1</sup>	\$110.00 <sup>2</sup>	\$113.00 <sup>3</sup>
DLRBU <sup>1</sup> DLRBC <sup>2</sup> DLRBA <sup>3</sup>	Backup alarm - Dealer Installed	\$150.00 <sup>1</sup>	\$120.00 <sup>2</sup>	\$120.00 <sup>3</sup>
	Backup camera with 3.5" LCD (rear mounted camera to provide wide angle field of vision at rear of vehicle) - Factory Installed	NA	NA	NA
BUC <sup>1</sup> BUC <sup>2</sup> BUC <sup>3</sup>	Backup camera with 3.5" LCD (rear mounted camera to provide wide angle field of vision at rear of vehicle) - Dealer Installed	\$1,550.00 <sup>1</sup>	\$1,250.00 <sup>2</sup>	\$980.00 <sup>3</sup>
Diflock <sup>1</sup> 16SDC <sup>2</sup> 16SDC <sup>3</sup>	Optional equipment - specify <i>Driver controlled rear axle diff lock</i> <sup>1</sup> <i>EXTERIOR GRAB HANDLE 2-DOOR CAB FOR 4- DOOR CAB (16196) use order code 16sdd add \$472</i> <sup>2</sup> <i>Exterior grab handle(s) for use with standard cab. Use order code 16SDD for 4-door cab (includes 16SDC) - add \$444.00</i> <sup>3</sup>	\$720.00 <sup>1</sup>	\$236.00 <sup>2</sup>	\$222.00 <sup>3</sup>
8XAH <sup>1</sup> DIFLOC <sup>2</sup> 14AHM <sup>3</sup>	Optional equipment - specify <i>Circuit breakers</i> <sup>1</sup> <i>DRIVER CONTROLLED REAR AXLE DIFFERENTIAL LOCK</i> <sup>2</sup> <i>Driver controlled differential lock for rear axle</i> <sup>3</sup>	\$90.00 <sup>1</sup>	\$1,218.00 <sup>2</sup>	\$533.00 <sup>3</sup>
60AAA <sup>1</sup> 8XAH <sup>2</sup> 08XAH <sup>3</sup>	Optional equipment - specify <i>RPM</i> <sup>1</sup> <i>CIRCUIT BREAKERS IN LIEU OF FUSES</i> <sup>2</sup> <i>Manual-Reset Circuit Breakers(Main Panel) SAE Type III With Trip Indicators. Replaces All Fuses Except For 5-Amp Fuses</i> <sup>3</sup>	\$655.00 <sup>1</sup>	\$90.00 <sup>2</sup>	\$93.00 <sup>3</sup>
LEDPKG <sup>1</sup> 8718 <sup>2</sup> 08718 <sup>3</sup>	Optional equipment - specify <i>LED light package</i> <sup>1</sup> <i>AUXILIARY POWER SOURCE - CIGAR LIGHTER TYPE RECEPTABLE</i> <sup>2</sup> <i>Auxiliary power source - cigar type receptacle</i> <sup>3</sup>	\$540.00 <sup>1</sup>	\$20.00 <sup>2</sup>	\$28.00 <sup>3</sup>
7SCP <sup>1</sup> 60AAA <sup>2</sup> 60AAA <sup>3</sup>	Optional equipment - specify <i>Engine exhaust brake</i> <sup>1</sup> <i>REMOTE POWER MODULE FOR BODY BUILDER INTERFACE</i> <sup>2</sup> <i>Remote power module for body builder interface - 6-inputs and 6-outputs with switches on the dash</i> <sup>3</sup>	\$180.00 <sup>1</sup>	\$570.00 <sup>2</sup>	\$649.00 <sup>3</sup>

<b>VEHICLE:</b>	Durastar			
<b>DEALER:</b>	Maudlin International Trucks, LLC	Maudlin International Trucks, LLC	Sun State International Trucks	Rechtien International Trucks, Inc
<b>ZONE:</b>	Western	Northern	Central	Southern
<b>BASE PRICE:</b>	\$60,947.00	\$59,947.00	\$58,330.00	\$58,223.00

8WRP <sup>1</sup> LEDPKG <sup>2</sup> 08WPP <sup>3</sup>	Optional equipment - specify <i>Head lights on with wipers</i> <sup>1</sup> <i>LED LIGHT PACKAGE INCLUDES MARKER LIGHTS, TAIL LIGHTS, BRAKE LIGHTS, AND TAG LIGHTS</i> <sup>2</sup> <i>For use with International brand engines only. Available on Cummins ISB engines at no charge - notify dealer if required.</i> <sup>3</sup>	\$22.00 <sup>1</sup>	\$546.00 <sup>2</sup>	\$138.00 <sup>3</sup>
8WPZ <sup>1</sup> 7SCP <sup>2</sup> 08WXB <sup>3</sup>	Optional equipment - specify <i>Test exterior lights</i> <sup>1</sup> <i>ENGINE EXHAUST BRAKE</i> <sup>2</sup> <i>HEAD LIGHT WARNING BUZZER - Sounds when headlights are on and ignition switch is in the off position</i> <sup>3</sup>	\$40.00 <sup>1</sup>	\$180.00 <sup>2</sup>	\$46.00 <sup>3</sup>
8HAE <sup>1</sup> 8WRP <sup>2</sup> 08WRP <sup>3</sup>	Optional equipment - specify <i>Body builder wiring rear of frame</i> <sup>1</sup> <i>HEADLIGHTS ON WITH WIPERS</i> <sup>2</sup> <i>Headlights on with wipers - automatically</i> <sup>3</sup>	\$200.00 <sup>1</sup>	\$20.00 <sup>2</sup>	\$21.00 <sup>3</sup>
16SDC <sup>1</sup> 8WPZ <sup>2</sup> 08WPZ <sup>3</sup>	Optional equipment - specify <i>Exterior grab handles. Add \$226.00 for crew cab</i> <sup>1</sup> <i>TEST EXTERIOR LIGHTS PRE TRIP EXTERIOR LIGHT INSEPCIONS, FLASHES VEHICILE LIGHTS IN SPECIFIC SEQUENECE FOR WALK AROUND INSPECTION</i> <sup>2</sup> <i>Test Exterior Lights - pre-trip exterior light inspection flashes vehicle lights in specific sequence for walk around inspection</i> <sup>3</sup>	\$226.00 <sup>1</sup>	\$40.00 <sup>2</sup>	\$39.00 <sup>3</sup>
8HAB <sup>2</sup> LEDPKG <sup>3</sup>	Optional equipment - specify <i>BODY BUILDER INTERFACE WIRING FOR LIGHTING</i> <sup>2</sup> <i>LED lighting package for Body and cab &amp; chassis. Includes factory option codes 08TRS, 08WPH, and 08XGT</i> <sup>3</sup>	NA	\$90.00 <sup>2</sup>	\$517.00 <sup>3</sup>
TEMP <sup>1</sup>	Temporary tag	\$15.00 <sup>1</sup>	NA	NA
TRANSFER <sup>1</sup> TRANS TAG <sup>2</sup> TRANSTAG <sup>3</sup>	Transfer existing registration (must provide tag number)	\$95.00 <sup>1</sup>	\$95.00 <sup>2</sup>	\$95.00 <sup>3</sup>
NEW TAG <sup>1</sup> NEW TAG <sup>2</sup> NEWTAG <sup>3</sup>	New state tag (specify state, county, city, sheriff, etc.)	\$150.00 <sup>1</sup>	\$150.00 <sup>2</sup>	\$175.00 <sup>3</sup>
40LNK <sup>1</sup>	Maintenance Plan - specify <i>36 months 150k mile vehicle warranty excludes engine and transmission.</i> <sup>1</sup>	\$1,520.00 <sup>1</sup>	NA	NA
40LNP <sup>1</sup>	Maintenance Plan - specify <i>48 months 150k mile vehicle warranty excludes engine and transmission.</i> <sup>1</sup>	\$2,000.00 <sup>1</sup>	NA	NA
40LNV <sup>1</sup>	Maintenance Plan - specify <i>60 months 150k mile vehicle warranty excludes engine and transmission.</i> <sup>1</sup>	\$2,500.00 <sup>1</sup>	NA	NA
40KDK <sup>1</sup> 40LNK <sup>2</sup> 040LNK <sup>3</sup>	Warranty - specify <i>Cummins PP1 36 months 150K mile engine warranty</i> <sup>1</sup> <i>EXTENDED VEHICLE COVERAGE 36 MONTHS OR 150,000 MILES, EXCLUDES ENGINE &amp; TRANSMISSION</i> <sup>2</sup> <i>Extended Vehicle Coverage - 36 Months or 150,000 Miles. Excludes Engine, Exhaust After-Treatment, and Transmission. For SA615 use order code 040LPH - Price \$1950.00</i> <sup>3</sup>	\$1,750.00 <sup>1</sup>	\$1,520.00 <sup>2</sup>	\$1,170.00 <sup>3</sup>

<b>VEHICLE:</b>	Durastar			
<b>DEALER:</b>	Maudlin International Trucks, LLC	Maudlin International Trucks, LLC	Sun State International Trucks	Rechtien International Trucks, Inc
<b>ZONE:</b>	Western	Northern	Central	Southern
<b>BASE PRICE:</b>	\$60,947.00	\$59,947.00	\$58,330.00	\$58,223.00

40KDL <sup>1</sup> 40LNP <sup>2</sup> 040LNP <sup>3</sup>	<p>Warranty - specify Cummins PPI 48 months 150K mile engine warranty<sup>1</sup></p> <p><b>EXTENDED VEHICLE COVERAGE 48 MONTHS OR 150,000 MILES, EXCLUDES ENGINE &amp; TRANSMISSION<sup>2</sup></b></p> <p><i>Extended Vehicle Coverage - 48 Months or 150,000 Miles. Excludes Engine, Exhaust After-Treatment, and Transmission. For SA615 use order code 040LPM - Price \$2,580.00<sup>3</sup></i></p>	\$2,050.00 <sup>1</sup>	\$1,950.00 <sup>2</sup>	\$1,545.00 <sup>3</sup>
40KDS <sup>1</sup> 40LNV <sup>2</sup> 040LNV <sup>3</sup>	<p>Warranty - specify Cummins PPI 60 months 150K mile engine warranty<sup>1</sup></p> <p><b>EXTENDED VEHICLE COVERAGE 60 MONTHS OR 150,000 MILES, EXCLUDES ENGINE &amp; TRANSMISSION<sup>2</sup></b></p> <p><i>Extended Vehicle Coverage - 60 Months or 150,000 Miles. Excludes Engine, Exhaust After-Treatment, and Transmission. For SA615 use order code 040LPS - Price \$3,315.00<sup>3</sup></i></p>	\$2,350.00 <sup>1</sup>	\$2,500.00 <sup>2</sup>	\$1,950.00 <sup>3</sup>
40KDK <sup>2</sup> 040KDK <sup>3</sup>	<p>Diesel Warranty - specify <b>EXTENDED ENGINE SERVICE CONTRACTS 36 MONTHS 150,000<sup>2</sup></b></p> <p><i>Extended Engine Coverage for Cummins ISB. 36 Months or 150,000 Miles. Includes Exhaust After-Treatment system factory option code 40KGJ. Extended Engine Coverage for Navistar N9. 36 Months, 150,000 Miles, or 5,400 hours use order code 40LBR - Price \$2,160.00. Includes Exhaust After-Treatment System.<sup>3</sup></i></p>	NA	\$1,700.00 <sup>2</sup>	\$2,080.00 <sup>3</sup>
40KDL <sup>2</sup> 040KDL <sup>3</sup>	<p>Diesel Warranty - specify <b>EXTENDED ENGINE SERVICE CONTRACTS 48 MONTHS 150,000<sup>2</sup></b></p> <p><i>Extended Engine Coverage for Cummins ISB. 48 Months or 150,000 Miles. Includes Exhaust After-Treatment system factory option code 40KGK. Extended Engine Coverage for Navistar N9. 48 Months, 150,000 Miles, or 5,400 hours use order code 40LBW - Price \$3,900.00 Includes Exhaust After-Treatment system factory option code 040KVE.<sup>3</sup></i></p>	NA	\$2,000.00 <sup>2</sup>	\$2,400.00 <sup>3</sup>
40KDS <sup>2</sup> 040KDS <sup>3</sup>	<p>Diesel Warranty - specify <b>EXTENDED ENGINE SERVICE CONTRACTS 60 MONTHS 150,000<sup>2</sup></b></p> <p><i>Extended Engine Coverage for Cummins ISB. 60 Months or 150,000 Miles. Includes Exhaust After-Treatment system factory option code 40KGC. Extended Engine Coverage for Navistar N9. 60 Months, 150,000 Miles, or 5,400 hours use order code 40LCC - Price \$4,725.00 Includes Exhaust After-Treatment system factory option code 040KVM.<sup>3</sup></i></p>	NA	\$2,300.00 <sup>2</sup>	\$2,760.00 <sup>3</sup>



**Prepared For:**  
 City of Hollywood  
 Joel Wall  
 2600 Hollywood Blvd.  
 Hollywood, FL 33020-4800  
 (954)921 - 3290  
 Reference ID: #11 - Hollywood

**Presented By:**  
 RECHTIEN INTERNATIONAL TRUCKS, INC.  
 John W Bradley  
 3787 INTERSTATE PARK ROAD  
 RIVIERA BEACH FL 33404 -  
 (866)882-9050

Thank you for the opportunity to provide you with the following quotation on a new International truck. I am sure the following detailed specification will meet your operational requirements, and I look forward to serving your business needs.

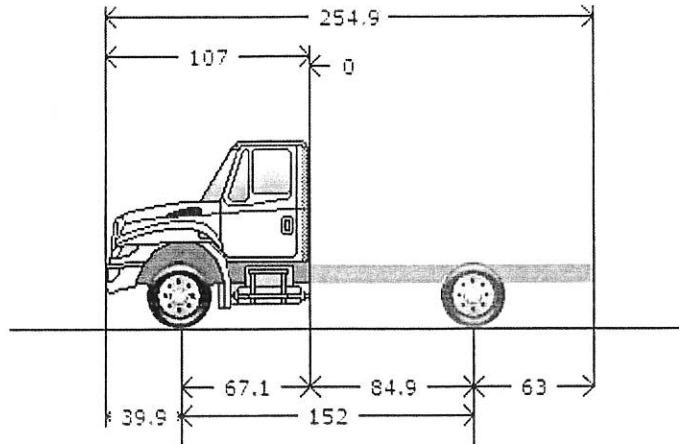

**Model Profile**  
**2017 4300 SBA 4X2 (MA025)**

<b>APPLICATION:</b>	Stake Flat
<b>MISSION:</b>	Requested GVWR: 19500. Calc. GVWR: 19500
<b>DIMENSION:</b>	Wheelbase: 152.00, CA: 84.90, Axle to Frame: 63.00
<b>ENGINE, DIESEL:</b>	{Cummins ISB 300} EPA 2010, 300 HP @ 2600 RPM, 660 lb-ft Torque @ 1600 RPM, 2600 RPM Governed Speed, 300 Peak HP (Max)
<b>TRANSMISSION, AUTOMATIC:</b>	{Allison 1000_RDS} 5th Generation Controls; Close Ratio, 5-Speed, With Overdrive; Includes Park Pawl, With PTO Provision, Less Retarder, With 19,500-lb GVW & 26,000-lb GCW Max., on/off hwy
<b>CLUTCH:</b>	Omit Item (Clutch & Control)
<b>AXLE, FRONT NON-DRIVING:</b>	{Dana Spicer D800-F} I-Beam Type, 8,000-lb Capacity
<b>AXLE, REAR, SINGLE:</b>	{Dana Spicer S16-130} Single Reduction, 15,500-lb Capacity, 190 Wheel Ends Gear Ratio: 4.30
<b>CAB:</b>	Conventional
<b>TIRE, FRONT:</b>	(2) 245/70R19.5 HSR-1 (CONTINENTAL) 630 rev/mile, load range H, 16 ply
<b>TIRE, REAR:</b>	(4) 245/70R19.5 HDR (CONTINENTAL) 627 rev/mile, load range H, 16 ply
<b>SUSPENSION, RR, SPRING, SINGLE:</b>	Vari-Rate; 13,500-lb Capacity, With 4500 lb Auxiliary Rubber Spring
<b>PAINT:</b>	Cab schematic 100GA Location 1: 9219, Winter White (Std) Chassis schematic N/A

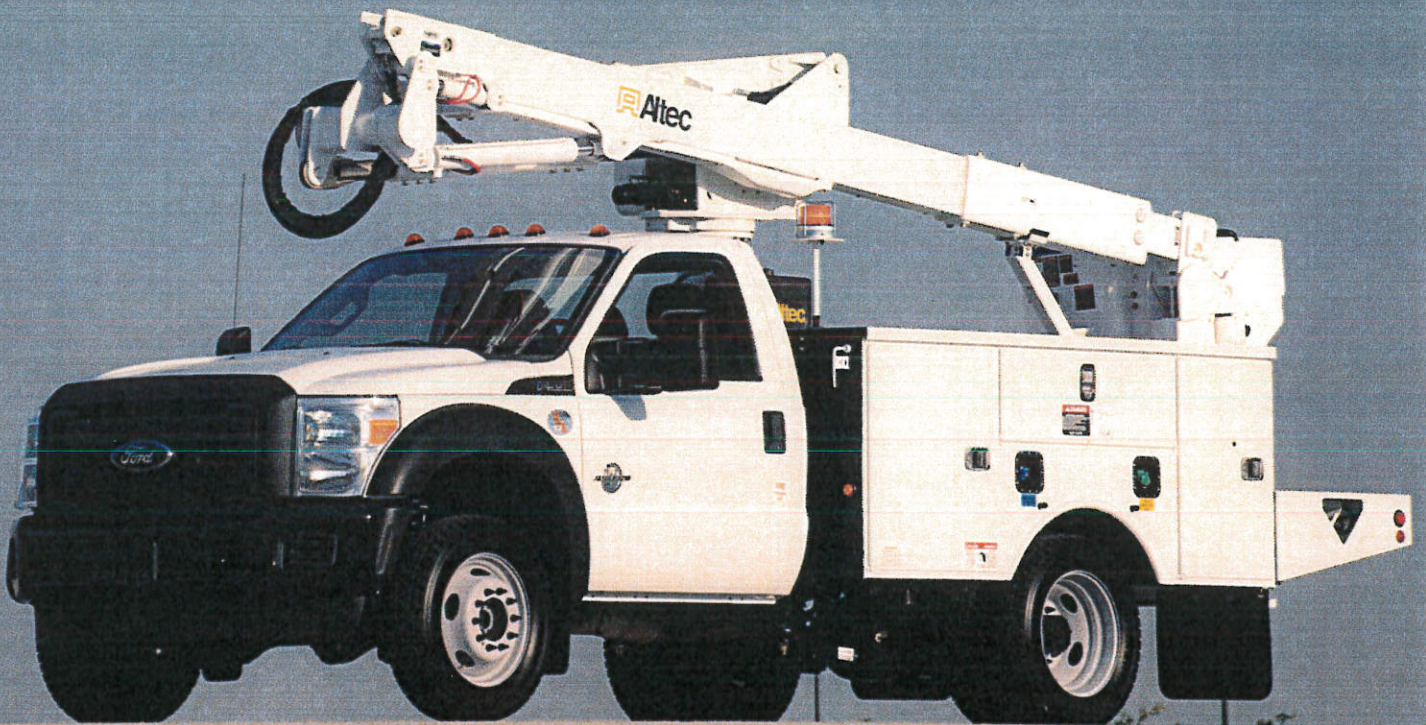

FOR NEW EQUIPMENT SALES, CALL  
**800.958.2555**  
TO SPEAK WITH AN ALTEC REPRESENTATIVE  
or visit us online at [altec.com](http://altec.com)

 **Altec**  
TELESCOPIC ARTICULATING  
AERIAL DEVICE

## FEATURES

- Telescopic Articulating Aerial Device
- Compensated Articulating Arm
- Hydraulic Boom Extension
- Altec ISO-Grip® Control System
- Low Power Fiber Optic Control System
- Fully Metered 4-Function, Single-Handle Upper Control
- Platform Access from Ground
- Composite Platform Mounting Bracket
- Insulating, ANSI Category C
- Hydraulic Platform Leveling System
- Emergency Lowering Valve at Platform
- Platform Leveling at Upper and Lower Controls
- 180° Platform Rotator
- Tool Circuit at Platform
- Open-Center Hydraulic System
- Easily Mounted on 19,500 lb (8,845 kg) GVWR Chassis
- Outrigger Boom Interlock System (with Outrigger Option)
- Outrigger Motion Alarm (with Outrigger Option)
- Back Up Alarm

## OPTIONS

- ISO-Boom Offering ANSI Category C Isolation with Boom Retracted
- Outriggers, Vertical
- Hybrid Adaptation Available with Standard Electronic Systems
- Secondary Stowage
- Engine Start/Stop
- Platform Cover
- Tool Circuit at Tailshelf
- 24 x 24 x 42 in (610 x 610 x 1067 mm) Platform

Recommended safety equipment, available through Altec Supply, include a platform liner, fall protection system, wheel chocks and outrigger pads (with outrigger option).

SPECIFICATIONS	
Ground to Bottom of Platform* (at Reach from Centerline)	40.6 ft (12.4 m) 10.3 ft (3.1 m)
Working Height	45.6 ft (13.9 m)
Maximum Side Reach (at Platform Height)	29.7 ft (9.1 m) 15.2 ft (4.6 m)
Platform Capacity	400 lb (181.4 kg)
Platform Dimensions (End-Mount)	24 x 30 x 42 in (610 x 762 x 1,067 mm)
Articulating Arm Articulation	-5 to 79°
Upper Boom Articulation	-25 to 75°
Stowed Travel Height	10.3 ft (3.1 m)
Rotation	Continuous
Weight of Machine**	2,543 lb (1,153 kg)

\*Based on a 40 in (1016 mm) chassis frame height.  
\*\*Weight does not include mounting frame or outriggers.

## REACH DIAGRAM



**INCREASED SIDE REACH**  
29.7 FT (9.1 M)



**INCREASED WORKING HEIGHT**  
45.6 FT (13.9 M)



**ISO-BOOM OPTION**  
FOR ADDED DIELECTRIC INTEGRITY



**FIBER OPTIC CONTROLS**  
WITH FEWER HOSES AND VALVES



For more complete information on Altec products and services, visit us on the web at [www.altec.com](http://www.altec.com). Material and specifications are subject to change without notice. Featured units in photos may include optional features. Please contact an Altec representative for all available options. Altec® and the Altec logo are registered trademarks of Altec Inc. in the United States and various other countries and may not be used without permission.

© 2015 Altec Inc. All Rights Reserved. A10SAT40G-0313 v1



July 19, 2016  
Our 87th Year

**Ship To:**  
CITY OF HOLLYWOOD  
PUBLIC WORKS DEPT  
1600 S PARK RD  
PO BOX 229045  
HOLLYWOOD, FL 33022-9045  
US

**Bill To:**  
CITY OF HOLLYWOOD  
PUBLIC WORKS DEPT  
1600 S PARK RD  
PO BOX 229045  
HOLLYWOOD, FL 33022-9045  
United States

Attn:  
Phone:  
Email:

**Altec Quotation Number:** 311264 - 4  
**Account Manager:** Jenny Carlson  
**Technical Sales & Support:** Kasey Ruth Tipton

<u>Item</u>	<u>Description</u>	<u>Qty</u>	<u>Price</u>
	<u>Unit</u>		
1.	ALTEC Model AT40-G telescopic articulating Aerial device with ISO-Boom.	1	
	A. ISO Boom: the inner telescopic fiberglass boom maintains full dielectric integrity even with the fiberglass inner boom fully retracted.		
	B. Hydraulic platform leveling system.		
	C. Hydraulic tool circuit at the platform.		
	D. Emergency lowering valve at the platform.		
	E. Single handle control at the platform with a safety interlock system.		
	F. Two (2) operators and maintenance/parts manuals.		
	G. Working height: 45.6 feet		
	H. Side reach: 29.7 feet		
	I. Low-power fiber-optic control system (FOC-L).		
	J. Continuous rotation		
2.	AT40G Unit Model	1	
3.	Post style pedestal mounting	1	
4.	Poly Reservoir, Pedestal Mounted, 7 Gallon; Includes Sight Gauge.	1	
5.	Single One-Man End-Mounted Platform With 180 Degree Rotator, 24 X 30 X 42. Platform is rated at 400 pounds. Control panel on platform dashboard provides controls for auxiliary functions. Includes emergency stop (push-pull) switch and rocker switches, which operate platform leveling, platform rotation, tools, and battery selector (for fiber-optic controls system). Composite fiberglass platform mounting bracket. (AT40G)	1	
6.	Platform Leveling At Lower Controls. AT40-G	1	
7.	Two (2) Platform Steps	1	

We Wish To Thank You For Giving Us The Pleasure  
And Opportunity of Serving You

<u>Item</u>	<u>Description</u>	<u>Qty</u>	<u>Price</u>
8.	Soft nylon reinforced vinyl platform cover for a 24 x 30 inch platform	1	
9.	Platform liner for a 24 x 30 x 42 inch platform	1	
10.	4-Function Single Handle Fiber-Optic Controller.	1	
11.	Engine Start/Stop at the upper controls actuated through the Fiber-Optic controls system with Secondary Stowage System (AT40G)	1	
12.	Manual lowering valve located at the boomtip. For use in emergency situations to allow the operator to lower the boom to the ground	1	
13.	Powder coat unit Altec White.	1	
<b><u>Unit &amp; Hydraulic Acc.</u></b>			
14.	HVI-22 Hydraulic Oil (Standard).	9	
15.	Standard Pump For PTO	1	
16.	Hot shift PTO for automatic transmission	1	
<b><u>Body</u></b>			
17.	132 Inch Universal Small Aerial Body for an 84 Inch CA Chassis with 29 Inch Long Side Access Tailshelf to Meet the Following Specifications:	1	
A.	Basic body fabricated from A40 grade 100% zinc alloy coated steel		
B.	All doors are full, double paneled, self-sealed with built-in drainage.		
C.	Electro-zinc plated, steel hinge rods extend full length of door.		
D.	Door hinges are zinc alloy material attached with rivets		
E.	All doors contain stainless steel, flush mounted, paddle activated rotary style latches with two-stage locking, including keyed locks and adjustable strikers.		
F.	Heavy-gauge welded steel frame construction with smooth galvaneal floor.		
G.	All edges are either rolled or folded for strength and safety		
H.	Door header drip rail at top for maximum weather protection.		
I.	Neoprene or rolled fenders on wheel fender panels.		
J.	Steel treated for improved primer bond and rust resistance.		
K.	Automotive underseal applied to body.		
L.	Automotive type non-porous door seals mechanically fastened to the door facing		
M.	132 Inch Body Length		
N.	40 Inch Body Height (Standard)		
O.	94 Body Width (Standard)		
P.	20 Inch Body Compartment Depth (Standard)		
Q.	Body Color - White (Standard)		
R.	Finish Paint Body At Body Manufacturer (Standard)		
S.	8 Inch Body Crossmembers (Standard)		
T.	6 Inch tall wood tailboard installed at the rear of body cargo area		
U.	No Compartment Lighting Supplied by the Body Manufacturer		
V.	Stainless Steel Rotary Paddle Latch With Lock (Standard)		
W.	Master Body Locking System (Standard)		

We Wish To Thank You For Giving Us The Pleasure  
And Opportunity of Serving You

<u>Item</u>	<u>Description</u>	<u>Qty</u>	<u>Price</u>
X.	No Chock Holders In Line Body Fender Panel Required (Standard)		
Y.	Gas Shock Type Rigid Door Holders For Vertical Doors (Standard)		
Z.	Chains On Horizontal Doors		
AA.	No Hotstick Shelf Required		
AB.	No Hotstick Door Required		
AC.	1st Vertical Street Side (LH) - Three (3) Adjustable Shelf With Removable Dividers On 2 Inch Centers		
AD.	2nd Vertical Street Side (LH) - Three (3) Adjustable Shelf With Removable Dividers On 2 Inch Centers		
AE.	1st Horizontal Street Side (LH) - One (1) Fixed Shelf With Removable Dividers On 4 Inch Centers		
AF.	Rear Vertical Street Side (LH) - Three (3) Adjustable Shelf With Removable Dividers On 2 Inch Centers		
AG.	1st Vertical Curb Side (RH) - Three (3) Adjustable Shelf With Removable Dividers On 2 Inch Centers		
AH.	1st Vertical Curb Side (RH) - Louvered Panel On Inside Cargo Wall		
AI.	2nd Vertical Curb Side (RH) - Three (3) Adjustable Shelf With Removable Dividers On 2 Inch Centers		
AJ.	1st Horizontal Curb Side (RH) - One (1) Fixed Shelf With Removable Dividers On 4 Inch Centers		
AK.	Rear Vertical Curb Side (RH) - Three (3) Adjustable Shelf With Removable Dividers On 2 Inch Centers		
AL.	Aluminum Rock Guards Installed at Bottom		
AM.	29" Tailshelf with Integrated Side Access Steps, Two Wheel Chock Holders, and Smooth Galvaneal Floor Installed at Rear of Body		

**Body and Chassis Accessories**

18.	ICC Underride Protection	1	
19.	Combination 2 Ball (10,000 LB MGTW) And Pintle Hitch (16,000 LB MGTW)	1	
20.	Set Of Eye Bolts for Trailer Safety Chain, installed one each side of towing device mount.	1	
21.	Front Torsion Bar Installed On Chassis	1	
22.	Rear Torsion Bar Installed On Chassis	1	
23.	Appropriate counterweight added for stability.	1	
24.	Cable Step Installed At Rear, Single Step	1	
25.	Platform Rest, Rigid with Rubber Tube	1	
26.	Boom Rest for a Telescopic Unit	1	
27.	Mud Flaps With Altec Logo (Pair)	1	
28.	Wheel Chocks, Rubber with Metal Hairpin Style Handle, 9.75" L X 7.75" W X 5.00" H (Pair)	1	
29.	U-Shaped Grab Handle	1	

We Wish To Thank You For Giving Us The Pleasure  
And Opportunity of Serving You

UTILITY EQUIPMENT AND BODIES SINCE 1929

<u>Item</u>	<u>Description</u>	<u>Qty</u>	<u>Price</u>
30.	Small Grab Handle Installed At Rear	1	
31.	Slope Indicator Assembly For Machine Without Outriggers	1	
32.	Safety Harness & 4.5 FT Lanyard (Medium To X-large)	1	
33.	5 LB Fire Extinguisher With Light Duty Bracket, Installed Per DEPS 042 (In Cab or Inside Compartment Only)	1	
34.	Triangular Reflector Kit, Installed	1	
35.	Soft Vinyl Lanyard Pouch	1	
36.	Vinyl manual pouch for storage of all operator and parts manuals	1	
<b><u>Electrical Accessories</u></b>			
37.	Lights and reflectors in accordance with FMVSS #108 lighting package. (Complete LED, including LED reverse lights)	1	
38.	Altec Standard Amber LED Strobe Light with Brush Guard Post mounted on SS front of body	1	
39.	4-Corner Strobe Lighting, Amber LED, Two (2) Oval Lights Mounted in Front Grille and Two (2) Round Lights Mounted at Rear	1	
40.	Single tone back up alarm installed between the chassis frame rails at the rear of the chassis. To work in conjunction with chassis reverse drive system	1	
41.	6-Way Trailer Receptacle (Pin Type) Installed At Rear	1	
42.	Start/Stop/Throttle Module, 12 Volt System	1	
43.	Install secondary stowage system.	1	
<b><u>Finishing Details</u></b>			
44.	Altec Standard; Components mounted below frame rail shall be coated black by Altec. i.e. step bumpers, steps, frame extension, pintle hook mount, dock bumper mounts, D-rings, receiver tubes, accessory mounts, light brackets, under-ride protection, etc. Components mounted to under side of body shall be coated black by Altec. i.e. Wheel chock holders, mud flap brackets, pad carriers, boxes, lighting brackets, steps, and ladders.	1	
45.	Apply Non-Skid Coating to all walking surfaces	1	
46.	English Safety And Instructional Decals	1	
47.	Vehicle Height Placard - Installed In Cab	1	
48.	Placard, HVI-22 Hydraulic Oil	1	
49.	Dielectric test unit according to ANSI requirements.	1	

We Wish To Thank You For Giving Us The Pleasure  
And Opportunity of Serving You

UTILITY EQUIPMENT AND BODIES SINCE 1929

<u>Item</u>	<u>Description</u>	<u>Qty</u>	<u>Price</u>
50.	Stability test unit according to ANSI requirements.	1	
51.	Focus Factory Build	1	
52.	Delivery Of Completed Unit	1	
53.	Inbound Freight	1	
54.	AT40G FA Installation	1	
<u>Chassis</u>			
55.	Chassis	1	
56.	Customer Supplied Chassis	1	
57.	2017 Model Year	1	
58.	International 4300	1	
59.	4x2	1	
60.	84 Clear CA (Round To Next Whole Number)	1	
61.	Regular Cab	1	
62.	Chassis Cab	1	
63.	Set Back Axle	1	
64.	Other Engine Model	1	
65.	Allison 3000 RDS Automatic Transmission	1	
66.	GVWR 23,500 LBs	1	
67.	7,000 LBS Front GAWR	1	
68.	13,500 LBS Rear GAWR	1	
69.	Hydraulic Brakes	1	
70.	Park Brake In Rear Wheels	1	
71.	07BDA - International Exhaust (Right-Horizontal-Behind Cab-Horizontal)	1	
72.	12VZA - International PTO Throttle Wiring	1	
73.	International Heavy Duty Tail Light Wiring (08HAB)	1	
74.	International Transmission Dipstick Relocated to RH Side Of Transmission (13WGH)	1	
75.	No Prewire Chassis	1	

We Wish To Thank You For Giving Us The Pleasure  
And Opportunity of Serving You

UTILITY EQUIPMENT AND BODIES SINCE 1929



---

<u>Item</u>	<u>Description</u>	<u>Qty</u>	<u>Price</u>
76.	No Idle Engine Shut-Down Required	1	
77.	No California Emission Requirements	1	
78.	15SXJ - International 50 Gallon Fuel Tank Non-Polished (Under Cab Left Hand)	1	
79.	Battery Under Cab Left Hand	1	
80.	No Air Horn	1	
81.	AM/FM Radio	1	

**Additional Pricing**

82.	Standard Altec Warranty: One (1) year parts warranty, one (1) year labor warranty, ninety (90) days warranty for travel charges, limited lifetime structural warranty	1	
-----	---	---	--

---

Altec Industries, Inc.

BY

---

Kasey Ruth Tipton

**Notes:**

1 RECOMMENDED OPTIONS AND ACCESSORIES: These options are not included in the quote total price. Selected options will change the quote total. Any options added after initial order will be re-quoted.

OPTION -  
-5 Year Extended Warranty to include Labor, Material and Expense (No Travel)

2 Altec Standard Warranty:

One (1) year parts warranty.

One (1) year labor warranty.

Ninety (90) days warranty for travel charges.

Warranty on structural integrity of the following major components is to be warranted for so long as the initial purchaser owns the product: Booms, boom articulation links, hydraulic cylinder structures, outrigger

We Wish To Thank You For Giving Us The Pleasure  
And Opportunity of Serving You

UTILITY EQUIPMENT AND BODIES SINCE 1929

weldments, pedestals, subbases and turntables.

Altec is to supply a self-directed, computer based training (CBT) program. This program will provide basic instruction in the safe operation of this aerial device. This program will also include and explain ANSI and OSHA requirements related to the proper use and operation of this unit.

Altec offers its standard limited warranty with the Altec supplied components which make up the Altec Unit and its installation, but expressly disclaims any and all warranties, liabilities, and responsibilities, including any implied warranties of fitness for a particular purpose and merchantability, for any customer supplied parts

Altec designs and manufactures to applicable Federal Motor Vehicle Safety and DOT standards

- 3 Altec takes pride in offering solutions that provide a safer work environment for our customers. In an effort to focus on safety, we would encourage you to consider the following items:

- Outrigger pads (When Applicable)
- Fall Protection System
- Fire extinguisher/DOT kit
- Platform Liner (When Applicable)
- Altec Sentry Training
- Wheel Chocks

The aforementioned equipment can be offered in our new equipment quotations. If you find that any of these items have not been listed as priced options in the body of your quotation and are required by your company, we would encourage you to contact your Altec Account Manager and have an updated quotation developed for you. These options must be listed as individual options in the body of the quotation for them to be supplied by Altec.

- 4 Unless otherwise noted, all measurements used in this quote are based on a 40 inch (1016mm) chassis frame height and standard cab height for standard configurations.

- 5 F.O.B. - Customer Site

- 6 Changes made to this order may affect whether or not this vehicle is subject to F.E.T. A review will be made at the time of invoicing and any applicable F.E.T. will be added to the invoice amount.

- 7 Price does not reflect any local, state or Federal Excise Taxes (F.E.T). The quote also does not reflect any local title or licensing fees. All appropriate taxes will be added to the final price in accordance with regulations in effect at time of invoicing.

- 8 Interest charge of 1/2% per month to be added for late payment.

- 9 Delivery: 270-300 days after receipt of order PROVIDING:
- A. Order is received within 14 days from the date of the quote. If initial timeframe expires, please contact your Altec representative for an updated delivery commitment.
  - B. Chassis is received a minimum of sixty (60) days before scheduled delivery.
  - C. Customer approval drawings are returned by requested date.
  - D. Customer supplied accessories are received by date necessary for compliance with scheduled delivery.
  - E. Customer expectations are accurately captured prior to releasing the order. Unexpected additions or changes made at a customer inspection will delay the delivery of the vehicle.

Altec reserves the right to change suppliers in order to meet customer delivery requirements, unless specifically identified, by the customer, during the quote and or ordering process.

- 10 Trade-in offer is contingent upon equipment being maintained to DOT (Department of Transportation) operating and safety standards. This will include, but not limited to tires, lights, brakes, glass, etc. If a trade-in is not maintained to DOT standards, additional transportation expenses will apply and could be invoiced separately.
- All equipment, i.e., jibs, winches, pintle hooks, trailer connectors, etc., are to remain with the vehicle unless otherwise agreed upon in writing by both parties. Altec Industries reserves the right to re-negotiate its trade-in offer if these conditions are not met.
- Customer may exercise the option to rescind this agreement in writing within sixty (60) days after receipt of purchase order. After that time Altec Industries will expect receipt of trade-in vehicle upon delivery of new equipment as part of the terms of the purchase order.
- Titles for trade-in equipment should be given to the appropriate Altec Sales associate or forwarded to Altec Nueco at address 1730 Vanderbilt Road, Birmingham, AL 35234.
- 11 This quotation is valid until AUG 04, 2016. After this date, please contact Altec Industries, Inc. for a possible extension.
- 12 After the initial warranty period, Altec Industries, Inc. offers mobile service units, in-shop service and same day parts shipments on most parts from service locations nationwide at an additional competitive labor and parts rate. Call 877-GO-ALTEC for all of your Parts and Service needs.
- 13 Please email Altec Capital at [finance@altec.com](mailto:finance@altec.com) or call 888-408-8148 for a lease quote today.
- 14 Please direct all questions to Jenny Carlson at (270) 360-0600

## ISB6.7 Base Warranty.

Cummins 6-cylinder ISB6.7 engine has coverage similar to that of the ISL9, except there is no mileage restriction. The ISB6.7 warranty is good for 2 years with unlimited mileage.

### 2-Year/Unlimited-Mileage Coverage

- 100 percent parts and labor on warrantable failures\*
- Travel or towing when an engine is disabled by a warrantable failure (from date of delivery through the first year)
- Consumables not reusable due to covered failure
- No deductible
- Includes aftertreatment



\*Warrantable failures are those due to defects in Cummins material or factory workmanship.

### Extended Coverage Means Added Security.

A Cummins Protection Plan is the most important travel insurance you can buy. Not only will it protect your business from unexpected expenses, but it will also ensure that you'll always get quality Cummins parts and professional Cummins service. There are two plans to choose from for ISL9 and ISB6.7 engines.

### Protection Plan 1

Security is knowing that you are protected by comprehensive protection, with options ranging from 3 to 5 years and 100,000 to 300,000 miles (160,934-482,803 km).

- Internal components and major engine systems including the turbocharger, water pump and fuel injectors and, new for 2013, the air compressor, fuel pump and select engine sensors
- Registered parts and labor on covered failures

### Protection Plan 2

Cummins Internal Protection Plan 2 covers you against major repair costs down the road, with registered parts and labor on major components and your choice of long-term options from 3 to 7 years and 100,000 to 300,000 miles (160,934-482,803 km).

- Internal components and major engine systems
- Registered parts and labor on covered failures

### Aftertreatment Extended Coverage\*

Extended coverage is also available for your Cummins Aftertreatment System. Options range from 3 to 5 years and 100,000 to 300,000 miles (160,934-482,803 km).

The coverage includes Cummins-supplied aftertreatment components, including:

- Diesel Oxidation Catalyst (DOC), Diesel Particulate Filter (DPF) and Selective Catalytic Reduction (SCR) assemblies
- Diesel Exhaust Fluid (DEF) dosing system
- Aftertreatment controls
- Ammonia sensor

\*Protection Plan 1 EPA 2013 of equal duration is required prior to the purchase of the Aftertreatment Extended Coverage.

## 2013 ISL9 And ISB6.7 Extended Coverage Terms\*

SCR Assembly	<b>Aftertreatment Extended Coverage**</b>	
Decomposition Reactor		
Mid-Bed Ammonia Sensor		
DPF Assembly		
Fuel Pump		
Air Compressor		
Select Engine Sensors		
Water Pump		
Turbo		
Fuel Injectors		
EGR Cooler, EGR Valve, EGR Mixer	<b>Protection Plan 1</b>	<b>Options are available up to 5 years/ 300,000 miles (482,803 km)</b>
Cylinder Head Assembly		
ECM		
Pistons, Rings and Liners		
Lube Oil Cooler Assembly		
Cylinder Block Assembly		
Crankshaft Assemblies		
Front Gear Cover		
Oil Pan		
Connecting Rod Assembly		
Lube Pump Assembly	<b>Protection Plan 2</b>	<b>Options are available up to 7 years/ 300,000 miles (482,803 km)</b>
Camshaft Assembly and Bushings		
Brake Housing, Bushings, Rocker Levers, Roller Pin, Roller, Crosshead Pin, Crosshead, Including Mounting Hardware and Gaskets		
Engine Cylinder Block Casting		
Engine Main Bearing Bolts		
Engine Cylinder Head Casting		
Engine Cylinder Head Capscrews		
Engine Crankshaft Forging		
Engine Camshaft Forging		
Cam Follower Housing		
Cam Follower Assemblies		
Engine Connecting Rods and Caps		
Engine Connecting Rod Bolts		
Intake Manifold Castings		
Rocker Lever Housings		
Rocker Lever Assembly		
Gear Train Gears		

\*Terms and conditions are subject to change.

\*\*Protection Plan 1 EPA 2013 of equal duration is required prior to the purchase of the Aftertreatment Extended Coverage.



# Every™ Coverage.

North American Truck Coverages  
For 2013 ISL9 And ISB6.7 Engines.

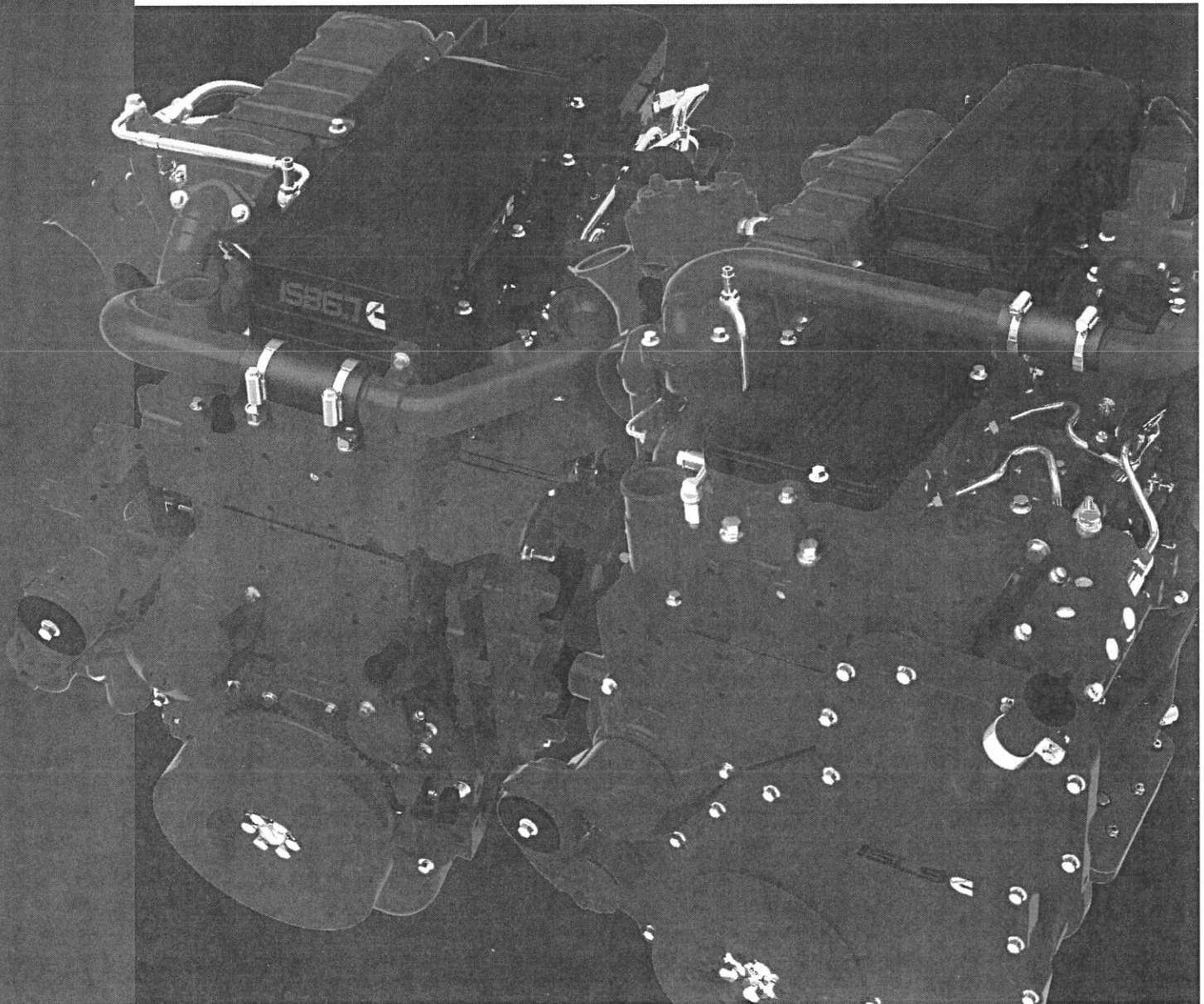



OPTIONAL SERVICE CONTRACTS

CTS-2102C

POLICY ISSUED BY: DEALER NAME	
CITY	DEALER ACCOUNT NUMBER
STATE/PROVINCE	POSTAL ZONE
YEAR	MODEL
VEHICLE IDENTIFICATION NUMBER (FULL 17 DIGITS)	
ENGINE SERIAL NUMBER	ODOMETER READING AT DELIVERY
DATE OF DELIVERY TO USER (DTU)	
ABOVE INFORMATION MUST AGREE WITH DELIVERY TO USER (DTU) FORM AND DELIVERY INFORMATION ESTABLISHED BY RETAIL SALE	
CONTRACT HOLDER'S NAME	
STREET	
CITY	
STATE/PROVINCE	POSTAL ZONE
COVERAGE	SERVICE CONTRACT NUMBER
EXTENDED VEHICLE COVERAGE	TIME MONTHS
	DISTANCE - MI./KM (000)
CONTRACT TERMS	
CUSTOMER: I HAVE REVIEWED THE OWNER / OPERATOR'S MANUAL FOR THIS VEHICLE AND READ THIS WARRANTY AGREEMENT AND:	
(1) I UNDERSTAND THE OPERATION OF THIS VEHICLE, (2) I UNDERSTAND AND ACCEPT THE TERMS OF THIS WARRANTY AGREEMENT, AND (3) I ACKNOWLEDGE RECEIPT OF A COPY OF THIS WARRANTY AGREEMENT.	
CUSTOMER SIGNATURE	DATE
DEALER: (1) YOU MUST REVIEW THE STANDARD WARRANTY AND THIS EXTENDED WARRANTY SERVICE POLICY ALONG WITH THE OWNER / OPERATOR'S MANUAL WITH THE CUSTOMER AT THE TIME OF SALE, (2) FOR U.S. AND CANADIAN SALES, SUBMIT A COPY OF THIS CONTRACT TO: <a href="mailto:SERVICECONTRACTS@NAVISTAR.COM">SERVICECONTRACTS@NAVISTAR.COM</a>	
DEALER SIGNATURE	DATE
DEALER EMAIL	PHONE #

DEALER: SELECT/WRITE IN APPLICABLE SERVICE CONTRACT NUMBER, CONTRACT PARAMETERS, & MILEAGE/KM ABOVE WHERE REQUIRED FROM PLH-284/PL-284/PLM-282 PRICE PAGES.  
 ORIGINAL - CUSTOMER COPY. PHOTOCOPY COMPLETED ENROLLMENT FORM & EMAIL TO [SERVICECONTRACTS@NAVISTAR.COM](mailto:SERVICECONTRACTS@NAVISTAR.COM) FOR WARRANTY REGISTRATION.  
 A 5% FEE OVER RETAIL PRICE WILL BE CHARGED FOR WARRANTIES PURCHASED BETWEEN 6-12 MONTHS PAST WARRANTY START DATE.

EXTENDED VEHICLE COVERAGE

The Vehicle Service Coverage option(s) provides coverage to your vehicle for time or distance traveled from new vehicle delivery date, whichever expiration occurs first.

During the period selected, Navistar, Inc., will repair or replace any part of this vehicle covered component(s) which proves defective in material and/or workmanship in normal use, with new or ReNEWed parts. Exceptions are listed herein under *What is Not Covered*.

Not applicable for rear axle weight ratings over 52,000 pounds

FRAME:

Bumper System: bracket or mounting, bumper, bumper frame, bumper stop cable, hinge, latch assembly.

Frames: outrigger, bus platform mounting, tire carrier, cross-member, engine cross-member, frame side rail, reinforcements and gussets.

FRONT AXLE:

Driving Front Axle: steering arm, fitting (zerk), internal gears, king pin and bushings, king pin seal, pinion oil seal

Non-Driving Front Axle: steering arm, fitting (zerk), front axle I-beam, king pin and bushings, steering knuckle, king pin seal.

SUSPENSION:

Springs/Suspension: air bag assembly, rubber biscuit (shear or compression), center bolt, spring bracket assembly, shock absorber mounting bracket, control (air suspension only), rear suspension cross-member, equalizer/rocker arm and bushing, spring leaf assembly, pins and bushing shackles, axle stop, sway bar assembly, torque arm and bushing assembly, trailing arm and bushing assembly, walking beam and bushing assembly.

Suspension Controls: suspension air control manifold assembly, ECM suspension

BRAKES:

Wheel Brake Components: automatic adjuster assembly, slack adjuster, backing plate/anchor/dust shield, brake chamber bracket, caliper, chamber, chamber diaphragm, wheel brake actuating linkage/cam/camshaft, brake shoe return spring.

ABS Components: electronic control unit (ECU), cab harness, relay/magnetic switch, wheel sender, steering angle sensor, stability control sensor, modulator valve.

Air Brake System Components: accumulators, master cylinder, air dryer end cover/unloader valve, air governor and mounting, cab harness, front end harness, PDM distribution harness, parking brake lever/pedal, brake actuating linkage/pedal/spring, pulley, relay/magnetic switch, solenoid valves, spring applied air release canister (SAAR), air or vacuum tank, foot control or pedal valve, front wheel limiting and mounting valve, hand control valve, quick release valve, relay valve, spring brake control valve, tractor protection valve.

**Hydraulic Brake System Components:** accumulators, drive line brake assembly, parking brake cable/linkage, master cylinder, self actuating hydraulic release cylinder (SAHR), air dryer end cover/unloader valve, cab harness, front end harness, PDM distribution harness, hydraulic power brake unit (HPB), parking brake lever/pedal, brake actuating linkage/pedal/spring, monitor module, back-up motor, power assist unit, pulley, back-up pump (less motor), pumps, relay/magnetic switch, reservoir, solenoid valves, back-up motor switch, flow switch, fluid level switch, pressure differential switch, air or vacuum tank, foot control or pedal valve, hand control valve, spring brake control valve.

**STERING SYSTEM:**

**Steering:** pitman arm, steering gear bracket/mounting, steering column assembly and mounting, oil cooler assembly, steering shaft coupling/u-joint, cylinder assembly and valves, power steering pump mounting, gasket, steering gear assembly, drag link, pulley, pump assembly, reservoir assembly, control valve, telescoping steering wheel mechanism, tilt steering wheel mechanism, steering wheel.

**PROPSHAFT:**

**Propeller Shafts:** slip joint boot/clamp, universal joint, shaft, yoke/spline.

**Center Bearing Assembly:** bearing, bearing mounting.

**EXHAUST:**

**Muffler:** basic assembly, mounting bracket/support, guard (other than muffler guard)

**Pipes:** mounting bracket/support, stack cap, guard/heat shield, tail pipe/stack, exhaust pipe and flange, crossover pipe, flex pipe, exhaust gas cooler tail pipe.

**ELECTRICAL:**

**Generating System:** alternator assembly, cab harness, PDM distribution harness, pulley, voltage regulator, relay/magnetic switch.

**Electric Door Locks:** door lock actuator, door harness, driver door switch pod, passenger door switch pod, other door switch pod.

**Instruments, Electrically Operated:** pyrometer amplifier, bezel/cover plate, speedometer/tachometer circuit housing, ammeter gauge, electrical coolant temperature gauge, engine oil temperature gauge, fuel level gauge, electrical oil pressure gauge, pyrometer gauge, rear axle oil temperature gauge, electrical speedometer gauge, electrical tachometer gauge, transmission oil temperature gauge, voltmeter gauge, cab harness, PDM distribution harness, hour meter, ammeter module, pyrometer module, multiplex signal module (MSM), odometer, programming, air pressure sender, fuel level sender, pyrometer sender, rear axle oil temperature sender, transmission oil temperature sender,

speedometer/tachometer dip switch (reprogramming only), tachometer/trip recorder (electrically driven).

**Remote Power Module:** switch pack actuator, cab harness, PDM distribution harness, (RPM) module, switch pack (base).

**Remote Engine Speed Control:** remote engine speed control module, PDM distribution harness.

**Body Electrical System Controller Components:** ESC Controller, programming.

**Cranking System:** cab harness, PDM distribution harness, starter motor, relay/magnetic switch, starter motor solenoid, clutch switch, key/ignition switch, neutral start switch, push button starter switch.

**Battery Run Down Protection:** jumper cable batteries, clean power cable (battery to transmission), clean power cable (battery to cab), clean power cable (battery to engine), module monitor, battery run down protection monitor, solenoid, low oil pressure switch.

**Lighting Systems:** switch pack actuator, back-up alarm, automatic headlight sensor, flasher, cab harness, front end harness, PDM distribution harness, lamp assembly, mounting, relay/magnetic switch, switch pack (base), back-up light switch, daytime running light switch (DRL), dimmer switch, headlight switch, door jam mounted interior light switch, lamp mounted interior light switch, panel mounted interior light switch, marker/interrupt switch, stoplight-air switch, stoplight-hydraulic switch, turn signal switch

**Trailer Lighting:** cab harness, relay/magnetic switch.

**Warning Lights and Signals:** high water temperature/low oil pressure alarm, hydraulic brake warning beeper, low air pressure beeper, cab harness, PDM distribution harness, lamp assembly, coolant probe module, coolant level probe, relay/magnetic switch, front axle engaged switch, high water temperature switch, low air pressure switch, low coolant level switch, low oil pressure switch, parking brake switch, power divider engaged switch.

**Horn (Electric):** horn contact ring/button, cab harness, coiled ribbon harness (clock spring), front end harness, PDM distribution harness, horn assembly, mounting, relay/magnetic switch.

**Window (Electric):** cab harness, window regulator and motor assembly, relay/magnetic switch.

**Two Speed Axle/Power Divider Lock (Electric):** switch pack actuator, circuit board (instrument housing), cab harness, PDM distribution harness, relay/magnetic switch, air solenoid, switch pack (base).

**Accident Avoidance Radar System:** antenna and lead-in, central processing unit (CPU), side sensor display, cab harness, front end harness, side sensor harness, turn sensor assembly magnet, driver display unit monitor, side sensor, turn assembly sensor.

**Lift Gate Accommodation:** battery run down protection monitor, relay/magnetic switch.

**Telematics:** cab harness, PDM distribution harness, SOS switch, telematics control module (TCM).

**Vehicle System Controller Components-Prognostics:** tire pressure monitor antenna, brake stroke chamber w/sensor, vehicle information display, fuel filter restriction globe w/sensor, vehicle sensor module, tire pressure monitor module/controller, programming, brake pad wear sensor, tire pressure monitor wheel module.



**Steering Wheel Switches:** air horn switch, cruise on/off switch, cruise set/reset switch, engine brake on/off switch, headlight interrupt switch, marker interrupt switch, radio switch, transmission mode switch, transmission shift switch.

**Miscellaneous (Electrical):** clock, electronic compass, cab harness, driver display unit monitor, circuit breaker/relay/fuse panel mounting, circuit breaker/relay/fuse panel, pneumatic accessory solenoid base, pneumatic accessory solenoid unit, electronic thermometer.

**COOLING:**

**Hybrid/Electric Drive Cooling:** coolant recovery bottle and hose, core, fan module, motor/pump. (Applicable with DuraStar, WorkStar)

**Radiator:** coolant recovery bottle and hose, shroud clamp, in tank oil cooler, radiator core, sight glass, radiator hose/pipe, radiator mounting, shroud, shroud mounting bracket, engine mounted shroud, surge tank and mounting, radiator tank and neck.

**Shutters:** actuating cylinder assembly, cab harness, PDM distribution harness, relay/magnetic switch, control rod assembly, shutter assembly, shutterstat, solenoid, temperature switch.

**Charge Air Cooler:** chassis mounted charge air cooler, charge air cooler pipe.

**Hydraulically Driven Cooling Fan:** fan blade assembly, electronic fan controller, hydraulically fluid reservoir, motor, oil cooler (oil-to-air), pump assembly, solenoid valves.

**INSTRUMENTS:**

**Oil Pressure Gauge:** head assembly.

**Temperature Gauge:** head assembly

**Air Pressure Gauge:** head assembly

**Air Restriction Gauge:** head assembly

**CLUTCH:**

**Control components:** release bearing and sleeve assembly, external linkage, clutch release fork and cross shaft, relay lever assembly, pedal, self-adjusting mechanism, master cylinder, slave cylinder.

**Clutch assembly components:** intermediate plate (2-plate clutches only), pressure plate assembly.

**ENGINE:**

**Electronic Engine Components:** SART module, accelerator pedal assembly.

**Engine Fans:** fan blade assembly, fan clutch control, on/off fan drive, viscous fan drive, fan pulley, relay/magnetic switch, solenoid, temperature switch.

**Engine Mounting:** front mount/bolt, rear mount/bolt.

**Accessory Drive Systems:** air compressor mounting bracket, alternator mounting bracket, refrigerant compressor mounting bracket, \*accessory drive coupling, \*power steering pump driver gear, \*pulley/idler/bearing, \*belt tensioner.

**TRANSMISSION:**

**Basic Components:** transfer case, companion flange, bell housing, bearing retainer

**Lubrication System:** oil cooler (oil-to-air), oil cooler line

**Electronic Controls:** resistor block, cab harness, PDM distribution harness, brake switch, on/off switch.

**Controls:** remote shift control linkage/cable

**Mounting:** mounting

**Cover Assembly:** detent poppet ball and spring

**REAR AXLE:**

**Basic Axle Components:** carrier, companion flange/yoke, axle housing.

**Axle Carrier Components:** internal bearings, limited slip differential, gears, bushings and cross differential, oil pump, wheelend gearboxes.

**Axle Gear Set:** ring gear bolt, helical gears, planetary gears, ring and pinion gears.

**Shafts and Seals:** helical drive gear shaft.

**Controls:** sliding clutch, air shift control, air shift cylinder, shift fork, air shift motor.

**Power Divider Components:** power divider bearing/retainer, power divider differential case, power divider gears/bushings and cross, power divider housing/gasket, power divider shaft and seals, power lock out switch.

**Axle, Steering, Wheel Ends:** steering arm, axle housing, knuckle king pin, steerable knuckle, stud.

**Suspension and Brakes:** slack adjuster, air bag assembly, chamber, control (air suspension control), hanger and crossmember assembly, lift spring, air or vacuum tank.

**Electrical:** relay/magnetic switch, cab harness, air solenoid.

**Non-Driving Rear Axle:** axle tube.

**FUEL SYSTEM:**

**Air Inlet System:** air intake grille, air inlet box/water separator, stack mounting bracket, air inlet cap/scoop, air inlet temperature control system, air restriction indicator, air inlet pipe.

**Air Cleaner:** filter body gasket, mounting bracket and bolts, \*air cleaner snow valve motor, \*air cleaner snow valve switch

**Fuel Tanks:** mounting bracket and bolts, filler neck/cap and gasket, crash guard, tank body, electric transfer pump (tank to tank), fuel outlet tube, fuel tank valve/control, air vent, chassis skirt, finish (metal), cab harness (wires, connectors, and terminals).

**Chassis Mounted Fuel/Water Separator:** water in fuel sensor, pre-heater element, drain valve, check valve, cab harness (wires/connectors/term), vent cap, primer pump, collar, body

**CAB:**

**Front End Sheet Metal:** air intake baffle/water separation baffle, hood cable, lift cylinder, hood/engine access door, grille assembly, hood handle, front hood mounting hinge/bracket, hood/engine access door hatch hinge, hood, hood guides, engine compartment insulation, doghouse panel/engine latch, engine access door latch, hood latch, splash panel, hood reinforcement, rivet/fastener, sound shield, hood stop, hood assist torsion bar, hood trim, weld.

**Cab/Platform Structure:** cowl/firewall/SC or FC platform, air deflector mounting, doghouse panel/engine cover, panel/skin, back panel, engine surround panel, floor panel, halo panel, instrument panel, rocker panel, rivet/fastener, roof, sill, structure, ventilator, weld.

**Sleeper:** bunk occupant restraint strap, cabinets, door, hinge, insulation, latch and exterior handle, interior mirror, mounting, panel/skin, rivet/fastener, shore power connection, structure, sleeper bunk suspension, bunk trim, interior trim, under bunk lift assist shock, ventilator, weld, sleeper window.

**Doors, Assemblies, and Controls:** glass run channel, lift cylinder, door, hinge, latch and exterior handle, passenger door map pocket, window regulator and handle, door control/cable, rivet/fastener, door stop assembly, vent window and seal, weld.

**Cab Mounting:** cab tilt hinge mechanism, cab tilt lock mechanism, cab mounting crossmember, lift cylinder, latch assembly, mounting, front cab mounting, intermediate body mounting, cab spring/shock absorber and mounting, sub-frame, control valve.

**Cab Interior Appointments:** arm rest, console, grab handle, cup holder, insulation, manifest box/door pouch, interior mirror, door trim-driver side panel, door trim-passenger side panel, rear trim panel, interior trim, ventilator, sun visor.

**Cab Exterior Appointments:** head or tail lamp bezel, mirror bracket, sun shade mounting bracket, cowl tray, radiator access door assembly, grab handle, cab harness, mirror heater, exterior mirror (basic), spot mirror, mirror motor, relay/magnetic switch (electric mirror), sun shade, cab step, electric mirror switch.

**WHEELS:** disc wheel, hub (disc wheel), rim (demountable), spoke wheel.

#### SCR AFTERTREATMENT:

Pump to tank supply/suction hose, pump to tank return hose, pump to doser/injector hose, filler tank cap, DEF tank sensor assembly (includes DEF level, temp, and quality sensors), tank heater, tee to doser hose, doser to tee hose, DEF tank bracket/strap, diesel exhaust fluid tank, tank pickup, coolant flow valve tank DEF, heated line wiring, head unit wiring, supply module cover, ACM bracket, supply module wiring, supply module pump bracket, ACM wiring, (sensor) wiring, PDM module.

#### ACCESSORIES:

**Air Conditioning:** accumulator/dryer, motor/door-air distribution actuator, motor/door-blend air actuator, motor/door-fresh air actuator, air conditioning oring, resistor block, compressor clutch, compressor/reciprocating compressor/rotary, condenser, air conditioner/heater/defroster ducting, evaporator, fitting, hose/pipe, cab harness, under cab to rear HVAC hose, blower speed LPM module, diagnostic-APADS module, HVAC control module, sleeper blower motor, motor, mounting/housing (main case), relay/magnetic switch, high side schrader valve, low side schrader valve, refrigerant pressure sensor, switch, on/off bunk switch, bunk-temperature control switch, temperature switch, high pressure switch, low pressure switch, thermostatic switch, freeze sensor, thermistor-inlet, thermistor-outlet, orifice tube, expansion valve, expansion rear valve, blower wheel.

**Heating System:** motor/door-air distribution actuator, motor/door-blend air actuator, motor/door-fresh air actuator, resistor block, core (heater), air conditioner/heater/defroster ducting, defroster fan, cab harness, under cab to rear HVAC hose, blower speed LPM module, diagnostic-APADS module, HVAC control module, sleeper blower motor, motor, mounting/housing (main case), relay/magnetic switch, switch, bunk-on/off switch, bunk-temperature control switch, radiator fan/shutter override switch, expansion rear valve, blower wheel.

**Air Horns:** cab harness, horn assembly, pneumatic solenoid, air horn switches, control valve.

**Windshield Wiper System:** mounting bracket, cab harness, wiper linkage, motor, wiper-air or vacuum motor, relay/magnetic switch, switch, intermittent switch, control valve.

**Windshield Washer System:** cab harness, front end harness, hose/pipe, fitting, switch, pump, reservoir, low fluid level switch.

**Air Starter System:** cranking motor drive assembly, motor, tank assembly and mounting, check valve, control valve.

**Radio-Entertainment and C.B. (only applicable if factory installed):** amplifier, C.B.-basic assembly, CD changer, radio control (sleeper box), DVD entertainment system, cab harness, radio-basic assembly, satellite module-basic assembly, speaker, subwoofer.

**Cruise Control:** cab harness, coiled ribbon harness (clock spring), vehicle personality module (VPM), relay/magnetic switch, switch, clutch switch, set/restore switch.

**Seats:** seat adjuster assembly, electric seat air compressor, air bag, seat belt, air seat control, seat frame, arm rest, seat belt retractor, seat shock.

**Engine Attachments/Floscan:** either start assembly, cab harness, engine heater assembly, engine meter assembly, relay/magnetic switch, engine heater socket, switch (either start), temperature switch (either start).

**Chassis Attachments:** air solenoid pack, air solenoid, auxiliary air tank.

**Miscellaneous Attachments:** air deflector-roof mounted, air deflector-side mounted and brackets, back-up camera.

**Fifth Wheel:** fifth wheel control, fifth wheel lock cylinder, fifth wheel plate

**OBTAINING SERVICE:** To obtain service under this Service Contract, return this vehicle to any Navistar Truck Dealer authorized to service this model vehicle and engine.

#### WHAT IS NOT COVERED Components / Items:

- Correction of loose fasteners, squeaks, rattles and unusual noises.

- Adjustments (e.g., headlights, brake/clutch adjustments, steering system adjustments, coolant levels).
- Items warranted by their respective manufacturers (e.g., non-Navistar brand engines, tires & tubes, Allison Transmissions, Agility Fuel System, clutch, batteries, radios, lubricants, etc).
- Any part that is not a Navistar part number.
- Unauthorized parts other than Navistar service parts or ReNEWed® parts.
- Bodies, equipment and accessories installed by other than authorized Navistar employees at Navistar manufacturing plants.
- Front and rear axle alignment.
- Engine, Engine Electronics, Injectors, Turbocharger.
- Hybrid Electric Components (except Hybrid/Electric Drive Cooling).

**Repairs:**

- Maintenance-related items/ repairs or those as a result of normal wear and tear, including tune-ups, brake/clutch lining, clutch brake, windshield wiper blades, windshield wiper nozzles, gaskets, belts, seals, tire balancing, lubrication, batteries and other similar procedures/parts required to keep vehicle in good working condition. These services include, but are not limited to: oil changes, oil filters, air filters, fuel filters, cleaning/polishing, engine tune-up, adding oils, tightening of air intake and coolant clamps, ash tray, cigarette lighter element, fire extinguishers, fluorescent ballast and tubes, fuses, gladhand and gladhand rubbers, trailer hoses, hose tenders, trailer electrical cables, light bulbs, mattress, mud flaps, mud flap mounting bracket.
- Repairs to any part of the vehicle subjected to misuse, negligence, improper maintenance, improper operation, or which is the result of an accident.
- Fades, runs, mismatch or damage to paint, trim items, upholstery, chrome, polished surfaces, etc., resulting from environmental causes, improper polishes, cleaners or washing solutions, or chemical and industrial fallout.
- No coverage will be granted if Power Train, Propshaft and Suspension sales guidelines (specifications) are not strictly adhered to by all owners and operators of this vehicle.
- Accidents, acts of nature or other events beyond control of Navistar.
- Any single repair requiring less than \$40.00 parts and labor to complete.
- Paint, rust, corrosion, cosmetic issues, bright work
- Failure to maintain correct maintenance schedule.
- Failures or damage resulting from abuse or neglect as determined by Navistar, which includes, but is not limited to: operation without adequate coolants or lubricants; over speeding; lack of maintenance of lubricating, cooling or intake systems; improper storage, starting, warm-up, run-in or shutdown practices.

**Other:**

- Vehicles sold and/or operated outside the United States or Canada.
- Vehicles/components which have had unauthorized alterations or modifications.
- Vehicles on which the odometer reading has been altered.
- Incidental, special, indirect or consequential costs or expenses which the owner may incur as a result of a malfunction or failure covered by this warranty, such as vehicle damage, communication expenses, meals, lodging, overtime, loss of use of engine or vehicle ("downtime"), loss of time, inconvenience, cargo loss or damage, and other similar costs and expenses.
- Replacement of defective parts, which were, not authorized Navistar equipment when first installed.
- Towing, unless additionally purchased.

**\*Components EXCLUDED but not limited to if unit has a NON-Navistar**

**Brand Engine:**

**Accessory Drive Systems:**

- Fuel pump drive cam, \*accessory drive coupling, \*power steering pump driver gear, \*pulley/idler/bearing, \*belt tensioner.

**Air Cleaner:**

- \*Air cleaner snow valve motor, \*air cleaner snow valve switch

**NOTE TO SERVICING LOCATION:**

Should there be questions regarding this coverage, call the Warranty Claim Center for clarification. For this purpose, the following phone numbers are provided to be used weekdays during normal business hours in the 48 contiguous states, Hawaii and Canada, call 800-336-4500.

**DISCLAIMER:**

NO WARRANTIES ARE GIVEN BEYOND THOSE DESCRIBED HEREIN. THIS WARRANTY IS IN LIEU OF ALL OTHER WARRANTIES, EXPRESSED OR IMPLIED AND IS THE SOLE AND EXCLUSIVE WARRANTY MADE BY THE COMPANY HEREUNDER. THE COMPANY SPECIFICALLY DISCLAIMS ALL IMPLIED AND EXPRESS WARRANTIES, INCLUDING WARRANTIES OF MERCHANTABILITY AND FITNESS FOR A PARTICULAR PURPOSE, ALL OTHER REPRESENTATIONS TO THE USER/PURCHASER, AND ALL OTHER OBLIGATIONS OR LIABILITIES. THE COMPANY FURTHER EXCLUDES LIABILITY FOR INCIDENTAL, SPECIAL, INDIRECT, PUNITIVE AND CONSEQUENTIAL DAMAGES, ON THE PART OF THE COMPANY OR SELLER. No person is authorized to give any other warranties or to assume any liabilities on the company's behalf unless made or assumed in writing by the Company, and no other person is

authorized to give any warranties or to assume any liabilities on the seller's behalf unless made or assumed in writing by the seller.

**Remedies Under State or Provincial Law:** Some States and Provinces do not allow the exclusion or limitation of incidental or consequential damages, so the above limitation or exclusion may not apply to the owner. This warranty gives the owner specific legal rights, and he may also have other legal rights which may vary by state or province.

Navistar, Inc., except in Canada where it is Navistar Canada, Inc.