

Grant Agreement Documentation Order: Property Improvement Program (PIP)

- | | |
|---|----------------|
| 1. Reso | DRAFT |
| 2. Signed Agreement | DRAFT |
| 3. W-9 | Page 02 |
| 4. Grant Application – Back Up I | Page 03 |
| 5. Letter of Intent – Back Up I | Page 04 |
| 6. Property Insurance – Back Up I | Page 05 |
| 7. Ownership Information – Back Up I | Page 08 |
| 8. Current Photos – Back Up I | Page 17 |
| 9. Letter of Authorization – Exhibit A | Page 20 |
| 10. Bib Summary Form – Exhibit B | Page 22 |
| 11. Selected Contractor(s) Quotes, Licenses and Insurance – Exhibit B | Page 24 |
| 12. Renderings – Exhibit B | |
| 13. Non-Selected Contractor(s) Quotes – Back Up II | Page 69 |

Oxford Towers W-9



Property Improvement Program (PIP) Application

Name: Mike Rea

Name of Business/Property to be Renovated: Oxford Towers

Address: 1501 S. Deegan Drive, Hollywood, FL 33019

Telephone Number: 786-410-6727

Are you the Property Owner or Business Owner? Board President

Type of Improvement(s) Planned:

Incentive Amount: \$ _____

Total Cost of Project: \$ _____

I hereby submit the attached plans, specification and color samples for the proposed project and understand that these must be approved by the Hollywood, Florida Community Redevelopment Agency ("CRA"). No work shall begin until I have received written approval from the CRA. I further understand that unless otherwise approved by the CRA Board, funding will not be paid until the project is complete.

Michael A. Rea
Signature of Applicant

7/10/24
Date

Michael A. Rea
Print Name



OXFORD TOWERS, INC
c/o American Management Enterprise Corp.
1501 South Ocean Dr.
Hollywood, FL 33019

To whom it may concern,

We are the Board of Directors of the Oxford Towers Condominium ("Oxford") located at 1501 S Ocean Dr in Hollywood, Florida. Our building is a prominent structure situated directly on Ocean Drive, here in Hollywood Beach.

We have observed with great appreciation the accomplishments of the Hollywood CRA to revitalize and enhance the streets and the entire beach barrier island. As fellow residents, we want to very much be a part of this exciting effort.

Oxford Towers is 54 years old and this year, we are initiating a major renovation project with an investment of approximately \$4.5 million dollars. The scope of work includes restoration of concrete on the entire exterior of the building, rebuilding all balconies, installing new balcony railings, replacing all our fire doors, installing all new exterior lighting for the balconies, new asphalt and well creating an enhanced contemporary treatment of the first floor of the building. In addition, all old hurricane shutters on balconies will be removed, new windows and sliding doors are being installed where needed, and the entire building will be painted with fresh new colors.

The final phase in the renovation of Oxford Towers is to address the footprint of the building along the South Ocean Dr front entrance. Our team has recommended that the Board hire a landscape architect to create a new streetscape for these areas. We are also considering installing new up-lighting in the plantings area to enhance the building

In March of this year, we started speaking to Mr. Chris Croscuitto from your office to learn more about the Property Improve Program (PIP). Mr. Croscuitto graciously explained the goals and requirements for the program. Since then, we have taken a closer look at our building and have determined that undertaking these additional improvements would enhance the building and would also complement the CRA's efforts. Hence, our Board has authorized the submission of the attached application for the PIP.

Currently, we just initialized the process by selecting the contractors to help us develop our new vision for Oxford Towers. As required by the PIP, we have obtained bids for each item in our proposed scope of work along with pictures of existing conditions. We look forward to working with CRA staff to make this happen.

Thank you in advance for your anticipated assistance and cooperation in this matter.

Michael Rea, President

Signature

Date

9/18/24



CERTIFICATE OF LIABILITY INSURANCE

2/6/2025

DATE (MM/DD/YYYY)
9/13/2024

THIS CERTIFICATE IS ISSUED AS A MATTER OF INFORMATION ONLY AND CONFERS NO RIGHTS UPON THE CERTIFICATE HOLDER. THIS CERTIFICATE DOES NOT AFFIRMATIVELY OR NEGATIVELY AMEND, EXTEND OR ALTER THE COVERAGE AFFORDED BY THE POLICIES BELOW. THIS CERTIFICATE OF INSURANCE DOES NOT CONSTITUTE A CONTRACT BETWEEN THE ISSUING INSURER(S), AUTHORIZED REPRESENTATIVE OR PRODUCER, AND THE CERTIFICATE HOLDER.

IMPORTANT: If the certificate holder is an ADDITIONAL INSURED, the policy(ies) must have ADDITIONAL INSURED provisions or be endorsed. If SUBROGATION IS WAIVED, subject to the terms and conditions of the policy, certain policies may require an endorsement. A statement on this certificate does not confer rights to the certificate holder in lieu of such endorsement(s).

PRODUCER Lockton Companies, LLC 3280 Peachtree Road NE, Suite #1000 Atlanta GA 30305 (404) 460-3600	CONTACT NAME:	
	PHONE (A/C, No, Ext):	FAX (A/C, No):
	E-MAIL ADDRESS:	
INSURER(S) AFFORDING COVERAGE		NAIC #
INSURER A : Richmond National Insurance Co		17103
INSURER B : Pennsylvania Manufacturers' Assoc Ins Co		12262
INSURER C : Ascot Insurance Company		23752
INSURER D :		
INSURER E :		
INSURER F :		

INSURED 1521444 Oxford Towers, Inc.
1501 S. Ocean Drive
Hollywood FL 33019

COVERAGES CERTIFICATE NUMBER: 20942320 REVISION NUMBER: XXXXXXXX

THIS IS TO CERTIFY THAT THE POLICIES OF INSURANCE LISTED BELOW HAVE BEEN ISSUED TO THE INSURED NAMED ABOVE FOR THE POLICY PERIOD INDICATED. NOTWITHSTANDING ANY REQUIREMENT, TERM OR CONDITION OF ANY CONTRACT OR OTHER DOCUMENT WITH RESPECT TO WHICH THIS CERTIFICATION MAY BE ISSUED OR MAY PERTAIN, THE INSURANCE AFFORDED BY THE POLICIES DESCRIBED HEREIN IS SUBJECT TO ALL THE TERMS, EXCLUSIONS AND CONDITIONS OF SUCH POLICIES. LIMITS SHOWN MAY HAVE BEEN REDUCED BY PAID CLAIMS.

INSR LTR	TYPE OF INSURANCE	ADDL INSD	SUBR WVD	POLICY NUMBER	POLICY EFF (MM/DD/YYYY)	POLICY EXP (MM/DD/YYYY)	LIMITS
A	<input checked="" type="checkbox"/> COMMERCIAL GENERAL LIABILITY <input type="checkbox"/> CLAIMS-MADE <input checked="" type="checkbox"/> OCCUR GEN'L AGGREGATE LIMIT APPLIES PER: <input checked="" type="checkbox"/> POLICY <input type="checkbox"/> PRO-JECT <input type="checkbox"/> LOC OTHER:	Y	N	RN70500564	4/1/2024	4/1/2025	EACH OCCURRENCE \$ 1,000,000 DAMAGE TO RENTED PREMISES (Ea occurrence) \$ 50,000 MED EXP (Any one person) \$ 5,000 PERSONAL & ADV INJURY \$ 1,000,000 GENERAL AGGREGATE \$ 2,000,000 PRODUCTS - COMP/OP AGG \$ 2,000,000
A	<input type="checkbox"/> AUTOMOBILE LIABILITY <input type="checkbox"/> ANY AUTO OWNED AUTOS ONLY <input checked="" type="checkbox"/> HIRED AUTOS ONLY <input type="checkbox"/> SCHEDULED AUTOS <input checked="" type="checkbox"/> NON-OWNED AUTOS ONLY	N	N	RN70500564	4/1/2024	4/1/2025	COMBINED SINGLE LIMIT (Ea accident) \$ 1,000,000 BODILY INJURY (Per person) \$ XXXXXXXX BODILY INJURY (Per accident) \$ XXXXXXXX PROPERTY DAMAGE (Per accident) \$ XXXXXXXX
	<input type="checkbox"/> UMBRELLA LIAB <input type="checkbox"/> EXCESS LIAB DED RETENTION \$			NOT APPLICABLE			EACH OCCURRENCE \$ XXXXXXXX AGGREGATE \$ XXXXXXXX
B	<input checked="" type="checkbox"/> WORKERS COMPENSATION AND EMPLOYERS' LIABILITY ANY PROPRIETOR/PARTNER/EXECUTIVE OFFICER/MEMBER EXCLUDED? (Mandatory in NH) If yes, describe under DESCRIPTION OF OPERATIONS below	Y/N N	N/A	2024011439389Y	2/6/2024	2/6/2025	<input checked="" type="checkbox"/> PER STATUTE E.L. EACH ACCIDENT \$ 500,000 E.L. DISEASE - EA EMPLOYEE \$ 500,000 E.L. DISEASE - POLICY LIMIT \$ 500,000
C	Directors and Officers	N	N	SFD00000981	4/1/2024	4/1/2025	Limit: \$1,000,000 Deductible: \$5,000

DESCRIPTION OF OPERATIONS / LOCATIONS / VEHICLES (ACORD 101, Additional Remarks Schedule, may be attached if more space is required)
30 Days' Notice of Cancellation/Non-renewal, except 10 days for nonpayment of premium, to the certificate holder when required by written agreement.
Certificate Holder is Additional Insured in regards to General Liability as required by written contract.

CERTIFICATE HOLDER

CANCELLATION See Attachments

20942320 The Hollywood CRA 1984 Harrison Street Hollywood FL 33020	SHOULD ANY OF THE ABOVE DESCRIBED POLICIES BE CANCELLED BEFORE THE EXPIRATION DATE THEREOF, NOTICE WILL BE DELIVERED IN ACCORDANCE WITH THE POLICY PROVISIONS.
	AUTHORIZED REPRESENTATIVE

Oxford Towers, Inc.

1501 South Ocean Dr. Hollywood, FL 33019

93 Units

Property Wind Coverage:

Effective 5/31/2023 – 5/31/2024

Carrier: Citizens Property Insurance Corporation (NAIC 10064) - Policy # 072577922

Property Coverage - XWIND:

Effective - 4/01/2024 – 4/01/2025

Carrier: Wilshire Insurance Company (NAIC 13234) - Policy # IMP400071001

Limit: \$23,031,400

Valuation: Replacement Cost/Agreed Value

Policy Form: Special

Deductibles: 3% Calendar Year Hurricane, 3% All Other Wind, \$10,000 All Other Perils

Ordinance or Law: Full A, \$2,500,000 B&C Combined - (Applies to X-Wind **ONLY**)

Terrorism Excluded

Property Policy does NOT include "Walls In" Coverage

Boiler & Machinery:

Effective 4/01/2024 – 4/01/2025

Carrier: Liberty Mutual Fire Insurance Company (NAIC 23035)

Policy # YB2L9L477731014

Limit: \$23,031,400

Deductible: \$10,000

Fidelity/Crime/Employee Theft:

Effective: 6/7/2024 – 4/1/2025

Carrier: Travelers Casualty & Surety Company of America (NAIC 31194)

Policy # 106126697

Employee Theft Limit: \$150,000

Retention: \$1,000

Fidelity/Crime/Employee Theft: The Property Management Company listed on the policy is considered a covered "employee" under the policy for Employee Theft coverage while acting as an agent of the Named Insured or while in possession of covered property.

Flood: See attached declarations page.

General Liability: *Separation of Insureds is included with respect to general liability.

SELECTIVE

BE UNIQUELY INSURED®

LOCKTONCOMPANIESLLC
8110EUNIONAVESTE100
DENVER,CO80237-2966

Agency Phone: (303) 414-6000

NFIP Policy Number: 0002133728

Company Policy Number: FLD2133728

Agent: LOCKTONCOMPANIESLLC.

Payor: INSURED

Policy Term: 04/01/2024 12:01AM - 04/01/2025 12:01AM

Policy Form: RCBAP

To report a claim visit or call us at: <https://customer.myselectiveflood.com>
(877) 348-0552

RENEWAL FLOOD INSURANCE POLICY DECLARATIONS

NATIONAL FLOOD INSURANCE PROGRAM

DELIVERY ADDRESS	INSURED NAME(S) AND MAILING ADDRESS
OXFORD TOWERS INC 1501 S OCEAN DR HOLLYWOOD, FL 33019-2380	OXFORD TOWERS INC 1501 S OCEAN DR HOLLYWOOD, FL 33019-2380

COMPANY MAILING ADDRESS	INSURED PROPERTY LOCATION
Selective Ins Co of the Southeast PO BOX 782747 PHILADELPHIA, PA 19178-2747	1501 S OCEAN DR HOLLYWOOD, FL 33019-2380

RATING INFORMATION		BUILDING DESCRIPTION:	ENTIRE RESIDENTIAL CONDOMINIUM BUILDING
BUILDING OCCUPANCY:	RESIDENTIAL CONDOMINIUM BUILDING	BUILDING DESCRIPTION DETAIL:	N/A
NUMBER OF UNITS:	94 UNITS	REPLACEMENT COST VALUE:	\$26,768,400.00
PRIMARY RESIDENCE:	NO	DATE OF CONSTRUCTION:	01/01/1970
PROPERTY DESCRIPTION:	ELEVATED WITH ENCLOSURE ON POSTS, PILES OR PIERS, 16 FLOOR(S), MASONRY CONSTRUCTION	CURRENT FLOOD ZONE:	AE
PRIOR NFIP CLAIMS:	1 CLAIM(S)	FIRST FLOOR HEIGHT (FEET):	1.5
		FIRST FLOOR HEIGHT METHOD:	ELEVATION CERTIFICATE

MORTGAGEE/ADDITIONAL INTEREST INFORMATION	
FIRST MORTGAGEE:	LOAN NO: N/A
SECOND MORTGAGEE:	LOAN NO: N/A
ADDITIONAL INTEREST:	LOAN NO: N/A
DISASTER AGENCY:	CASE NO: N/A DISASTER AGENCY: N/A

RATE CATEGORY	RATING ENGINE
---------------	---------------

	COVERAGE	DEDUCTIBLE
BUILDING:	\$23,500,000	\$2,000
CONTENTS:	\$81,000	\$2,000

COVERAGES LIMITATIONS MAY APPLY. SEE YOUR POLICY FORM FOR DETAILS. Please review this declaration page for accuracy. If any changes are needed, contact your agent. Notes: The "FULL RISK PREMIUM" is for this policy term only. It is subject to change annually if there is any change in the rating elements. Your property's NFIP flood claim history can affect your premium. For questions please contact your agency. "MITIGATION DISCOUNTS" may apply if there are approved flood vents and/or the machinery & equipment is elevated appropriately. To learn more about your flood risk, please visit FloodSmart.gov/floodcosts.

COMPONENTS OF TOTAL AMOUNT DUE

BUILDING PREMIUM:	\$47,403.00
CONTENTS PREMIUM:	\$1,046.00
INCREASED COST OF COMPLIANCE (ICC) PREMIUM:	\$75.00
MITIGATION DISCOUNT:	(\$0.00)
COMMUNITY RATING SYSTEM REDUCTION:	(\$9,666.00)
FULL RISK PREMIUM:	\$38,858.00
ANNUAL INCREASE CAP DISCOUNT:	(\$0.00)
STATUTORY DISCOUNTS:	(\$0.00)
DISCOUNTED PREMIUM:	\$38,858.00
RESERVE FUND ASSESSMENT:	\$6,994.00
HFAA SURCHARGE:	\$250.00
FEDERAL POLICY FEE:	\$1,880.00
PROBATION SURCHARGE:	\$0.00
TOTAL ANNUAL PREMIUM:	\$47,982.00



This declaration page along with the Standard Flood Insurance Policy Form constitutes your flood insurance policy.

Zero Balance Due - This Is Not A Bill

Policy issued by: Selective Ins Co of the Southeast

Insurer NAIC Number: 39926



File: 30243807

Page 1 of 1



DocID: 234847473



Property Search

Search Results

Parcel Result



Homestead



Map



Sketch



Estimator



Portability



Exemption



TRIM



Tax



Pictures



Fraud



AskMarty



Print

Copy Link

New Search

< Prev Parcel

Tax Year 2024 ▼

Next Parcel >

Property Summary

Property ID: 514224AH0420

Property Owner(s): REA, CARLA LIOMI
REA, MICHAEL A

Mailing Address: 1501 S OCEAN DR #803 HOLLYWOOD,
FL 33019-2369
[click here to update mailing address](#)

Physical Address: 1501 S OCEAN DRIVE # 803
HOLLYWOOD, 33019

Neighborhood:

Property Use: 04 - Condominium

Millage Code: 0513

Adj. Bldg. S.F.: 1430 Card/Permits

Bldg Under Air S.F.: 1430

Effective Year: 1971

Year Built: 1970

Units/Beds/Baths: 1 / 2 / 2



Previous Next

Deputy Appraiser: Condo Department

Property Appraiser Number: 954-357-6832

Property Appraiser Email: condoinfo@bcpa.net

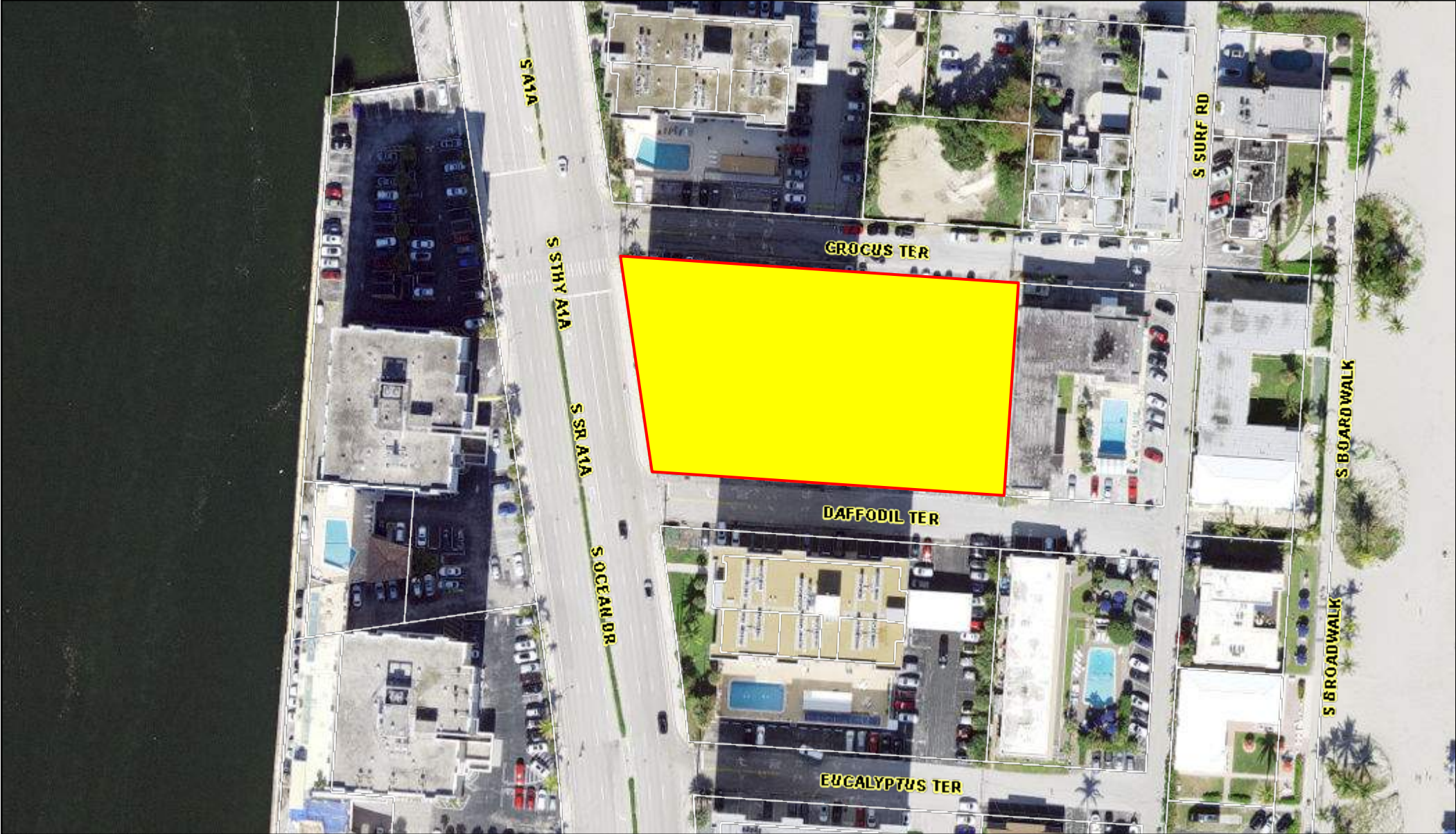

September 3, 2024

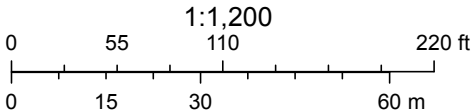

If you see a factual error on this page, please click here to notify us.

 **Important:**

The just values displayed below were set in compliance with Sec. 193.011, Fla. Stat., and include a reduction for costs of sale and other adjustments required by Sec. 193.011(8).

Property Assessment

Year	Land	Building / Improvement	Just/Market Value	Assessed / SOH Value	Tax
2024	\$48,050	\$432,430	\$480,480	\$441,570	
2023	\$45,870	\$412,860	\$458,730	\$401,430	\$9,209.08
2022	\$40,980	\$368,830	\$409,810	\$364,940	\$8,180.13

Exemptions And Taxing Authority Information

	County	School Board	Municipal	Independent
Just Value	\$480,480	\$480,480	\$480,480	\$480,480
Portability	0	0	0	0
Assessed / SOH	\$441,570	\$480,480	\$441,570	\$441,570
Homestead	0	0	0	0
Add. Homestead	0	0	0	0
Wid/Vet/Dis	0	0	0	0
Senior	0	0	0	0
Exemption Type	0	0	0	0
Affordable Housing	0	0	0	0
Taxable	\$441,570	\$480,480	\$441,570	\$441,570

Sales History For This Parcel

Date	Type	Qualified/Disqualified	Price	Book/Page or CIN
07/11/2019	Warranty Deed	Qualified Sale	\$380,000	115931496
05/29/2003	Warranty Deed		\$250,000	35377 / 1978
02/01/1995	Warranty Deed		\$130,000	23120 / 148
07/25/1994	Quit Claim Deed		\$100	23120 / 151
05/01/1994	Quit Claim Deed		\$100	22182 / 544

Recent Sales In This Subdivision ⓘ

Folio Number	Date	Type	Qualified/Disqualified	Price	Book/Page Or CIN	Property Address
514224AH0750	05/27/2024	Warranty Deed	Qualified Sale	\$575,000	119622712	1501 S OCEAN DR #1406 HOLLYWOOD, FL 33019
514224AH0570	01/25/2024	Warranty Deed	Qualified Sale	\$485,000	119359050	1501 S OCEAN DR #1006 HOLLYWOOD, FL 33019
514224AH0170	07/20/2023	Warranty Deed	Qualified Sale	\$445,000	118992163	1501 S OCEAN DR #402 HOLLYWOOD, FL 33019
514224AH0790	06/28/2023	Warranty Deed	Qualified Sale	\$590,000	119054341	1501 S OCEAN DR #1504 HOLLYWOOD, FL 33019
514224AH0780	06/20/2023	Warranty Deed	Qualified Sale	\$695,000	118939611	1501 S OCEAN DR #1503 HOLLYWOOD, FL 33019

Land Calculation

[More Sales](#) ↗

Type	Unit Price	Units	Zoning
------	------------	-------	--------

Special Assessments

Fire	Garb	Light	Drain	Impr	Safe	Storm	Clean	Misc
HLwd Fire Rescue (05)								
Residential (R)								
1								

School ⓘ

School	Grade
Hollywood Central Elementary School	C
Olsen Middle School	C
South Broward High School	C

Elected Officials

Property Appraiser	County Comm. District	County Comm. Name	US House Rep. District	US House Rep. Name
Marty Kiar	6	Beam Furr	25	Debbie Wasserman Schultz
Florida House Rep. District	Florida House Rep. Name	Florida Senator District	Florida Senator Name	School Board Member
101	Hillary Cassel	37	Jason W. B. Pizzo	Daniel P. Foganholi

Having technical issues?

Broward County Property Appraiser	About BCPA	Search	Resources	Online Tools	Exemptions & Classifications
115 South Andrews Avenue Room 111 Fort Lauderdale, Florida 33301	About Marty Kiar	Property Search	FAQ	Maps & Aerials	All Exemptions
954-357-6830	Contact Us	Tangible Search	Download Forms	Exemption Status	Agricultural Classification
martykiar@bcpa.net	Tax Roll Information	Sales Search	Related Links	Data Request	Appeals & Petitions
	Business Careers	Subdivision Search	Market Reports	Tax Estimator	Report Exemption Fraud
	Ask Marty	Time Share Search	Video Gallery	Portability Estimator	
		Commercial Search	Newsletters	Owner Alert	
		Land Search			

Privacy Policy

Having trouble viewing our website? Please contact our accessibility hotline for assistance at accessibility@bcpa.net or 954-357-6830.

Source: Broward County Property Appraiser's Office - Contact our office at 954.357.6830. Hours: We are open weekdays from 8 am until 5 pm. **Legal Disclaimer:** Under Florida law, e-mail addresses are public records. If you do not want your e-mail address released in response to a public records request, do not send electronic mail to this entity. Instead, contact this office by phone. Information provided on this website is for tax roll purposes only and may not be appropriate for other uses. Values are not final until certified pursuant to Florida law.



[Department of State](#) / [Division of Corporations](#) / [Search Records](#) / [Search by Entity Name](#) /

Detail by Entity Name

Florida Not For Profit Corporation
OXFORD TOWERS, INC.

Filing Information

Document Number	718503
FEI/EIN Number	59-1311414
Date Filed	05/14/1970
State	FL
Status	ACTIVE
Last Event	AMENDMENT
Event Date Filed	06/28/2022
Event Effective Date	NONE

Principal Address

1501 SOUTH OCEAN DRIVE
HOLLYWOOD, FL 33019

Changed: 01/26/2016

Mailing Address

1501 SOUTH OCEAN DRIVE
HOLLYWOOD, FL 33019

Changed: 04/29/2012

Registered Agent Name & Address

Eisinger Law c/o Carolina Sznajderman Sheir, Esq.
4000 Hollywood Blvd
Ste 265-South
Hollywood, FL 33021

Name Changed: 04/01/2024

Address Changed: 04/01/2024

Officer/Director Detail

Name & Address

Title VP

Zeovski, Julie
1501 SOUTH OCEAN DRIVE
HOLLYWOOD, FL 33019

Title President

Rea, Michael
1501 SOUTH OCEAN DRIVE
HOLLYWOOD, FL 33019

Title D

Garry, Bruce
1501 SOUTH OCEAN DRIVE
HOLLYWOOD, FL 33019

Title S

JOSEPH, SAMI
1501 SOUTH OCEAN DRIVE
HOLLYWOOD, FL 33019

Title Treasurer

Roth, Jason
1501 SOUTH OCEAN DRIVE
HOLLYWOOD, FL 33019

Title D

Medina, Mario
1501 SOUTH OCEAN DRIVE
HOLLYWOOD, FL 33019

Title Director

Tortorici, Pat
1501 South Ocean Drive
Hollywood, FL 33019

Annual Reports

Report Year	Filed Date
2022	01/31/2022
2023	05/08/2023
2024	04/01/2024

Document Images

04/01/2024 -- ANNUAL REPORT	View image in PDF format
05/08/2023 -- ANNUAL REPORT	View image in PDF format
06/28/2022 -- Amendment	View image in PDF format
01/31/2022 -- ANNUAL REPORT	View image in PDF format
12/03/2021 -- Amendment	View image in PDF format
08/10/2021 -- Articles of Correction	View image in PDF format
04/06/2021 -- ANNUAL REPORT	View image in PDF format
09/08/2020 -- Articles of Correction	View image in PDF format
08/21/2020 -- Amendment	View image in PDF format
04/13/2020 -- ANNUAL REPORT	View image in PDF format
02/07/2019 -- ANNUAL REPORT	View image in PDF format
06/26/2018 -- Amendment	View image in PDF format
03/26/2018 -- Amendment	View image in PDF format
01/05/2018 -- ANNUAL REPORT	View image in PDF format
01/06/2017 -- ANNUAL REPORT	View image in PDF format
03/23/2016 -- AMENDED ANNUAL REPORT	View image in PDF format
01/26/2016 -- ANNUAL REPORT	View image in PDF format
04/17/2015 -- ANNUAL REPORT	View image in PDF format
01/30/2014 -- ANNUAL REPORT	View image in PDF format
04/26/2013 -- ANNUAL REPORT	View image in PDF format
04/29/2012 -- ANNUAL REPORT	View image in PDF format
08/23/2011 -- ANNUAL REPORT	View image in PDF format
04/25/2011 -- ANNUAL REPORT	View image in PDF format
06/04/2010 -- ANNUAL REPORT	View image in PDF format
04/29/2010 -- ANNUAL REPORT	View image in PDF format
05/22/2009 -- ANNUAL REPORT	View image in PDF format
01/05/2008 -- ANNUAL REPORT	View image in PDF format
05/09/2007 -- ANNUAL REPORT	View image in PDF format
05/02/2006 -- ANNUAL REPORT	View image in PDF format
01/21/2005 -- ANNUAL REPORT	View image in PDF format
01/08/2004 -- ANNUAL REPORT	View image in PDF format
02/20/2003 -- ANNUAL REPORT	View image in PDF format
01/21/2002 -- ANNUAL REPORT	View image in PDF format
02/06/2001 -- ANNUAL REPORT	View image in PDF format
04/16/2000 -- ANNUAL REPORT	View image in PDF format
02/24/1999 -- ANNUAL REPORT	View image in PDF format
04/14/1998 -- ANNUAL REPORT	View image in PDF format
02/07/1997 -- ANNUAL REPORT	View image in PDF format
03/21/1996 -- ANNUAL REPORT	View image in PDF format
04/07/1995 -- ANNUAL REPORT	View image in PDF format





1901

OXFORD TOWERS

NO



FOCUS TERRACE

CONSENT TO ACTION WITHOUT MEETING OF THE BOARD OF DIRECTORS

Written consent to action without meeting of the board of directors of Oxford Towers, Inc (the "Corporation" dated this 16 day of September, 2024

BACKGROUND:

- A. The Corporation is a corporation organized and operating under the laws of the State of Florida.
- B. The directors have determined that it is in the best interest of the Corporation to set the signing officers of the Corporation for its various accounts.
- C. The directors have determined that it is in the best interest of the Corporation to appoint certain officers for the Corporation.
- D. The directors consider that it is in the best business interest of the Corporation to enter into a certain contract.

IT WAS RESOLVED THAT:

- 1. The following individuals are appointed and confirmed as signing officers for the Corporation for a term of one year or until replaced and are authorized to manage bank accounts that have been established for the benefit of the Corporation, sign and endorse checks, drafts, and other orders of payment for those bank accounts, and are authorized to sign bills of lading, and other documents, as needed and reasonable, for the normal conduct of the business of the Corporation:

Michael Rea
Sami Joseph

- 2. The following individual is appointed and confirmed as an officer of the Corporation for a term of one year or until replaced:

Michael Rea, President

- 3. The officers and directors are authorized to enter into the following contract (the "Contract"):

Whatever the Owner deems necessary at the time of the contract.

Any one officer or director is authorized to execute the Contract on behalf of the Corporation.

4. Any one director or officer of the Corporation is authorized to sign all documents and perform such acts as may be necessary or desirable to give effect to the above resolutions.
5. The Secretary of the Corporation is directed to update the minute book of the Corporation, as appropriate.
6. This resolution may be executed in counterparts. Facsimile, scanned, or electronic signatures are binding and are considered to be original signatures.

Dated in the State of Florida on the _____ day of _____, _____.

(Signature)
Michael Rea

(Signature)
Jason B. Roth

(Signature)
Sami Joseph



HOLLYWOOD CRA GRANT PROGRAM BID SUMMARY

Business or Condo Name: **OXFORD TOWERS, INC.**

Property Address: **1501 South Ocean Dr. Hollywood FL 33019**

PIP

WORK DISCIPLINE: General Contractor (Concrete Restoration, Railings, Paint & Stucco, Structural Work)

Contractor .001 Florida Choice Contracting	\$4,411,971.75	SELECTED
Contractor .002 Lindman Companies	\$7,643,064.06	
Contractor .003 Restore Construction Group	\$5,707,002.68	
Contractor .004 Valcourt Building Services	\$5,576,637.84	

WORK DISCIPLINE: Exterior Lighting (Turtle Friendly)

Contractor .001 K&I ELECTRIC INC	\$58,942.68	SELECTED
Contractor .002 Moody Electrical	\$148,050.00	
\$67,200 (wall boxes) + \$55,000 (New Wall Sconces) + \$25,850 = \$148,050.00 (Demo not Included)		
Contractor .003 NAME	\$0.00	

Bid Summary Continues On Next Page

NOTES:



HOLLYWOOD CRA GRANT PROGRAM BID SUMMARY

Business or Condo Name: **OXFORD TOWERS, INC.**

Property Address: **1501 South Ocean Dr. Hollywood FL 33019**

PIP

WORK DISCIPLINE: Exterior Painting & Stucco

Contractor .001 Florida Choice Contracting*	\$413,715.75	SELECTED
--	---------------------	-----------------

**included in Florida Choice Contracting's total fee*

Contractor .002 A-BEST Painting \$66,444.00

Contractor .003 M&A Professional Painting \$77,922.00

Contractor .003 Marvelous Painting \$26,800.00

WORK DISCIPLINE: Asphalt (Parking Lot Repaving)

Contractor .001 All American Asphalt LLC	\$6,500.00	SELECTED
---	-------------------	-----------------

Contractor .002 RnR Sealcoating \$7,500.00

Contractor .003 US PAVE \$8,123.00

TOTAL PROJECT COST

\$4,477,414.43

Out of Pocket

\$4,327,414.43

TOTAL INCENTIVE AMOUNT

2%

\$75,000.00

(Up To 50% Of Total Project Cost With A \$75,000 Max)

End of Bid Summary

NOTES: Total Project Cost = General Contractor Scope + Electrical + Asphalt



PROPOSAL NUMBER

#4209-1

JOB NAME AND ADDRESS

**Oxford Towers
1501 S Ocean Dr
Hollywood, FL 33019**

CLIENT

**American Property Management
10631 N Kendall Dr 1205
Miami, FL 33176**

CONTACT

**786-444-3748
csr@americanmgmtgroup.com
Ana Gutierrez**

PROJECT PROPOSAL

6/18/2024

ADDRESS

3200 DAVIE BLVD
FORT LAUDERDALE, FL
33312

TELEPHONE

830-660-0687 Cell
888-681-9355 office

SALESPERSON

REEVES MUNDSCHAU

EMAIL

REEVES@USPAVE.COM

PROPOSAL

Dear Ana Gutierrez,

U.S. Pave provides a complete range of innovative commercial and residential paving solutions. Our sense of innovation is matched only by our strong dedication to providing the most advanced products and the highest-quality services in the industry. We take great pride in our extensive technical expertise and share our knowledge of the trade to empower you to make informed decisions. We take the time to understand your objectives and make recommendations based on your needs. By working together every step of the way, we can safely and accurately execute your goals, all within budget and with the greatest long-term return on investment.

At U.S. Pave, no job is complete until you are completely satisfied.

We propose, as per direction, to perform the following work: Labor, Materials, Equipment

Exclusions: Testing, Towing, Permitting and procurement, 3rd Party Inspections, Material Testing, Engineering, Sod Restoration & Landscaping, Vegetation Removal, Staking, Manhole/Catch Basin/Gate Valve Adjustments or Repairs, SAC/WAC Charges, Dewatering, Removal Or Relocation Of Utilities, Any Other Items As Listed On The Terms And Conditions Page.

Please review the proposal and feel free to call with any questions.

PROPOSAL

SEALCOAT 2 COATS WITH TREADCOAT™

Sealcoat, Two Separate Coats Using TreadCoat™, Up To 26,000 SF

1. Block off and barricade specific predetermined areas to sealcoat.
2. Clean entire asphalt surface thoroughly using power air blowers and power hand brooms.
3. Treat all heavy oil spots with bond seal to help separate carbon layers and for better adhesion to the asphalt pavement surface.
4. Administer the initial coat of U.S. Pave's TreadCoat™ sealer. This coal tar-based sealing agent is fortified with micronized recycled tire rubber, refined to a particle size 0.4mm - 4 microns to optimize integration with the latex and coal tar sealer components. A latex additive is incorporated to enhance the formulation's elasticity, bolster abrasion resistance, and ensure uniform dispersion of the ground tire rubber (GTR) within the matrix. The mixture is subsequently subjected to a superheating stage to achieve superior homogenization of the components. Continuous shearing mechanical agitation is utilized to maintain consistent distribution of the sealer, which contains a minimum of 1.2 pounds at micron level and 1.3 pounds at mesh level size of high-grade GTR per gallon. The coal tar formulation is uniformly administered to the asphalt substrate at a controlled application rate of approximately 1/5 to 1/6 gallons per square yard.
5. Apply the second separate coat with sand using the same quantity, proportion and application method as the first coat.

- SEALCOATING TO BE COMPLETED IN (2) MOBILIZATIONS.
- BARRICADES WILL BE PROVIDED TO CLOSE OFF ALL AREAS OF CONSTRUCTION. U.S. PAVE IS NOT RESPONSIBLE FOR PERSONS OR VEHICLES ENTERING THE DESIGNATED/BARRICADED AREAS AND TRACKING SEALER OR PAINT, CAUSING INJURY TO SELF OR OTHERS, OR DAMAGE TO PROPERTY.
- U.S. PAVE IS NOT RESPONSIBLE FOR DAMAGES TO UNDERGROUND UTILITIES, PIPES, IRRIGATION, SOD, NOR LANDSCAPE IN AND AROUND AREAS OF CONSTRUCTION.
- SEALER MAY NOT ADHERE TO AREAS OF POLISHED AGGREGATE / RAVELING ASPHALT.
- PERMIT FEES / PROCUREMENT FEES / ENGINEERING OR ANY ADDITIONAL WORK REQUIRED BY THE PERMIT WILL BE AN ADDED COST TO THE CUSTOMER.
- PRICE IS BASED ON PERFORMING ALL WORK PROPOSED, AND IS GOOD FOR 30 DAYS.
- SEALER WILL NOT HIDE EXISTING CRACKS.

Price: \$6,248.00

STRIPING - RESTRIPE

Parking Lot Striping

- 1. Clear away any loose dirt or debris
- 2. Restripe as existing using D.O.T. approved latex traffic paint, to include: Stall Lines, 6" lineal feet, Stop Bars, Speed Bumps

****THE DISABLED PARKING STALLS ARE BEING RESTRIPE AS THEY PRESENTLY EXIST. THIS CONTRACTOR MAKES NO CLAIM THAT THEY WILL MEET LOCAL, STATE AND FEDERAL REQUIREMENTS FOR DISABLED PARKING.**

****THIS CONTRACTOR WILL NOT BE RESPONSIBLE FOR PAINT PEELING OR FLAKING OFF CONCRETE SURFACES.**

Price: \$1,875.00

TOTAL PRICE OF THIS PROPOSAL AS PRESENTED:

\$8,123.00

AGREEMENT

U.S. Pave™ proposes to furnish material and labor to perform the work outlined herein for the sum of:

\$8,123.00, EIGHT THOUSAND, ONE HUNDRED TWENTY-THREE DOLLARS AND ZERO CENTS

Payment is to be made as follows: • 50% upon acceptance • 50% upon completion

This proposal is valid for thirty (30) days from the date written above. The proposal is subject to the terms and conditions enclosed, attached and/or on the backside of the proposal.

This proposal contains confidential information belonging to the sender, which is legally privileged. The information is intended only for the use of the individual or entity named above. If you are not the intended recipient, you are hereby notified that any disclosure, copying, distribution or the taking of any action in reliance on the contents of this proposal is strictly prohibited. If you have received this proposal in error, please immediately notify us by telephone to arrange for return of the original documents to us.

Sincerely,

Reeves Mundschau,
reeves@uspave.com
Cell: 830-660-0687

Accepted: The above proposed terms and conditions, including price and payment terms are satisfactory and hereby accepted. **U.S. Pave™** is hereby authorized to proceed with the work specified.

Purchaser: _____ Title: _____

Printed Name: _____ Date: _____

TERMS & CONDITIONS

- These Terms and Conditions are by and between U.S. Pave (hereinafter the "Contractor"), and the front-side "Purchaser", (hereinafter the "Purchaser").
- All stone asphalt and concrete depths indicated are to be interpreted as average depths prior to compaction. Actual asphalt repair depth, regardless of depth specified on the front, will only go to the lime rock base, or specified depth, whichever is less.
- Drainage is not guaranteed on areas without adequate slope. In flat areas water will not drain unless there is more than 1-1/2' of fall per 10 feet.
- If contract is cancelled by Purchaser prior to commencement of work, Purchaser will pay Contractor twenty percent (20%) of total contract price.
- Unit prices, if specified, shall apply to all extra work performed beyond the original scope, if such work can be performed at the same time Contractor is working at the site on original items of work. Contractor reserves the right to renegotiate the terms and conditions, including price if it must move any equipment back to the site to perform additional work. Contractor will be under no obligation to perform any extra work.
- All proposals are based on the existence of workable sub-base layer of at least four (6) inches. It shall not be Contractor's responsibility to check sub-base unless it is specified and paid for in the contract. Contractor shall not be responsible for consequences of sub-base deficiency or failures, including but not limited to damages or inability to perform work due to poor compaction, underground springs, buried materials, grade failures, etc.
- Each phase of work will be billed upon completion of that phase. Purchaser agrees to pay all invoices within 15 days of the invoice date. All amounts unpaid by the due date shall bear interest at the rate of 1.5% per month until paid. If full payment (including aforementioned late charges) has not been received by Contractor within 45 days of substantial completion, all of Purchaser's warranty rights hereunder will be forfeited and automatically become void and Contractor shall be excused from further performance of work under this proposal, or any other contract with Purchaser and all amounts then due and owing, including retainage, shall become immediately payable.
- The pricing contained and agreed to herein, is based on all work being completed within 30 days of the date of this proposal unless otherwise agreed in writing. The terms for doing any work after this date may, at Contractor's option, be renegotiated between Contractor and Purchaser. To the extent Contractor has performed any work within 30 days of the date of this proposal, Contractor shall be compensated for all such work under the terms and conditions and including price as set forth in this proposal, including retainage, together with any costs incurred as a result of Purchaser's delay in completion of the work. Purchaser agrees to compensate Contractor for ALL reasonable costs (and associated overhead and profit) for delays incurred completing the work.
- Purchaser shall not prematurely subject the work to any type of traffic; loads in excess of the design capacity before proper cure, or in a manner which may damage the work. Contractor is not responsible for graffiti, tire tracks, animal or human footprints, etc., on finished concrete/asphalt.
- Although contractor will endeavor to cooperate fully with the progress of the work, it reserves the right to delay the start of work until the entire area of the job is ready to be poured, paved or sealed. Unless otherwise noted, the total price is based on one move-in/mobilization and complete access to work areas at the time of move-in/mobilization. Purchaser agrees to pay Contractor \$2,500.00 for each additional move-in/mobilization. The removal of vehicles from the work site is the sole responsibility of the Purchaser. Damage to vehicles left on the work site is the responsibility of the Purchaser. Contractor is not responsible for crackfill that adheres to tires. Contractor is not responsible for overspray on vehicles, curb and gutter, and all structures within 50 feet of the edge of parking lot and or area being sealed or treated.
- Unless expressly noted within the agreement, U.S. Pave makes no claim to the local, state, or federal compliance of any and all ADA elements present within the property boundary.
- Contractor shall not be bound to any construction schedules unless agreed to in writing by Contractor. If no schedule is established, Contractor will undertake the work in the course of its normal operating schedule.
- Purchaser to ensure all existing surfaces shall be in a condition suitable to receive any work to be performed by Contractor. Purchaser shall provide potable water and electrical source at no expense to Contractor. Contractor is not responsible for tire marks/scuffs on asphalt and or concrete. Contractor is not responsible for damage to sod, landscaping and sidewalks due to required access by trucks and or equipment. Contractor is not responsible for

damage to existing asphalt pavement due to weak, unstable, non-compacted or wet sub-base materials. Contractor is not responsible for damage to surrounding concrete due to vibration of jackhammers and equipment.

- To the extent that the work is dependent upon work of other contractors or subcontractors, Contractor shall not assume responsibility for any defect, deficiency, or non-compliance in such other work.
- Purchaser is responsible for getting all "private" (non-public) utilities, including wells and septic system elements, underground sprinklers systems, electrical wiring, etc marked by an independent utility locator prior to the commencement of work. All specifications and the work estimate are conditioned on all private utilities not being disturbed or changed by modifications needed to accommodate private utilities not disclosed to Contractor previously. Any damage caused to private lines during construction is the sole responsibility of Purchaser unless previously marked by independent utility locator and are buried to code. Purchaser is responsible for all damage to existing structures and facilities, including underground utilities, caused by equipment necessary to carry out the work.
- Contractor will not be responsible for construction or material failures or delays in construction caused by any factor beyond its control, including, but not limited to, delays or failures caused by weather, acts of God, delays in transportation, acts of suppliers and subcontractors, acts of the Purchaser, Owner or its separate contractors, fuel or raw material shortages, plant failures, or any other cause beyond its control.
- Unless stated in writing on this proposal, all engineering and testing, subgrade stabilization (undercut), excavation, utilities, adjustment of underground facilities, manholes, water valves, or underground structures, striping, landscaping, permits, bonds, government approvals, damage to existing asphalt and concrete and landscaping shall be Purchaser's sole responsibility. Purchaser agrees to indemnify, protect, and hold Contractor harmless from any and all damages, expenses and attorneys fees suffered or incurred on account of Purchaser's breach of any obligation or covenant of this proposal.
- Unless stated in writing on this proposal, there shall be no warranties, express or implied, in connection with any material or service furnished under this proposal. All consequential damages are excluded.
- In the event that Contractor retains an attorney to recover any amount due under this agreement, the Purchaser agrees to pay all attorney fees, court costs and costs of collection incurred by Contractor.
- Purchaser will, prior to Contractor leaving the job site, arrange for an authorized representative or agent of the Purchaser to inspect completed Contractor work in the company of a Contractor representative. Purchaser's failure to inspect job site as above will signify acceptance of work performed by Contractor and agreement to pay the bill in full within fifteen (15) days.

NOTICE OF LIEN: ANY PERSON OR COMPANY SUPPLYING LABOR OR MATERIALS FOR THIS PROJECT / IMPROVEMENT TO YOUR PROPERTY, MAY FILE A LIEN AGAINST YOUR PROPERTY, IF THAT PERSON OR COMPANY IS NOT PAID FOR THEIR CONTRIBUTIONS.

Customer Initial _____ . Date _____ .



CERTIFICATE OF LIABILITY INSURANCE

DATE (MM/DD/YYYY)

3/6/2024

THIS CERTIFICATE IS ISSUED AS A MATTER OF INFORMATION ONLY AND CONFERS NO RIGHTS UPON THE CERTIFICATE HOLDER. THIS CERTIFICATE DOES NOT AFFIRMATIVELY OR NEGATIVELY AMEND, EXTEND OR ALTER THE COVERAGE AFFORDED BY THE POLICIES BELOW. THIS CERTIFICATE OF INSURANCE DOES NOT CONSTITUTE A CONTRACT BETWEEN THE ISSUING INSURER(S), AUTHORIZED REPRESENTATIVE OR PRODUCER, AND THE CERTIFICATE HOLDER.

IMPORTANT: If the certificate holder is an ADDITIONAL INSURED, the policy(ies) must have ADDITIONAL INSURED provisions or be endorsed. If SUBROGATION IS WAIVED, subject to the terms and conditions of the policy, certain policies may require an endorsement. A statement on this certificate does not confer rights to the certificate holder in lieu of such endorsement(s).

PRODUCER Bateman Gordon and Sands 3050 North Federal Hwy. Lighthouse Point FL 33064	CONTACT NAME: Eric Gonzales PHONE (A/C, No, Ext): 954-941-0900 E-MAIL ADDRESS: egonzales@bgsagency.com		FAX (A/C, No): 954-941-2006
	INSURER(S) AFFORDING COVERAGE		
INSURED U.S. Asphalt LLC dba U.S. Pave 3200 Davie Blvd. Fort Lauderdale FL 33312	USASP	INSURER A : Monroe Guaranty Insurance Compnay	
		INSURER B : Brierfield Insurance Company	
		INSURER C : National Trust Insurance Company	
		INSURER D : FCCI Insurance Company	
		INSURER E :	
		INSURER F :	

COVERAGES

CERTIFICATE NUMBER: 97115430

REVISION NUMBER:

THIS IS TO CERTIFY THAT THE POLICIES OF INSURANCE LISTED BELOW HAVE BEEN ISSUED TO THE INSURED NAMED ABOVE FOR THE POLICY PERIOD INDICATED. NOTWITHSTANDING ANY REQUIREMENT, TERM OR CONDITION OF ANY CONTRACT OR OTHER DOCUMENT WITH RESPECT TO WHICH THIS CERTIFICATE MAY BE ISSUED OR MAY PERTAIN, THE INSURANCE AFFORDED BY THE POLICIES DESCRIBED HEREIN IS SUBJECT TO ALL THE TERMS, EXCLUSIONS AND CONDITIONS OF SUCH POLICIES. LIMITS SHOWN MAY HAVE BEEN REDUCED BY PAID CLAIMS.

INSR LTR	TYPE OF INSURANCE	ADDL INSD	SUBR WVD	POLICY NUMBER	POLICY EFF (MM/DD/YYYY)	POLICY EXP (MM/DD/YYYY)	LIMITS
A	<input checked="" type="checkbox"/> COMMERCIAL GENERAL LIABILITY <input type="checkbox"/> CLAIMS-MADE <input checked="" type="checkbox"/> OCCUR <input checked="" type="checkbox"/> PD Dec: \$5,000 GEN'L AGGREGATE LIMIT APPLIES PER: <input type="checkbox"/> POLICY <input checked="" type="checkbox"/> PRO-JECT <input type="checkbox"/> LOC <input type="checkbox"/> OTHER:	Y	Y	GL10009068900	3/1/2024	3/1/2025	EACH OCCURRENCE \$ 1,000,000 DAMAGE TO RENTED PREMISES (Ea occurrence) \$ 100,000 MED EXP (Any one person) \$ Excluded PERSONAL & ADV INJURY \$ 1,000,000 GENERAL AGGREGATE \$ 2,000,000 PRODUCTS - COMP/OP AGG \$ 2,000,000 \$
B	<input checked="" type="checkbox"/> AUTOMOBILE LIABILITY <input checked="" type="checkbox"/> ANY AUTO <input type="checkbox"/> OWNED AUTOS ONLY <input type="checkbox"/> SCHEDULED AUTOS <input checked="" type="checkbox"/> HIRED AUTOS ONLY <input checked="" type="checkbox"/> NON-OWNED AUTOS ONLY	Y	Y	CA10009069000	3/1/2024	3/1/2025	COMBINED SINGLE LIMIT (Ea accident) \$ 1,000,000 BODILY INJURY (Per person) \$ BODILY INJURY (Per accident) \$ PROPERTY DAMAGE (Per accident) \$ \$
C	<input checked="" type="checkbox"/> UMBRELLA LIAB <input checked="" type="checkbox"/> OCCUR <input type="checkbox"/> EXCESS LIAB <input type="checkbox"/> CLAIMS-MADE <input type="checkbox"/> DED <input checked="" type="checkbox"/> RETENTION \$ 10,000	Y	Y	UMB10009072700	3/1/2024	3/1/2025	EACH OCCURRENCE \$ 2,000,000 AGGREGATE \$ 2,000,000 \$
D	<input checked="" type="checkbox"/> WORKERS COMPENSATION AND EMPLOYERS' LIABILITY ANY PROPRIETOR/PARTNER/EXECUTIVE OFFICER/MEMBER EXCLUDED? <input type="checkbox"/> Y <input checked="" type="checkbox"/> N (Mandatory in NH) If yes, describe under DESCRIPTION OF OPERATIONS below		Y	WC010009072300	3/1/2024	3/1/2025	<input type="checkbox"/> PER STATUTE <input type="checkbox"/> OTH-ER E.L. EACH ACCIDENT \$ 1,000,000 E.L. DISEASE - EA EMPLOYEE \$ 1,000,000 E.L. DISEASE - POLICY LIMIT \$ 1,000,000
B	Leased/Rented Equipment			CM10009069100	3/1/2024	3/1/2025	Limit: \$100,000 Crane Deductible: \$5,000 Batch Plant Equip Ded \$5,000 Deductible: \$1,000 \$5,000

DESCRIPTION OF OPERATIONS / LOCATIONS / VEHICLES (ACORD 101, Additional Remarks Schedule, may be attached if more space is required)

General Liability: Additional Insured with On-going and Completed Operations, & Primary and Non-Contributory status, as required by written contract, per form CGL084(02/21); Waiver of Subrogation, as required by written contract, per form CGL088(02/21).
 Automobile Liability: Additional Insured and Waiver of Subrogation, as required by written contract, per form CAU058(10/22).
 Umbrella Liability: Extends coverage to underlying General Liability coverages.
 Workers' Compensation: Waiver of Subrogation as required by written contract, per WC000313(4/84).
 ALL COVERAGES SUBJECT TO THE POLICY TERMS, CONDITIONS AND EXCLUSIONS.

CERTIFICATE HOLDER**CANCELLATION**

PROOF OF INSURANCE ONLY IF ORIGINAL CERT IS NEEDED PLEASE CONTACT NAMED INSURED . . .	SHOULD ANY OF THE ABOVE DESCRIBED POLICIES BE CANCELLED BEFORE THE EXPIRATION DATE THEREOF, NOTICE WILL BE DELIVERED IN ACCORDANCE WITH THE POLICY PROVISIONS.
	AUTHORIZED REPRESENTATIVE

© 1988-2015 ACORD CORPORATION. All rights reserved.

DATE:	FLORIDA CHOICE CONTRACTING BASE BID UNIT PRICES AND BID AMOUNTS OXFORD TOWERS 50-YR RECERT. REPAIRS 1501 SOUTH OCEAN DRIVE, HOLLYWOOD, FL 33019 July 1, 2024	 2121 Fillmore St, Hollywood, FL 33020 Phone # 954-923-0014 C.G.C.# 1515037
-------	--	---

GENERAL CONDITIONS COST: STRUCTURAL

DATE 5/28/2024

PRINTED: July 1, 2024

	Item No.		Bid Quantity [A1]	Unit	LUMP SUM WORK
General Conditions I	GC-1	Contractor shall mobilize and demobilize as necessary to perform the entire scope of work.	1	Lump Sum	\$ 106,960.00
	GC-2	Contractor shall be responsible for general conditions including protection of existing building and façade, protection of existing building finishes, weather protection, temporary support, project administration, debris containment, barriers, swing stage rentals, shoring, etc. General conditions are divided equally monthly.	1	Lump Sum	\$ 276,240.00
	GC-3	Contractor shall provide photographic documentation of existing conditions property and all areas that will be affected by construction work (including pool, parking garage, staging areas etc.)	1	Lump Sum	\$ 3,000.00
	GC-4	Contractor shall provide as-built drawings for unit price work performed on each payment application.	1	Lump Sum	INCLUDED
	GC-5	Temporary facilities	1	Lump Sum	INCLUDED
	GC-6	Protection of existing sliding glass doors, swing doors, and window frame systems with self-adhering protective film.	1	Lump Sum	INCLUDED
	GC-7	Contractor to provide shoring engineer drawings to support the structure during all demolition and put back activities in accord with the plans. Designated shoring locations as per engineer's drawings. Structural components requiring shoring such as slabs, walls, beams, etc. identified on engineer's drawings. Shoring post to have a minimum of 5 kip performance. All columns shall be braced prior to any demolition.	1	Allowance	\$ 25,000.00
	GC	Subtotal - General Conditions I			\$ 411,200.00
	GC-8	Obtain all permits necessary to permit the scope of work (excluding expediting). NOTE: Cost Expedition Fee Plus 20%	1	Cost Expedition Fee Plus 20%	
	GC-9	Payment and Performance Bond/Labor and Material Bond		2.50%	
	GC-10	Permit Expeditor	1	Lump Sum	\$ 1,000.00

Contractor is solely responsible for estimating quantities of all items listed as Lump Sum

SECTION 00300 - BID FORM
 BASE BID UNIT PRICES AND BID AMOUNTS
 OXFORD TOWERS ajustadoXboardJN 26jun20 Oxf
 BID FORM REVISION 1

LUMP SUM WORK COST

	Item No.	Description	Reference	Bid Quantity [A1]	Unit	LUMP SUM WORK
STUCCO PAINT AND SEALANTS	PS-01	EXTERIOR STUCCO PAINT: Repaint the entire exterior of the building in accordance with TT's specifications. Paint to match existing color and texture. Work to include power washing the entire building, surface preparation on all stucco and concrete, surface conditioner, hot primer, primer, all in accordance with specifications and manufacturer recommendations, and a TWO-COAT paint system. Paint areas includes columns, walls, ceilings, balconies and all other elements at the exterior that are currently painted. NOTE: EXTERIOR PAINTING SPECIFICATION Prepared by: BENJAMIN MOORE PAINTS February 27, 2024	SPEC 99100	1	Lump Sum	\$ 289,635.90
	PS-02	BEAUTY BEAD SEALANTS: Total replacement of all secondary "beauty bead" sealant at ALL existing sliding glass doors, swing doors, window frame systems, louvers, and other penetrations.	SPEC 79200 SHEET S4-401	1	Lump Sum	\$ 93,127.50
	PS-03	INTERIOR STUCCO PAINT: Repaint the entire INTERIOR of the building east and west staircases in accordance with the specifications. Paint to match existing color and texture. Work to include power wash, surface preparation on all stucco and concrete , surface conditioner, hot primer, primer, all in accordance with specifications and manufacturer recommendations, and a ONE-COAT paint system. Paint areas includes columns, walls, ceilings, and all other elements at the staricases that are currently painted.	CONTRACTOR SUBMIT INTERIOR PAINT PRODUCT	1	Lump Sum	\$ 30,952.35
	PS	Subtotal - Stucco Paint and Sealants				
TOWER BALCONIES	TB-01	BALCONY TILE REMOVAL. Contractor shall remove and dispose of ALL tile and overburden from approx. four balconies. Contractor measured 652 SF.	-	1	Lump Sum	\$ 4,564.00
	TB-02 ALT-20YR	BALCONY WATERPROOFING: Contractor shall remove existing waterproofing membrane, grind down surface and prepare ALL horizontal balcony decks in accordance with manufacture recommendation but no less than a CSP 3 to 5. Contractor shall install UV stable waterproofing assembly WITH A 20 YEAR WITH ALCHEMO: TECHCRETE 2500 WATERPROOFING SYSTEM FOR CONCRETE MANUFACTURER WARRANTY in accordance with TT's specifications and manufacturer recommendations. with STO DECOCOAT TOP COAT VIF	CONTRACTOR TO SUBMIT SPECIFICATIONS FOR BOTH WATERPROOFING AND STO DECOCOAT	1	Lump Sum	\$ 432,000.00

Contractor is solely responsible for estimating quantities of all items listed as Lump Sum

SECTION 00300 - BID FORM
 BASE BID UNIT PRICES AND BID AMOUNTS
 OXFORD TOWERS ajustadoXboardJN 26jun20 Oxf
 BID FORM REVISION 1

LUMP SUM WORK COST (CONT)

	Item No.	Description	Reference	Bid Quantity [A1]	Unit	LUMP SUM WORK
TOWER BALCONIES	TB-03	A. RAILING REPLACEMENT (GLASS: Exterior Glass Configuration GIG): Remove and replace existing aluminum railing AT ALL BALCONIES with new aluminum railing, include railing at east/west entrances and pool entrances. Shop drawings by delegated engineer to be provided for review and approval, along with submittal to building department if necessary. Design to be in accordance with FBC Ch. 10 and FBC Ch. 16 requirements. Includes all slab reinforcement bars, sealants and fasteners required for installation of railings.	CONTRACTOR TO SUBMIT SPECIFICATION	1	Lump Sum	\$ 999,359.14
		OPTION: B. RAILING REPLACEMENT (GLASS: INTERIOR Glass Configuration IG): Remove and replace existing aluminum railing AT ALL BALCONIES with new aluminum railing, include railing at east/west entrances and pool entrances. Shop drawings by delegated engineer to be provided for review and approval, along with submittal to building department if necessary. Design to be in accordance with FBC Ch. 10 and FBC Ch. 16 requirements. Includes all slab reinforcement bars, sealants and fasteners required for installation of railings.	CONTRACTOR TO SUBMIT SPECIFICATION	1	Lump Sum	\$ 974,929.00
	TB-03 ALT	OPTION C. RAILING REPLACEMENT (ALUMINUM PICKET): Remove and replace existing aluminum railing AT ALL BALCONIES with new aluminum railing, include railing at east/west entrances and pool entrances. Shop drawings by delegated engineer to be provided for review and approval, along with submittal to building department if necessary. Design to be in accordance with FBC Ch. 10 and FBC Ch. 16 requirements. Includes all slab reinforcement bars, sealants and fasteners required for installation of railings. For bidding purposes consider a 3-line, single opening peak-a-boo railing style.	SPEC 57230 SHEET S4-201, S1-202	1	Lump Sum	\$ 533,600.00
	TB-04	SHUTTERS REMOVAL: Contractor shall remove shutters/shades as directed by EOR. This line item includes repair for embedded anchors. 160 Shutters x 6 LF = 960	S3-104	960	LF	\$ 46,650.00
	TB	Subtotal - Balcony Waterproofing Paint and Sealants				\$ 1,016,814.00

Contractor is solely responsible for estimating quantities of all items listed as Lump Sum

SECTION 00300 - BID FORM
 BASE BID UNIT PRICES AND BID AMOUNTS
 OXFORD TOWERS ajustadoXboardJN 26jun20 Oxf
 BID FORM REVISION 1

TOWER	TW-01-ATL 20YR	EAST STAIRS FOYER SLAB WATERPROOFING: Contractor shall remove existing waterproofing membrane, grind down surface and prepare ALL slabs and ALL FLOORS in accord with manufacturer recommendation but no less than a CSP 3 to 5. Contractor shall install UV stable waterproofing assembly WITH A 20 YEAR WITH ALCHEMO: TECHCRETE 2500 WATERPROOFING SYSTEM FOR CONCRETE WITH THE MAPEI COAT DECK S AND DECK T.	CONTRACTOR TO SUBMIT SPECIFICATION	1	Lump Sum	\$	7,040.00
	TW-05A 20- YR	EAST ENTRANCE ROOF REPLACEMENT - Contractor shall remove existing waterproofing membrane, grind down surface and prepare ALL SURFACES in accord with manufacturer recommendation but no less than a CSP 3 to 5. Contractor shall install UV stable waterproofing assembly in TECHCRETE 2500 WITH A 20 YEAR MANUFACTURER WARRANTY TECHCRETE 2500 WATERPROOFING SYSTEM FOR CONCRETE WITH THE MAPEI COAT DECK S AND DECK T.	CONTRACTOR TO SUBMIT SPECIFICATION	1	Lump Sum	\$	16,992.00
	TW-05B 20- YR	WEST ENTRANCE ROOF REPLACEMENT - Contractor shall remove existing waterproofing membrane, grind down surface and prepare ALL SURFACES in accord with manufacturer recommendation but no less than a CSP 3 to 5. Contractor shall install UV stable waterproofing assembly TECHCRETE 2500 WITH A 20 YEAR MANUFACTURER WARRANTY TECHCRETE 2500 WATERPROOFING SYSTEM FOR CONCRETE WITH THE MAPEI COAT DECK S AND DECK T.	CONTRACTOR TO SUBMIT SPECIFICATION	1	Lump Sum	\$	5,440.00
	TW	Subtotal - Common Areas Lump Sum Work				\$	29,472.00

LUMP SUM WORK COST (CONT)

	Base Bid Lump Sum Total
--	--------------------------------

Contractor is solely responsible for estimating quantities of all items listed as Lump Sum

SECTION 00300 - BID FORM
 BASE BID UNIT PRICES AND BID AMOUNTS
 OXFORD TOWERS ajustadoXboardJN 26jun20 Oxf
 BID FORM REVISION 1

UNIT ITEMS WORK COST

FLORIDA CONTRACTING

	Item No.	Description	ADJUSTED QUANTITY	Bid Quantity [A1]	Unit	UNIT PRICE WORK	
						Unit Price [B1]	Bid Amount [A1 x B1]
HURRICANE, WEATHER WALLS AND MISC. PROTECTION	PR-01	WEATHER WALL - Contractor shall install a temporary wall for weather protection on the interior side of <u>Sliding Glass Doors</u> (Medium and Corner Balconies). Wall shall be water tight and resist prescribing wind loads. Work to include shoring below. Consider a 100-inch wide Sliding Glass Door. Delegated Engineer Required	12	12	EA	\$ 1,140.00	\$ 13,680.00
	PR-02	WEATHER WALL - Contractor shall install a temporary wall for weather protection on the interior side of <u>Swing Doors</u> (Small Balconies). Wall shall be water tight and resist prescribing wind loads. Work to include shoring below. Consider a 24-inch wide swing door. Delegated Engineer Required.	12	12	EA	\$ 380.00	\$ 4,560.00
	PS	Subtotal - Protection					\$ 18,240.00
AC STANDS	AC-01	AC UNITS ON BALCONIES FLOOR 2 THRU 7 (6 PER FLOOR, 36 TOTAL). Disconnect, temporarily relocate, and reconnect, and reinstall AC units on balconies with final AC connection, Consider Replacement of the AC stand Support base with a NEW wall mounted stand.	36	36	EA	\$ 1,740.00	\$ 62,640.00
	AC	Subtotal - AC UNITS RELOCATION					\$ 62,640.00
Concrete Repairs	CR-01	CONCRETE REPAIR AT SLAB EDGE. REMOVE 12" WIDE X 6" DEEP FULL LENGTH OF BALCONY EDGE TO RECEIVE NEW RAIL. LINE ITEM INCLUDES SUPPLEMENTAL REBAR. Est. 3,380 LF or 1,690 CF ESTIMATED. READY MIX CONCRETE.	1,690		CF	\$ 358.00	\$ 605,020.00
	CR-02 TYP SMALL	CONCRETE REPAIR BALCONY REPLACEMENT FULL DEPTH TYPICAL SMALL BALCONY INCLUDES NEW REBAR. EACH SMALL BALCONY IS APPROX. 35 CF (DOES NOT INCLUDE SLAB EDGE. PRICED ELSEWHERE FOR RAILS) 12 TIMES 37CF. READY MIX CONCRETE.					
	CR-03 TYP. MEDIUM	CONCRETE REPAIR BALCONY REPLACEMENT FULL DEPTH TYPICAL MEDIUM BALCONY INCLUDES NEW REBAR. EACH MEDIUM BALCONY IS APPROX. 57 CF (DOES NOT INCLUDE SLAB EDGE. PRICED ELSEWHERE FOR RAILS) ESTIMATE INCLUDES 6. READY MIX CONCRETE.	1,280		CF	\$ 406.00	\$ 519,680.00
	CR-04 TYP. CORNER	CONCRETE REPAIR BALCONY REPLACEMENT FULL DEPTH TYPICAL CORNER BALCONY INCLUDES NEW REBAR. 87 CF (DOES NOT INCLUDE SLAB EDGE. PRICED ELSEWHERE FOR RAILS). ESTIMATE INCLUDES 6. READY MIX CONCRETE.					
		BAG MIX CONCRETE REPAIRS					
	CR-05	MISC. CONCRETE REPAIR (ANY VOLUME "FULL DEPTH, PARTIAL DEPTH, COLUMN, WINDOW HEADS, WINDOW SILLS) ARE CONSOLIDATED INTO THIS LINE ITEM. TO BE MEASURED WITH ENGINEER AND CONTRACTOR. BAG MIX CONCRETE.	750		CF	\$ 446.50	\$ 334,875.00

Contractor is solely responsible for estimating quantities of all items listed as Lump Sum

SECTION 00300 - BID FORM
 BASE BID UNIT PRICES AND BID AMOUNTS
 OXFORD TOWERS ajustadoXboardJN 26jun20 Oxf
 BID FORM REVISION 1

	Item No.	Description	ADJUSTED QUANTITY	Bid Quantity [A1]	Unit	UNIT PRICE WORK		
						Unit Price [B1]	Bid Amount [A1 x B1]	
Concrete Repairs	CR-08A	STRUCTURAL CRACKS wider than 1/4". Epoxy inject cracks in structural concrete (with SIKADUR 31 HI-MOD GEL Cap Seal and SIKADUR 35, HI-MOD LV Epoxy Resin). Repairs per details and specifications.	50	100	LF	\$ 78.00	\$ 3,900.00	
	CR-08B	STRUCTURAL CRACKS wider than .004" and less than 1/4". Epoxy inject cracks in structural concrete (with SIKADUR 31 HI-MOD GEL Cap Seal and SIKADUR 35, HI-MOD LV Epoxy Resin). Repairs per details and specifications.	50	100	LF	\$ 78.00	\$ 3,900.00	
	CR-09	METAL INCLUSIONS :Misc. corroded foreign ferrous metal objects to be removed and replaced in accordance with ICRI guidelines, details and specifications. Shutter anchors removal included on line item TB-04	1,000	1,000	EA	\$ 25.00	\$ 25,000.00	
	CR-10A	WINDOW SILL REPLACEMENT (Type B/D) - Precast window sill 4"by 8" removal. Sill extends 4-inches past window opening on both sides. Consider a 75-inch wide window. Includes removal and reinstallation of window. Owner must provide window's information and NOA, and evidence of permitting records. (THE PUT BACK CONCRETE IS PART OF CR-05 PER MEASUREMENT. THE STUCCO IS PER THE VERTICAL MEASURE ST-01.)	40	80	EA	\$ 1,350.00	\$ 54,000.00	
	CR-10B	WINDOW SILL REPLACEMENT (Type A) - Precast window sill 4"by 8" removal . Sill extends 4-inches past window opening on both sides. Consider a 75-inch wide window. Includes removal and reinstallation of window. Owner must provide window's information and NOA, and evidence of permitting records. (THE PUT BACK CONCRETE IS PART OF CR-05 PER MEASUREMENT. THE STUCCO IS PER THE VERTICAL MEASURE ST-01.)	10	10	EA	\$ 1,350.00	\$ 13,500.00	
	CR-10C	WINDOW SILL REPLACEMENT (Type C) - Precast window sill 4"by 8" removal. Sill extends 4-inches past window opening on both sides. Consider a 25-inch wide window. Includes removal and reinstallation of window. Owner must provide window's information and NOA, and evidence of permitting records. (THE PUT BACK CONCRETE IS PART OF CR-05 PER MEASUREMENT. THE STUCCO IS PER THE VERTICAL MEASURE ST-01.)	4	4	EA	\$ 850.00	\$ 3,400.00	
	CR-11	CONCRETE TESTING: Provide third party concrete core testing for chlorides content and compression strength.	20	20	EA	\$ 1,200.00	\$ 24,000.00	
	CR-12	BREEZE WALL REPLACEMENT: Replace deteriorated breeze wall, to match existing. Include cementitious waterproofing on entire opening, with 8 inches return to the inside and outside walls. Consider each opening of 28x90 inches, or 28 pieces per opening.	5	5	EA	\$ 3,900.00	\$ 19,500.00	
CR	Subtotal - Concrete Repairs						\$	1,606,775.00

Contractor is solely responsible for estimating quantities of all items listed as Lump Sum

**SECTION 00300 - BID FORM
 BASE BID UNIT PRICES AND BID AMOUNTS
 OXFORD TOWERS ajustadoXboardJN 26jun20 Oxf
 BID FORM REVISION 1**

Stucco Repairs INCLUDED CEMENTITIOUS MEMBRANE	ST-01	WINDOWS SILL STUCCO REMOVAL - Remove and dispose of 12 inches stucco underneath of all windows extending 6 inches on each side. Install a reinforced cementitious membrane and install with two-coat wall stucco in accordance with ASTM C926 and TT's details/specifications. Includes all stucco accessories. This is two coat stucco system. Area under windows approx.	SAME AS VERTICAL STUCCO ST03-A	N/A	N/A	N/A	N/A
	ST-02	OVERHEAD SOFFIT STUCCO: Contractor shall remove and dispose of delaminated and/or damaged overhead soffit stucco. Contractor shall replace one-lift soffit stucco in accord with ASTM C926 and details/specifications. StoQuick Gold Soffit System preferred. NOTE: INCLUDED TWO (2) COAT CEMENTITIOUS WATERPROOFING SIKA 107		2,750	SF	\$ 36.50	\$ 100,375.00
	ST-03A	VERTICAL STUCCO: Contractor shall remove and dispose of delaminated and/or damaged vertical stucco on the tower envelope and balconies. Contractor shall replace two-lift wall stucco in accord with ASTM C926, details and specifications. This is a two coat stucco. NOTE: INCLUDED TWO (2) COAT CEMENTITIOUS WATERPROOFING SIKA 107		8,350	SF	\$ 36.50	\$ 304,775.00
	ST-03B	VERTICAL STUCCO WITH BUILDOUT: Contractor shall remove and dispose of delaminated and/or damaged vertical wall stucco on the tower envelope and balconies. Contractor shall buildout and plumb misaligned substrate (assume 1" thickness) to ensure stucco thickness does not exceed 5/8" section 039250. Contractor to replace two-lift wall stucco in accord with ASTM C926, details and specifications.		1,670	SF	\$ 42.00	\$ 70,140.00
	ST-04	SUBSTRATE JOINTS: Contractor shall install 8" wide plastic lath strips at all joints of dissimilar materials in accord with ASTM C926, details and specifications. Contractor to include tuck pointing and stainless steel fasteners.		3,375	LF	\$ 21.00	\$ 70,875.00
	ST-05	PARAPET RIBBON WALL: Contractor to install Sto RFP mesh stucco system on parapet exterior wall ribbon and underside ceiling in accord with ASTM C926. Include Sto Prime. Include stucco. NOTE: INCLUDED TWO (2) COAT CEMENTITIOUS WATERPROOFING SIKA 107		3,500	SF	\$ 36.50	\$ 127,750.00
	ST	Subtotal - Stucco Repairs					
Masonry Details	MR-01	MASONRY TUCK-POINTING REPAIRS: Repair deteriorated masonry components in accordance with TMS/ICRI guidelines, details and specifications. Work to include tuck-point between masonry runs, and at masonry/concrete transitions		750	LF	\$ 12.00	\$ 9,000.00
	MR-02	MASONRY FACE REPAIRS: Repair deteriorated masonry components in accordance with TMS/ICRI guidelines, details and specifications. Work to include gel patching of block face. Consider a blocks' cell width of 8 inches.		100	EA	\$ 43.00	\$ 4,300.00
	MR-03	MASONRY FILLED CELLS REPAIRS: Repair deteriorated masonry components in accordance with TMS/ICRI guidelines, details and specifications. Work to include replacement of deteriorated/missing steel, coating of exposed steel, surface prep, saw cutting, and grouting of empty cells. Consider a blocks' cell width of 8 inches.		100	EA	\$ 120.00	\$ 12,000.00
Metal/ Fire Doors	MD	FIRE DOORS: Contractor shall install with a sub contractor 54 doors with 55 leafs. See signed sealed Door drawings		54 doors/55 leafs	LS	\$ 1.00	\$ 153,900.00
MR	Subtotal - Masonry Repairs						\$ 179,200.00
Base Bid Unit Price Total							\$ 4,411,971.75

Contractor is solely responsible for estimating quantities of all items listed as Lump Sum

SECTION 00300 - BID FORM
 BASE BID UNIT PRICES AND BID AMOUNTS
 OXFORD TOWERS ajustadoXboardJN 26jun20 Oxf
 BID FORM REVISION 1

BID COST SUMMARY

GENERAL CONDITIONS	\$	411,200.00
LUMP SUM COST	\$	1,460,001.75
UNIT PRICE COST	\$	2,540,770.00
DOOR COST	\$	-
TOTAL PRICE	\$	4,411,971.75

HURRICANES AND NAMED STORMS

	ITEM NO.	DESCRIPTION	Bid Quantity	PRICE	Unit
HURRICANES	H1	Hurricane Demobilization/Mobilization - Provide itemization of costs.	Each Occurrence	\$ 15,000.00	LS
	H2	Hurricane Demobilization - Provide estimated duration to demobilize the site in preparation for a hurricane.		TBD	DAYS
	H3	Hurricane ReMobilization - Provide estimated duration to remobilize the site.		TBD	DAYS

CONTRACT TIME DURATION	280	CALENDAR DAYS
Time/Material/Equipment Cost Plus	25	%

* **NOTE:** Any deviations from specified products must be specifically stated in the bid
 ** **NOTE:** Contractor to create mock-ups and receive written approval architect / engineer prior to the purchasing of materials for scope of work

Contractor is solely responsible for estimating quantities of all items listed as Lump Sum



CERTIFICATE OF LIABILITY INSURANCE

DATE (MM/DD/YYYY)
9/13/2024

THIS CERTIFICATE IS ISSUED AS A MATTER OF INFORMATION ONLY AND CONFERS NO RIGHTS UPON THE CERTIFICATE HOLDER. THIS CERTIFICATE DOES NOT AFFIRMATIVELY OR NEGATIVELY AMEND, EXTEND OR ALTER THE COVERAGE AFFORDED BY THE POLICIES BELOW. THIS CERTIFICATE OF INSURANCE DOES NOT CONSTITUTE A CONTRACT BETWEEN THE ISSUING INSURER(S), AUTHORIZED REPRESENTATIVE OR PRODUCER, AND THE CERTIFICATE HOLDER.

IMPORTANT: If the certificate holder is an ADDITIONAL INSURED, the policy(ies) must have ADDITIONAL INSURED provisions or be endorsed. If SUBROGATION IS WAIVED, subject to the terms and conditions of the policy, certain policies may require an endorsement. A statement on this certificate does not confer rights to the certificate holder in lieu of such endorsement(s).

PRODUCER Construction Casualty Insurance, LLC 3637 4th Street North Suite 310 Saint Petersburg, FL 33704	CONTACT NAME: Certificates PHONE (A/C, No, Ext): (727) 258-5774 FAX (A/C, No): E-MAIL ADDRESS: certs@cci-ins.com	
	INSURER(S) AFFORDING COVERAGE	
INSURED Florida's Choice Painting, Inc. DBA Florida's Choice Contracting 2121 Fillmore Street Hollywood, FL 33020	INSURER A : Security National Insurance Company NAIC # 33120	
	INSURER B : Ascendant Commercial Insurance 13683	
	INSURER C : Frank Winston Crum Insurance Company 11600	
	INSURER D : AGCS Marine Insurance Company 22837	
	INSURER E :	
	INSURER F :	

COVERAGES **CERTIFICATE NUMBER:** **REVISION NUMBER:**

THIS IS TO CERTIFY THAT THE POLICIES OF INSURANCE LISTED BELOW HAVE BEEN ISSUED TO THE INSURED NAMED ABOVE FOR THE POLICY PERIOD INDICATED. NOTWITHSTANDING ANY REQUIREMENT, TERM OR CONDITION OF ANY CONTRACT OR OTHER DOCUMENT WITH RESPECT TO WHICH THIS CERTIFICATE MAY BE ISSUED OR MAY PERTAIN, THE INSURANCE AFFORDED BY THE POLICIES DESCRIBED HEREIN IS SUBJECT TO ALL THE TERMS, EXCLUSIONS AND CONDITIONS OF SUCH POLICIES. LIMITS SHOWN MAY HAVE BEEN REDUCED BY PAID CLAIMS.

INSR LTR	TYPE OF INSURANCE	ADDL INSD	SUBR WVD	POLICY NUMBER	POLICY EFF (MM/DD/YYYY)	POLICY EXP (MM/DD/YYYY)	LIMITS
A	<input checked="" type="checkbox"/> COMMERCIAL GENERAL LIABILITY <input type="checkbox"/> CLAIMS-MADE <input checked="" type="checkbox"/> OCCUR GEN'L AGGREGATE LIMIT APPLIES PER: <input type="checkbox"/> POLICY <input checked="" type="checkbox"/> PROJECT <input type="checkbox"/> LOC OTHER:	X	X	SES181491500	4/13/2024	4/13/2025	EACH OCCURRENCE \$ 1,000,000 DAMAGE TO RENTED PREMISES (Ea occurrence) \$ 100,000 MED EXP (Any one person) \$ PERSONAL & ADV INJURY \$ 1,000,000 GENERAL AGGREGATE \$ 2,000,000 PRODUCTS - COMP/OP AGG \$ 2,000,000
B	AUTOMOBILE LIABILITY <input type="checkbox"/> ANY AUTO OWNED AUTOS ONLY <input checked="" type="checkbox"/> SCHEDULED AUTOS <input checked="" type="checkbox"/> HIRED AUTOS ONLY <input checked="" type="checkbox"/> NON-OWNED AUTOS ONLY			CA-59961-1	4/8/2024	4/8/2025	COMBINED SINGLE LIMIT (Ea accident) \$ 1,000,000 BODILY INJURY (Per person) \$ BODILY INJURY (Per accident) \$ PROPERTY DAMAGE (Per accident) \$
A	<input checked="" type="checkbox"/> UMBRELLA LIAB <input checked="" type="checkbox"/> OCCUR <input checked="" type="checkbox"/> EXCESS LIAB <input type="checkbox"/> CLAIMS-MADE DED RETENTION \$	X	X	EXS180967900	4/13/2024	4/13/2025	EACH OCCURRENCE \$ 2,000,000 AGGREGATE \$ 2,000,000
C	WORKERS COMPENSATION AND EMPLOYERS' LIABILITY ANY PROPRIETOR/PARTNER/EXECUTIVE OFFICER/MEMBER EXCLUDED? (Mandatory in NH) <input type="checkbox"/> Y <input checked="" type="checkbox"/> N If yes, describe under DESCRIPTION OF OPERATIONS below	N/A	X	FWFL0025307602	4/13/2024	4/13/2025	<input checked="" type="checkbox"/> PER STATUTE <input type="checkbox"/> OTH-ER E.L. EACH ACCIDENT \$ 1,000,000 E.L. DISEASE - EA EMPLOYEE \$ 1,000,000 E.L. DISEASE - POLICY LIMIT \$ 1,000,000
D	Equipment Floater			MXI9307982421986	5/22/2024	5/22/2025	See Remarks

DESCRIPTION OF OPERATIONS / LOCATIONS / VEHICLES (ACORD 101, Additional Remarks Schedule, may be attached if more space is required)
Concrete, Painting, and Waterproofing Contractor
 When required by written contract, the certificate holder is listed as an additional insured on a primary non-contributory basis, with regard to the General Liability policy. A waiver of subrogation applies in favor of the certificate holder on the General Liability and Workers' Compensation policies. Umbrella policy is follow form.

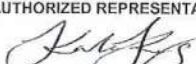
CERTIFICATE HOLDER Hollywood CRA 1948 Harrison Street Hollywood, FL 33020	CANCELLATION SHOULD ANY OF THE ABOVE DESCRIBED POLICIES BE CANCELLED BEFORE THE EXPIRATION DATE THEREOF, NOTICE WILL BE DELIVERED IN ACCORDANCE WITH THE POLICY PROVISIONS. AUTHORIZED REPRESENTATIVE 
---	--

THIS ENDORSEMENT CHANGES THE POLICY. PLEASE READ IT CAREFULLY.

**ADDITIONAL INSURED – OWNERS, LESSEES OR
CONTRACTORS – SCHEDULED PERSON OR
ORGANIZATION**

This endorsement modifies insurance provided under the following:

COMMERCIAL GENERAL LIABILITY COVERAGE PART

SCHEDULE

Name Of Additional Insured Person(s) Or Organization(s):	Location(s) Of Covered Operations
All persons or organizations where required by written contract with the Named Insured.	All locations where the Named Insured is performing operations on behalf of the designated additional insured.
Information required to complete this Schedule, if not shown above, will be shown in the Declarations.	

A. Section II – Who Is An Insured is amended to include as an additional insured the person(s) or organization(s) shown in the Schedule, but only with respect to liability for "bodily injury", "property damage" or "personal and advertising injury" caused, in whole or in part, by:

1. Your acts or omissions; or
2. The acts or omissions of those acting on your behalf;

in the performance of your ongoing operations for the additional insured(s) at the location(s) designated above.

B. With respect to the insurance afforded to these additional insureds, the following additional exclusions apply:

This insurance does not apply to "bodily injury" or "property damage" occurring after:

1. All work, including materials, parts or equipment furnished in connection with such work, on the project (other than service, maintenance or repairs) to be performed by or on behalf of the additional insured(s) at the location of the covered operations has been completed; or
2. That portion of "your work" out of which the injury or damage arises has been put to its intended use by any person or organization other than another contractor or subcontractor engaged in performing operations for a principal as a part of the same project.

THIS ENDORSEMENT CHANGES THE POLICY. PLEASE READ IT CAREFULLY.

**ADDITIONAL INSURED – OWNERS, LESSEES OR
CONTRACTORS – COMPLETED OPERATIONS**

This endorsement modifies insurance provided under the following:

COMMERCIAL GENERAL LIABILITY COVERAGE PART

SCHEDULE

Name of Additional Insured Person(s) or Organization(s):	Location and Description of Completed Operations
All persons or organizations where written contract with the Named Insured requires additional insured completed operations coverage. This form does not apply to your work on "residential property".	All locations where the Named Insured is performing operations on behalf of the designated additional insured.
Information required to complete this Schedule, if not shown above, will be shown in the Declarations.	

Section II – Who Is An Insured is amended to include as an additional insured the person(s) or organization(s) shown in the Schedule, but only with respect to liability for "bodily injury" or "property damage" caused, in whole or in part, by "your work" at the location designated and described in the schedule of this endorsement performed for that additional insured and included in the "products-completed operations hazard".

K & I ELECTRIC INC
 3815 NW 125 ST
 OPA-LOCKA FL 33054

Estimate

Date	Estimate #
7/10/2024	955

Name / Address
AMERICAN MANNYEMENT BARBARA MUNOS 10631 NORTH KENDAL DR #1205 MIAMI FL 33176

			Project
Description	Qty	Rate	Total
JOB NAME :OXFORD TOWER.			
INSTALLATION OF NEW BALCONY LIGHT FIXTURE ON WALL OUT SIDE OF EACH BALCONY WITH ITS OWN SWITCH TO CONTROL LIGHT FIXTURE WILL INCLUDE WALL REPAIR (PLASTER) AND ,MISCELLANEOUS MATERIAL	124	225.00	27,900.00
LIGHTING FIXTURE AMBER LAMP WALL MOUNT LABOR INCLUDED TYPE (JDG)	124	142.32	17,647.68
LIGHTING FIXTURE WALL MOUNT LANTERN WITH AMBER LAMP LABOR INCLUDED	6	345.23	2,071.38
LIGHTING FIXTURE POST MOUNT LANTERN WITH AMBER LAMP LABOR INCLUDED	6	345.23	2,071.38
LIGHTING WALL PACK ON NORTH SIDE PARKING AMBER LABOR INCLUDED	4	425.56	1,702.24
LUMINAIRE SIGN AND TOWER BUILDING NUMBER ON OUT SIDE OF BUILDING NEON 12"X10'	1	6,050.00	6,050.00
NEON INSTALLATION AND ELECTRICAL WORK	1	1,500.00	1,500.00
		Total	\$58,942.68



JUSTICE DESIGN GROUP

The Perfect Lighting Choice.™

Ceramic Large Cylinder Wall Sconce - Closed Top (Outdoor)



GLAZES (GROUP 1):



Matte White (MAT)

Lamping:

*Standard
Incon*

Standard Incandescent

Configured SKU: CER-1260W-MAT

Description :

Large Cylinder - Closed Top (Outdoor)

Primary Shade Material :

Ceramic

Frame Style :

Ambiance

Finish Groups :

Bisque, 1, 2, 4

UL/ETL Listing :

Suitable for Wet Locations

Feature :

Ceramic, Dark Sky, Made in USA, Outdoor, Turtle-Friendly

Standard Incandescent :

(1) 100W A-19 Max

Optional GU24 LED :

(1) 10W GU24 Self Ballast LED Max

Optional LED :

12W 1,000 Initial Lumens

Dimension :

12.5" H x 7.75" W x 6.25" Proj.

Mounting Center :

6.25"

Notes :

Made in the USA, This item is available in up to 40 hand-painted finishes, as well as unfinished ceramic bisque (BIS) which is paintable, Fixture is Dark Sky compliant and certified Turtle-Friendly

Justice Design Group, LLC.
Los Angeles, California

Telephone: (800) 533-4799 (213) 437-0102
Fax: (800) 533-2911 (213) 437-0860

Email: sales@JDG.com
Website: www.JDG.com



JUSTICE DESIGN GROUP

The Perfect Lighting Choice.™

Ceramic Cylinder Flush-Mount (Outdoor)



Bisque:



Bisque (BIS)

Lamping:

*Standard
Incan*

Standard Incandescent

Configured SKU: CER-6100W-BIS

Description :

Cylinder Flush-Mount (Outdoor)

Primary Shade Material :

Ceramic

Frame Style :

Radiance

Finish Groups :

Bisque, 1, 2, 4

UL/ETL Listing :

Suitable for Wet Locations

Feature :

Ceramic, Dark Sky, Made in USA, Outdoor, Turtle-Friendly

Standard Incandescent :

(1) 75W A-19 Max

Optional GU24 LED :

(1) 10W GU24 Self Ballast LED Max

Optional LED :

12W 1,000 Initial Lumens

Dimension :

8.5" H x 6.5" Dia.

Notes :

Made in the USA. This item is available in up to 40 hand-painted finishes, as well as unfinished ceramic bisque (BIS) which is paintable. Fixture has a natural Bisque (unfinished) interior. Fixture is Dark Sky compliant and certified Turtle-Friendly.

Justice Design Group, LLC.
Los Angeles, California

Telephone: (800) 533-4799 (213) 437-0102
Fax: (800) 533-2911 (213) 437-0860

Email: sales@JDG.com
Website: www.JDG.com

	ITEM #:	45000/1
	UPC	748119040912
	Description	Glendale 1-Light Outdoor Wall Lamp in Regal Bronze
	Finish	Regal Bronze
	Materials	Cast Aluminum
	Brand	ELK Lighting
	Collection	Glendale
	Category	Outdoor Lighting
	Type	Sconce

ITEM DIMENSIONS			RATINGS & SPECIFICATIONS				
Width	7 Inches		Safety Rating	N/A			
Depth	8 Inches		ADA Compliant	N/A			
Height	13 Inches		BULBS / SOCKETS				
Weight	2 pounds					Quantity	1
ADDITIONAL DIMENSIONS			Included	No	Type	A19 (E26 Medium Base)	
Backplate / Canopy	N/A		Other	N/A			
HCWO			CHAIN / CORD INFORMATION				
Min. Extension	N/A		Chain	N/A	Cord	N/A	
Max. Extension	N/A		SHADE / GLASS DETAILS				
OVERALL HEIGHT			Shade/Glass Description	Regal Bronze with Clear Glass			
Min.	N/A	Max.	N/A	Width	N/A	Height	N/A
EXTENSION ROD(S)			Width at Top	N/A	Width at Bottom	N/A	
N/A							

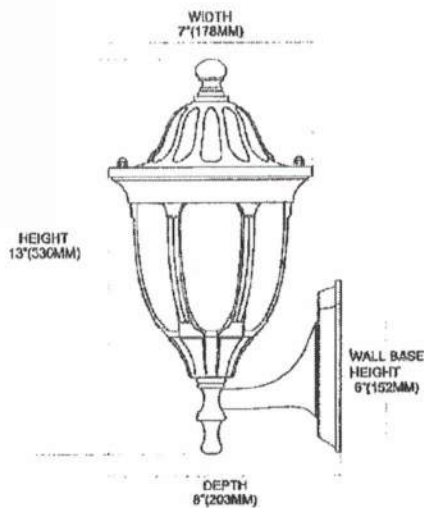

Rev. 5/9/2019



ITEM #:	45005/1
UPC	748119040943
Description	Glendale 1-Light Outdoor Post Mount in Regal Bronze
Finish	Regal Bronze
Materials	Glass, Metal
Brand	ELK Lighting
Collection	Glendale
Category	Outdoor Lighting
Type	Post Mount

ITEM DIMENSIONS				RATINGS & SPECIFICATIONS				
Width	9 inches			Safety Rating	N/A		Certification	N/A
Depth	9 inches			ADA Compliant	N/A		Voltage	N/A
Height	17 inches			BULBS / SOCKETS				
Weight	3 pounds							
ADDITIONAL DIMENSIONS				Included	No	Type	A19 (E26 Medium Base)	
Backplate / Canopy	N/A			Other	N/A			
HCWO	N/A			CHAIN / CORD INFORMATION				
Min. Extension	N/A			Chain	N/A		Cord	N/A
Max. Extension	N/A			SHADE / GLASS DETAILS				
OVERALL HEIGHT				Shade/Glass Description	Regal Bronze with Clear Glass			
Min.	N/A		Max.	N/A				
EXTENSION ROD(S)				Width	9 inches		Height	N/A
N/A				Width at Top	N/A		Width at Bottom	N/A

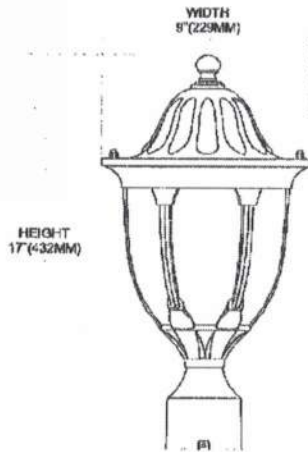

Rev. 5/9/2019

Project Name:	Part Number:	Type:
---------------	--------------	-------

FULL CUTOFF WALL PACK

OUTDOOR WALL MOUNT



407-478-3759
www.ilp-inc.com

FEATURES

- Architectural die-cast aluminum housing
- Factory Select Finishes: Bronze (BRZ), Black (BLK), Silver (SLV) & White (WHT)
- Custom colors finishes available
- Hinged full cutoff front frame for easy access to driver compartment
- Three 1/2" coin plugs on sides for conduit or electronic photocell
- Multiple optical distributions available: Type II, III, & IV
- Cast-in template for mounting directly over a 4" recessed outlet box
- 3000K, 4000K and 5000K CCT
- Bluetooth Programmable PIR Occupancy, Photocell, & Bi-Level Dimming Sensors Available
- 0-10V Dimmable Driver
- Dark Sky Compliant, 3000K is IDA Listed
- 120-277V Universal Voltage or 347-480V High Voltage
- Calculated L70>100,000 hrs @ 25°C per TM-21-11
- 5 Year Warranty (std); 10 Year Warranty Optional
- ETL Listed for Wet Location with IP66 Rated Optical Chamber
- DesignLights Consortium® Premium Qualified Luminaire



SUITABLE APPLICATIONS

- Parking Lots
- Loading Dock Areas
- Exterior Wall Lighting
- Building Entrance Ways

ORDERING GUIDE:

SERIES	LUMENS	DRIVER	CCT	OPTIC	FINISH	WARRANTY
<input type="checkbox"/> WPCS Full Cutoff Wall Pack	<input type="checkbox"/> 3L <input type="checkbox"/> 4L <input type="checkbox"/> 6L	<input type="checkbox"/> U 120-277V <input type="checkbox"/> HV 347-480V ^{4,7} <input type="checkbox"/> DD Dual Driver ³	<input type="checkbox"/> 50 <input type="checkbox"/> 40 <input type="checkbox"/> 30	<input type="checkbox"/> T2 <input type="checkbox"/> T3 <input type="checkbox"/> T4	<input type="checkbox"/> BLANK Bronze <input type="checkbox"/> BLK Black <input type="checkbox"/> SLV Silver <input type="checkbox"/> WHT White <input type="checkbox"/> CC Custom Color	<input type="checkbox"/> BLANK 5 Year <input type="checkbox"/> 10YR ^{5,9} 10 Year
<input type="checkbox"/> WPCM Full Cutoff Wall Pack	<input type="checkbox"/> 3L <input type="checkbox"/> 4L <input type="checkbox"/> 6L <input type="checkbox"/> 8L <input type="checkbox"/> 12L					

OPTIONS		CONTROLS	
Factory Installed		BASIC - Factory Installed	
<input type="checkbox"/> SP1 ^{1,2}	10KA Max Univolt Surge Protector	<input type="checkbox"/> FSP-311/LX ^{3,4}	Legrand FSP-311 120-277V Sensor (X = Mounting Height 2 = <8', 3=10-20')
<input type="checkbox"/> SP2 ^{3,4}	20KA Max Univolt Surge Protector		
<input type="checkbox"/> SP480V2	20KA Max 347-480V Surge Protector		
<input type="checkbox"/> FUSE/SXXX	Single-line Voltage Fuse (120, 277 or 347V)		
<input type="checkbox"/> FUSE/DXXX	Dual-line Voltage Fuse (208, 240 or 480V)		
<input type="checkbox"/> SMLxxxx	Specified Lumen Output (xxxx = lumen output)		
<input type="checkbox"/> EMS ⁵	5W LED Battery Backup (32°F-104°F)		
<input type="checkbox"/> EMS/HE ²	5W 120-277V/LED High Efficacy CEC Title 20 Battery Backup (32°F-104°F)		
<input type="checkbox"/> EM7 ^{1,2}	7W LED Battery Backup (32°F-104°F)		
<input type="checkbox"/> EM7/HE ^{2,3}	7W 120-277V/LED High Efficacy CEC Title 20 Battery Backup (32°F-104°F)		
<input type="checkbox"/> EM10 ²	10W LED CEC Title 20 Battery Backup (32°F-104°F)		
<input type="checkbox"/> EM10/HE ²	10W 120-277V LED High Efficacy CEC Title 20 Battery Backup (32°F-104°F)		
<input type="checkbox"/> EM10/HE/SD ²	10W 120-277V Self Diagnostic High Efficacy CEC Title 20 Battery Backup		
<input type="checkbox"/> EM12 ^{2,3}	12W LED Battery Backup (32°F-104°F)		
<input type="checkbox"/> EMCT6 ⁴	6W Cold Temp Battery Backup -40°F (-40°C)		
<input type="checkbox"/> EMCT8 ⁴	8W Cold Temp Battery Backup -22°F (-30°C)		
<input type="checkbox"/> EMCT14 ⁴	14W Cold Temp Battery Backup -4°F (-20°C)		
Ship with Accessories		Ship with Accessories	
<input type="checkbox"/> WPC15WG ¹⁰	Wire Guard (WPCS) Not available with Glare Shield	<input type="checkbox"/> PCU ⁹	Electronic UNIV Photocell (120-277V)
<input type="checkbox"/> WPC25WG ²	Wire Guard (Not available with Glare Shield)		
<input type="checkbox"/> GSWPCS ¹⁰	3-Sided Glare Shield (WPCS)		
<input type="checkbox"/> GSWPCM ²	3-Sided Glare Shield (WPCM)		

¹ Does not qualify for DLC
² Not available with HV option
³ WPCM Only
⁴ Not compatible with 3L Model

⁵ SP1/SP2 specified in combination w/ battery backup, separate surge protectors are required per electrical code
⁶ Requires bluetooth enabled device for programming (provided by others)
⁷ Not available with FSP-311 or ZLD12

⁸ Contact Factory for more details
⁹ Requires additional surge protection (SP1, SP2, SP480V2). For additional details see general terms and conditions
¹⁰ WPCS Only

FULL CUTOFF WALL PACK

OUTDOOR WALL MOUNT

LED SYSTEMS INFO		3000K		4000K		5000K		BUG Rating	Watts ²
Part Numbers	Distribution	Lumens	Efficacy	Lumens	Efficacy	Lumens	Efficacy		
WPCS-3L	T2	3466	156	3282	149	3438	156	B1-U0-G1	22
	T3	3448	155	3263	148	3418	155	B1-U0-G1	
	T4	3322	149	3209	146	3350	152	B1-U0-G1	
WPCS-4L	T2	4521	146	4367	142	4566	149	B2-U0-G2	31
	T3	4494	145	4340	141	4537	148	B1-U0-G1	
	T4	4412	142	4261	139	4457	145	B1-U0-G1	
WPCS-5L	T2	6039	139	5890	137	6161	137	B2-U0-G2	45
	T3	6002	138	5855	130	6124	136	B2-U0-G2	
	T4	5883	135	5748	128	6012	134	B1-U0-G2	
WPCM-3L	T2	3557	167	3456	162	3615	169	B1-U0-G1	21
	T3	3536	166	3435	161	3593	168	B1-U0-G1	
	T4	3471	163	3373	158	3528	165	B1-U0-G1	
WPCM-4L	T2	4414	167	4148	159	4392	166	B1-U0-G1	26
	T3	4387	166	4123	158	4312	165	B1-U0-G1	
	T4	4307	163	4047	155	4294	162	B1-U0-G1	
WPCM-6L	T2	6018	153	5994	151	6270	158	B2-U0-G2	40
	T3	5981	152	5958	150	6232	157	B2-U0-G2	
	T4	5872	149	5849	148	6118	154	B1-U0-G2	
WPCM-8L	T2	8220	144	8166	143	8542	150	B2-U0-G2	57
	T3	8171	143	8117	142	8490	149	B2-U0-G2	
	T4	8021	141	7962	140	8325	146	B2-U0-G2	
WPCM-12L	T2	12554	144	11571	133	12103	139	B3-U0-G3	87
	T3	12478	143	11501	133	12030	139	B2-U0-G2	
	T4	12250	140	11291	130	11810	136	B2-U0-G2	

¹ LED Chips are frequently updated therefore values are nominal ² Electrical data at 25C (77F). Actual wattage may differ by +/-10%

ELECTRICAL DATA (AMPS)¹

Lumen Package	Wattage	120V	208V	240V	277V	347V	480V
WPCS-3L	22	0.18	0.11	0.09	0.08	N/A	N/A
WPCS-4L	31	0.26	0.15	0.13	0.11	0.09	0.06
WPCS-5L	45	0.38	0.22	0.19	0.16	0.13	0.09
WPCM-3L	21	0.18	0.10	0.09	0.08	N/A	N/A
WPCM-4L	26	0.22	0.13	0.11	0.09	0.07	0.05
WPCM-6L	40	0.33	0.19	0.17	0.14	0.12	0.08
WPCM-8L	57	0.48	0.27	0.24	0.21	0.16	0.12
WPCM-12L	87	0.73	0.42	0.36	0.31	0.25	0.18

¹ Electrical data at 25C (77F). Actual wattage may differ by +/-10%

FULL CUTOFF WALL PACK

OUTDOOR WALL MOUNT

SPECIFICATIONS

CONSTRUCTION

The Full Cutoff Wall Pack series features both a small and medium scale, manufactured in an architectural die-cast aluminum construction. The WPC is protected with a durable Bronze polyester powder coat finish to withstand extreme weather changes without cracking or peeling with optional wet paint Black, White, and Silver finishes (Consult factory for availability of alternate finishes). The recessed LED source allows for a full cutoff designation with no uplight and complies with IDA in 3000K CCT. The fully gasketed housing is wet location rated with the optical chamber meeting an IP66 rating for ingress protection against moisture and environmental contaminants. One-piece silicone gasket seals door and back box. Salt Spray tested for 500 hrs.

ELECTRICAL

High-performance driver features over-voltage, under-voltage, short circuit and over temperature protection. 0-10V dimming (10% - 100%) standard. Standard Universal Voltage (120-277 Vac) Input 50/60 Hz or optional High Voltage (347-480 Vac). L70 >100,000 hrs. in accordance of IESNA TM-21-11 Projected values at 25°C Ambient temperature. Total harmonic distortion: 0.90. Input power stays constant over life. Minimum 4kV surge rating. Additional protection is available in 10kV and 20kV options. Optional 120-277V battery backup & cold weather battery options provide 90 minutes of constant power to the LED system, ensuring code compliance. Select models CEC title 20 Compliant, see ordering guide.

INSTALLATION

The WPC Wall Pack is designed for effortless installation to standard 3-1/2" to 4" round/octagonal, 4" square, single gang, masonry junction boxes or vertical surface mounting (secured by lag bolts (supplied by others)). 1/2" NPT conduit entry points allow for surface conduit or thru-branch wiring. Back box is an authorized electrical wiring compartment.

OPTICS

The isolated IP66 rated silicone gasket sealed optical chamber utilizes impact resistant and UV stabilized polycarbonate optics to provide exceptional coverage in IES types T2, T3, T4 distributions. Available in 3000K, 4000K, & 5000K color temperatures per ANSI C78.377. Minimum CRI of 70. The WPC Series produces Zero uplight and is IDA listed in 3000K color temperature.

THERMAL

The WPC Series features an array of High-efficacy LED's mounted on a metal core circuit board. The LED boards are mounted directly to the cast aluminum housing with heat dissipating fins to provide excellent thermal performance extending the life of electronic components. Operating Ambient Temperature: -40°C to +50°C (-40°F to 122°F). Operating temperature for standard battery backup: 0°C to +45°C (+32°F to +113°F). EMCT10: -20°C to +45°C; EMCT8: -30°C to +40°C; EMCT6: -40°C to +35°C.

CONTROLS

Standalone Controls:

Three 1/2" NPT apertures allow for field or factory installed 120-277V universal electronic photocell. Optional PIR sensors available installed in the rear housing. Sensors provide optional on/off control, photocell capability, bi-level dimming, high-end trim, and bluetooth configuration allows for on-site modifications. See page x for more details.

Wireless Control Systems:

The WPC Series is wireless mesh controls ready with Synapse wireless control platform. Available with and without PIR sensors. Inquire with factory for more information or for additional controls options, including customer supplied items.

CERTIFICATIONS

ETL Listed for wet locations. IP66 Rated Optical Chamber per IEC 60598. Tested in accordance with IESNA LM-79 and LM-80 standards. BAA compliant. RoHS Compliant. Title 24 Compliant; see local ordinance for qualification information.

WARRANTY

5 Year Warranty Standard; 10 Year Warranty Optional (Terms and Conditions apply).

FULL CUTOFF WALL PACK

OUTDOOR WALL MOUNT

LINE DRAWING

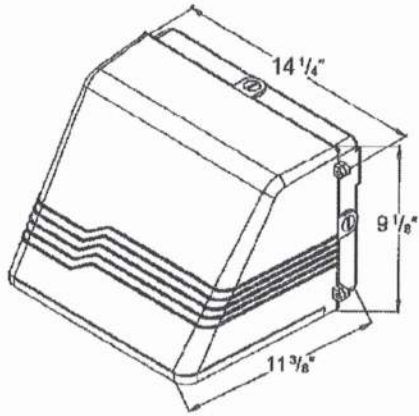

WPCS

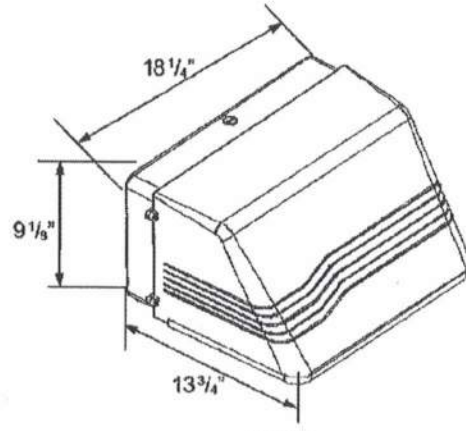

WPCM

SECURITY OPTIONS

WPCxWG - Wire Guard, SS Construction

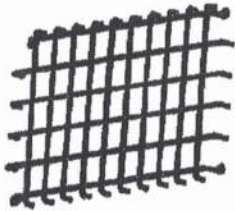

FWC SEA TURTLE LIGHTING GUIDELINES

These guidelines provide general information for all property owners living adjacent to sea turtle nesting beaches, but they are specifically designed to help property owners required to avoid and minimize lighting impacts to sea turtles as part of the State permitting programs, such as Coastal Construction Control Line (CCCL) permits and Environmental Resource Permits (ERP). In the permitting process, property owners must minimize all lights that may be visible from the beach, including all exterior, structural, decorative, and landscape lighting. This includes interior light visible through glass windows, doors and walls (either facing or perpendicular to the beach) as well as light from pools, fire pits, electronic devices such as televisions, tiki torches, etc.

FWC recommends beachfront property owners follow the three golden rules, "Low-Shielded-Long" when installing or modifying lights. All three must be used in combination to be effective, as they are all equally important!

KEEP IT LOW

- Fixtures must be mounted as **low as possible** to achieve required light levels.
- Bulbs must produce the **lowest wattage/lumens** necessary for the needed purpose.

KEEP IT SHIELDED

- Fixtures must be completely downward-directed.
- Fixtures must shield the bulb, lamp, or glowing lens from the beach.

BAD EXAMPLE: Unshielded bulb



GOOD EXAMPLE: Shielded bulb with Amber LED (long-wavelength, 560 nm or higher)

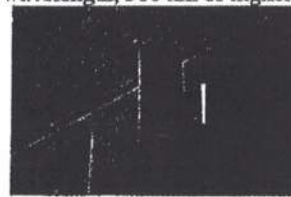

KEEP IT LONG

- Lamp/Bulb must produce only **long wavelength light** (560 nm or greater, which is amber, orange, or red)
 - **The Best Current Technology:** Red LED, Orange LED, Amber LED, Low Pressure Sodium (LPS)
 - Please note, phosphorus converted bulbs, such as PC amber bulbs are not true long wavelength light sources, since there are wavelength readings below 560 nm.

BAD: Incandescent bulb

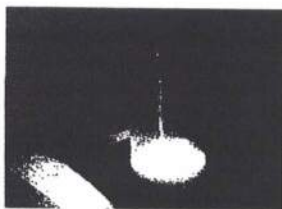

GOOD: Amber Bulb (long-wavelength, 560nm or higher)



Acceptable Fixtures

All exterior lights proposed for the seaward or shore perpendicular side of the structure should be well-shielded, full cut-off, downward directed fixtures with a long-wavelength light source (wavelength readings of 560 nanometers (nm) or higher).

If the exterior fixtures on the landward side of the structure are **not** visible directly or indirectly from the beach, they are only required to be downward directed.

How effective are full cut-off fixtures?

Below, look at an unshielded fixture and a full cut-off fixture side-by-side. The acorn light on the left wastes about 60% of the light into the sky. The one on the right is a full-cut off fixture with a recessed bulb, which provides more light on the ground. This is a good example of how full-cut off fixtures are not only good for sea turtles, but also for human safety because they direct light where it is needed, on the ground. To make the full cut-off example even better, it should be fitted with a shield that blocks light on the beachside and a long-wavelength lamp/bulb.



Acceptable Lamps / Bulbs

All fixtures visible from the beach should have a long-wavelength lamp – a bulb that looks amber or red because it only produces light with wavelengths of 560 nm or higher. White light such as metal halide, halogen, fluorescent, mercury vapor and incandescent lamps can disorient nesting sea turtles and their hatchlings, leading them away from the water. The following fixtures will minimize – but not totally remove – the risk of disorientation if properly installed in a well shielded, downward directed fixture.

- Low Pressure Sodium (LPS): 18W, 35W
- Red, Orange or Amber LED (true red, orange or amber diodes, NOT FILTERS)
- True red neon
- Other light sources that produce light of 560 nm or greater

HINT: LEDs tend to be much brighter than incandescent bulbs, so be sure not to over light an area!

Upon review and approval by FWC, use of shorter wavelength lights may be allowed in limited areas where direct and indirect light or glow would not be visible from the beach.

A list of the Florida Fish and Wildlife Conservation Commission's Certified Wildlife Lighting, which includes acceptable lamps/bulbs for fixtures, can be found [here](#).

How can I tell if it is a long-wavelength light source?

Specifications for the wavelength is available from the manufacturer. Specifically, you can request a spectral distribution graph, as seen below.

The graph on the left displays an **acceptable** wavelength reading for a long-wavelength light source (i.e. amber lamp), with wavelength readings above 560 nm or higher. The graph on the right displays an **unacceptable** wavelength reading, with wavelength readings below the 560 nm cutoff.

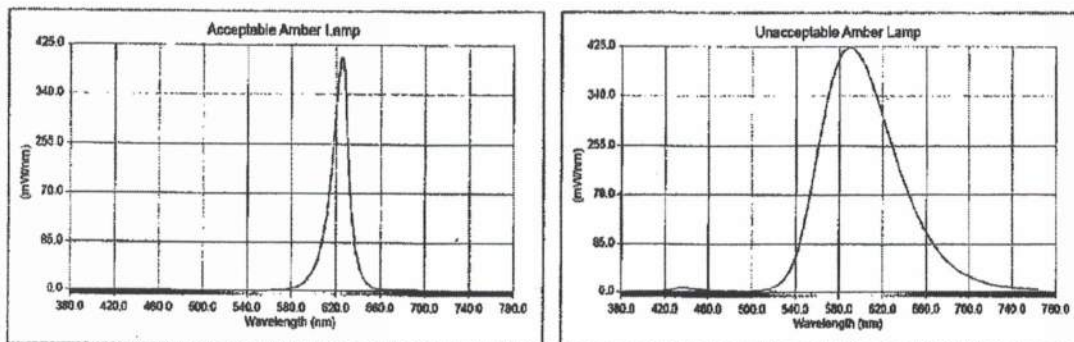

Minimizing Light

Even though a fixture/lamp combination may be Low-Shielded-Long, too many fixtures may still result in sea turtles becoming disoriented. In addition to the lowest wattage necessary for safety, light can also be minimized by installing fewer fixtures.

- Use the lowest wattage necessary.
- Use a minimal number of fixtures.
- Use only if needed for safety.

Why do I need to minimize long-wavelength light?

A common misconception is that long-wavelength lighting (i.e. LPS, Red, Orange or Amber LEDs) is not visible to sea turtles. This is FALSE. Long-wavelength lighting is less disruptive than white light, but even long-wavelength lighting that is too bright may cause impacts to sea turtles and their hatchlings! Therefore, we recommend only utilizing lights that may be visible from the beach if there are state or federal requirements for specific light levels to ensure public safety (such as stairs or egress/ingress walkways).

We **do not recommend** the following types of lighting, since they are not needed for safety:

- Private balcony lights
- Pond lights
- Tree Strap Downlights
- Fountain lights on seaward or shore perpendicular side of a structure
- Up lights
- Dune Walk over lights
- Decorative Lighting



Impacts from interior lighting

State rules require that tinted glass or film with a visible light transmittance value of forty-five (45) percent or less (inside to outside) must be used on all glass windows, doors and walls within line of sight of the beach, usually the seaward and shore-perpendicular sides of the structure. However, since those rules were passed, there are now better options because of advances in tinting and more information on sea turtle disorientations. Window tints/film with transmittance values lower than 45% are available that are energy efficient, pleasing and easily seen through. The best option for minimizing interior lighting impacts to sea turtles is to use the darkest tint available. Tints with 25 to 30% transmittance are among the most popular and tints as low as 15% have been used successfully. Many local lighting ordinances require that interior lights cannot be visible from the beach; therefore, the use of higher transmittance tints (such as 45%) often requires installation of additional window treatments to achieve compliance with the ordinance.

If the information above is followed, your home or building is not expected to adversely impact nesting sea turtles, their hatchlings or their habitat. Thank you for doing your part to protect Florida's sea turtles!

*Please email Wildlifelighting@MyFWC.com if you need additional information or help.

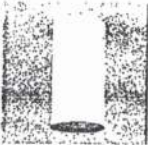
EXAMPLES OF TURTLE FRIENDLY FIXTURES

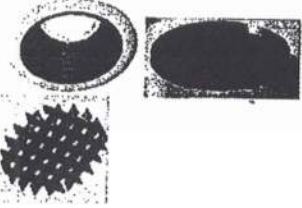
FIXTURE	LAMP & WATTAGE	MOUNTING TYPE & HEIGHT	LOCATION	COMMENTS and/or ADDITIONAL REQUIREMENT
<p>Ceiling Mount Cylinder (with interior black baffles)</p> 	<p>Red/orange/amber LED</p>	<p>Ceiling Surface</p>	<p>If located on shore perpendicular or beach side of structure allow on <u>ground floor</u> only</p>	<p>Interior Black Baffles</p>
<p>Wall Mount Cylinder Down Light (with interior black baffles)</p> 	<p>Red/orange/amber LED</p>	<p>Wall Mount Downward Directed 8 ft from floor</p>	<p>If located on shore perpendicular or beach side of structure allow on <u>first habitable floor</u> only</p>	<p>Interior Black Baffles Hex cell louvers may be required to decrease wall wash</p>
<p>Recessed Ceiling Canister</p> 	<p>Red/orange/amber LED</p> <p><u>The following short wavelength lamps may only be used for covered driveway entry on landward side of structures</u></p> <ul style="list-style-type: none"> • Halogen lamp • PAR spot lamps • LED lamps • HPS lamps • Compact Fluorescent 	<p>Recessed Ceiling</p>	<p>If located on shore perpendicular or beach side of structure allow on <u>ground floor</u> only</p>	<p>Interior black baffles Hex cell (honeycomb) louver</p>

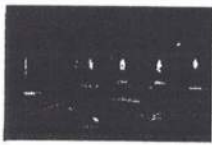
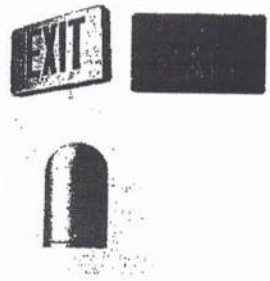
<p>Water Feature Lighting</p> 	<p>Red/orange/amber LED</p>	<p>Light must be downward or horizontally directed</p> <p><u>DO NOT direct light up</u></p>	<p>Submerged lights are only allowed on landward side of structure and only if fully shielded from beach by structure</p>	
<p>Underwater Swimming Pool Lighting</p> 	<p>Red/orange/amber LED</p>			
<p>Emergency Egress Lighting</p> 	<p>Red LED Exit signs</p> <p>Full cut off downward directed Emergency egress fixtures may use short wavelength lamps</p>			<p>Short wavelength lamped emergency egress fixtures must be specified on fixture schedule and plans to be on separate circuit that will only illuminate fixtures during power outage</p>

Project Name:

Part Number:

Type:

AMBER FULL CUTOFF WALL PACK - 50W**OUTDOOR**407-478-3759
www.ilp-inc.com**FEATURES**

- Die-cast aluminum housing
- Type II, III, and IV optics available
- Hinged full cutoff front frame
- 1/2" Coin plugs with o-rings for conduit or optional photocell
- Textured architectural bronze powdercoat finish over a chromate conversion coating
- Cast-in template for mounting directly over a 4" recessed outlet box
- Amber LEDs 585-595 nm Dominant Wave Length
- ETL Listed for wet locations
- Dark Sky Compliant
- Custom colors available upon request
- 5 Year warranty

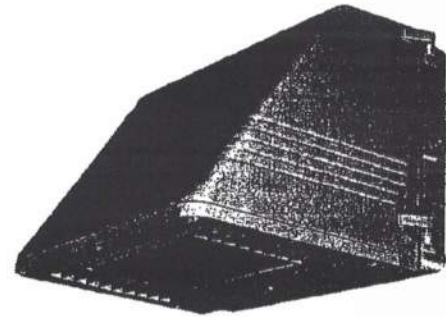
**SUITABLE APPLICATIONS**

- Parking Lots
- Beachfront Buildings
- Pathways
- Pool Decks
- Hotels
- Retail
- Shopping Centers
- Condominium

LED SYSTEMS INFO

	AMBER	T4	FWC
Calculated L70		>33.3K	>33.3K
Delivered Lumens		1,756 lm	818 lm
Total Input Watts		50 W	50 W
Maximum Ambient Temperature		120°F	120°F
Universal Driver		120-277 V	120-277 V

LED system data above is based and scaled Goniphotometer results.
Note: E5 file available for T4 and FWC configuration.
Note: FWC system data is based on T4 and FGS options installed.
Note: FWC has T4 optics and FGS as standard options.



FGS option available:



Wildlife Lighting Certification Number: 001846

ORDERING GUIDE:

Series	Watts	Driver	Color	Optics	Options
<input type="checkbox"/> WPCS Full Cutoff Wall Pack	<input type="checkbox"/> 50WLED	<input type="checkbox"/> UNIV 120-277V	<input type="checkbox"/> AMBER	<input type="checkbox"/> T2 <input type="checkbox"/> T3 <input type="checkbox"/> T4	<input type="checkbox"/> FGS Front Side Glare Shield <input type="checkbox"/> PCU Electronic UNIV Photocell (120-277V) <input type="checkbox"/> F/WLBCP05 5W LED Factory Installed Battery Backup <input type="checkbox"/> SP1 10KA Univolt Surge Protection <input type="checkbox"/> SP2 22KA Univolt Surge Protection

AMBER FULL CUTOFF WALL PACK - 50W

OUTDOOR

LINE DRAWING

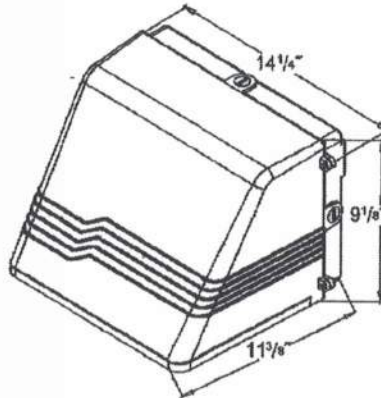

WPCS-50WLED-UNIV-AMBER-T4

SUMMARY DATA

HEMISPHERES TESTED:	BOTH
EFFICIENCY (Downlight/Uplight):	101.5 % / 0.0 %
EFFICIENCY (Street/House):	50.4 % / 50.9 %
ROADWAY CLASSIFICATION:	TYPE IV, SHORT
CUTOFF CLASSIFICATION:	NONCUTOFF
LUMENS:	1,758.29
INPUT WATTS:	0

CANDELA PLOT

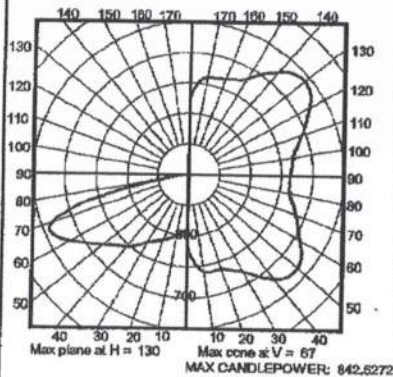

Photometric values based upon tests performed in compliance w/ LM-79. Download IES files at www.lp-inc.com

WPCS-50WLED-UNIV-AMBER-T4-FGS

SUMMARY DATA

HEMISPHERES TESTED:	BOTH
EFFICIENCY (Downlight/Uplight):	101.1 % / 0.1 %
EFFICIENCY (Street/House):	50.8 % / 50.6 %
ROADWAY CLASSIFICATION:	TYPE II, SHORT
CUTOFF CLASSIFICATION:	SEMICUTOFF
LUMENS:	817.69
INPUT WATTS:	0

CANDELA PLOT

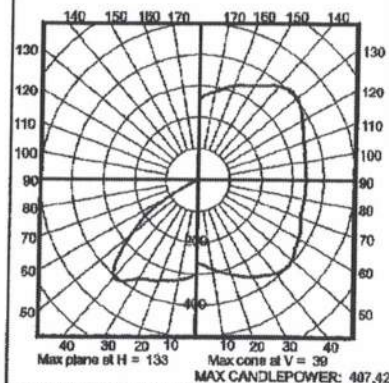

Photometric values based upon tests performed in compliance w/ LM-79. Download IES files at www.lp-inc.com



CERTIFICATE OF LIABILITY INSURANCE

DATE (MM/DD/YYYY)

09/13/2024

THIS CERTIFICATE IS ISSUED AS A MATTER OF INFORMATION ONLY AND CONFERS NO RIGHTS UPON THE CERTIFICATE HOLDER. THIS CERTIFICATE DOES NOT AFFIRMATIVELY OR NEGATIVELY AMEND, EXTEND OR ALTER THE COVERAGE AFFORDED BY THE POLICIES BELOW. THIS CERTIFICATE OF INSURANCE DOES NOT CONSTITUTE A CONTRACT BETWEEN THE ISSUING INSURER(S), AUTHORIZED REPRESENTATIVE OR PRODUCER, AND THE CERTIFICATE HOLDER.

IMPORTANT: If the certificate holder is an ADDITIONAL INSURED, the policy(ies) must have ADDITIONAL INSURED provisions or be endorsed. If SUBROGATION IS WAIVED, subject to the terms and conditions of the policy, certain policies may require an endorsement. A statement on this certificate does not confer rights to the certificate holder in lieu of such endorsement(s).

PRODUCER The Risk Management Group, Inc 7300 N Kendall Dr #202 Miami FL 33156	CONTACT NAME: Francesca Signori PHONE (A/C, No, Ext): (786) 581-5550 FAX (A/C, No): (786) 551-0156 E-MAIL ADDRESS: francesca@trmg.net <table border="1" style="width:100%; border-collapse: collapse;"> <tr> <th style="text-align: left;">INSURER(S) AFFORDING COVERAGE</th> <th style="text-align: left;">NAIC #</th> </tr> <tr> <td>INSURER A: Nationwide General Insurance Co</td> <td>002356</td> </tr> <tr> <td>INSURER B: Technology Insurance Company, Inc</td> <td>42378</td> </tr> <tr> <td>INSURER C:</td> <td></td> </tr> <tr> <td>INSURER D:</td> <td></td> </tr> <tr> <td>INSURER E:</td> <td></td> </tr> <tr> <td>INSURER F:</td> <td></td> </tr> </table>	INSURER(S) AFFORDING COVERAGE	NAIC #	INSURER A: Nationwide General Insurance Co	002356	INSURER B: Technology Insurance Company, Inc	42378	INSURER C:		INSURER D:		INSURER E:		INSURER F:	
INSURER(S) AFFORDING COVERAGE	NAIC #														
INSURER A: Nationwide General Insurance Co	002356														
INSURER B: Technology Insurance Company, Inc	42378														
INSURER C:															
INSURER D:															
INSURER E:															
INSURER F:															
INSURED K & I Electric Inc 3815 NW 125 St Opa-locka FL 33054															

COVERAGES **CERTIFICATE NUMBER:** CL249336660 **REVISION NUMBER:**

THIS IS TO CERTIFY THAT THE POLICIES OF INSURANCE LISTED BELOW HAVE BEEN ISSUED TO THE INSURED NAMED ABOVE FOR THE POLICY PERIOD INDICATED. NOTWITHSTANDING ANY REQUIREMENT, TERM OR CONDITION OF ANY CONTRACT OR OTHER DOCUMENT WITH RESPECT TO WHICH THIS CERTIFICATE MAY BE ISSUED OR MAY PERTAIN, THE INSURANCE AFFORDED BY THE POLICIES DESCRIBED HEREIN IS SUBJECT TO ALL THE TERMS, EXCLUSIONS AND CONDITIONS OF SUCH POLICIES. LIMITS SHOWN MAY HAVE BEEN REDUCED BY PAID CLAIMS.

INSR LTR	TYPE OF INSURANCE	ADDL INSD	SUBR WVD	POLICY NUMBER	POLICY EFF (MM/DD/YYYY)	POLICY EXP (MM/DD/YYYY)	LIMITS
A	<input checked="" type="checkbox"/> COMMERCIAL GENERAL LIABILITY <input type="checkbox"/> CLAIMS-MADE <input checked="" type="checkbox"/> OCCUR GEN'L AGGREGATE LIMIT APPLIES PER: <input checked="" type="checkbox"/> POLICY <input type="checkbox"/> PRO-JECT <input type="checkbox"/> LOC OTHER:	Y		ACP CG023200495039	08/31/2024	08/31/2025	EACH OCCURRENCE \$ 1,000,000
	DAMAGE TO RENTED PREMISES (Ea occurrence) \$ 50,000						
							MED EXP (Any one person) \$ 5,000
							PERSONAL & ADV INJURY \$ 1,000,000
							GENERAL AGGREGATE \$ 2,000,000
							PRODUCTS - COMP/OP AGG \$ 2,000,000
							\$
	AUTOMOBILE LIABILITY						COMBINED SINGLE LIMIT (Ea accident) \$
	<input type="checkbox"/> ANY AUTO <input type="checkbox"/> OWNED AUTOS ONLY <input type="checkbox"/> SCHEDULED AUTOS <input type="checkbox"/> HIRED AUTOS ONLY <input type="checkbox"/> NON-OWNED AUTOS ONLY						BODILY INJURY (Per person) \$
							BODILY INJURY (Per accident) \$
							PROPERTY DAMAGE (Per accident) \$
							\$
	UMBRELLA LIAB						EACH OCCURRENCE \$
	EXCESS LIAB						AGGREGATE \$
	DED RETENTION \$						\$
B	WORKERS COMPENSATION AND EMPLOYERS' LIABILITY ANY PROPRIETOR/PARTNER/EXECUTIVE OFFICER/MEMBER EXCLUDED? (Mandatory in NH) <input type="checkbox"/> Y / N If yes, describe under DESCRIPTION OF OPERATIONS below	N/A		TWC4480871	09/01/2024	09/01/2025	<input checked="" type="checkbox"/> PER STATUTE <input type="checkbox"/> OTHER
	E.L. EACH ACCIDENT \$ 1,000,000						
	E.L. DISEASE - EA EMPLOYEE \$ 1,000,000						
	E.L. DISEASE - POLICY LIMIT \$ 1,000,000						

DESCRIPTION OF OPERATIONS / LOCATIONS / VEHICLES (ACORD 101, Additional Remarks Schedule, may be attached if more space is required)

License # EC13005295

Hollywood CRA is an additional insured under General Liability if required by written contract per Blanket endorsement number NCG 72 46 01 20 copy attached.

CERTIFICATE HOLDER

Hollywood CRA 1948 Harrison Street Hollywood FL 33020	
---	--

CANCELLATION

SHOULD ANY OF THE ABOVE DESCRIBED POLICIES BE CANCELLED BEFORE THE EXPIRATION DATE THEREOF, NOTICE WILL BE DELIVERED IN ACCORDANCE WITH THE POLICY PROVISIONS. AUTHORIZED REPRESENTATIVE <i>Frank Acosta</i>	
--	--

© 1988-2015 ACORD CORPORATION. All rights reserved.

THIS ENDORSEMENT CHANGES THE POLICY. PLEASE READ IT CAREFULLY.

ADDITIONAL INSURED – AUTOMATIC STATUS FOR OTHER PARTIES WHEN REQUIRED IN WRITTEN CONSTRUCTION AGREEMENT - INCLUDING ONGOING OPERATIONS

This endorsement modifies insurance provided under the following:

COMMERCIAL GENERAL LIABILITY COVERAGE PART

A. Section II – Who Is An Insured is amended to include as an additional insured:

Ongoing Operations

1. Any person or organization for whom you are performing operations when you and such person or organization have agreed in writing in a contract or agreement that such person or organization be added as an additional insured on your policy; and
2. Any other person or organization you are required to add as an additional insured under the contract or agreement described in Paragraph 1. above.

Such person(s) or organization(s) is an additional insured only with respect to liability for "bodily injury", "property damage" or "personal and advertising injury" caused, in whole or in part, by:

- a. Your acts or omissions; or
- b. The acts or omissions of those acting on your behalf;

in the performance of your ongoing operations for the additional insured.

However, the insurance afforded to such additional insured described above:

- a. Only applies to the extent permitted by law; and
- b. Will not be broader than that which you are required by the contract or agreement to provide for such additional insured.

A person's or organization's status as an additional insured for ongoing operations ends when your operations for the person or organization described in Paragraph 1. above are completed.

With respect to insurance afforded to these additional insureds for ongoing operations, this insurance does not apply to "bodily injury" or "property damage" occurring after:

- a. All work, including material, parts or equipment furnished in connection with such work, on the project (other than

service, maintenance or repairs) to be performed by or on behalf of the additional insured(s) at the location of the covered operations has been completed: or

- b. that operation of "your work" out of which the injury or damage arises has been put to its intended use by any person or organization other than another contractor or subcontractor engaged in performing operations for a principal as a part of the same project.

B. Section II – Who Is An Insured is amended to include as an additional insured:

Products–Completed Operations

Any person or organization with whom you have agreed in writing in a contract or agreement that such person or organization be added as an additional insured on your policy with respect to liability for "bodily injury" or "property damage" caused, in whole or in part, by "your work" performed for such person or organization and included in the "products-completed operations hazard".

However, the insurance afforded to such additional insured described above:

- a. Only applies to the extent permitted by law; and
- b. Will not be broader than that which you are required by the contract or agreement to provide for such additional insured.

C. With respect to the insurance afforded to these additional insureds, this insurance does not apply to "bodily injury", "property damage" or "personal and advertising injury" arising out of the rendering

of, or the failure to render, any professional architectural, engineering or surveying services, including:

1. The preparing, approving, or failing to prepare or approve, maps, shop drawings, opinions, reports, surveys, field orders, change orders or drawings and specifications; or
2. Supervisory, inspection, architectural or engineering activities.

This exclusion applies even if the claims against any insured allege negligence or other wrongdoing in the supervision, hiring, employment, training or monitoring of others by that insured, if the "occurrence" which caused the "bodily injury" or "property damage", or the offense which caused the "personal and advertising injury", involved the rendering of, or the failure to render, any professional architectural, engineering or surveying services.

- D. With respect to the insurance afforded to these additional insureds, the following is added to **Section III – Limits Of Insurance:**

The most we will pay on behalf of the additional insured is the amount of insurance:

1. Required by the contract or agreement described in Paragraph **A.1.** or Paragraph **B.;** or
2. Available under the applicable Limits of Insurance shown in the Declarations;
whichever is less.

This endorsement shall not increase the applicable Limits of Insurance shown in the Declarations.

- E. With respect to the insurance afforded to these additional insureds, the following is added to **Section IV – Commercial General Liability Conditions, Condition 4. Other Insurance** and supersedes any provision to the contrary:

Primary And Noncontributory Insurance

This insurance is primary to and will not seek contribution from any other insurance available to an additional insured under your policy provided that:

- (1) The additional insured is a Named Insured under such other insurance; and
- (2) You have agreed in writing in a contract or agreement that this insurance would be primary and would not seek contribution from any other insurance available to the additional insured.

All terms and conditions of this policy apply unless modified by this endorsement.



CERTIFICATE OF LIABILITY INSURANCE

DATE (MM/DD/YYYY)
09/13/2024

THIS CERTIFICATE IS ISSUED AS A MATTER OF INFORMATION ONLY AND CONFERS NO RIGHTS UPON THE CERTIFICATE HOLDER. THIS CERTIFICATE DOES NOT AFFIRMATIVELY OR NEGATIVELY AMEND, EXTEND OR ALTER THE COVERAGE AFFORDED BY THE POLICIES BELOW. THIS CERTIFICATE OF INSURANCE DOES NOT CONSTITUTE A CONTRACT BETWEEN THE ISSUING INSURER(S), AUTHORIZED REPRESENTATIVE OR PRODUCER, AND THE CERTIFICATE HOLDER.

IMPORTANT: If the certificate holder is an ADDITIONAL INSURED, the policy(ies) must have ADDITIONAL INSURED provisions or be endorsed. If SUBROGATION IS WAIVED, subject to the terms and conditions of the policy, certain policies may require an endorsement. A statement on this certificate does not confer rights to the certificate holder in lieu of such endorsement(s).

PRODUCER The Risk Management Group, Inc 7300 N Kendall Dr #202 Miami FL 33156	CONTACT NAME: Francesca Signori PHONE (A/C, No, Ext): (786) 581-5550 FAX (A/C, No): (786) 551-0156 E-MAIL ADDRESS: francesca@trmg.net												
INSURER(S) AFFORDING COVERAGE													
INSURED K & I Electric Inc 3815 NW 125 St Opa-locka FL 33054	<table border="1" style="width: 100%; border-collapse: collapse;"> <tr> <td style="width: 80%;">INSURER A: Nationwide General Insurance Co</td> <td style="width: 20%;">NAIC # 002356</td> </tr> <tr> <td>INSURER B: Technology Insurance Company, Inc</td> <td>42378</td> </tr> <tr> <td>INSURER C:</td> <td></td> </tr> <tr> <td>INSURER D:</td> <td></td> </tr> <tr> <td>INSURER E:</td> <td></td> </tr> <tr> <td>INSURER F:</td> <td></td> </tr> </table>	INSURER A: Nationwide General Insurance Co	NAIC # 002356	INSURER B: Technology Insurance Company, Inc	42378	INSURER C:		INSURER D:		INSURER E:		INSURER F:	
INSURER A: Nationwide General Insurance Co	NAIC # 002356												
INSURER B: Technology Insurance Company, Inc	42378												
INSURER C:													
INSURER D:													
INSURER E:													
INSURER F:													

COVERAGES **CERTIFICATE NUMBER:** CL249336660 **REVISION NUMBER:**

THIS IS TO CERTIFY THAT THE POLICIES OF INSURANCE LISTED BELOW HAVE BEEN ISSUED TO THE INSURED NAMED ABOVE FOR THE POLICY PERIOD INDICATED. NOTWITHSTANDING ANY REQUIREMENT, TERM OR CONDITION OF ANY CONTRACT OR OTHER DOCUMENT WITH RESPECT TO WHICH THIS CERTIFICATE MAY BE ISSUED OR MAY PERTAIN, THE INSURANCE AFFORDED BY THE POLICIES DESCRIBED HEREIN IS SUBJECT TO ALL THE TERMS, EXCLUSIONS AND CONDITIONS OF SUCH POLICIES. LIMITS SHOWN MAY HAVE BEEN REDUCED BY PAID CLAIMS.

INSR LTR	TYPE OF INSURANCE	ADDL INSD	SUBR WVD	POLICY NUMBER	POLICY EFF (MM/DD/YYYY)	POLICY EXP (MM/DD/YYYY)	LIMITS
A	<input checked="" type="checkbox"/> COMMERCIAL GENERAL LIABILITY <input type="checkbox"/> CLAIMS-MADE <input checked="" type="checkbox"/> OCCUR GEN'L AGGREGATE LIMIT APPLIES PER: <input checked="" type="checkbox"/> POLICY <input type="checkbox"/> PRO-JECT <input type="checkbox"/> LOC OTHER:	Y		ACP CG023200495039	08/31/2024	08/31/2025	EACH OCCURRENCE \$ 1,000,000
	DAMAGE TO RENTED PREMISES (Ea occurrence) \$ 50,000						
	MED EXP (Any one person) \$ 5,000						
	<input type="checkbox"/> AUTOMOBILE LIABILITY <input type="checkbox"/> ANY AUTO <input type="checkbox"/> OWNED AUTOS ONLY <input type="checkbox"/> SCHEDULED AUTOS <input type="checkbox"/> HIRED AUTOS ONLY <input type="checkbox"/> NON-OWNED AUTOS ONLY						COMBINED SINGLE LIMIT (Ea accident) \$
	<input type="checkbox"/> UMBRELLA LIAB <input type="checkbox"/> OCCUR <input type="checkbox"/> EXCESS LIAB <input type="checkbox"/> CLAIMS-MADE DED RETENTION \$						EACH OCCURRENCE \$
B	<input type="checkbox"/> WORKERS COMPENSATION AND EMPLOYERS' LIABILITY ANY PROPRIETOR/PARTNER/EXECUTIVE OFFICER/MEMBER EXCLUDED? (Mandatory in NH) <input type="checkbox"/> If yes, describe under DESCRIPTION OF OPERATIONS below		N/A	TWC4480871	09/01/2024	09/01/2025	<input checked="" type="checkbox"/> PER STATUTE <input type="checkbox"/> OTHER E.L. EACH ACCIDENT \$ 1,000,000 E.L. DISEASE - EA EMPLOYEE \$ 1,000,000 E.L. DISEASE - POLICY LIMIT \$ 1,000,000

DESCRIPTION OF OPERATIONS / LOCATIONS / VEHICLES (ACORD 101, Additional Remarks Schedule, may be attached if more space is required)

License # EC13005295

 Oxford Towers is an additional insured under General Liability if required by written contract per Blanket endorsement number NCG 72 46 01 20 copy attached.

CERTIFICATE HOLDER Oxford Towers 1948 Harrison Street Hollywood FL 33020	CANCELLATION SHOULD ANY OF THE ABOVE DESCRIBED POLICIES BE CANCELLED BEFORE THE EXPIRATION DATE THEREOF, NOTICE WILL BE DELIVERED IN ACCORDANCE WITH THE POLICY PROVISIONS. AUTHORIZED REPRESENTATIVE <p style="text-align: center; font-family: cursive;">Frank Acosta</p>
--	---

THIS ENDORSEMENT CHANGES THE POLICY. PLEASE READ IT CAREFULLY.

ADDITIONAL INSURED – AUTOMATIC STATUS FOR OTHER PARTIES WHEN REQUIRED IN WRITTEN CONSTRUCTION AGREEMENT - INCLUDING ONGOING OPERATIONS

This endorsement modifies insurance provided under the following:

COMMERCIAL GENERAL LIABILITY COVERAGE PART

A. Section II – Who Is An Insured is amended to include as an additional insured:

Ongoing Operations

1. Any person or organization for whom you are performing operations when you and such person or organization have agreed in writing in a contract or agreement that such person or organization be added as an additional insured on your policy; and
2. Any other person or organization you are required to add as an additional insured under the contract or agreement described in Paragraph 1. above.

Such person(s) or organization(s) is an additional insured only with respect to liability for "bodily injury", "property damage" or "personal and advertising injury" caused, in whole or in part, by:

- a. Your acts or omissions; or
- b. The acts or omissions of those acting on your behalf;

in the performance of your ongoing operations for the additional insured.

However, the insurance afforded to such additional insured described above:

- a. Only applies to the extent permitted by law; and
- b. Will not be broader than that which you are required by the contract or agreement to provide for such additional insured.

A person's or organization's status as an additional insured for ongoing operations ends when your operations for the person or organization described in Paragraph 1. above are completed.

With respect to insurance afforded to these additional insureds for ongoing operations, this insurance does not apply to "bodily injury" or "property damage" occurring after:

- a. All work, including material, parts or equipment furnished in connection with such work, on the project (other than

service, maintenance or repairs) to be performed by or on behalf of the additional insured(s) at the location of the covered operations has been completed: or

- b. that operation of "your work" out of which the injury or damage arises has been put to its intended use by any person or organization other than another contractor or subcontractor engaged in performing operations for a principal as a part of the same project.

B. Section II – Who Is An Insured is amended to include as an additional insured:

Products–Completed Operations

Any person or organization with whom you have agreed in writing in a contract or agreement that such person or organization be added as an additional insured on your policy with respect to liability for "bodily injury" or "property damage" caused, in whole or in part, by "your work" performed for such person or organization and included in the "products-completed operations hazard".

However, the insurance afforded to such additional insured described above:

- a. Only applies to the extent permitted by law; and
- b. Will not be broader than that which you are required by the contract or agreement to provide for such additional insured.

C. With respect to the insurance afforded to these additional insureds, this insurance does not apply to "bodily injury", "property damage" or "personal and advertising injury" arising out of the rendering

of, or the failure to render, any professional architectural, engineering or surveying services, including:

1. The preparing, approving, or failing to prepare or approve, maps, shop drawings, opinions, reports, surveys, field orders, change orders or drawings and specifications; or
2. Supervisory, inspection, architectural or engineering activities.

This exclusion applies even if the claims against any insured allege negligence or other wrongdoing in the supervision, hiring, employment, training or monitoring of others by that insured, if the "occurrence" which caused the "bodily injury" or "property damage", or the offense which caused the "personal and advertising injury", involved the rendering of, or the failure to render, any professional architectural, engineering or surveying services.

- D. With respect to the insurance afforded to these additional insureds, the following is added to **Section III – Limits Of Insurance:**

The most we will pay on behalf of the additional insured is the amount of insurance:

1. Required by the contract or agreement described in Paragraph **A.1.** or Paragraph **B.;** or
2. Available under the applicable Limits of Insurance shown in the Declarations;
whichever is less.

This endorsement shall not increase the applicable Limits of Insurance shown in the Declarations.

- E. With respect to the insurance afforded to these additional insureds, the following is added to **Section IV – Commercial General Liability Conditions, Condition 4. Other Insurance** and supersedes any provision to the contrary:

Primary And Noncontributory Insurance

This insurance is primary to and will not seek contribution from any other insurance available to an additional insured under your policy provided that:

- (1) The additional insured is a Named Insured under such other insurance; and
- (2) You have agreed in writing in a contract or agreement that this insurance would be primary and would not seek contribution from any other insurance available to the additional insured.

All terms and conditions of this policy apply unless modified by this endorsement.

Ron DeSantis, Governor



Melanie S. Griffin, Secretary



STATE OF FLORIDA
DEPARTMENT OF BUSINESS AND PROFESSIONAL REGULATION
ELECTRICAL CONTRACTORS' LICENSING BOARD

THE ELECTRICAL CONTRACTOR HEREIN IS CERTIFIED UNDER THE
PROVISIONS OF CHAPTER 489, FLORIDA STATUTES



MELCON, LUIS JOSE

K&I ELECTRIC INC.
3815 NW 125TH STREET
OPA-LOCKA FL 33054

LICENSE NUMBER: EC13005295

EXPIRATION DATE: AUGUST 31, 2024

Always verify licenses online at MyFloridaLicense.com



Do not alter this document in any form.

This is your license. It is unlawful for anyone other than the licensee to use this document.

Date of this notice: 07-21-2021

Employer Identification Number:
87-1781371

Form: SS-4

Number of this notice: CP 575 A

For assistance you may call us at:
1-800-829-4933

K&I ELECTRIC INC
% KAREL REYES
3815 NW 125 STREET
OPA LOCKA, FL 33054

IF YOU WRITE, ATTACH THE
STUB AT THE END OF THIS NOTICE.

WE ASSIGNED YOU AN EMPLOYER IDENTIFICATION NUMBER

Thank you for applying for an Employer Identification Number (EIN). We assigned you EIN 87-1781371. This EIN will identify you, your business accounts, tax returns, and documents, even if you have no employees. Please keep this notice in your permanent records.

When filing tax documents, payments, and related correspondence, it is very important that you use your EIN and complete name and address exactly as shown above. Any variation may cause a delay in processing, result in incorrect information in your account, or even cause you to be assigned more than one EIN. If the information is not correct as shown above, please make the correction using the attached tear off stub and return it to us.

Based on the information received from you or your representative, you must file the following form(s) by the date(s) shown.

Form 1120

04/15/2022

If you have questions about the form(s) or the due date(s) shown, you can call us at the phone number or write to us at the address shown at the top of this notice. If you need help in determining your annual accounting period (tax year), see Publication 538, *Accounting Periods and Methods*.

We assigned you a tax classification based on information obtained from you or your representative. It is not a legal determination of your tax classification, and is not binding on the IRS. If you want a legal determination of your tax classification, you may request a private letter ruling from the IRS under the guidelines in Revenue Procedure 2004-1, 2004-1 I.R.B. 1 (or superseding Revenue Procedure for the year at issue). Note: Certain tax classification elections can be requested by filing Form 8832, *Entity Classification Election*. See Form 8832 and its instructions for additional information.

IMPORTANT INFORMATION FOR S CORPORATION ELECTION:

If you intend to elect to file your return as a small business corporation, an election to file a Form 1120-S must be made within certain timeframes and the corporation must meet certain tests. All of this information is included in the instructions for Form 2553, *Election by a Small Business Corporation*.



www.allamericanasphaltpaving.com

Proposal

FROM: **All American Asphalt LLC.**

Page. No. 1

1645 Palm Beach Lakes Blvd. Ste. #1200

West Palm Beach, FL. 33401

(561) 684-9183

PROPOSAL SUBMITTED TO:

Name: Oxford Towers

RE: Parking improvements

Phone: (786) 410- 6727

Date: 6/25/24

Street: 211 Ocean Dr.

City & State: Hollywood, FL 33019

Surface Preparation:

Approx. 26,000 Sq. Ft.

- Clean and prep. Area by machine and manual methods.
- Pre-treat oil spots prior to coating.

Asphalt repair:

- Saw-cut square holes for proper appearance.
- Remove failed asphalt and/or tree roots as necessary.
- Patch full-depth with S-III hot-mix asphalt.

Seal-coating:

- Apply two coats of cold tar sealer meeting or exceeding federal specification RP-255-E. Both coats will contain "Star Sealer," four lbs. of silica sand per gallon, and latex modifier.

Striping:

- Install all parking lines and markings with D.O.T. approved paint.
- Paint all car-stops.

Broken car-stops can be replaced for \$100 per stop

All the work is to be completed in a substantial and workmanlike manner for the sum of **Six Thousand Five Hundred Dollars (\$6500.00)**. Payment to be made: Fifty percent down, the entire amount of the contract is to be after completion.

All work and labor warranted for one year.

Any alterations or deviation from the above specifications involving extra cost of material or labor will be executed upon written order for same and will become an extra charge over the sum mentioned in this contract. All agreements must be made in writing.

[* Note: Processing fees, Permit fees, or testing fees not included in this price]

Authorized Signature _____

Date: _____

RnR sealcoating estimate

Rick Stevens

2101 n 56 terrace Hollywood fl 33021

Oxford Towers

1501 S. Ocean Drive

Hollywood. FL 33019

Project overview: patch all holes, Seal Coat entire driveway/parking lot, and re-stripe.

Seal coating and stripping will be done in sections to have some parking available. It would be spilt up in 3 separate sections. And would take 4- 5 days to complete entire parking lot. Please have tenants or customers park at recommended parking area of your choice.

Hot asphalt patch: \$1,200.00

Sealcoating: \$3,800.00

Stripping: \$1,500.00

Total Price: \$ 7,500.00

3 year warranty with all asphalt put down.

1 year and 6 month warranty with sealcoating material call trident

3 year warranty on all stripes

All materials used is from star seal of Florida.



THE LINDMAN DIFFERENCE

C.A.
LINDMAN
COMPANIES

www.calindman.com

EXPERIENCE • VALUE • SERVICE • SAFETY • PEACE OF MIND



C.A.
LINDMAN
C O M P A N I E S

C.A. LINDMAN, INC.
10401 Guilford Road
Jessup, MD 20794
Voice: (301) 470-4700
Toll Free: (877) 737-8675
Fax: (301) 470-4708

VALENTE-LINDMAN, LLC
4 Cliff Drive
Englewood, NJ 07631
Voice: 201-816-0606
Fax: 201-816-1313

C.A. LINDMAN, INC.
1900 NW 18th Street
Pompano Beach, FL 33069
Voice: 954-971-3220
Fax: 954-971-3221

CAROLINA RESTORATION
AND WATERPROOFING, INC.
P.O. Box 1007
Creedmoor, NC 27522
Voice: 919-528-6400
Fax: 919-528-4170

www.calindman.com



WHAT'S IMPORTANT TO YOU?

As the owner or manager of a commercial, residential, or historic property, what do you look for in your restoration contractor? Probably the same things we look for — experience, value, service, safety, and peace of mind.

Since our start in 1990, C.A. Lindman has become the nation's leader in structural repair and building restoration, not because of luck but because of hard work and an appreciation for what our customers expect in those they hire to repair and restore their concrete and masonry structures.

The Lindman Difference

Over the years we have augmented our service offerings to accommodate our customers' expanding needs. We have stayed current with the latest techniques and technologies. Despite our growth, however, we have remained true to giving our customers the one-on-one service and attention typical of much smaller companies.

With our focus on safety, quality, and good value, C.A. Lindman promises you what few can — big-company capabilities, with a focus on small-company customer care. We call it the Lindman Difference. It's what distinguishes us from the rest.



Services At-A-Glance

C.A. Lindman is proud to offer services in the following areas:

- *Concrete Repair and Restoration* • *Waterproofing*
- *Masonry Repair and Restoration* • *Historic Restoration*

THE
LINDMAN
DIFFERENCE



BUILDING ON DECADES OF EXPERIENCE

The founders of C.A. Lindman began their professional careers in the industry and offer decades of experience in the restoration and repair business. As hands-on owners, they have a vested interest in making sure that jobs run smoothly.

An Investment in Employee Training

Just as important are the skills of the company's field personnel and management staff. C.A. Lindman hires only seasoned professionals who are as committed as the owners to exceeding customers' expectations. Now numbering more than 500 strong, our people undergo extensive training on the latest state-of-the-art materials, techniques, and equipment, and only quality materials are used on our jobs.

Our focus on building and retaining an experienced workforce has paid dividends to our customers. They know they can count on us to get the job right the first time.

Fast Facts About C.A. Lindman

- *We have completed more than 5,000 projects.*
- *More than two-thirds of our supervisors have worked with us for more than five years.*
- *Our 500 employees work from four different locations in New York, Miami, Raleigh, and Washington, D.C., and are capable of staffing any project on the East Coast.*
- *Our warehouse staff maintains more than \$3 million in company-owned equipment and can deliver to any job site within 24 hours.*



THE
LINDMAN
DIFFERENCE

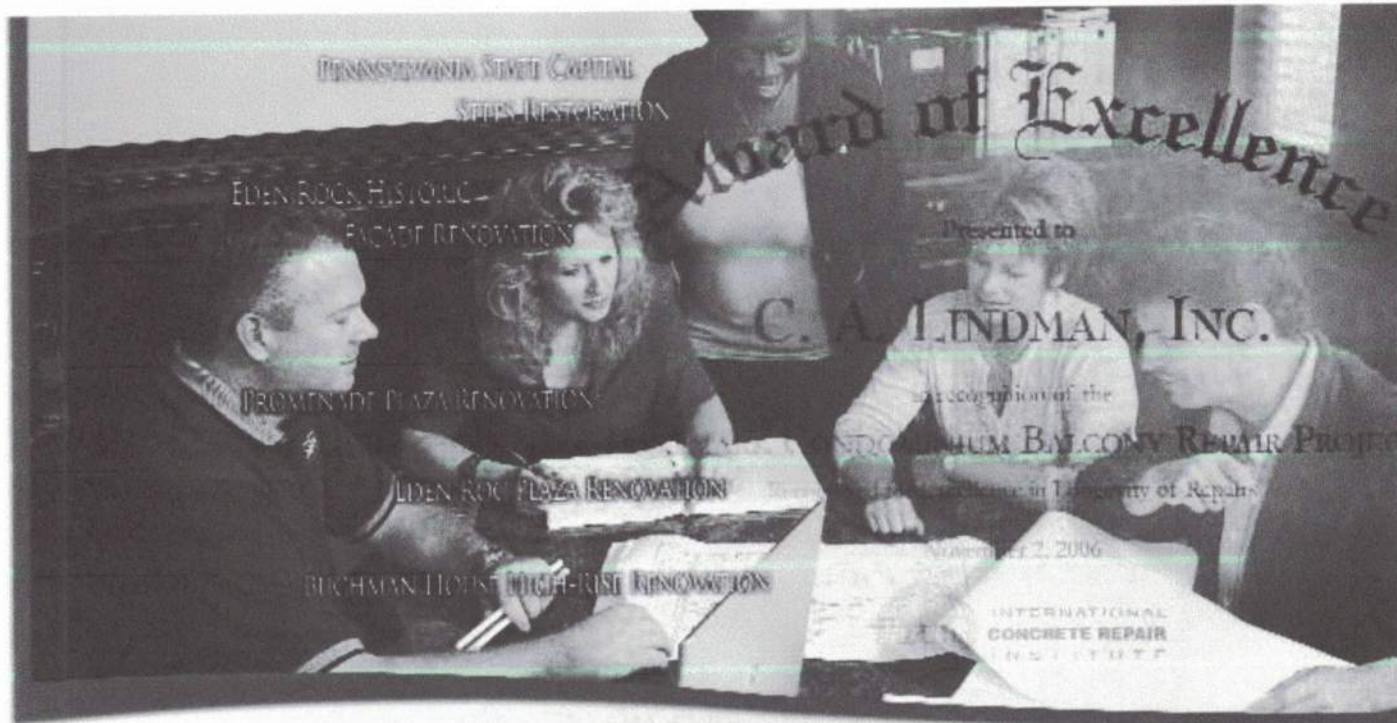

DEFINING VALUE

No one wants to pay high prices. Smart clients want to pay for good value. C.A. Lindman works hard to offer just that — good value. We strive to keep down our prices, without sacrificing service and quality. We do this by:

- *Balancing paying a fair wage against fair pricing*
- *Weighing the investment in new technology against the impact on our prices*
- *Employing extensive in-house management systems that help us keep our prices accurate and fair*
- *Treating our clients with fairness and professionalism during all phases of a job, from bid and execution to final contract adjustments.*

In short, we treat our customers the way we want to be treated. The result? More than 80 percent of our business comes from repeat business and referrals, and our work is acknowledged as being among the best in the nation.



Kudos for a Job Well Done

Others have noticed the value we bring, too. Here are just a few awards that the industry has bestowed on us for a job well done.

International Concrete Repair Institute

Award of Excellence — Marriott Frenchman's Reef Renovation
Award of Excellence — Buchman House High-Rise Renovation
Award of Excellence — Hallmark Condominium Balcony Repair
Award of Excellence — Eden Rock Historic Façade Renovation
Award of Merit — Promenade Plaza Renovation
Award of Merit — Pennsylvania State Capital Steps Restoration
Honorable Mention — Eden Roc Plaza Renovation

Forrester Construction
2002 Subcontractor of the Year

Marriott International
Outstanding Project Certification

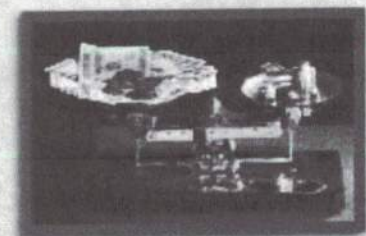

"It's unwise to pay too much...but it's worse to pay too little. When you pay too much, you lose a little money...that is all. When you pay too little, you sometimes lose everything because the thing you bought was incapable of doing the thing it was bought to do. The common law of business balance prohibits paying a little and getting a lot...it can't be done. If you deal with the lowest bidder, it is well to add something for the risk you run. And, if you do that, you will have enough to pay for something better."

— **John Ruskin,**
Art and Social Critic,
1819-1900

THE
LINDMAN
DIFFERENCE

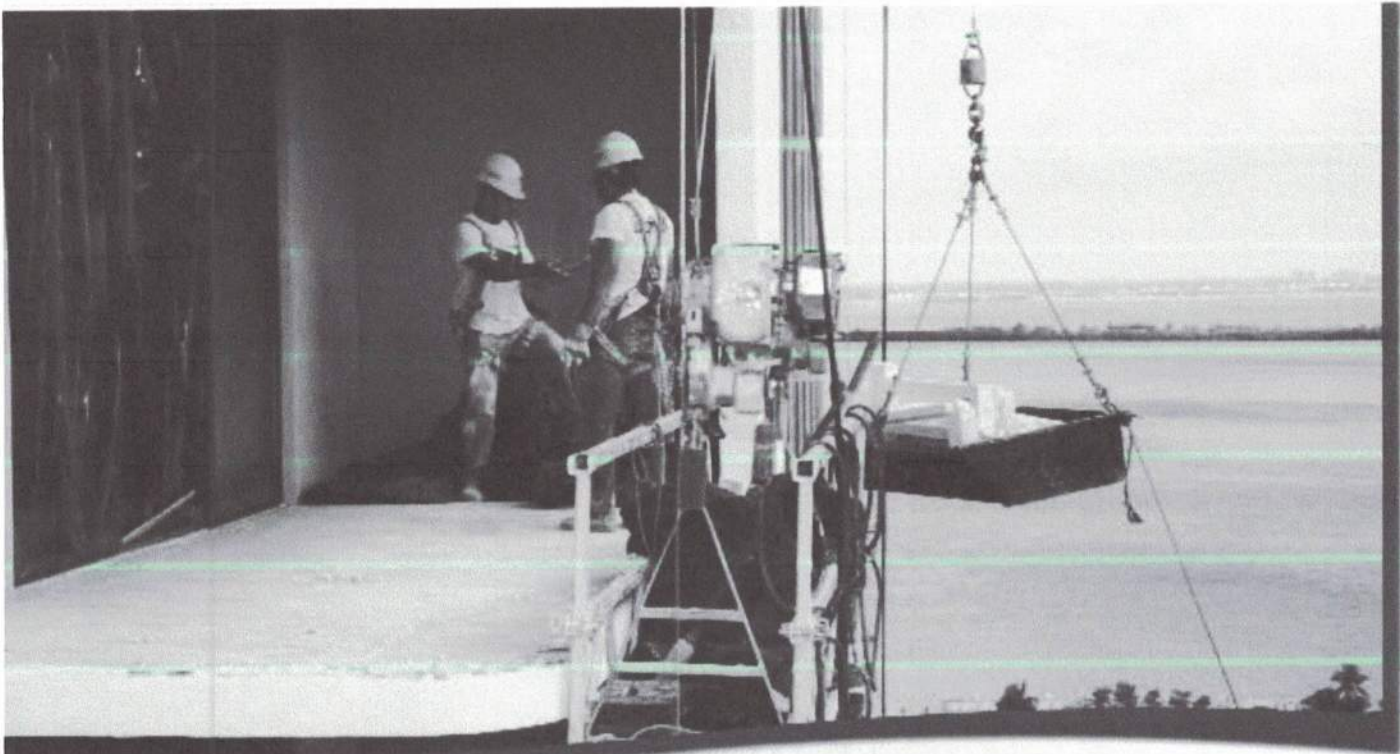

THE SPECTRUM IN REPAIR AND RESTORATION SERVICES

With our diverse knowledge and abilities, C.A. Lindman can meet your needs on the most complex and demanding projects, whether they involve masonry and concrete restoration and waterproofing to historic preservation.

In carrying out our work, we use cutting-edge technology as well as centuries-old techniques to improve, strengthen, waterproof, and renew commercial office buildings, multi-unit apartment complexes, parking garages, historic buildings, monuments, and statuary.

Look to us as your single-source solution for the complete spectrum of repair projects. And remember, too, that no job is too big or too small.

What We Do

- *Architectural Coatings*
- *Balcony Repair*
- *Blastproofing*
- *Carbon Fiber Strengthening*
- *Epoxy/Chemical Injection*
- *Expansion Joint Replacement*
- *Facade Restoration*
- *Garage Repair*
- *Historic Restoration*
- *Hot Rubber Waterproofing*
- *Masonry Restoration*
- *Plaza Restoration*
- *Post-Tension Repair*
- *Structural Concrete Repair*
- *Waterproofing*



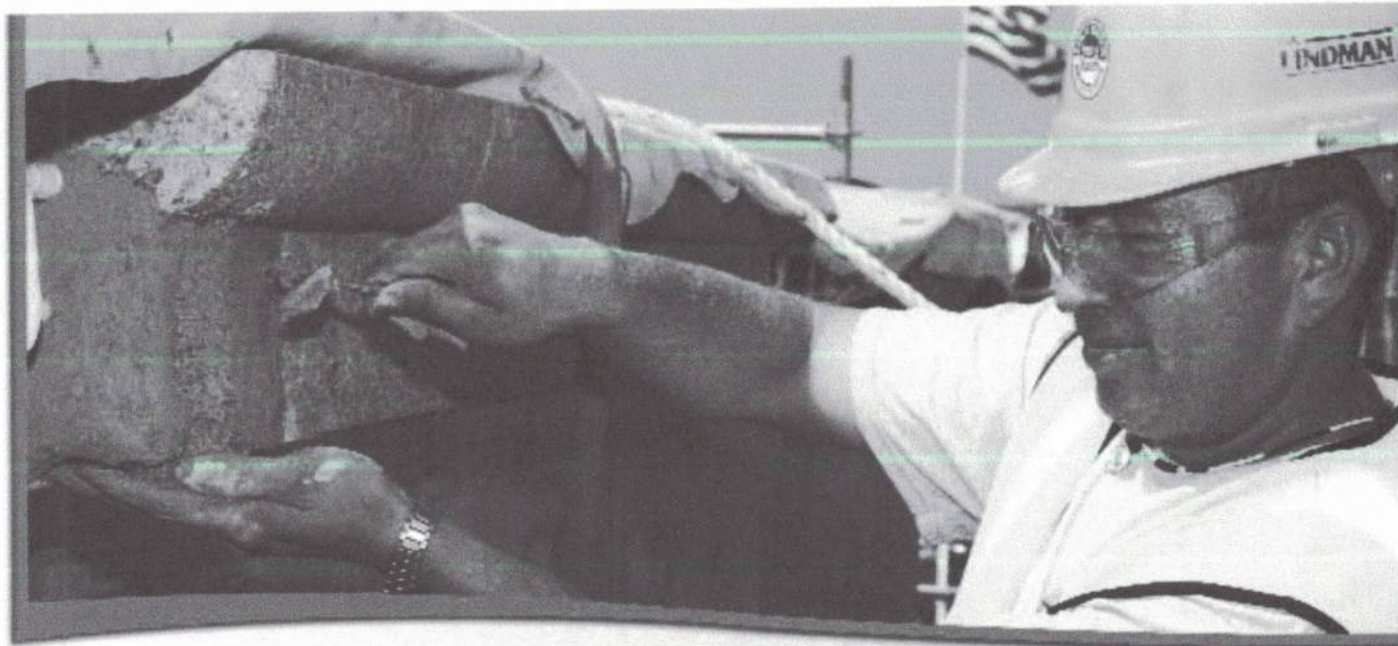

PRESERVING AND PROTECTING MASONRY EXTERIORS

Masonry buildings can appear invincible, but in truth, age, moisture, pollutants, and deferred maintenance all contribute to a slow but steady decline. Left uncorrected, small problems can become big problems in the form of cracks, loose bricks, flaking, and spalling. Not only do they detract from the building's beauty, but eventually lead to structural weakness.

C.A. Lindman incorporates new techniques to supplement well-established repair principles, working in partnership with owners and managers to deliver a long-term, low-cost solution.

Customers from across the country and beyond come to us for:

- *Brick and Stone Repair/Replacement*
- *Repointing*
- *Building Cleaning/Sealer*
- *Expansion Joint Systems Repair*
- *Epoxy Injection*
- *Caulking and Sealants*
- *Exterior Wall Coatings*
- *Thru-Wall Flashing*
- *Jahn Restoration*
- *Historic Restoration*



No Job Too Big or Too Small

Meeting our clients' requirements includes meeting their needs on small jobs, too. We take pride in the hundreds of small jobs we perform each year.

Our willingness to take on all types of projects benefits our customers. They hire only one contractor. This not only assures better coordination and one overall warranty, but saves money as well.

Rest assured that we have the in-house expertise to be your sole source for all types of repairs on all types of structures.



THE
LINDMAN
DIFFERENCE



EXTENDING THE LIFE OF CONCRETE STRUCTURES

Concrete is the material of choice for most commercial properties. Though economical, durable, and readily available, it isn't, however, permanent. Time, water, and weather take their toll on these structures and undermine their strength. Determining the causes of problems and then employing the most effective repair solution are the essence of good building maintenance.

Over the years, we have perfected the technical capabilities needed to repair, strengthen, waterproof, stabilize, and protect all concrete structures, including high-rise office and residential buildings, parking garages, airports, subways, bridges, plaza decks, and industrial plants.

Our commitment to being the best in the industry has earned us recognition as the industry's leading contractor in these services:

- *Expansion Joint Systems*
- *Pedestrian and Vehicular Coating Systems*
- *Parking Deck Restoration*
- *Plaza Deck Restoration*
- *Polyurea Coatings*
- *Chemical Grouts*
- *Exterior Wall Coatings*
- *Above- and Below-Grade Waterproofing*
- *Caulking and Sealants*
- *Epoxy Injection*
- *Building Cleaning/Sealer*
- *Waterproofing Membrane Installation*
- *Paver/Topping Slab Repair/Installation*
- *Concrete Repair/Replacement*
- *Structural Repairs*
- *Interior Waterproofing Systems*
- *Clear Sealer Application*
- *Deck Coating Installation*
- *Blastproofing*

PRESERVING HISTORY

Preserving historic property requires both a special set of technical skills and an appreciation for its importance.

C.A. Lindman offers both. Acting as your contractor, we will work with your architect, engineer, and historic consultant to identify critical needs, develop a cost-effective solution, and coordinate a smooth-running project that assures your property's beauty for posterity.



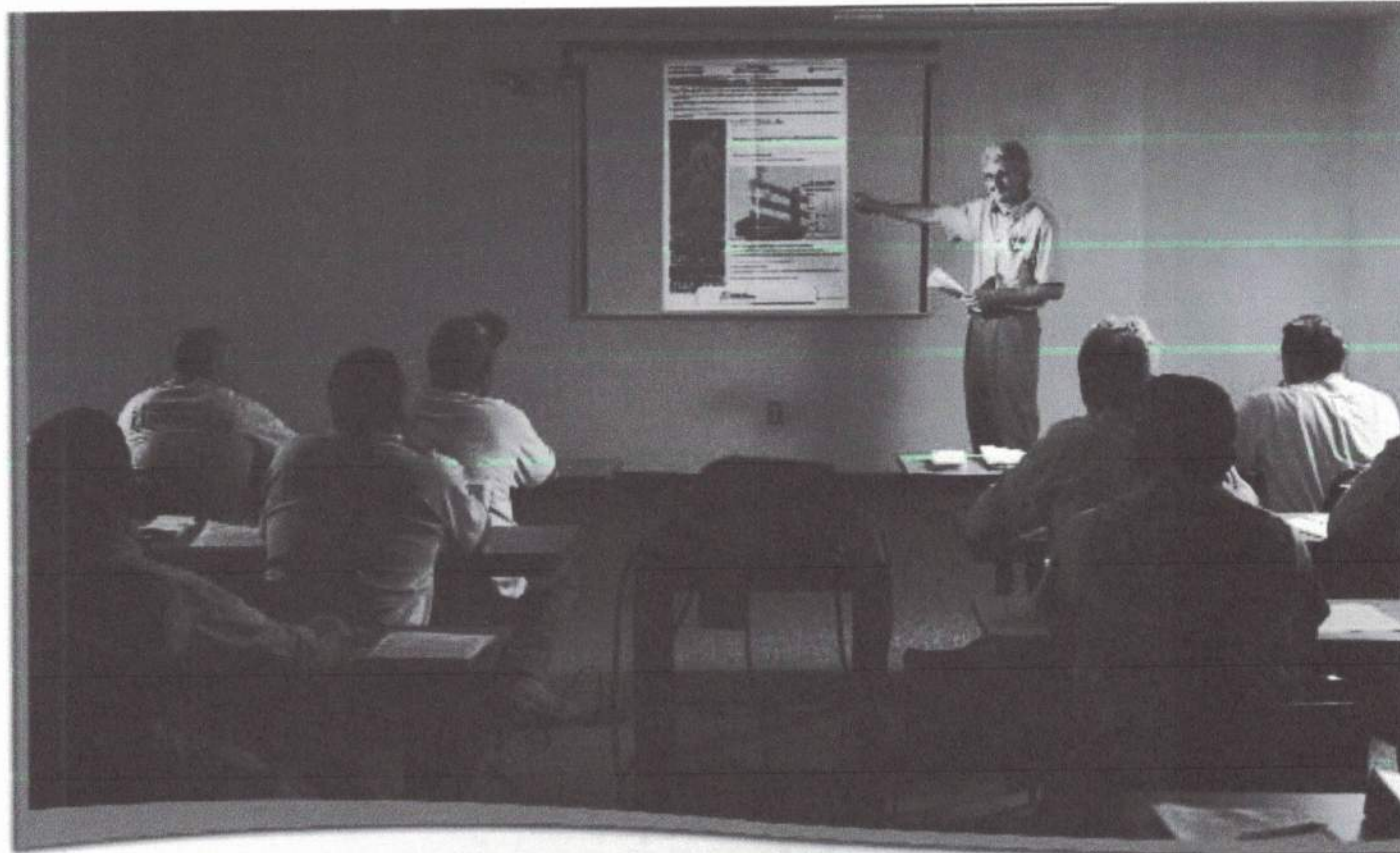

MAINTAINING A STRONG SAFETY CULTURE

Concrete repair and other restorations typically take place on an exposed façade, high above the ground or in occupied buildings. Therefore, it's important that the job be completed quickly, with the least amount of disruption to tenants. Having the right access to equipment, tools, and properly trained technicians becomes paramount — as does strict adherence to safety regulations.

Exceeding OSHA Standards

C.A. Lindman has developed a safety program that exceeds OSHA standards and requirements. In addition to employing a full-time safety officer, who monitors, inspects, and makes sure that our equipment meets specifications, our supervisors are required to:

- *Complete annual training certification, and*
- *Pass an annual test based on our extensive in-house safety manual.*

We also invest in our technicians. Each week, they attend mandatory safety meetings that cover all aspects of job safety. Our employees also undergo First-Aid and CPR training and are well versed on the proper handling all types of equipment and materials.

Safety is important to our customers. It's important to us. And we believe it shows. In 2003 and 2005, the IWIF recognized us with its most prestigious honor — the Contractor's IWIF's Contractor Safety Award.

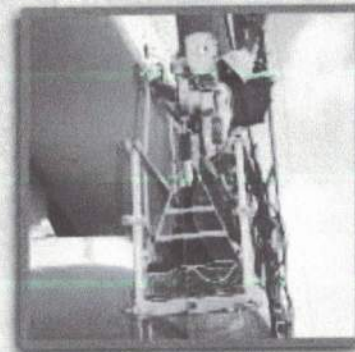

"C.A. Lindman's excellence in hiring practices, ongoing safety and training programs, use of a full-time safety director, claim management, early return to work, and other incentive programs have proven most effective over the years...Your customers, peers, vendors, and employees can be assured that your company aggressively promotes and maintains a strong safety culture."

*— Joseph B. Gillian,
IWIF Workers'
Compensation Insurance*

THE
LINDMAN
DIFFERENCE



- EXPERIENCE
- VALUE
- SERVICE
- SAFETY
- PEACE OF MIND

PEACE OF MIND

What do you look for in your restoration contractor? You look for a contractor who does quality work at fair and equitable prices, a contractor who can provide the full gamut in capabilities and serve as your one-stop shop for all restoration needs. You look for a company whose principals are hands-on and accountable, people who are vested in the outcome of your project. You look for safety.

In other words, you look for a company that offers big-company capabilities and small-company customer care. You look for peace of mind.

Since 1990, we have promised and delivered on just that. We've earned a reputation for treating our customers the way we would want to be treated.

Call us today. Experience for yourself the Lindman Difference.

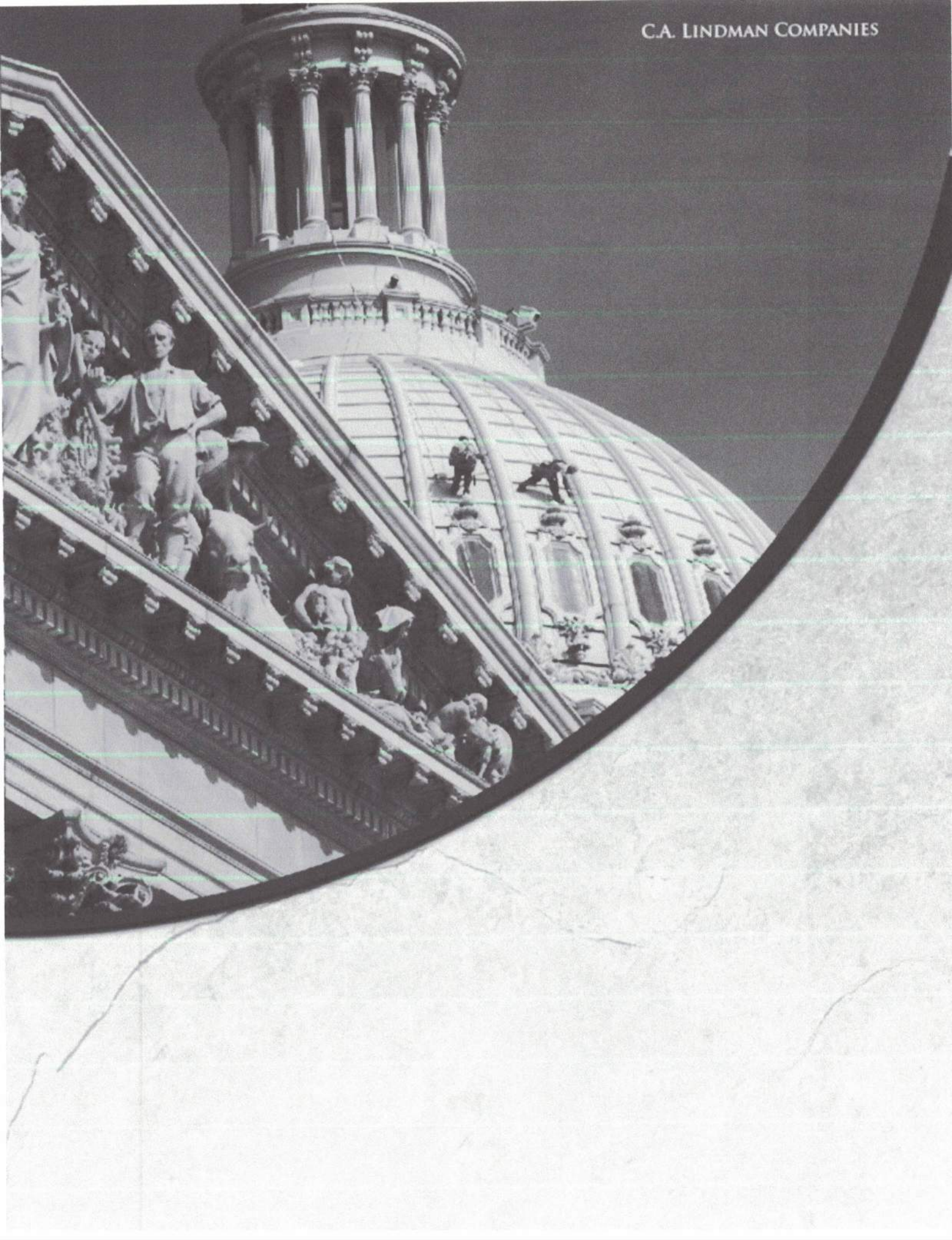

GENERAL CONDITIONS COST

	Item No.	Description	Bid Quantity [A1]	Unit	LUMP SUM WORK
General Conditions I	GC-1	Contractor shall mobilize and demobilize as necessary to perform the entire scope of work.	1	Lump Sum	\$ 295,813.00
	GC-2	Contractor shall be responsible for general conditions including protection of existing building and façade, protection of existing building finishes, weather protection, temporary support, project administration, debris containment, barriers, swing stage rentals, shoring, etc. General conditions are divided equally monthly.	1	Lump Sum	\$ 591,627.62
	GC-3	Contractor shall provide photographic documentation of existing conditions property and all areas that will be affected by construction work (including plaza deck, parking garage, staging areas etc.)	1	Lump Sum	\$ 38,837.00
	GC-4	Contractor shall provide as-built drawings for unit price work performed on each payment application.	1	Lump Sum	\$ 6,213.93
	GC-5	Temporary facilities	1	Lump Sum	\$ 8,000.00
	GC-6	Protection of existing sliding glass doors, swing doors, and window frame systems with self-adhering protective film.	1	Lump Sum	\$ 75,248.25
	GC-7	Contractor to provide shoring engineer drawings to support the structure during all demolition and put back activities in accord with the plans. Designated shoring locations as per engineer's drawings. Structural components requiring shoring such as slabs, walls, beams, etc. identified on engineer's drawings. Shoring post to have a minimum of 5 kip performance. All columns shall be braced prior to any demolition. (Allowance)	1	Lump Sum	\$ 10,000.00
	GC	Subtotal - General Conditions I			\$ 1,026,739.80
General Conditions II	GC-8	Obtain all permits necessary to permit the scope of work (excluding expediting)	1	AT COST	\$ -
	GC-9	Payment and Performance Bond/Labor and Material Bond		%	\$ 140,511.56
	GC-10	Permit Expeditior	1	AT COST	\$ -
	GC	Subtotal - General Conditions II Passthrough Costs			\$ 140,511.56

LUMP SUM WORK COST

	Item No.	Description	Reference	Bid Quantity [A1]	Unit	LUMP SUM WORK
STUCCO PAINT AND SEALANTS	PS-01	EXTERIOR STUCCO PAINT: Repaint the entire exterior of the building in accordance with the specifications. Paint to match existing color and texture. Work to include power wash the entire building, surface preparation on all stucco and concrete, surface conditioner, hot primer, primer, all in accordance with specifications and manufacturer recommendations, and a TWO-COAT paint system. Paint areas includes columns, walls, ceilings, balconies and all other elements at the exterior that are currently painted.	SPEC 99100	1	Lump Sum	\$ 1,217,112.00
	PS-02	BEAUTY BEAD SEALANTS: Total replacement of all secondary "beauty bead" sealant at ALL existing sliding glass doors, swing doors, window frame systems, louvers, and other penetrations.	SPEC 79200 SHEET S4-401	1	Lump Sum	\$ 63,000.00
	PS-03	INTERIOR STUCCO PAINT: Repaint the entire INTERIOR of the building east and west staircases in accordance with the specifications. Paint to match existing color and texture. Work to include power wash, surface preparation on all stucco and concrete, surface conditioner, hot primer, primer, all in accordance with specifications and manufacturer recommendations, and a ONE-COAT paint system. Paint areas includes columns, walls, ceilings, and all other elements at the staircases that are currently painted.	SPEC 99100	1	Lump Sum	\$ 177,080.00
	PS	Subtotal - Stucco Paint and Sealants				\$ 1,457,192.00
TOWER BALCONIES	TB-01	BALCONY TILE REMOVAL. Contractor shall remove and dispose of ALL tile and overburden from approx. four balconies. VIF. Consider 570 SF.	-	1	Lump Sum	\$ 6,840.00
	TB-02	BALCONY WATERPROOFING: Contractor shall remove exiting waterproofing membrane, grind down surface and prepare ALL horizontal balcony decks in accord with manufacture recommendation but no less than a CSP 3 to 5. Contractor shall install UV stable waterproofing assembly WITH A 20 YEAR MANUFACTURER WARRANTY in accord with TT's specifications and manufacturer recommendations. Approx. 12,200 SF VIF	SPEC 71800 SHEET S4-201, S1-202	1	Lump Sum	\$ 390,400.00
	TB-02 ALT	BALCONY WATERPROOFING: Contractor shall remove exiting waterproofing membrane, grind down surface and prepare ALL horizontal balcony decks in accord with manufacture recommendation but no less than a CSP 3 to 5. Contractor shall install UV stable waterproofing assembly WITH A 10 YEAR MANUFACTURER WARRANTY in accord with TT's specifications and manufacturer recommendations. Approx. 12,200 SF VIF	SPEC 71800 SHEET S4-201, S1-202	1	Lump Sum	\$ -

Contractor is solely responsible for estimating quantities of all items listed as Lump Sum

SECTION 00300 - BID FORM
 BASE BID UNIT PRICES AND BID AMOUNTS
 OXFORD TOWERS 50-YEAR ENV.REST REV1
 BID FORM REVISION 1

LUMP SUM WORK COST (CONT)

	Item No.	Description	Reference	Bid Quantity [A1]	Unit	LUMP SUM WORK
TOWER BALCONIES	TB-03	RAILING REPLACEMENT: Remove and replace existing aluminum railing AT ALL BALCONIES with new aluminum railing. Include railing at east/west entrances and pool entrances. Shop drawings by delegated engineer to be provided for review and approval, along with submittal to building department if necessary. Design to be in accordance with FBC Ch. 10 and FBC Ch. 16 requirements. Includes all slab reinforcement bars, sealants and fasteners required for installation of railings. Approx. 3,250 LF. For bidding purposes consider a 2-line, single opening peak-a-boo railing style	SPEC 57230 SHEET S4-201, S1-202	1	Lump Sum	\$ 557,924.00
	TB-04	SHUTTERS REMOVAL: Contractor shall remove all shutters from the entire building. Work to include removal of all embedded anchors. Consider 30% shutter removal for each type of exterior windows and doors.	SHEET S3-104	1	Lump Sum	\$ 10,765.00
	TB	Subtotal - Balcony Waterproofing Paint and Sealants				\$ 965,929.00
TOWER	TW-01	EAST STAIRS FOYER SLAB WATERPROOFING: Contractor shall remove exiting waterproofing membrane, grind down surface and prepare ALL slabs all ALL FLOORS in accord with manufacture recommendation but no less than a CSP 3 to 5. Contractor shall install UV stable traffic coating waterproofing assembly in accord with TT's specifications and manufacturer recommendations.	SPEC 71800 SHEET S1-202, S4-201	1	Lump Sum	\$ 84,250.80
	TW-02	WEST AND EAST STAIRS SLAB WATERPROOFING: Contractor shall remove exiting waterproofing membrane, grind down surface and prepare ALL slabs, stair steps and step risers all ALL FLOORS in accord with manufacture recommendation but no less than a CSP 3 to 5. Contractor shall install traffic coating waterproofing assembly in accord with TT's specifications and manufacturer recommendations.	SPEC 71800 SHEET S1-202, S4-201	1	Lump Sum	\$ 424,947.60
	TW-02 ALT	WEST AND EAST STAIRS SLAB WATERPROOFING Contractor shall remove exiting waterproofing membrane, grind down surface and prepare ALL slabs, stair steps and step risers all ALL FLOORS in accord with manufacture recommendation to receive a concrete stain sealer. 5. Contractor shall install traffic coating in accord with TT's specifications and manufacturer recommendations.	SHEET S1-202	1	Lump Sum	\$ -
	TW-03A	EAST AND WEST STAIRS DOORS REPLACEMENT. Contractor to replace all East Staircase doors and frames at all floors, <u>Foyer door and staircases door</u> . Doors shall be fire rated with a glass panels. Include mechanical arm for all doors. Approx 46 doors. VIF	SHEET S1-202	1	Lump Sum	\$ 252,291.60
	TW-03B	ROOF ACCESS STAIRS DOORS REPLACEMENT. Contractor to replace stair doors accessing the roof, inclusive of new concrete curb and frame. Roof repairs by others. Doors shall be fire rated with a glass panels. Include mechanical arm for all doors. Approx 3 doors, VIF	SHEET S1-202	1	Lump Sum	\$ 18,648.90
	TW-04	EAST ENTRANCE DOOR REPLACEMENT. Contractor to replace EAST entry door and frame with an ADA compliant door. Include mechanical arm. VIF	SHEET S1-202	1	Lump Sum	\$ 5,156.10
	TW-05A	EAST ENTRANCE ROOF REPLACEMENT - Contractor shall remove exiting waterproofing membrane, grind down surface and prepare ALL SURFACES in accord with manufacture recommendation but no less than a CSP 3 to 5. Contractor shall install UV stable waterproofing assembly in WITH A 20 YEAR MANUFACTURER WARRANTY in accord with TT's specifications and manufacturer recommendations	SPEC 71800 SHEETS 3/S1-201 1-2/S4-201	1	Lump Sum	\$ 27,144.00
	TW-05A ALT	EAST ENTRANCE ROOF REPLACEMENT - Contractor shall remove exiting waterproofing membrane, grind down surface and prepare ALL SURFACES in accord with manufacture recommendation but no less than a CSP 3 to 5. Contractor shall install UV stable waterproofing assembly WITH A 10 YEAR MANUFACTURER WARRANTY in accord with TT's specifications and manufacturer recommendations	SPEC 71800 SHEETS 3/S1-201 1-2/S4-201	1	Lump Sum	\$ 26,208.00
	TW-05B	WEST ENTRANCE ROOF REPLACEMENT - Contractor shall remove exiting waterproofing membrane, grind down surface and prepare ALL SURFACES in accord with manufacture recommendation but no less than a CSP 3 to 5. Contractor shall install UV stable waterproofing assembly WITH A 20 YEAR MANUFACTURER WARRANTY in accord with TT's specifications and manufacturer recommendations	SPEC 71800 SHEET 4/S1-202 1-2/S4-201	1	Lump Sum	\$ 28,560.00
	TW-05B ALT	WEST ENTRANCE ROOF REPLACEMENT - Contractor shall remove exiting waterproofing membrane, grind down surface and prepare ALL SURFACES in accord with manufacture recommendation but no less than a CSP 3 to 5. Contractor shall install UV stable waterproofing assembly WITH A 10 YEAR MANUFACTURER WARRANTY in accord with TT's specifications and manufacturer recommendations	SPEC 71800 SHEET 4/S1-202 1-2/S4-201	1	Lump Sum	\$ -
TW-06	CABLE RUNWAYS REPLACEMENT - 6 stacks	S7-101 S7-102	1	ALLOWANCE	\$ 5,000.00	
TW-07	ROOF LEVEL 3 DOOR REPLACEMENT WITH NEW CONCRETE CURB, roof scope/ patching by others	SHEET S1-202	1	Lump Sum	\$ 6,137.00	
TW	Subtotal - Common Areas Lump Sum Work				\$ 939,864.00	

Contractor is solely responsible for estimating quantities of all items listed as Lump Sum

SECTION 06300 - BID FORM
 BASE BID UNIT PRICES AND BID AMOUNTS
 OXFORD TOWERS 50-YEAR ENV.REST REV1
 BID FORM REVISION 1

LUMP SUM WORK COST (CONT)

	Item No.	Description	Reference	Bid Quantity [A1]	Unit	LUMP SUM WORK	
CONCRETE AND STUCCO REPAIRS	CR-01	SLAB EDGE FULL DEPTH. Contractor shall remove and replace 12 inches width of all balconies slab edges in accord with ICR1 guidelines, details and specifications. Assume slab thickness of 4.5 inches. This scope is in preparation for new aluminum railings per TB-03. Work to include new reinforcement bars, replacement of existing deteriorated steel, coating of new and existing exposed steel, surface prep, saw cutting and preformed drip edge, sealants, railing post pocket blockouts, and fasteners required for installation of railings. Approx. 3,250 LF VIF	SPEC 39300 SHEET 1/S3-102	1	Lump Sum	\$	438,750.00
	ST-01	WINDOWS SILL STUCCO REMOVAL - Remove and dispose of 12 inches stucco underneath of all windows extending 6 inches on each side. Install a reinforced cementitious membrane and install a with two-coat wall stucco in accordance with ASTM C926 and TT's details/specifications. Includes all stucco accessories. This is two coat stucco system. Area under windows approx. 1955 SF VIF	SPEC 92400 SHEET 2/S3-104	1	Lump Sum	\$	58,063.50
	TR	Subtotal - Tower Lump Sum Work					\$
Base Bid Lump Sum Total						\$	3,859,798.50

UNIT ITEMS WORK COST

	Item No.	Description	Reference	Bid Quantity [A1]	Unit	UNIT PRICE WORK	
						Unit Price [B1]	Bid Amount [A1 x B1]
HURRICANE, WEATHER WALLS AND MISC. PROTECTION	PR-01	WEATHER WALL - Contractor shall install a temporary wall for weather protection on the interior side of Sliding Glass Doors (Medium and Large Balconies). Wall shall be water tight and resist prescribng wind loads. Work to include shoring below. Consider a 100-inch wide Sliding Glass Door. Delegated Engineer Required	SHEET 1/S3-103	12	EA	\$ 302.40	\$ 3,628.80
	PR-02	WEATHER WALL - Contractor shall install a temporary wall for weather protection on the interior side of Swing Doors (Small Balconies). Wall shall be water tight and resist prescribng wind loads. Work to include shoring below. Consider a 24-inch wide swing door. Delegated Engineer Required.	SHEET 1/S3-103	12	EA	\$ 167.40	\$ 2,008.80
	PR-03	HURRICANE PROVISION Contractor shall demobilize, clean and secure the construction site prior to tropical storms and hurricanes. Contractor to remobilize site when reasonable and safe.	-	1	EA	\$ -	\$ -
	PS	Subtotal - Protection					\$
Concrete Repairs	CR-02	FULL DEPTH OF SLAB. Contractor shall remove and replace spalled concrete in accord with ICR1 guidelines, details and specifications. Assume slab thickness of 6.5 inches. Work to include replacement of deteriorated steel, coating of exposed steel, surface prep and saw cutting.	SPEC 39300 SHEET 2/S3-102	1,750	SF	\$ 147.60	\$ 258,300.00
	CR-03	PARTIAL DEPTH OF SLAB. Contractor shall remove and replace spalled concrete up to 3 inches in depth in accord with ICR1 guidelines, details and specifications. Work to include replacement of deteriorated steel, coating of exposed steel, surface prep and saw cutting.	SPEC 39300 SHEET 2/S3-102	2,200	SF	\$ 81.00	\$ 178,200.00
	CR-04	OVERHEAD PARTIAL DEPTH OF SLAB. Contractor shall remove and replace spalled concrete in accord with ICR1 guidelines, details and specifications. Work to include replacement of deteriorated steel, coating of exposed steel, surface prep and saw cutting. Overhead repair areas shall not exceed 2.5 inches depth and One SF in area.	SPEC 39300 SHEET 2/S3-102	550	SF	\$ 269.10	\$ 148,005.00
	CR-05A	FULL BALCONY REPLACEMENT (UP TO 75 SF): Contractor shall remove and replace spalled concrete from FULL DEPTH OF SLAB in accord with ICR1 guidelines, details and specifications. Assume slab thickness of 4.5 inches. Work to include replacement of deteriorated steel, coating of exposed steel, surface prep and saw cutting.	SPEC 32000, 33000, 39300 SHEETS 1-2/S1-201, 1/S3-103	12	EA	\$ 28,396.25	\$ 340,755.00
	CR-05B	FULL BALCONY REPLACEMENT (UP TO 110 SF): Contractor shall remove and replace spalled concrete from FULL DEPTH OF SLAB in accord with ICR1 guidelines, details and specifications. Assume slab thickness of 4.5 inches. Work to include replacement of deteriorated steel, coating of exposed steel, surface prep and saw cutting.	SPEC 32000, 33000, 39300 SHEETS 5-6/S1-201, 1/S3-103	6	EA	\$ 47,408.00	\$ 284,448.00
	CR-05C	FULL BALCONY REPLACEMENT (UP TO 175 SF): Contractor shall remove and replace spalled concrete from FULL DEPTH OF SLAB in accord with ICR1 guidelines, details and specifications. Assume slab thickness of 4.5 inches. Work to include replacement of deteriorated steel, coating of exposed steel, surface prep and saw cutting.	SPEC 32000, 33000, 39300 SHEETS 3-4/S1-201, 1/S3-103	6	EA	\$ 48,413.60	\$ 290,481.60
	CR-06	WINDOW OVERHEAD PARTIAL DEPTH REPAIR. Contractor shall remove windows to proceed with concrete work, remove and replace spalled concrete in accord with ICR1 guidelines, details and specifications. Work to include replacement of deteriorated steel, coating of exposed steel, surface prep and saw cutting. Includes removal and reinstallation of window. Owner must provide window's information and NOA, and evidence of permitting records.	SPEC 39300 SHEET 3/S3-104	25	CF	\$ 2,478.60	\$ 61,965.00
	CR-07	CONCRETE COLUMNS: Contractor shall remove and replace spalled concrete in accord with ICR1 guidelines, details and specifications. Work to include replacement of deteriorated steel, coating of exposed steel, surface prep and saw cutting.	SPEC 39300 SHEET 3/S3-102	250	CF	\$ 428.40	\$ 107,100.00

Contractor is solely responsible for estimating quantities of all items listed as Lump Sum

SECTION 06300 - BID FORM
 BASE BID UNIT PRICES AND BID AMOUNTS
 OXFORD TOWERS 50-YEAR ENV.REST REV1
 BID FORM REVISION 1

UNIT ITEMS WORK COST (CONT)

	Item No.	Description	Reference	Bid Quantity [A1]	Unit	UNIT PRICE WORK	
						Unit Price [B1]	Bid Amount [A1 x B1]
Concrete Repairs	CR-08A	STRUCTURAL CRACKS wider than 1/4". Epoxy inject cracks in structural concrete (with SIKADUR 31 HI-MOD GEL Cap Seal and SIKADUR 35, HI-MOD LV Epoxy Resin). Repairs per details and specifications.	SPEC 39300 SHEET S3-101	100	LF	\$ 83.00	\$ 8,300.00
	CR-08B	STRUCTURAL CRACKS wider than .004" and less than 1/4". Epoxy inject cracks in structural concrete (with SIKADUR 31 HI-MOD GEL Cap Seal and SIKADUR 35, HI-MOD LV Epoxy Resin). Repairs per details and specifications.	SPEC 39300 SHEET S3-101	100	LF	\$ 83.00	\$ 8,300.00
	CR-09	METAL INCLUSIONS :Misc. corroded foreign ferrous metal objects to be removed and replaced in accordance with ICRI guidelines, details and specifications. Shuttle's r anchors removal included on line item TB-04	SPEC 39250 SHEET 5/S3-101	1,000	EA	\$ 27.90	\$ 27,900.00
	CR-10A	WINDOW SILL REPLACEMENT (Type B/D) - Precast window sill 4"by 8" removal and replacement . Sill extends 4-inches past window opening on both sides. Consider a 50-inch wide window. Includes removal and reinstallation of window. Owner must provide window's information and NOA, and evidence of permitting records.	SHEET 1-2/S3-104	80	EA	\$ 80.00	\$ 6,400.00
	CR-10B	WINDOW SILL REPLACEMENT (Type A) - Precast window sill 4"by 8" removal and replacement . Sill extends 4-inches past window opening on both sides. Consider a 75-inch wide window. Includes removal and reinstallation of window. Owner must provide window's information and NOA, and evidence of permitting records.	SHEET 1-2/S3-104	10	EA	\$ 361.40	\$ 3,614.00
	CR-10C	WINDOW SILL REPLACEMENT (Type C) - Precast window sill 4"by 8" removal and replacement . Sill extends 4-inches past window opening on both sides. Consider a 25-inch wide window. Includes removal and reinstallation of window. Owner must provide window's information and NOA, and evidence of permitting records.	SHEET 1-2/S3-104	4	EA	\$ 352.00	\$ 1,408.00
	CR-11	CONCRETE TESTING: Provide third party concrete core testing for chlorides content and compression strenght	SPEC 014500	20	EA	\$ 822.00	\$ 16,440.00
	CR-12	BREEZE WALL REPLACEMENT: Replace deteriorated breeze wall, to match existing. Include cementitious waterproofing on entire opening, with 8 inches return to the inside and outside walls. Consider each opening of 28x90 inches, or 28 pieces per opening. (Allowance)	S7-102	5	EA	\$ 2,500.00	\$ 12,500.00
	CR Subtotal - Concrete Repairs					\$	1,754,116.60
Stucco Repairs	ST-02	OVERHEAD SOFFIT STUCCO: Contractor shall remove and dispose of delaminated and/or damaged overhead soffit stucco. Contractor shall replace one-lift soffit stucco in accord with ASTM C926 and details/specifications. StoQuick Gold Soffit System preferred.	SPEC 92400 SHEET 7/S4-101	5,500	SF	\$ 35.00	\$ 192,500.00
	ST-03A	VERTICAL STUCCO: Contractor shall remove and dispose of delaminated and/or damaged vertical stucco on the lower envelope and balconies. Contractor shall replace two-lift wall stucco in accord with ASTM C926, details and specifications, including tuck-pointing. This is a two coat stucco.	SPEC 92400 SHEET 8/S4-101	10,800	SF	\$ 29.00	\$ 313,200.00
	ST-03B	VERTICAL STUCCO WITH BUILDOUT: Contractor shall remove and dispose of delaminated and/or damaged vertical wall stucco on the lower envelope and balconies. Contractor shall buildout and plumb misaligned substrate (assume 1" thickness) to insure stucco thickness does not exceed 5/8" section 039250. Contractor to replace two-lift wall stucco in accord with ASTM C926, details and specifications.	SPEC 39250 SHEET 9/S4-101 SPEC 92400 SHEET 9/S4-101	2,160	SF	\$ 41.00	\$ 88,560.00
	ST-04	SUBSTRATE JOINTS: Contractor shall install 8" wide plastic lath strips at all joints of dissimilar materials in accord with ASTM C926, details and specifications. Contractor to include tuck pointing and stainless steel fasteners	SPEC 92400 SHEET 4/S4-101	6,750	LF	\$ 8.00	\$ 54,000.00
	ST-05	PARAPET RIBBON WALL: Contractor to install Sto RFP mesh stucco system on parapet exterior wall ribbon and underside ceiling in accord with ASTM C926. Include Sto Prime. Include stucco.	SPEC 92400 SHEET 8/S4-101	3,500	SF	\$ 32.80	\$ 114,800.00
		ST Subtotal - Stucco Repairs					\$
Masonry Details	MR-01	MASONRY TUCK-POINTING REPAIRS: Repair deteriorated masonry components in accordance with TMS/ICRI guidelines, details and specifications. Work to include tuck-point between masonry runs, and at masonry/concrete transitions	SPEC 42200 SHEET 4/S3-301	1,500	LF	\$ 32.00	\$ 48,000.00
	MR-02	MASONRY FACE REPAIRS: Repair deteriorated masonry components in accordance with TMS/ICRI guidelines, details and specifications. Work to include gel patching of block face. Consider a blocks'cell width of 8 inches.	SPEC 42200 SHEET 4/S3-301	200	EA	\$ 119.00	\$ 23,800.00
	MR-03	MASONRY FILLED CELLS REPAIRS: Repair deteriorated masonry components in accordance with TMS/ICRI guidelines, details and specifications. Work to include replacement of deteriorated/missing steel, coating of exposed steel, surface prep, saw cutting, and grouting of empty cells. Consider a blocks'cell width of 8 inches.	SPEC 42200 SHEET 4/S3-301	200	EA	\$ 112.00	\$ 22,400.00
		MR Subtotal - Masonry Repairs					\$
	Base Bid Unit Price Total					\$	2,617,014.20

Contractor is solely responsible for estimating quantities of all items listed as Lump Sum

SECTION 00300 - BID FORM
 BASE BID UNIT PRICES AND BID AMOUNTS
 OXFORD TOWERS 50-YEAR ENV.REST REV1
 BID FORM REVISION 1

BID COST SUMMARY

General Conditions I	\$	1,025,739.80
General Conditions II Passthrough Costs	\$	140,511.56
Base Bid Lump SumTotal	\$	3,859,798.50
Base Bid Unit Price Total	\$	2,617,014.20
Total Bid Price Estimate	\$	7,643,064.06

HURRICANES AND NAMED STORMS

	ITEM NO.	DESCRIPTION	Bid Quantity [A1]	PRICE	Unit
HURRICANES	H1	Hurricane Demobilization/Mobilization - Provide itemization of costs.	Each Occurrence	\$ -	LS
	H2	Hurricane Demobilization - Provide estimated duration to demobilize the site in preparation for a hurricane.			DAYS
	H3	Hurricane ReMobilization - Provide estimated duration to remobilize the site.			DAYS

CONTRACT TIME DURATION	\$	780.00
Time/Material/Equipment Cost Plus		20%

* NOTE: Any deviations from specified products must be specifically stated in the bid
 ** NOTE: Contractor to create mock-ups and receive written approval architect / engineer prior to the purchasing of materials for scope of work

Contractor is solely responsible for estimating quantities of all items listed as Lump Sum

Clarifications and Qualifications

CA Lindman of South Florida LLC

1. Due to changes in the raw materials market and the supply chain challenges, C.A. Lindman can only hold its material price from the date of this proposal for a maximum of 30 days. (Please note even with this hold there is no absolute assurance of material availability as a part of the proposal.)
2. In order to have the best opportunity to obtain the material prices used in the proposal C.A. Lindman must be under contract within 30 days with the goal that materials will be purchased at the quoted prices and stored pending use on the project within no later than 45 days of contract.
3. The Owner should be prepared to pay for all stored material at the beginning of the project and reached a shared understanding as to the location the materials will be stored - be it jobsite or C.A. Lindman's warehouse or to another mutually agreeable location.
4. For materials that cannot be purchased or stored, changes in raw material and supply chain challenges will remain a risk to the Owner and be subject to a change order.
5. Unless otherwise indicated, this proposal is based on performing all work during regular working hours of working days.
6. The proposal is based upon C.A. Lindman's (CAL's) full access to work areas and the ability to restrict non-project persons or vehicles from work areas. Public access through work areas is NOT included unless specifically identified in the project scope.
7. CAL's proposal assumes the ability to store materials and equipment on property at location proximate to work area.
8. For façade repair projects, all parked vehicles below work areas must be removed and vehicle/pedestrian traffic below the work areas must be restricted for a safe distance out from the base of the building. Where necessary, CA Lindman will erect perimeter barriers to maintain grade level safety zone.
9. When swing stage(s) is/are in place in front of terraces or balcony tier(s), for safety reasons all resident access onto all terraces and balconies in the affected tiers must be restricted for the entire time swing stages are in place.
10. If work scope or Engineer's direction requires Contractor's repair technicians to enter privately-owned residential units, the Owner or its agent(s) are responsible to provide a security escort for CAL's employees to enter privately-owned residential units.
11. The proposal is based on CAL's use of building water and electricity utilities at no cost to CAL.
12. The proposal is based on CAL being able to receive payment for large-cost items (rails, windows/sliding glass doors, etc.) delivered and stored on site or off site (CA Lindman insurance does cover materials stored off site).
13. This proposal includes allowance of time for CA Lindman to operate swing stage for Engineer's markup of repair areas and for Engineer's inspection of repairs in progress/when complete. In general, four inspections are anticipated for each vertical tier of work locations. Excessive or inefficient inspection may require additional cost for non-productive time.

14. Detail planning of project logistics is not performed until after a project is contracted. In some instances, impact to adjacent property(ies) may be necessary for egress, equipment set up or safety precautions. CA Lindman will not negotiate with adjacent property owners. Any necessary impact to adjacent properties to the benefit of the project in question must be arranged between client property's Owner(s) and/or management.
15. The proposal does NOT include removal or re-routing of drains, sprinkler lines, electrical conduit or other utility lines which interfere with work. If any such cases occur, cost for rerouting would be at an additional cost and may require additional time added to the contract schedule which may need to be performed on a time and material basis at an additional cost.
16. Work tasks identified on project bid form to be Lump Sum will be billed incrementally as work is performed, but eventually will be billed and must be paid at the full amount stated on bid form.
17. This proposal does not include replacement of any grass or landscaping affected as part of this project, unless due to gross negligence by CAL. CAL will work with property management prior to start of project to identify any trees or landscaping which may need to be trimmed or removed to allow access to perform work. Concrete dust may be harmful to landscaping, so Owners' landscape contractor should be tasked with maintenance and if necessary cleaning/washing of all existing plants while this project is being performed. If access to work areas involves repair crews walking on property grass, sod may need to be placed in affected areas at completion of project. We do NOT carry any \$ for such lawn or landscaping restoration.
18. In the event of a hurricane or other severe weather event during performance of this project, C.A. Lindman's standard hurricane policy would be in force. All costs to demobilize/remobilize or otherwise protect and secure the work site from adverse effects of a hurricane or other severe weather event would be at ADD to the contract at CAL's standard Time and Material rates. Project duration would also be extended by equal number of days by which project progress is lost due to demobilization/storm/remobilization.
19. Hazardous waste removal and/or asbestos surveys are excluded from the proposal.
20. Material warranties are as provided by specified material manufacturers.
21. C.A. Lindman's standard labor/workmanship warranty of 5 year is included and commences after the earlier of Substantial Completion or Beneficial Use.
22. Cost for any type of security for the building or management is NOT included.
23. Permit fees are a direct cost to Owner, and will include the cost of a permit expediter.
24. If increase in Actual repair quantities beyond Allowance repair quantities causes increases in total repair quantities value of more than 10% (ex-if original repair quantities value \$1 million increases to \$1.1 million), General Conditions costs would then be subject to increase. Gen Conds increase may not be proportional to total contract amount increase.
25. Unless identified as a Unit cost, repair of damaged/failed post-tension reinforcement is an additional cost on a time and material basis and may result in additional time added to the contract schedule.
26. C.A. Lindman's proposal is based upon the use of a CAL standard proposal format or standard AIA A104 (2017) format contract. Review and/or use of an alternate contract format may result in an additional cost. Some administrative or procedural activities stipulated by project manual

may be subject to review, discussion and possible modification as part of any mutually-agreeable contract.

27. Unless terms of liquidated damages are expressly stated as a condition of the project bid, we do not include acceptance of LDs as a part of our price/term of any contract agreement. If Owners insist on LDs as a condition of a contract, the proposed price and/or schedule duration may be subject to adjustment to address the increased risk.
28. For projects involving furnishing/installation of new balcony, walkway or plaza rails, warranty of rail paint finish, including paint applicator's requirements for washing/maintenance of rails to maintain warranty, is a direct pass-through from rail manufacturer to Owner. C.A. Lindman will not be responsible for rail paint finish beyond its 1 year new-installation warranty. With regard to the rails, in the event of any conflict between warranty requirements of the project specification and rail manufacturer's offered warranty, rail manufacturer's offered warranty shall take precedence.
29. For projects with expansion joint work, C.A. Lindman's proposal does not include modifications of existing joint edge conditions or slab edge configuration to suit new joint system unless expressly identified in CAL's proposal, even if specified or noted on drawings.
30. Stucco pricing is based on demo/buildback of 5/8" thick stucco in conformance with Florida Building Code. If stucco is found to be thicker, add cost would be required for thicker demo and for application of structural build-out material to limit replacement stucco to maximum 5/8" thick. Add cost would vary by required thickness.
31. All repair pricing is based on minimum charge per repair location of one (1) unit for work measured as Per SF or Per LF, and for minimum ¼ CuFt for that work tasks measured per Cu Ft. Payment based on measurement of less than 1 full unit is not acceptable.
32. For all contracts greater than \$2.499,000 as initial value, due to change order or due to Allowance Quantity repair quantity overruns, Owner may withhold 10% of payments earned as retainage until the project is 50% complete by billing. Owner shall continue to hold that amount withheld until the project reaches Substantial Completion. However, after the project passes the 50% completion point, because Owners' risk declines as the project gets progressively nearer to completion, no additional retainage would be withheld. Retainage withheld would be included and paid as part of Final Payment following Substantial Completion.
33. This proposal is based on C.A. Lindman's standard insurance coverage. See sample Cert for Insurance for included coverages.
34. If performance and payment bonds are required, this proposal is based on providing CA Lindman standard bond language. Specific to Payment Bond, CA Lindman will provide a Conditional Payment Bond in conformance with Florida Statute 713.245 (see samples attached). Should the Owner require alternative language or terms which modifies C.A. Lindman's surety's standard language or Florida statute 713.245, CA Lindman would need approval/agreement with our long time insurer and/or bonding company, verification of project funding from Owners and additional cost will be required.
35. Performance and Payment bonds will remain in effect for one year after project Substantial Completion. Any need for bond coverage beyond one year would require Owners to purchase Maintenance bond(s) at additional cost.

36. This bid is based on issuance of CA Lindman standard warranty form and on standard warranty forms of subcontractors and/or specified/approved material suppliers. CA Lindman does not assume any obligation to sign any other warranty form proposed by Owner/Owner's attorney. All warranties are expressly conditioned upon Owner's payment in full of all money owed for the project and no warranty would be in effect until CAL's receipt of final payment in full. Warranty duration would start from date of project Substantial Completion or Beneficial Use regardless of date of final payment.
37. Shoring during Construction is based as allowance.
38. For removal of window only included removal of window only does not include removal of finishes or put back of new finishes. Stucco R/R not included in this line item. Sealant is part of paint line item.
39. Hurricane price is based as a T&M rate of \$95.00 per man per hour and material at cost plus 20%
40. Full balcony replacement railing removal is not included in balcony replacement.
41. For Full demo is prices using 25 lbs hammers.
42. GC-7 and GR-12 based as an allowance price can +/-.
43. Hurricane is based as T & M price of \$95.00 per man per hour and material cost at cost plus 20%.



CERTIFICATE OF LIABILITY INSURANCE

DATE (MM/DD/YYYY)

3/21/2024

THIS CERTIFICATE IS ISSUED AS A MATTER OF INFORMATION ONLY AND CONFERS NO RIGHTS UPON THE CERTIFICATE HOLDER. THIS CERTIFICATE DOES NOT AFFIRMATIVELY OR NEGATIVELY AMEND, EXTEND OR ALTER THE COVERAGE AFFORDED BY THE POLICIES BELOW. THIS CERTIFICATE OF INSURANCE DOES NOT CONSTITUTE A CONTRACT BETWEEN THE ISSUING INSURER(S), AUTHORIZED REPRESENTATIVE OR PRODUCER, AND THE CERTIFICATE HOLDER.

IMPORTANT: If the certificate holder is an ADDITIONAL INSURED, the policy(ies) must have ADDITIONAL INSURED provisions or be endorsed. If SUBROGATION IS WAIVED, subject to the terms and conditions of the policy, certain policies may require an endorsement. A statement on this certificate does not confer rights to the certificate holder in lieu of such endorsement(s).

PRODUCER Consolidated Insurance + Risk Management 11403 Cronridge Drive, Ste 270 Owings Mills MD 21117	CONTACT NAME: Insurance Certificate Team	
	PHONE (A/C, No, Ext): 410-356-9500	FAX (A/C, No): 410-363-3520
E-MAIL ADDRESS: coijd@consolidatedinsurance.com		
INSURER(S) AFFORDING COVERAGE		NAIC #
INSURER A: Indian Harbor Insurance Company		36940
INSURER B: Monroe Guaranty Insurance Co.		32506
INSURER C: Gray Surplus Lines Insurance Company		15889
INSURER D: Chesapeake Employers Insurance		11039
INSURER E: American Zurich Insurance Co		40142
INSURER F: Starstone Specialty Insurance Company		44776

COVERAGES **CERTIFICATE NUMBER:** 1091295081 **REVISION NUMBER:**

THIS IS TO CERTIFY THAT THE POLICIES OF INSURANCE LISTED BELOW HAVE BEEN ISSUED TO THE INSURED NAMED ABOVE FOR THE POLICY PERIOD INDICATED. NOTWITHSTANDING ANY REQUIREMENT, TERM OR CONDITION OF ANY CONTRACT OR OTHER DOCUMENT WITH RESPECT TO WHICH THIS CERTIFICATE MAY BE ISSUED OR MAY PERTAIN, THE INSURANCE AFFORDED BY THE POLICIES DESCRIBED HEREIN IS SUBJECT TO ALL THE TERMS, EXCLUSIONS AND CONDITIONS OF SUCH POLICIES. LIMITS SHOWN MAY HAVE BEEN REDUCED BY PAID CLAIMS.

INSR LTR	TYPE OF INSURANCE	ADDL INSD	SUBR WVD	POLICY NUMBER	POLICY EFF (MM/DD/YYYY)	POLICY EXP (MM/DD/YYYY)	LIMITS
A	<input checked="" type="checkbox"/> COMMERCIAL GENERAL LIABILITY <input type="checkbox"/> CLAIMS-MADE <input checked="" type="checkbox"/> OCCUR GEN'L AGGREGATE LIMIT APPLIES PER: <input type="checkbox"/> POLICY <input checked="" type="checkbox"/> PROJECT <input type="checkbox"/> LOC OTHER:	Y	Y	ESG0065114	2/1/2024	2/1/2025	EACH OCCURRENCE \$ 1,000,000 DAMAGE TO RENTED PREMISES (Ea occurrence) \$ 500,000 MED EXP (Any one person) \$ 10,000 PERSONAL & ADV INJURY \$ 1,000,000 GENERAL AGGREGATE \$ 2,000,000 PRODUCTS - COMP/OP AGG \$ 2,000,000 Emp Ben \$ 1,000,000
B	<input checked="" type="checkbox"/> AUTOMOBILE LIABILITY <input checked="" type="checkbox"/> ANY AUTO <input type="checkbox"/> OWNED AUTOS ONLY <input type="checkbox"/> SCHEDULED AUTOS NON-OWNED AUTOS ONLY <input checked="" type="checkbox"/> HIRED AUTOS ONLY	Y	Y	CA 100090042	2/1/2024	2/1/2025	COMBINED SINGLE LIMIT (Ea accident) \$ 1,000,000 BODILY INJURY (Per person) \$ BODILY INJURY (Per accident) \$ PROPERTY DAMAGE (Per accident) \$ \$
C	<input type="checkbox"/> UMBRELLA LIAB <input checked="" type="checkbox"/> OCCUR <input checked="" type="checkbox"/> EXCESS LIAB <input type="checkbox"/> CLAIMS-MADE <input type="checkbox"/> DED <input checked="" type="checkbox"/> RETENTION \$ 0			GSL101919	2/1/2024	2/1/2025	EACH OCCURRENCE \$ 5,000,000 AGGREGATE \$ 5,000,000 \$
D E	WORKERS COMPENSATION AND EMPLOYERS' LIABILITY ANY PROPRIETOR/PARTNER/EXECUTIVE OFFICER/MEMBER EXCLUDED? (Mandatory in NH) If yes, describe under DESCRIPTION OF OPERATIONS below	Y/N N	N/A	8011343 WC 0758290-02	2/1/2024 2/1/2024	2/1/2025 2/1/2025	<input checked="" type="checkbox"/> PER STATUTE <input type="checkbox"/> OTH-ER E.L. EACH ACCIDENT \$ 1,000,000 E.L. DISEASE - EA EMPLOYEE \$ 1,000,000 E.L. DISEASE - POLICY LIMIT \$ 1,000,000
B F B	Installation Floater Pollution Property - Special - Inc. Theft			CPP 100090040 O86934241AEM CP 100090041	2/1/2024 2/1/2024 2/1/2024	2/1/2025 2/1/2025 2/1/2025	Jobsite/Disaster 4,000,000 Occ/Agg 1,000,000 BPP 590,000

DESCRIPTION OF OPERATIONS / LOCATIONS / VEHICLES (ACORD 101, Additional Remarks Schedule, may be attached if more space is required)

CERTIFICATE HOLDER **CANCELLATION**

Proof of Insurance	SHOULD ANY OF THE ABOVE DESCRIBED POLICIES BE CANCELLED BEFORE THE EXPIRATION DATE THEREOF, NOTICE WILL BE DELIVERED IN ACCORDANCE WITH THE POLICY PROVISIONS.
	AUTHORIZED REPRESENTATIVE 

© 1988-2015 ACORD CORPORATION. All rights reserved.

Ron DeSantis, Governor



Melanie S. Griffin, Secretary



**STATE OF FLORIDA
DEPARTMENT OF BUSINESS AND PROFESSIONAL REGULATION**

CONSTRUCTION INDUSTRY LICENSING BOARD

THE GENERAL CONTRACTOR HEREIN IS CERTIFIED UNDER THE
PROVISIONS OF CHAPTER 489, FLORIDA STATUTES



PUSHECK, ROBERT GEORGE
CALLIDMAN OF SOUTH FLORIDA-III
10401 GULFORD ROAD
JESSUP MD 20794

LICENSE NUMBER: CGC1917124

EXPIRATION DATE: AUGUST 31, 2024

Always verify licenses online at MyFloridaLicense.com



Do not alter this document in any form.

This is your license. It is unlawful for anyone other than the licensee to use this document.



May 17, 2023

PROPOSAL# 23-085

PROPOSAL/CONTRACT

Oxford Towers Condominium Assoc, Inc
C/o: Board of Directors
1501 South Ocean Drive
Hollywood, FL 33019

RE: Oxford Towers Condominium Envelope Restoration.

Restore Construction Group, Inc. ("Contractor"), a Florida Corporation, submits the proposed Contract to **Oxford Towers Condo Assoc, Inc** ("Customer") at **980 1501 South Ocean Drive Hollywood, FL 33019** to perform services and to provide services described under "Scope of Work" below ("the Work") Restore Construction Group, Inc. will provide the following:

SCOPE OF WORK

- Mobilize project to perform referenced Scope of Work including all necessary materials, tools, equipment, protection, labor and supervision.
- All work to be performed per **Thornton Tomasetti** Specifications dated **March 23, 2023** of the **Two-Hundred and Fifty-Nine (259) Page** inspection -engineering- construction document with **Thirty-Eight (38) Drawings**.
- Demobilize and clean work area.

PRICE

See attached bid form

NOTE: If proposal is itemized for your review, values are based on performing all items as one project. If any one item is rejected, all pricing will be subject to change.

ENGINEERING AND PERMIT FEES

Any and all engineering and permit fees will be the responsibility of the Owner.

PAYMENT TERMS

We require Mobilization, Permits, General Condition and Bond Fees upon Contract signing. A 30% material deposit including paint is due on all specialty order items. Progress payments are due as invoiced and the balance due upon completion. If payment is not received in the allotted time frame, a 1.5% monthly late fee will apply until paid.

CONTRACTORS PROVISIONS

The following provisions shall be considered as part of our bid proposal and take priority over any language in the bid documents that deviate from these conditions. For repair items in bid list where repair pricing is requested on a "unit of measure" basis, the following applies unless otherwise specified in the engineer's specifications:

- Partial deck repair; includes up to a maximum 3" depth.
- Overhead repair; includes up to a maximum 3" depth.
- Edge repair; includes up to a maximum of 8" back into slab.
- Column/ wall / beam repairs; includes up to a maximum 3" depth.
- Stucco replacement; includes up to a maximum 3/4" depth repair.

As per EPA Guidelines, this contractor is obligated to test any surfaces in the work area for lead. Should the testing come back positive for lead or any other harmful contaminants, the cost of remedial work is not included in this proposal.

If Applicable: Please note that the unit prices are based upon estimated quantities which could vary significantly plus or minus, except Lump Sum Items. Concrete repair is to be performed in accordance with ICRI standards and recommendations. Restore Construction Group, Inc. cannot be held responsible for any items broken or damaged due to vibration or any water intrusions. The owner is to provide water and electric at no cost to the Contractor. The Contractor will not be responsible for any roof damages, landscaping located under or around the work area, asphalt parking area, sliding glass doors, window screens, vertical blinds or any type of window systems. The owner will remove any personal property and vehicles out of the work area before work commences. Restore Construction Group, Inc. will not be held responsible for interior damage, any floor coverings such as tile, carpet, etc., that may be damaged as a result of the work. Please note Restore Construction Group, Inc. will only be held responsible for negligent damages for the items outlined above. All permits (Right of Way, Maintenance of Traffic, including overhead protection and parking meters, and Building) will be billed at cost + \$800.00 expediting fee + 20% margin per permit.

The Engineer will determine negligent damages. Please take note that the Engineer will perform inspections on all phases of the work and any possible damages deemed "negligent" will need to be addressed in the written inspection reports documented by the project Engineer. If the items were not previously documented as negligent damage in the Engineering reports, then the items will be considered non negligent damages. Restore cannot be held responsible for any utilities damaged due to buried or embedded lines, connections or junctions. The contract amount will be based upon unit cost indicated for the actual amount of concrete repair performed. Lump sum and unit cost bids shall include all material, labor, equipment, shoring, scaffolding, and clean-up, unless it is specifically identified otherwise, by issuing separate pricing for the above-mentioned items. In the event of a discrepancy between the amount shown in both words and in figures above, the amount shown in words shall govern. If the Contract is terminated for Owners breach of non-payment, the Owner cannot file any type of claim against the surety. Please also note, in the event of a conflict between these provisions and any other contract document, this document shall govern above all others. Owners to provide any touch-up paint as necessary at no cost to the Contractor.

WARRANTY PROVISIONS

We will provide any manufacturer warranties of the products we install where offered. In most cases small repairs are not offered a warranty by either the manufacturer or Restore Construction Group, Inc. The maximum limit of our warranty for performance on concrete repair and stucco painting is five (5) years from date of completion. The painting of any metal surfaces warranty by Restore Construction Group, Inc. is one (1) year from date of completion. Floor Coatings will have a one-year warranty, unless otherwise specified. The Warranty is contingent upon the Owner making payments in accordance with the agreement. The surety will cover the Warranty for a period of one-year maximum.

TIME TO COMPLETE

We propose to be substantially complete within **THREE-HUNDRED AND FORTY (340) CALENDAR DAYS** and achieve final completion **THIRTY (30) CALENDAR DAYS** later. Please note if the quantities outlined in the scope of work increase, then additional time will be required to complete the project.



CHAPTER 558 NOTICE OF CLAIM

CHAPTER 558, FLORIDA STATUTES, CONTAINS IMPORTANT REQUIREMENTS YOU MUST FOLLOW BEFORE YOU MAY BRING ANY LEGAL ACTION FOR AN ALLEGED CONSTRUCTION DEFECT. SIXTY DAYS BEFORE YOU BRING ANY LEGAL ACTION, YOU MUST DELIVER TO THE OTHER PARTY TO THIS CONTRACT A WRITTEN NOTICE, REFERRING TO CHAPTER 558, OF ANY CONSTRUCTION

CONDITIONS YOU ALLEGE ARE DEFECTIVE AND PROVIDE SUCH PERSON THE OPPORTUNITY TO INSPECT THE ALLEGED CONSTRUCTION DEFECTS AND TO CONSIDER MAKING AN OFFER TO REPAIR OR PAY FOR THE ALLEGED

CONSTRUCTION DEFECTS. YOU ARE NOT OBLIGATED TO ACCEPT ANY OFFER WHICH MAY BE MADE. THERE ARE STRICT DEADLINES AND PROCEDURES UNDER THIS FLORIDA LAW WHICH MUST BE MET AND FOLLOWED TO PROTECT YOUR INTERESTS.

LICENSING AND INSURANCE

We are a State Certified Licensed General Contractor and carry liability coverage and complete Workman's Compensation Insurance, as required by law.

This proposal will be automatically withdrawn if not accepted within thirty (30) days. If you have any questions, please do not hesitate to contact this office and we shall respond accordingly.

As Agreed, Upon By:

Alain Espinosa
Restore Construction Group, Inc.

May 17, 2023
Date

Oxford Towers Condo Assoc, Inc

Date

5 YEAR WARRANTY

[DATE]

[PROJECT NAME]

[PROJECT ADDRESS]

Restore Construction Group, Inc. ("RCG") warrants the concrete restoration, painting of masonry and any waterproofing work performed by it under the contract signed by [PROJECT NAME] for [TYPE OF WORK], on [CONTRACT DATE] is free from defects in installation and workmanship under conditions of ordinary wear, for a period of (5) five years from the date of this letter. The warranty for the painting of any metal surfaces or touch up painting is for a period of (1) one year from the date of this letter. To make a claim under this warranty, you must provide written notice of the claim to RCG within the applicable warranty period, which notice must be delivered by hand delivery, or mailed by United States Certified Mail, Return Receipt Requested, postage prepaid within seven (7) days of discovery of the circumstance giving rise to the warranty claim ("Notice"), time being of the essence. Upon receipt of your timely written warranty claim, RCG will schedule an inspection for the purpose of verifying your warranty claim. This Warranty includes all labor and materials required to perform repairs of proven defects in material, installation and workmanship under conditions of ordinary wear.

Any Defective Work and materials verified by RCG will be corrected at no cost to you. Should RCG fail or refuse, due to its own fault, to commence and continue to correct such verified Defective Work and materials, if any, within twenty (20) days from the date of the above-referenced inspection, you may, upon ten (10) additional days written Notice and time to cure, pursue legal action to enforce this warranty.

Additionally, it is specifically acknowledged, understood and agreed that additional considerations are necessitated due to the current Supply Chain Crisis and COVID pandemic; including, without limitation, governmental and quasi-governmental agencies delays; suspensions and interruptions of work and/or services that are in place or scheduled; as well as the restrictions on the working environment, construction means and methods; material shortages, and delays; and size and proximity of work forces and worker productivity that are expected to continue as a result thereof. Accordingly, should the current Supply Chain Crisis, COVID pandemic, or any other pandemic(s), viruses, variant, declared National, State and/or Local Emergencies, supply chain issues impact RCG's ability to perform under this Warranty, RCG shall be entitled to an increase in the Time to so perform (without any charge to you).

RCG will not under any circumstances be responsible for damages which are caused by: acts of God; abnormal or abusive use and wear; building alterations repairs, alterations, testing, damage or destruction by anyone other than RCG; or failure by Owner or its agents, employees or contractors to follow any recommended or industry standard maintenance or cleaning procedures.



Any work, repairs, alterations, testing, damage or destruction of or to any repaired area by someone other than RCG shall void this warranty as to that repaired area. RCG will not be held responsible for incidental, special or consequential damages with respect to the installation and workmanship covered by this warranty, including but not limited to loss of use of premises while repairs are being done, which includes any source of income loss, time loss, and inconvenience created by repairs covered under a warranty claim. Please note that if there are any due and owing monies that were not paid and left pending that this warranty will be voided.

When performing repairs of proven defects in installation and workmanship under this warranty, RCG reserves the right to replace such material with commercially reasonable substitute material. Any claim against this warranty is contingent upon proper Notice and full payment for all work performed.

We are confident in our work and do not expect you will have to call upon a warranty repair. If we can be of any assistance to you, please do not hesitate to contact us.

Sincerely,

Restore Construction Group, Inc.

Oxford Towers 50-Yr Recertification Repairs

March 23, 2023

BID PROPOSAL FORMName of Bidder Restore Construction Group, IncAddress 2411 S.W. 58th Ter West Park, FL 33023Telephone Number (P) 954-985-5353 (F) 954-985-5356**PROPOSAL FOR THE**

The Oxford Towers Condominium Porte Cochere Replacement

OWNER**Oxford Towers Condominium Association, Inc**

1501 South Ocean Drive, Hollywood, FL 33019

Contact: PROPERTY MANAGER

ENGINEER

Thornton Tomasetti

101 NE Third Avenue, Suite 1170

Fort Lauderdale, FL 33301

tel: 954.903.9300

Contact: Hector Guerra P.E. AND Vanessa Da Rocha, AIA

To Whom It May Concern:

The undersigned, having fully examined the Scope of Work and having examined the premises and familiarized themselves with conditions likely to be encountered affecting the cost and schedule, makes the following proposal to provide all labor, materials, equipment and services required to perform and complete the Work in accordance with the Scope of Work document.

Oxford Towers 50-Yr Recertification Repairs

March 23, 2023

BASE BID

We agree to perform and complete all Work described in the Drawings and Project Specifications and any Addenda which may be issued thereto during the bidding period; and, if this proposal is accepted, will execute a formal contract in the form that is bound into the Project Manual, to this effect, for the LUMP SUM price of

Five-Million Seven-Hundred Seven-ThousandTwo Dollars and Sixty-Eight Cents

1. _____ DOLLARS (\$ 5,707,002.68 _____.)

It is understood that the work descriptions below do not necessarily list every component of the required work unit. All work required by the Contract Documents that is related to a particular description is included in the unit price whether explicitly listed in the description below or not. The Schedule of Values and unit prices for individual items constituting the Contract Work, all as reflected in the Lump Sum bid amount noted above, shall include all contractor costs, overhead, profit, and coordination with the Owner and Architect/Engineer.

This is a Lump Sum Bid for all work described in the Contract Documents and the estimated quantities stated on the bid form. The purposed unit prices for materials or services will be used to adjust the contract sum by Change Order in the event the estimated quantities of Work are increased or decreased. The Lump Sum Bid may be increased (or decreased as applicable) for any or all Alternates prices listed below as approved by the Owner.

Schedule of Values: Base Bid

The following Schedule of Values must be included in the bid proposal. The contractor may provide a more elaborate Schedule of Values if they desire. The total of the Schedule of Values must equal the Lump Sum Base Bid listed above:

SECTION 00300 - BID FORM
 BASE BID UNIT PRICES AND BID AMOUNTS
 OXFORD TOWERS 50-YEAR ENV.REST REV1
 BID FORM REVISION 1

GENERAL CONDITIONS COST

	Item No.	Description	Bid Quantity [A1]	Unit	LUMP SUM WORK
General Conditions I	GC-1	Contractor shall mobilize and demobilize as necessary to perform the entire scope of work.	1	Lump Sum	\$ 98,000.00
	GC-2	Contractor shall be responsible for general conditions including protection of existing building and façade, protection of existing building finishes, weather protection, temporary support, project administration, debris containment, barriers, swing stage rentals, shoring, etc. General conditions are divided equally monthly.	1	Lump Sum	\$ 313,250.00
	GC-3	Contractor shall provide photographic documentation of existing conditions property and all areas that will be affected by construction work (including plaza deck, parking garage, staging areas etc.)	1	Lump Sum	Included
	GC-4	Contractor shall provide as-built drawings for unit price work performed on each payment application.	1	Lump Sum	Included
	GC-5	Temporary facilities	1	Lump Sum	Included
	GC-6	Protection of existing sliding glass doors, swing doors, and window frame systems with self-adhering protective film.	1	Lump Sum	Included
	GC-7	Contractor to provide shoring engineer drawings to support the structure during all demolition and put back activities in accord with the plans. Designated shoring locations as per engineer's drawings. Structural components requiring shoring such as slabs, walls, beams, etc. identified on engineer's drawings. Shoring post to have a minimum of 5 kip performance. All columns shall be braced prior to any demolition.	1	Lump Sum	Included
GC	Subtotal - General Conditions I				\$ 411,250.00
General Conditions II	GC-8	Obtain all permits necessary to permit the scope of work (excluding expediting)	1	AT COST	At Cost + \$800 Expediting Fee
	GC-9	Payment and Performance Bond/Labor and Material Bond	\$ 5,540,779.30	3.00%	\$ 166,223.38
	GC-10	Permit Expeditor	1	AT COST	At Cost + \$800 Expediting Fee
	GC	Subtotal - General Conditions II Passthrough Costs			

LUMP SUM WORK COST

	Item No.	Description	Reference	Bid Quantity [A1]	Unit	LUMP SUM WORK
STUCCO PAINT AND SEALANTS	PS-01	EXTERIOR STUCCO PAINT: Repaint the entire exterior of the building in accordance with the specifications. Paint to match existing color and texture. Work to include power wash the entire building, surface preparation on all stucco and concrete, surface conditioner, hot primer, primer, all in accordance with specifications and manufacturer recommendations, and a TWO-COAT paint system. Paint areas includes columns, walls, ceilings, balconies and all other elements at the exterior that are currently painted.	SPEC 99100	1	Lump Sum	\$ 344,804.00
	PS-02	BEAUTY BEAD SEALANTS: Total replacement of all secondary "beauty bead" sealant at ALL existing sliding glass doors, swing doors, window frame systems, louvers, and other penetrations.	SPEC 79200 SHEET S4-401	1	Lump Sum	\$ 107,096.00
	PS-03	INTERIOR STUCCO PAINT: Repaint the entire INTERIOR of the building east and west staircases in accordance with the specifications. Paint to match existing color and texture. Work to include power wash, surface preparation on all stucco and concrete, surface conditioner, hot primer, primer, all in accordance with specifications and manufacturer recommendations, and a ONE-COAT paint system. Paint areas includes columns, walls, ceilings, and all other elements at the staircases that are currently painted.	SPEC 99100	1	Lump Sum	\$ 33,610.00
	PS	Subtotal - Stucco Paint and Sealants				\$ 485,510.00
TOWER BALCONIES	TB-01	BALCONY TILE REMOVAL. Contractor shall remove and dispose of ALL tile and overburden from approx. four balconies. VIF. Consider 570 SF.	-	1	Lump Sum	\$ 5,449.00
	TB-02	BALCONY WATERPROOFING: Contractor shall remove exiting waterproofing membrane, grind down surface and prepare ALL horizontal balcony decks in accord with manufacture recommendation but no less than a CSP 3 to 5. Contractor shall install UV stable waterproofing assembly WITH A 20 YEAR MANUFACTURER WARRANTY in accord with TT's specifications and manufacturer recommendations. Approx. 12,200 SF VIF	SPEC 71800 SHEET S4-201, S1-202	1	Lump Sum	\$ 537,722.00
	TB-02 ALT	BALCONY WATERPROOFING: Contractor shall remove exiting waterproofing membrane, grind down surface and prepare ALL horizontal balcony decks in accord with manufacture recommendation but no less than a CSP 3 to 5. Contractor shall install UV stable waterproofing assembly WITH A 10 YEAR MANUFACTURER WARRANTY in accord with TT's specifications and manufacturer recommendations. Approx. 12,200 SF VIF	SPEC 71800 SHEET S4-201, S1-202	1	Lump Sum	\$ 288,838.00

Contractor is solely responsible for estimating quantities of all items listed as Lump Sum

Thornton Tomasetti

SECTION 00300 - BID FORM
 BASE BID UNIT PRICES AND BID AMOUNTS
 OXFORD TOWERS 50-YEAR ENV.REST REV1
 BID FORM REVISION 1

LUMP SUM WORK COST (CONT)

	Item No.	Description	Reference	Bid Quantity [A1]	Unit	LUMP SUM WORK
TOWER BALCONIES	TB-03	RAILING REPLACEMENT: Remove and replace existing aluminum railing AT ALL BALCONIES with new aluminum railing. Include railing at east/west entrances and pool entrances. Shop drawings by delegated engineer to be provided for review and approval, along with submittal to building department if necessary. Design to be in accordance with FBC Ch. 10 and FBC Ch. 16 requirements. Includes all slab reinforcement bars, sealants and fasteners required for installation of railings. Approx. 3,250 LF. For bidding purposes consider a 2-line, single opening peak-a-boo railing style	SPEC 57230 SHEET S4-201, S1-202	1	Lump Sum	\$ 778,176.00
	TB-04	SHUTTERS REMOVAL: Contractor shall remove all shutters from the entire building. Work to include removal of all embedded anchors. Consider 30% shutter removal for each type of exterior windows and doors.	SHEET S3-104	1	Lump Sum	\$ 53,647.50
	TB	Subtotal - Balcony Waterproofing Paint and Sealants				\$ 1,374,994.50
TOWER	TW-01	EAST STAIRS FOYER SLAB WATERPROOFING: Contractor shall remove exiting waterproofing membrane, grind down surface and prepare ALL slabs all ALL FLOORS in accord with manufacture recommendation but no less than a CSP 3 to 5. Contractor shall install UV stable traffic coating waterproofing assembly in accord with TT's specifications and manufacturer recommendations.	SPEC 71800 SHEET S1-202, S4-201	1	Lump Sum	\$ 8,975.00
	TW-02	WEST AND EAST STAIRS SLAB WATERPROOFING: Contractor shall remove exiting waterproofing membrane, grind down surface and prepare ALL slabs, stair steps and step risers all ALL FLOORS in accord with manufacture recommendation but no less than a CSP 3 to 5. Contractor shall install traffic coating waterproofing assembly in accord with TT's specifications and manufacturer recommendations.	SPEC 71800 SHEET S1-202, S4-201	1	Lump Sum	\$ 125,283.20
	TW-02 ALT	WEST AND EAST STAIRS SLAB WATERPROOFING Contractor shall remove exiting waterproofing membrane, grind down surface and prepare ALL slabs, stair steps and step risers all ALL FLOORS in accord with manufacture recommendation to receive a concrete stain sealer. 5. Contractor shall install traffic coating in accord with TT's specifications and manufacturer recommendations.	SHEET S1-202	1	Lump Sum	\$ 71,879.60
	TW-03A	EAST AND WEST STAIRS DOORS REPLACEMENT. Contractor to replace all East Staircase doors and frames at all floors. Foyer door and staircases door. Doors shall be fire rated with a glass panels. Include mechanical arm for all doors. Approx 46 doors. VIF	SHEET S1-202	1	Lump Sum	\$ 122,265.60
	TW-03B	ROOF ACCESS STAIRS DOORS REPLACEMENT. Contractor to replace stair doors accessing the roof, inclusive of new concrete curb and frame. Roof repairs by others. Doors shall be fire rated with a glass panels. Include mechanical arm for all doors. Approx 3 doors, VIF	SHEET S1-202	1	Lump Sum	\$ 7,965.00
	TW-04	EAST ENTRANCE DOOR REPLACEMENT. Contractor to replace EAST entry door and frame with an ADA compliant door. Include mechanical arm. VIF	SHEET S1-202	1	Lump Sum	\$ 5,595.00
	TW-05A	EAST ENTRANCE ROOF REPLACEMENT - Contractor shall remove exiting waterproofing membrane, grind down surface and prepare ALL SURFACES in accord with manufacture recommendation but no less than a CSP 3 to 5. Contractor shall install UV stable waterproofing assembly in WITH A 20 YEAR MANUFACTURER WARRANTY in accord with TT's specifications and manufacturer recommendations	SPEC 71800 SHEETS 3/S1-201 1-2/S4-201	1	Lump Sum	\$ 27,886.00
	TW-05A ALT	EAST ENTRANCE ROOF REPLACEMENT - Contractor shall remove exiting waterproofing membrane, grind down surface and prepare ALL SURFACES in accord with manufacture recommendation but no less than a CSP 3 to 5. Contractor shall install UV stable waterproofing assembly WITH A 10 YEAR MANUFACTURER WARRANTY in accord with TT's specifications and manufacturer recommendations	SPEC 71800 SHEETS 3/S1-201 1-2/S4-201	1	Lump Sum	\$ 15,300.00
	TW-05B	WEST ENTRANCE ROOF REPLACEMENT - Contractor shall remove exiting waterproofing membrane, grind down surface and prepare ALL SURFACES in accord with manufacture recommendation but no less than a CSP 3 to 5. Contractor shall install UV stable waterproofing assembly WITH A 20 YEAR MANUFACTURER WARRANTY in accord with TT's specifications and manufacturer recommendations	SPEC 71800 SHEET 4/S1-202 1-2/S4-201	1	Lump Sum	\$ 8,498.00
	TW-05B ALT	WEST ENTRANCE ROOF REPLACEMENT - Contractor shall remove exiting waterproofing membrane, grind down surface and prepare ALL SURFACES in accord with manufacture recommendation but no less than a CSP 3 to 5. Contractor shall install UV stable waterproofing assembly WITH A 10 YEAR MANUFACTURER WARRANTY in accord with TT's specifications and manufacturer recommendations	SPEC 71800 SHEET 4/S1-202 1-2/S4-201	1	Lump Sum	\$ 6,561.00
	TW-06	CABLE RUNWAYS REPLACEMENT - 6 stacks	S7-101 S7-102	1	ALLOWANCE	\$ 8,000.00
	TW-07	ROOF LEVEL 3 DOOR REPLACEMENT WITH NEW CONCRETE CURB, roof scope/ patching by others	SHEET S1-202	1	Lump Sum	Included in Line item TW-03B
	TW	Subtotal - Common Areas Lump Sum Work				\$ 314,467.80

Contractor is solely responsible for estimating quantities of all items listed as Lump Sum

Thornton Tomasetti

SECTION 00300 - BID FORM
 BASE BID UNIT PRICES AND BID AMOUNTS
 OXFORD TOWERS 50-YEAR ENV.REST REV1
 BID FORM REVISION 1

LUMP SUM WORK COST (CONT)

	Item No.	Description	Reference	Bid Quantity [A1]	Unit	LUMP SUM WORK	
CONCRETE AND STUCCO REPAIRS	CR-01	SLAB EDGE FULL DEPTH. Contractor shall remove and replace 12 inches width of all balconies slab edges in accord with ICRI guidelines, details and specifications. Assume slab thickness of 4.5 inches. This scope is in preparation for new aluminum railings per TB-03. Work to include new reinforcement bars, replacement of existing deteriorated steel, coating of new and existing exposed steel, surface prep, saw cutting and preformed drip edge, sealants, railing post pocket blockouts, and fasteners required for installation of railings. Approx. 3,250 LF VIF	SPEC 39300 SHEET 1/S3-102	1	Lump Sum	\$	629,303.00
	ST-01	WINDOWS SILL STUCCO REMOVAL - Remove and dispose of 12 inches stucco underneath of all windows extending 6 inches on each side. Install a reinforced cementitious membrane and install a with two-coat wall stucco in accordance with ASTM C926 and TT's details/specifications. Includes all stucco accessories. This is two coat stucco system. Area under windows approx. 1955 SF VIF	SPEC 92400 SHEET 2/S3-104	1	Lump Sum	\$	96,195.00
	TR	Subtotal - Tower Lump Sum Work					\$
Base Bid Lump Sum Total						\$	2,900,470.30

UNIT ITEMS WORK COST

	Item No.	Description	Reference	Bid Quantity [A1]	Unit	UNIT PRICE WORK	
						Unit Price [B1]	Bid Amount [A1 x B1]
HURRICANE, WEATHER WALLS AND MISC. PROTECTION	PR-01	WEATHER WALL - Contractor shall install a temporary wall for weather protection on the interior side of Sliding Glass Doors (Medium and Large Balconies). Wall shall be water tight and resist prescribing wind loads. Work to include shoring below. Consider a 100-inch wide Sliding Glass Door. Delegated Engineer Required	SHEET 1/S3-103	12	EA	\$ 1,314.00	\$ 15,768.00
	PR-02	WEATHER WALL - Contractor shall install a temporary wall for weather protection on the interior side of Swing Doors (Small Balconies). Wall shall be water tight and resist prescribing wind loads. Work to include shoring below. Consider a 24-inch wide swing door. Delegated Engineer Required.	SHEET 1/S3-103	12	EA	\$ 500.00	\$ 6,000.00
	PR-03	HURRICANE PROVISION Contractor shall demobilize, clean and secure the construction site prior to tropical storms and hurricanes. Contractor to remobilize site when reasonable and safe.	-	1	EA	\$ 1.00	\$ 1.00
	PS	Subtotal - Protection					\$
Concrete Repairs	CR-02	FULL DEPTH OF SLAB. Contractor shall remove and replace spalled concrete in accord with ICRI guidelines, details and specifications. Assume slab thickness of 6.5 inches. Work to include replacement of deteriorated steel, coating of exposed steel, surface prep and saw cutting.	SPEC 39300 SHEET 2/S3-102	1,750	SF	\$ 138.00	\$ 241,500.00
	CR-03	PARTIAL DEPTH OF SLAB. Contractor shall remove and replace spalled concrete up to 3 inches in depth in accord with ICRI guidelines, details and specifications. Work to include replacement of deteriorated steel, coating of exposed steel, surface prep and saw cutting.	SPEC 39300 SHEET 2/S3-102	2,200	SF	\$ 85.00	\$ 187,000.00
	CR-04	OVERHEAD PARTIAL DEPTH OF SLAB. Contractor shall remove and replace spalled concrete in accord with ICRI guidelines, details and specifications. Work to include replacement of deteriorated steel, coating of exposed steel, surface prep and saw cutting. Overhead repair areas shall not exceed 2.5 inches depth and One SF in area.	SPEC 39300 SHEET 2/S3-102	550	SF	\$ 125.00	\$ 68,750.00
	CR-05A	FULL BALCONY REPLACEMENT (UP TO 75 SF): Contractor shall remove and replace spalled concrete from FULL DEPTH OF SLAB in accord with ICRI guidelines, details and specifications. Assume slab thickness of 4.5 inches. Work to include replacement of deteriorated steel, coating of exposed steel, surface prep and saw cutting.	SPEC 32000, 33000, 39300 SHEETS 1-2/S1-201, 1/S3-103	12	EA	\$ 11,869.00	\$ 142,428.00
	CR-05B	FULL BALCONY REPLACEMENT (UP TO 110 SF): Contractor shall remove and replace spalled concrete from FULL DEPTH OF SLAB in accord with ICRI guidelines, details and specifications. Assume slab thickness of 4.5 inches. Work to include replacement of deteriorated steel, coating of exposed steel, surface prep and saw cutting.	SPEC 32000, 33000, 39300 SHEETS 5-6/S1-201, 1/S3-103	6	EA	\$ 17,737.00	\$ 106,422.00
	CR-05C	FULL BALCONY REPLACEMENT (UP TO 175 SF): Contractor shall remove and replace spalled concrete from FULL DEPTH OF SLAB in accord with ICRI guidelines, details and specifications. Assume slab thickness of 4.5 inches. Work to include replacement of deteriorated steel, coating of exposed steel, surface prep and saw cutting.	SPEC 32000, 33000, 39300 SHEETS 3-4/S1-201, 1/S3-103	6	EA	\$ 30,625.00	\$ 183,750.00
	CR-06	WINDOW OVERHEAD PARTIAL DEPTH REPAIR. Contractor shall remove windows to proceed with concrete work, remove and replace spalled concrete in accord with ICRI guidelines, details and specifications. Work to include replacement of deteriorated steel, coating of exposed steel, surface prep and saw cutting. Includes removal and reinstallation of window. Owner must provide window's information and NOA, and evidence of permitting records.	SPEC 39300 SHEET 3/S3-104	25	CF	\$ 550.00	\$ 13,750.00

Contractor is solely responsible for estimating quantities of all items listed as Lump Sum

Thornton Tomasetti

DATE: 4/27/2023

SECTION 00300 - BID FORM
 BASE BID UNIT PRICES AND BID AMOUNTS
 OXFORD TOWERS 50-YEAR ENV.REST REV1
 BID FORM REVISION 1

CR-07	CONCRETE COLUMNS: Contractor shall remove and replace spalled concrete in accord with ICRi guidelines, details and specifications. Work to include replacement of deteriorated steel, coating of exposed steel, surface prep and saw cutting.	SPEC 39300 SHEET 3/S3-102	250	CF	\$ 425.00	\$ 106,250.00
-------	---	---------------------------	-----	----	-----------	---------------

UNIT ITEMS WORK COST (CONT)

	Item No.	Description	Reference	Bid Quantity [A1]	Unit	UNIT PRICE WORK	
						Unit Price [B1]	Bid Amount [A1 x B1]
Concrete Repairs	CR-08A	STRUCTURAL CRACKS wider than 1/4". Epoxy inject cracks in structural concrete (with SIKADUR 31 HI-MOD GEL Cap Seal and SIKADUR 35, HI-MOD LV Epoxy Resin). Repairs per details and specifications.	SPEC 39300 SHEET S3-101	100	LF	\$ 75.00	\$ 7,500.00
	CR-08B	STRUCTURAL CRACKS wider than .004" and less than 1/4". Epoxy inject cracks in structural concrete (with SIKADUR 31 HI-MOD GEL Cap Seal and SIKADUR 35, HI-MOD LV Epoxy Resin). Repairs per details and specifications.	SPEC 39300 SHEET S3-101	100	LF	\$ 35.00	\$ 3,500.00
	CR-09	METAL INCLUSIONS :Misc. corroded foreign ferrous metal objects to be removed and replaced in accordance with ICRi guidelines, details and specifications. Shuttle's r anchors removal included on line item TB-04	SPEC 39250 SHEET 5/S3-101	1,000	EA	\$ 37.00	\$ 37,000.00
	CR-10A	WINDOW SILL REPLACEMENT (Type B/D) - Precast window sill 4"by 8" removal and replacement . Sill extends 4-inches past window opening on both sides. Consider a 50-inch wide window. Includes removal and reinstallation of window. Owner must provide window's information and NOA, and evidence of permitting records.	SHEET 1-2/S3-104	80	EA	\$ 1,011.00	\$ 80,880.00
	CR-10B	WINDOW SILL REPLACEMENT (Type A) - Precast window sill 4"by 8" removal and replacement . Sill extends 4-inches past window opening on both sides. Consider a 75 inch wide window. Includes removal and reinstallation of window. Owner must provide window's information and NOA, and evidence of permitting records.	SHEET 1-2/S3-104	10	EA	\$ 1,508.00	\$ 15,080.00
	CR-10C	WINDOW SILL REPLACEMENT (Type C) - Precast window sill 4"by 8" removal and replacement . Sill extends 4-inches past window opening on both sides. Consider a 25 inch wide window. Includes removal and reinstallation of window. Owner must provide window's information and NOA, and evidence of permitting records.	SHEET 1-2/S3-104	4	EA	\$ 695.00	\$ 2,780.00
	CR-11	CONCRETE TESTINGS: Provide third party concrete core testing for chlorides content and compression strenght	SPEC 014500	20	EA	\$ 1,500.00	\$ 30,000.00
	CR-12	BREEZE WALL REPLACEMENT: Replace deteriorated breeze wall, to match existing. Include cementitious waterproofing on entire opening, with 8 inches return to the inside and outside walls. Consider each opening of 28x90 inches, or 28 pieces per opening.	S7-102	5	EA	\$ 2,100.00	\$ 10,500.00
CR Subtotal - Concrete Repairs						\$	1,237,090.00
Stucco Repairs	ST-02	OVERHEAD SOFFIT STUCCO: Contractor shall remove and dispose of delaminated and/or damaged overhead soffit stucco. Contractor shall replace one-lift soffit stucco in accord with ASTM C926 and details/specifications. StoQuick Gold Soffit System preferred.	SPEC 92400 SHEET 7/S4-101	5,500	SF	\$ 49.00	\$ 269,500.00
	ST-03A	VERTICAL STUCCO: Contractor shall remove and dispose of delaminated and/or damaged vertical stucco on the tower envelope and balconies. Contractor shall replace two-lift wall stucco in accord with ASTM C926, details and specifications, including tuck-pointing.This is a two coat stucco.	SPEC 92400 SHEET 8/S4-101	10,800	SF	\$ 31.25	\$ 337,500.00
	ST-03B	VERTICAL STUCCO WITH BUILDOUT: Contractor shall remove and dispose of delaminated and/or damaged vertical wall stucco on the tower envelope and balconies. Contractor shall buildout and plumb misaligned substrate (assume 1" thickness) to insure stucco thickness does not exceed 5/8" section 039250. Contractor to replace two-lift wall stucco in accord with ASTM C926, details and specifications.	SPEC 39250 SPEC 92400 SHEET 9/S4-101	2,160	SF	\$ 45.00	\$ 97,200.00
	ST-04	SUBSTRATE JOINTS: Contractor shall install 8" wide plastic lath strips at all joints of dissimilar materials in accord with ASTM C926, details and specifications. Contractor to include tuck pointing and stainless steel fasteners	SPEC 92400 SHEET 4/S4-101	6,750	LF	\$ 16.00	\$ 108,000.00
	ST-05	PARAPET RIBBON WALL: Contractor to install Sto RFP mesh stucco system on parapet exterior wall ribbon and underside ceiling in accord with ASTM C926. Include Sto Prime. Include stucco.	SPEC 92400 SHEET 8/S4-101	3,500	SF	\$ 30.00	\$ 105,000.00
	ST Subtotal - Stucco Repairs						\$
Masonry Details	MR-01	MASONRY TUCK-POINTING REPAIRS: Repair deteriorated masonry components in accordance with TMS/ICRI guidelines, details and specifications. Work to include tuck-point between masonry runs, and at masonry/concrete transitions	SPEC 42200 SHEET 4/S3-301	1,500	LF	\$ 10.00	\$ 15,000.00
	MR-02	MASONRY FACE REPAIRS: Repair deteriorated masonry components in accordance with TMS/ICRI guidelines, details and specifications. Work to include gel patching of block face. Consider a blocks'cell width of 8 inches.	SPEC 42200 SHEET 4/S3-301	200	EA	\$ 40.00	\$ 8,000.00
	MR-03	MASONRY FILLED CELLS REPAIRS: Repair deteriorated masonry components in accordance with TMS/ICRI guidelines, details and specifications. Work to include replacement of deteriorated/missing steel, coating of exposed steel, surface prep, saw cutting, and grouting of empty cells. Consider a blocks'cell width of 8 inches.	SPEC 42200 SHEET 4/S3-301	200	EA	\$ 150.00	\$ 30,000.00
MR Subtotal - Masonry Repairs						\$	53,000.00

Contractor is solely responsible for estimating quantities of all items listed as Lump Sum

Thornton Tomasetti

DATE: 4/27/2023

SECTION 00300 - BID FORM
 BASE BID UNIT PRICES AND BID AMOUNTS
 OXFORD TOWERS 50-YEAR ENV.REST REV1
 BID FORM REVISION 1

Base Bid Unit Price Total	\$	2,229,059.00
----------------------------------	----	---------------------

BID COST SUMMARY

General Conditions I	\$	411,250.00
General Conditions II Passthrough Costs	\$	166,223.38
Base Bid Lump Sum Total	\$	2,900,470.30
Base Bid Unit Price Total	\$	2,229,059.00
Total Bid Price Estimate	\$	5,707,002.68

HURRICANES AND NAMED STORMS

	ITEM NO.	DESCRIPTION	Bid Quantity [A1]	PRICE	Unit
HURRICANES	H1	Hurricane Demobilization/Mobilization - Provide itemization of costs.	Each Occurrence	\$ 25,000.00	LS
	H2	Hurricane Demobilization - Provide estimated duration to demobilize the site in preparation for a hurricane.		TBD	DAYS
	H3	Hurricane ReMobilization - Provide estimated duration to remobilize the site.		TBD	DAYS

CONTRACT TIME DURATION	340	CALENDAR DAYS
Time/Material/Equipment Cost Plus	25	%

* NOTE: Any deviations from specified products must be specifically stated in the bid
 ** NOTE: Contractor to create mock-ups and receive written approval architect / engineer prior to the purchasing of materials for scope of work

Contractor is solely responsible for estimating quantities of all items listed as Lump Sum

Oxford Towers 50-Yr Recertification Repairs

March 23, 2023

CONTRACT TIME DURATION

Having taken fully into account all of the conditions set forth in the Agreement, Contractor agrees, without reservation to complete the Work, for all base bid and the estimated units described above, no later than 340 CALENDAR days after the receipt of Notice to Proceed for substantial completion.

SCHEDULE

1. The undersigned will submit in duplicate, at time of bid, a simplified Paragraph Schedule of the proposed Work under this Contract.
2. This proposal will remain in effect for a period of ninety (90) days from the time schedule for the submission of proposals.
3. The undersigned agrees to assume all increases in labor rates and/or material prices, which may develop during the life of this Contract.

BONDS

We have identified in the spaces below the cost of obtaining a Performance Bond and Labor and Material Payment Bond should it be made part of the Contract requirements.

Performance Bond

Labor and Material Bond

TOTAL

3 %

LABOR COST

Previously authorized LABOR COST work will be performed as provided in the General Conditions, except that the following rates shall apply.

1. Project Manager \$ 95.00 per hour
2. Project Supervision \$ 85.00 per hour
3. Skilled Carpenter \$ 85.00 per hour
4. Unskilled Labor \$ 65.00 per hour
5. Number of Crews on the Job \$ _____
7. Time /Material/Equipment Cost Plus 25 %

PROVIDE AS NEEDED ON A TIME AND MATERIAL BASIS:

Any electrical/plumbing repairs requested to be performed by the CONTRACTOR must be pre-approved by the OWNER or ENGINEER and shall be billed as additional fees.

Oxford Towers 50-Yr Recertification Repairs

March 23, 2023

ASSIGNMENT

The undersigned represent that no assignment, sublease or transfer of all or any part of his interest in the proposal has been made or will be made without the prior written consent of the Owner.

BIDDING DOCUMENTS

The undersigned acknowledges receipt of the Scope of Work and bidding documents and affirms that all costs associated therewith are included in the base bid single lump sum. The undersigned declares, by executing this proposal, that

1. All requirements concerning licensing and all other local, state and Federal Laws have been or will be complied with before commencement of the Work and that no legal requirements will be violated in the execution of the Work if the proposal is accepted.
2. No person or persons or company or other entity other than the firm listed below or otherwise indicated hereinafter in writing to the Owner and acceptable to the Owner has any interest whatsoever in the proposal or the Contract that may be entered into as a result thereof. This proposal is submitted in good faith without collusion or fraud.

The person or persons signing this proposal is/are fully authorized to sign on behalf of the named firm and to fully bind the named firm to all of the conditions and provisions thereof.

Oxford Towers 50-Yr Recertification Repairs

March 23, 2023

Submitted this 17th day of May, 2023.

Name of Firm Restore Construction Group, Inc

Street Address 2411 S.W. 58th Ter

City West Park State FL Zip Code 33023

Telephone 954-985-5353 Fax 954-985-5356

Operating as (complete and strike out words that do not apply)

A Corporation under the Laws of the State of Florida

A Partnership (give full name and address of all partners)

Juan Castro Jr. & Norge Arnaiz

2411 S.W. 58th Ter West Park, FL 33023

An Individual

BY: Name Alain Espinosa

Signature *Alain Espinosa*

Title Buisness Development

Witness: _____

Dated: May 17, 2023

SUPERINTENDENT

The bidder's superintendent to be onsite for the work specified shall be listed in the space provided below. The superintendent listed shall be onsite during all work activities. The superintendent shall not be changed without approval from the Owner.

Contractor's Superintendent T.B.D.



Ron DeSantis, Governor

Melanie S. Griffin, Secretary



**STATE OF FLORIDA
DEPARTMENT OF BUSINESS AND PROFESSIONAL REGULATION**

CONSTRUCTION INDUSTRY LICENSING BOARD

THE GENERAL CONTRACTOR HEREIN IS CERTIFIED UNDER THE
PROVISIONS OF CHAPTER 489, FLORIDA STATUTES

CASTRO, JUAN ANTONIO
RESTORE CONSTRUCTION GROUP, INC
2411 SW 58TH TERRACE
WEST PARK FL 33023

LICENSE NUMBER: CGC1515037

EXPIRATION DATE: AUGUST 31, 2024

Always verify licenses online at MyFloridaLicense.com

Do not alter this document in any form.

This is your license. It is unlawful for anyone other than the licensee to use this document.





CERTIFICATE OF LIABILITY INSURANCE

DATE (MM/DD/YYYY)

05/25/2023

THIS CERTIFICATE IS ISSUED AS A MATTER OF INFORMATION ONLY AND CONFERS NO RIGHTS UPON THE CERTIFICATE HOLDER. THIS CERTIFICATE DOES NOT AFFIRMATIVELY OR NEGATIVELY AMEND, EXTEND OR ALTER THE COVERAGE AFFORDED BY THE POLICIES BELOW. THIS CERTIFICATE OF INSURANCE DOES NOT CONSTITUTE A CONTRACT BETWEEN THE ISSUING INSURER(S), AUTHORIZED REPRESENTATIVE OR PRODUCER, AND THE CERTIFICATE HOLDER.

IMPORTANT: If the certificate holder is an ADDITIONAL INSURED, the policy(ies) must have ADDITIONAL INSURED provisions or be endorsed. If SUBROGATION IS WAIVED, subject to the terms and conditions of the policy, certain policies may require an endorsement. A statement on this certificate does not confer rights to the certificate holder in lieu of such endorsement(s).

PRODUCER Brown & Brown of Florida, Inc. 8825 NW 21st Terrace Doral FL 33172		CONTACT NAME: Yamile Corral AAI, AAIM PHONE (A/C, No, Ext): (305) 714-4400 FAX (A/C, No): (305) 714-4401 E-MAIL ADDRESS: Yamile.Corral@bbrown.com	
INSURED Restore Construction Group Inc 2411 SW 58th Terrace West Park FL 33023		INSURER(S) AFFORDING COVERAGE INSURER A: Navigators Specialty Insurance Company INSURER B: Hartford Accident and Indemnity Company INSURER C: Endurance American Specialty Insurance Company INSURER D: Bridgefield Casualty Insurance Company INSURER E: Federal Insurance Company INSURER F:	
		NAIC # 22357 20281	

COVERAGES **CERTIFICATE NUMBER:** 2023 Master Cert **REVISION NUMBER:**

THIS IS TO CERTIFY THAT THE POLICIES OF INSURANCE LISTED BELOW HAVE BEEN ISSUED TO THE INSURED NAMED ABOVE FOR THE POLICY PERIOD INDICATED. NOTWITHSTANDING ANY REQUIREMENT, TERM OR CONDITION OF ANY CONTRACT OR OTHER DOCUMENT WITH RESPECT TO WHICH THIS CERTIFICATE MAY BE ISSUED OR MAY PERTAIN, THE INSURANCE AFFORDED BY THE POLICIES DESCRIBED HEREIN IS SUBJECT TO ALL THE TERMS, EXCLUSIONS AND CONDITIONS OF SUCH POLICIES. LIMITS SHOWN MAY HAVE BEEN REDUCED BY PAID CLAIMS.

INSR LTR	TYPE OF INSURANCE	ADDL	SUBR	POLICY NUMBER	POLICY EFF (MM/DD/YYYY)	POLICY EXP (MM/DD/YYYY)	LIMITS
A	<input checked="" type="checkbox"/> COMMERCIAL GENERAL LIABILITY <input type="checkbox"/> CLAIMS-MADE <input checked="" type="checkbox"/> OCCUR <input checked="" type="checkbox"/> Contractual Limit <input checked="" type="checkbox"/> XCU GEN'L AGGREGATE LIMIT APPLIES PER: <input type="checkbox"/> POLICY <input checked="" type="checkbox"/> PROJECT <input type="checkbox"/> LOC OTHER:	Y	Y	GA23CGL0DNQ21C	05/31/2023	05/31/2024	EACH OCCURRENCE \$ 1,000,000 DAMAGE TO RENTED PREMISES (Ea occurrence) \$ 50,000 MED EXP (Any one person) \$ 10,000 PERSONAL & ADV INJURY \$ 1,000,000 GENERAL AGGREGATE \$ 2,000,000 PRODUCTS - COMP/OP AGG \$ 2,000,000
B	<input checked="" type="checkbox"/> AUTOMOBILE LIABILITY <input checked="" type="checkbox"/> ANY AUTO <input type="checkbox"/> OWNED AUTOS ONLY <input type="checkbox"/> SCHEDULED AUTOS <input type="checkbox"/> HIRED AUTOS ONLY <input type="checkbox"/> NON-OWNED AUTOS ONLY			21UECHZ3168	05/31/2023	05/31/2024	COMBINED SINGLE LIMIT (Ea accident) \$ 1,000,000 BODILY INJURY (Per person) \$ BODILY INJURY (Per accident) \$ PROPERTY DAMAGE (Per accident) \$ Underinsured motorist \$ 1,000,000
C	<input type="checkbox"/> UMBRELLA LIAB <input checked="" type="checkbox"/> OCCUR <input checked="" type="checkbox"/> EXCESS LIAB <input type="checkbox"/> CLAIMS-MADE <input type="checkbox"/> DED <input checked="" type="checkbox"/> RETENTION \$ 0			ELD30019882301	05/31/2023	05/31/2024	EACH OCCURRENCE \$ 5,000,000 AGGREGATE \$ 5,000,000
D	WORKERS COMPENSATION AND EMPLOYERS' LIABILITY ANY PROPRIETOR/PARTNER/EXECUTIVE OFFICER/MEMBER EXCLUDED? (Mandatory in NH) If yes, describe under DESCRIPTION OF OPERATIONS below	Y/N	N/A	19642473	05/31/2023	05/31/2024	<input checked="" type="checkbox"/> PER STATUTE <input type="checkbox"/> OTHER E.L. EACH ACCIDENT \$ 1,000,000 E.L. DISEASE - EA EMPLOYEE \$ 1,000,000 E.L. DISEASE - POLICY LIMIT \$ 1,000,000
E	Inland Marine			45474511	05/31/2023	05/31/2024	Leased or Rented Eqp \$100,000

DESCRIPTION OF OPERATIONS / LOCATIONS / VEHICLES (ACORD 101, Additional Remarks Schedule, may be attached if more space is required)

RE: Palm Bay Towers Condominium Association, Inc.
 KW Property Management and Consulting, LLC
 720 NE 69 St
 Miami, FL 33138

Restore Construction Group, Inc and Palm Bay Towers Condominium Association Inc., and KW Property Management & Consulting LLC are additional insured with regards to General Liability coverage when required by written contract. Waiver of Subrogation applies with regards to General Liability and

CERTIFICATE HOLDER**CANCELLATION**

Restore Construction Group, Inc. 2411 SW 58th Terrace West Park FL 33023	SHOULD ANY OF THE ABOVE DESCRIBED POLICIES BE CANCELLED BEFORE THE EXPIRATION DATE THEREOF, NOTICE WILL BE DELIVERED IN ACCORDANCE WITH THE POLICY PROVISIONS. AUTHORIZED REPRESENTATIVE 
--	---

© 1988-2015 ACORD CORPORATION. All rights reserved.



VALCOURT

WATERPROOFING
& RESTORATION

Valcourt Exterior Building Services of Florida, L.C. | 941-747-7277

4695 18th Street East, Bradenton, FL 34203

May 12th, 2023

Re: Oxford Towers Condominium-Envelope Restoration

Please find enclosed the completed bid form and supplementary information for the Oxford Towers Condominium project.

In addition to the completed bid form we have included a list of Bid Qualifications/Clarifications which help explain our Bid for this project.

Should you have any questions or require additional information, please feel free to call me at 863-244-3495.

Sincerely,

Antonio Posadas
Business Development Manager
APosadas@Valcourt.net
850-499-4066

Oxford Towers Condominium – Exterior Restoration

May 12th, 2023

VALCOURT EXTERIOR BUILDING SERVICES OF FLORIDA, L.C. (Valcourt)

PROPOSAL/BID RESERVATIONS

Valcourt very much appreciates the opportunity to present the attached Proposal/Bid in response to the Owner's request.

The Owner's or Consultant's acceptance of Valcourt's Proposal/Bid signifies and ratifies that, notwithstanding any contrary or conflicting provision in the "Bid Documents" (including Project Manual, Specifications, Conditions, Bid Form, Request for Proposal or any other document), Valcourt submits the attached Proposal/Bid contingent upon Valcourt's right to negotiate the proposed Contract language prior to its execution, and the understanding that Valcourt's Proposal/Bid is merely the expression of an intention to enter into a binding Contract with the Owner, after our good faith negotiation.

Additionally, the "Proposal Price/Bid Price" (including all Alternate, Unit, and Time & Material pricing) for this Project has been calculated based on the current cost of component building materials. The market for building materials is currently experiencing unprecedented volatility, and the prices of materials are increasing at an uncontrolled rate and pace. Considering this, and notwithstanding any contrary or conflicting provision in the "Bid Documents", if there is an increase in the price of any applicable materials subsequent to the date of this Proposal/Bid, the Proposal Price/Bid Price, and the resulting Contract Sum/Price, will increase accordingly. Notwithstanding, any contrary or conflicting provision in the "Bid Documents", Valcourt submits the attached Proposal/Bid contingent upon Valcourt's right to increase the Proposal Price/Bid Price, and the resulting Contract Sum/Price, by the amount of any increased costs of materials prior to, or during, the performance of the Work by Valcourt.

Sincerely,

Valcourt Exterior Building Services of Florida, L.C.

BID QUALIFICATIONS/CLARIFICATIONS

- Bid Item TB-03- Railing Replacement: Pricing includes post pockets as per detail #S4-301.
- Bid Item TW-04- East Entrance Door Replacement: Pricing is for ESW, NOW #19-0708.4.
- Bid Item TW-01- East Stairs Foyer Slab Waterproofing: Pricing is based upon an allowance of 15 Square Feet.
- **ADD ALTERNATE: Valcourt proposes an alternate for Balcony Waterproofing utilizing Sika Sikalastic RoofPro system. ADD \$322,590.00.**
- Repairs of Window interiors are not included.
- Stucco Repairs are limited to up to 5/8" thickness.
- Valcourt respectfully must decline to bid the Electrical Work (Addendum 1) at this time. This work would be performed by a Subcontractor and quotes have not been forthcoming at the time of bid submission.
- Unit Price Work: Repairs will be quantified at a minimum of one (1) unit per location.
- If not already installed, and where required, Valcourt will supply pigtailed for each swing stage anticipated for use on the project, for Owner's Electrician to install.



Oxford Towers Condominium – Exterior Restoration

- Performance and Payment Bonds are included in the bid pricing. Should the owner elect to obtain P & P Bonds for this project, they will be provided at a cost of 2% of the total contract including any accepted alternates/options. **Bonds are for the duration of the project only. If any additional maintenance bonds are required, additional charges may apply.**
- Permitting fees are not included. If required, permit costs shall be by Change Order and shall be billed as direct cost to Owner, including permit administrative or expediter fees (if applicable).

BID PROPOSAL FORM

Name of Bidder Valcourt Exterior Building Services of Florida, L.C.

Address 4695 18th Street East, Bradenton, FL 34203

Telephone Number 941-747-7277

PROPOSAL FOR THE

The Oxford Towers Condominium Porte Cochere Replacement

OWNER

Oxford Towers Condominium Association, Inc

1501 South Ocean Drive, Hollywood, FL 33019

Contact: PROPERTY MANAGER

ENGINEER

Thornton Tomasetti

101 NE Third Avenue, Suite 1170

Fort Lauderdale, FL 33301

tel: 954.903.9300

Contact: Hector Guerra P.E. AND Vanessa Da Rocha, AIA

To Whom It May Concern:

The undersigned, having fully examined the Scope of Work and having examined the premises and familiarized themselves with conditions likely to be encountered affecting the cost and schedule, makes the following proposal to provide all labor, materials, equipment and services required to perform and complete the Work in accordance with the Scope of Work document.

BASE BID

We agree to perform and complete all Work described in the Drawings and Project Specifications and any Addenda which may be issued thereto during the bidding period; and, if this proposal is accepted, will execute a formal contract in the form that is bound into the Project Manual, to this effect, for the LUMP SUM price of

1Five Million, Five Hundred Seventy-Six DOLLARS (\$ 5,576,637.84)
Thousand, Six Hundred Thirty-Seven Dollars and Eighty-Four Cents.

It is understood that the work descriptions below do not necessarily list every component of the required work unit. All work required by the Contract Documents that is related to a particular description is included in the unit price whether explicitly listed in the description below or not. The Schedule of Values and unit prices for individual items constituting the Contract Work, all as reflected in the Lump Sum bid amount noted above, shall include all contractor costs, overhead, profit, and coordination with the Owner and Architect/Engineer.

This is a Lump Sum Bid for all work described in the Contract Documents and the estimated quantities stated on the bid form. The purposed unit prices for materials or services will be used to adjust the contract sum by Change Order in the event the estimated quantities of Work are increased or decreased. The Lump Sum Bid may be increased (or decreased as applicable) for any or all Alternates prices listed below as approved by the Owner.

Schedule of Values: Base Bid

The following Schedule of Values must be included in the bid proposal. The contractor may provide a more elaborate Schedule of Values if they desire. The total of the Schedule of Values must equal the Lump Sum Base Bid listed above:

SECTION 00300 - BID FORM
 BASE BID UNIT PRICES AND BID AMOUNTS
 OXFORD TOWERS 50-YEAR ENV.REST REV1
 BID FORM REVISION 1

GENERAL CONDITIONS COST

	Item No.	Description	Bid Quantity [A1]	Unit	LUMP SUM WORK
General Conditions I	GC-1	Contractor shall mobilize and demobilize as necessary to perform the entire scope of work.	1	Lump Sum	\$ 64,200.00
	GC-2	Contractor shall be responsible for general conditions including protection of existing building and façade, protection of existing building finishes, weather protection, temporary support, project administration, debris containment, barriers, swing stage rentals, shoring, etc. General conditions are divided equally monthly.	1	Lump Sum	\$ 663,860.00
	GC-3	Contractor shall provide photographic documentation of existing conditions property and all areas that will be affected by construction work (including plaza deck, parking garage, staging areas etc.)	1	Lump Sum	\$ 1,800.00
	GC-4	Contractor shall provide as-built drawings for unit price work performed on each payment application.	1	Lump Sum	\$ 6,750.00
	GC-5	Temporary facilities	1	Lump Sum	\$ 67,805.00
	GC-6	Protection of existing sliding glass doors, swing doors, and window frame systems with self-adhering protective film.	1	Lump Sum	\$ 44,850.00
	GC-7	Contractor to provide shoring engineer drawings to support the structure during all demolition and put back activities in accord with the plans. Designated shoring locations as per engineer's drawings. Structural components requiring shoring such as slabs, walls, beams, etc. identified on engineer's drawings. Shoring post to have a minimum of 5 kip performance. All columns shall be braced prior to any demolition.	1	Lump Sum	\$ 17,700.00
	GC	Subtotal - General Conditions I			\$ 866,965.00
General Conditions II	GC-8	Obtain all permits necessary to permit the scope of work (excluding expediting)	1	AT COST	TBD
	GC-9	Payment and Performance Bond/Labor and Material Bond		%	\$ 109,345.84
	GC-10	Permit Expeditor	1	AT COST	TBD
	GC	Subtotal - General Conditions II Passthrough Costs			\$ 109,345.84

LUMP SUM WORK COST

	Item No.	Description	Reference	Bid Quantity [A1]	Unit	LUMP SUM WORK
STUCCO PAINT AND SEALANTS	PS-01	EXTERIOR STUCCO PAINT: Repaint the entire exterior of the building in accordance with the specifications. Paint to match existing color and texture. Work to include power wash the entire building, surface preparation on all stucco and concrete, surface conditioner, hot primer, primer, all in accordance with specifications and manufacturer recommendations, and a TWO-COAT paint system. Paint areas includes columns, walls, ceilings, balconies and all other elements at the exterior that are currently painted.	SPEC 99100	1	Lump Sum	\$ 206,450.00
	PS-02	BEAUTY BEAD SEALANTS: Total replacement of all secondary "beauty bead" sealant at ALL existing sliding glass doors, swing doors, window frame systems, louvers, and other penetrations.	SPEC 79200 SHEET S4-401	1	Lump Sum	\$ 80,360.00
	PS-03	INTERIOR STUCCO PAINT: Repaint the entire INTERIOR of the building east and west staircases in accordance with the specifications. Paint to match existing color and texture. Work to include power wash, surface preparation on all stucco and concrete, surface conditioner, hot primer, primer, all in accordance with specifications and manufacturer recommendations, and a ONE-COAT paint system. Paint areas includes columns, walls, ceilings, and all other elements at the staircases that are currently painted.	SPEC 99100	1	Lump Sum	\$ 28,350.00
	PS	Subtotal - Stucco Paint and Sealants				\$ 315,160.00
TOWER BALCONIES	TB-01	BALCONY TILE REMOVAL. Contractor shall remove and dispose of ALL tile and overburden from approx. four balconies. VIF. Consider 570 SF.	-	1	Lump Sum	\$ 3,780.00
	TB-02	BALCONY WATERPROOFING: Contractor shall remove exiting waterproofing membrane, grind down surface and prepare ALL horizontal balcony decks in accord with manufacture recommendation but no less than a CSP 3 to 5. Contractor shall install UV stable waterproofing assembly WITH A 20 YEAR MANUFACTURER WARRANTY in accord with TT's specifications and manufacturer recommendations. Approx. 12,200 SF VIF	SPEC 71800 SHEET S4-201, S1-202	1	Lump Sum	\$ 313,025.00
	TB-02 ALT	BALCONY WATERPROOFING: Contractor shall remove exiting waterproofing membrane, grind down surface and prepare ALL horizontal balcony decks in accord with manufacture recommendation but no less than a CSP 3 to 5. Contractor shall install UV stable waterproofing assembly WITH A 10 YEAR MANUFACTURER WARRANTY in accord with TT's specifications and manufacturer recommendations. Approx. 12,200 SF VIF	SPEC 71800 SHEET S4-201, S1-202	1	Lump Sum	\$ 123,920.00

Contractor is solely responsible for estimating quantities of all items listed as Lump Sum

SECTION 00300 - BID FORM
 BASE BID UNIT PRICES AND BID AMOUNTS
 OXFORD TOWERS 50-YEAR ENV.REST REV1
 BID FORM REVISION 1

LUMP SUM WORK COST (CONT)

	Item No.	Description	Reference	Bid Quantity [A1]	Unit	LUMP SUM WORK
TOWER BALCONIES	TB-03	RAILING REPLACEMENT: Remove and replace existing aluminum railing AT ALL BALCONIES with new aluminum railing. Include railing at east/west entrances and pool entrances. Shop drawings by delegated engineer to be provided for review and approval, along with submittal to building department if necessary. Design to be in accordance with FBC Ch. 10 and FBC Ch. 16 requirements. Includes all slab reinforcement bars, sealants and fasteners required for installation of railings. Approx. 3,250 LF. For bidding purposes consider a 2-line, single opening peak-a-boo railing style	SPEC 57230 SHEET S4-201, S1-202	1	Lump Sum	\$ 822,480.00
	TB-04	SHUTTERS REMOVAL: Contractor shall remove all shutters from the entire building. Work to include removal of all embedded anchors. Consider 30% shutter removal for each type of exterior windows and doors.	SHEET S3-104	1	Lump Sum	\$ 25,660.00
	TB	Subtotal - Balcony Waterproofing Paint and Sealants				\$ 1,164,945.00
TOWER	TW-01	EAST STAIRS FOYER SLAB WATERPROOFING: Contractor shall remove existing waterproofing membrane, grind down surface and prepare ALL slabs all ALL FLOORS in accord with manufacture recommendation but no less than a CSP 3 to 5. Contractor shall install UV stable traffic coating waterproofing assembly in accord with TT's specifications and manufacturer recommendations.	SPEC 71800 SHEET S1-202, S4-201	1	Lump Sum	\$ 500.00
	TW-02	WEST AND EAST STAIRS SLAB WATERPROOFING: Contractor shall remove existing waterproofing membrane, grind down surface and prepare ALL slabs, stair steps and step risers all ALL FLOORS in accord with manufacture recommendation but no less than a CSP 3 to 5. Contractor shall install traffic coating waterproofing assembly in accord with TT's specifications and manufacturer recommendations.	SPEC 71800 SHEET S1-202, S4-201	1	Lump Sum	\$ 48,300.00
	TW-02 ALT	WEST AND EAST STAIRS SLAB WATERPROOFING Contractor shall remove existing waterproofing membrane, grind down surface and prepare ALL slabs, stair steps and step risers all ALL FLOORS in accord with manufacture recommendation to receive a concrete stain sealer. 5. Contractor shall install traffic coating in accord with TT's specifications and manufacturer recommendations.	SHEET S1-202	1	Lump Sum	\$ 37,320.00
	TW-03A	EAST AND WEST STAIRS DOORS REPLACEMENT. Contractor to replace all East Staircase doors and frames at all floors, <u>Foyer door and staircases door</u> . Doors shall be fire rated with a glass panels. Include mechanical arm for all doors. Approx 46 doors. VIF	SHEET S1-202	1	Lump Sum	\$ 195,060.00
	TW-03B	ROOF ACCESS STAIRS DOORS REPLACEMENT. Contractor to replace stair doors accessing the roof, inclusive of new concrete curb and frame. Roof repairs by others. Doors shall be fire rated with a glass panels. Include mechanical arm for all doors. Approx 3 doors, VIF	SHEET S1-202	1	Lump Sum	\$ 12,721.00
	TW-04	EAST ENTRANCE DOOR REPLACEMENT. Contractor to replace EAST entry door and frame with an ADA compliant door. Include mechanical arm. VIF	SHEET S1-202	1	Lump Sum	\$ 13,944.00
	TW-05A	EAST ENTRANCE ROOF REPLACEMENT - Contractor shall remove existing waterproofing membrane, grind down surface and prepare ALL SURFACES in accord with manufacture recommendation but no less than a CSP 3 to 5. Contractor shall install UV stable waterproofing assembly in WITH A 20 YEAR MANUFACTURER WARRANTY in accord with TT's specifications and manufacturer recommendations	SPEC 71800 SHEETS 3/S1-201 1-2/S4-201	1	Lump Sum	\$ 15,200.00
	TW-05A ALT	EAST ENTRANCE ROOF REPLACEMENT - Contractor shall remove existing waterproofing membrane, grind down surface and prepare ALL SURFACES in accord with manufacture recommendation but no less than a CSP 3 to 5. Contractor shall install UV stable waterproofing assembly WITH A 10 YEAR MANUFACTURER WARRANTY in accord with TT's specifications and manufacturer recommendations	SPEC 71800 SHEETS 3/S1-201 1-2/S4-201	1	Lump Sum	\$ 6,600.00
	TW-05B	WEST ENTRANCE ROOF REPLACEMENT - Contractor shall remove existing waterproofing membrane, grind down surface and prepare ALL SURFACES in accord with manufacture recommendation but no less than a CSP 3 to 5. Contractor shall install UV stable waterproofing assembly WITH A 20 YEAR MANUFACTURER WARRANTY in accord with TT's specifications and manufacturer recommendations	SPEC 71800 SHEET 4/S1-202 1-2/S4-201	1	Lump Sum	\$ 5,300.00
	TW-05B ALT	WEST ENTRANCE ROOF REPLACEMENT - Contractor shall remove existing waterproofing membrane, grind down surface and prepare ALL SURFACES in accord with manufacture recommendation but no less than a CSP 3 to 5. Contractor shall install UV stable waterproofing assembly WITH A 10 YEAR MANUFACTURER WARRANTY in accord with TT's specifications and manufacturer recommendations	SPEC 71800 SHEET 4/S1-202 1-2/S4-201	1	Lump Sum	\$ 2,610.00
	TW-06	CABLE RUNWAYS REPLACEMENT - 6 stacks	S7-101 S7-102	1	ALLOWANCE	\$ 10,000.00
	TW-07	ROOF LEVEL 3 DOOR REPLACEMENT WITH NEW CONCRETE CURB, roof scope/ patching by others	SHEET S1-202	1	Lump Sum	\$ 13,361.00
	TW	Subtotal - Common Areas Lump Sum Work				\$ 314,386.00

Contractor is solely responsible for estimating quantities of all items listed as Lump Sum

SECTION 00300 - BID FORM
 BASE BID UNIT PRICES AND BID AMOUNTS
 OXFORD TOWERS 50-YEAR ENV.REST REV1
 BID FORM REVISION 1

LUMP SUM WORK COST (CONT)

	Item No.	Description	Reference	Bid Quantity [A1]	Unit	LUMP SUM WORK	
CONCRETE AND STUCCO REPAIRS	CR-01	SLAB EDGE FULL DEPTH. Contractor shall remove and replace 12 inches width of all balconies slab edges in accord with ICRi guidelines, details and specifications. Assume slab thickness of 4.5 inches. This scope is in preparation for new aluminum railings per TB-03. Work to include new reinforcement bars, replacement of existing deteriorated steel, coating of new and existing exposed steel, surface prep, saw cutting and preformed drip edge, sealants, railing post pocket blockouts, and fasteners required for installation of railings. Approx. 3,250 LF VIF	SPEC 39300 SHEET 1/S3-102	1	Lump Sum	\$	691,500.00
	ST-01	WINDOWS SILL STUCCO REMOVAL - Remove and dispose of 12 inches stucco underneath of all windows extending 6 inches on each side. Install a reinforced cementitious membrane and install a with two-coat wall stucco in accordance with ASTM C926 and TT's details/specifications. Includes all stucco accessories. This is two coat stucco system. Area under windows approx. 1955 SF VIF	SPEC 92400 SHEET 2/S3-104	1	Lump Sum	\$	71,200.00
	TR	Subtotal - Tower Lump Sum Work					\$
Base Bid Lump Sum Total						\$	2,557,191.00

UNIT ITEMS WORK COST

	Item No.	Description	Reference	Bid Quantity [A1]	Unit	UNIT PRICE WORK	
						Unit Price [B1]	Bid Amount [A1 x B1]
HURRICANE, WEATHER WALLS AND MISC. PROTECTION	PR-01	WEATHER WALL - Contractor shall install a temporary wall for weather protection on the interior side of Sliding Glass Doors (Medium and Large Balconies). Wall shall be water tight and resist prescribng wind loads. Work to include shoring below. Consider a 100-inch wide Sliding Glass Door. Delegated Engineer Required	SHEET 1/S3-103	12	EA	\$ 763.00	\$ 9,156.00
	PR-02	WEATHER WALL - Contractor shall install a temporary wall for weather protection on the interior side of Swing Doors (Small Balconies). Wall shall be water tight and resist prescribng wind loads. Work to include shoring below. Consider a 24-inch wide swing door. Delegated Engineer Required.	SHEET 1/S3-103	12	EA	\$ 297.00	\$ 3,564.00
	PR-03	HURRICANE PROVISION Contractor shall demolize, clean and secure the construction site prior to tropical storms and hurricanes. Contractor to remobilize site when reasonable and safe.	-	1	EA	\$ 78,500.00	\$ 78,500.00
	PS	Subtotal - Protection					\$
Concrete Repairs	CR-02	FULL DEPTH OF SLAB. Contractor shall remove and replace spalled concrete in accord with ICRi guidelines, details and specifications. Assume slab thickness of 6.5 inches. Work to include replacement of deteriorated steel, coating of exposed steel, surface prep and saw cutting.	SPEC 39300 SHEET 2/S3-102	1,750	SF	\$ 170.50	\$ 298,375.00
	CR-03	PARTIAL DEPTH OF SLAB. Contractor shall remove and replace spalled concrete up to 3 inches in depth in accord with ICRi guidelines, details and specifications. Work to include replacement of deteriorated steel, coating of exposed steel, surface prep and saw cutting.	SPEC 39300 SHEET 2/S3-102	2,200	SF	\$ 68.00	\$ 149,600.00
	CR-04	OVERHEAD PARTIAL DEPTH OF SLAB. Contractor shall remove and replace spalled concrete in accord with ICRi guidelines, details and specifications. Work to include replacement of deteriorated steel, coating of exposed steel, surface prep and saw cutting. Overhead repair areas shall not exceed 2.5 inches depth and One SF in area.	SPEC 39300 SHEET 2/S3-102	550	SF	\$ 107.00	\$ 58,850.00
	CR-05A	FULL BALCONY REPLACEMENT (UP TO 75 SF): Contractor shall remove and replace spalled concrete from FULL DEPTH OF SLAB in accord with ICRi guidelines, details and specifications. Assume slab thickness of 4.5 inches. Work to include replacement of deteriorated steel, coating of exposed steel, surface prep and saw cutting.	SPEC 32000, 33000, 39300 SHEETS 1-2/S1-201, 1/S3-103	12	EA	\$ 10,865.83	\$ 130,390.00
	CR-05B	FULL BALCONY REPLACEMENT (UP TO 110 SF): Contractor shall remove and replace spalled concrete from FULL DEPTH OF SLAB in accord with ICRi guidelines, details and specifications. Assume slab thickness of 4.5 inches. Work to include replacement of deteriorated steel, coating of exposed steel, surface prep and saw cutting.	SPEC 32000, 33000, 39300 SHEETS 5-6/S1-201, 1/S3-103	6	EA	\$ 15,936.67	\$ 95,620.00
	CR-05C	FULL BALCONY REPLACEMENT (UP TO 175 SF): Contractor shall remove and replace spalled concrete from FULL DEPTH OF SLAB in accord with ICRi guidelines, details and specifications. Assume slab thickness of 4.5 inches. Work to include replacement of deteriorated steel, coating of exposed steel, surface prep and saw cutting.	SPEC 32000, 33000, 39300 SHEETS 3-4/S1-201, 1/S3-103	6	EA	\$ 25,354.17	\$ 152,125.00
	CR-06	WINDOW OVERHEAD PARTIAL DEPTH REPAIR. Contractor shall remove windows to proceed with concrete work, remove and replace spalled concrete in accord with ICRi guidelines, details and specifications. Work to include replacement of deteriorated steel, coating of exposed steel, surface prep and saw cutting. Includes removal and reinstallation of window. Owner must provide window's information and NOA, and evidence of permitting records.	SPEC 39300 SHEET 3/S3-104	25	CF	\$ 1,178.00	\$ 29,450.00
CR-07	CONCRETE COLUMNS: Contractor shall remove and replace spalled concrete in accord with ICRi guidelines, details and specifications. Work to include replacement of deteriorated steel, coating of exposed steel, surface prep and saw cutting.	SPEC 39300 SHEET 3/S3-102	250	CF	\$ 441.50	\$ 110,375.00	

Contractor is solely responsible for estimating quantities of all items listed as Lump Sum

SECTION 00300 - BID FORM
 BASE BID UNIT PRICES AND BID AMOUNTS
 OXFORD TOWERS 50-YEAR ENV.REST REV1
 BID FORM REVISION 1

UNIT ITEMS WORK COST (CONT)

	Item No.	Description	Reference	Bid Quantity [A1]	Unit	UNIT PRICE WORK		
						Unit Price [B1]	Bid Amount [A1 x B1]	
Concrete Repairs	CR-08A	STRUCTURAL CRACKS wider than 1/4". Epoxy inject cracks in structural concrete (with SIKADUR 31 HI-MOD GEL Cap Seal and SIKADUR 35, HI-MOD LV Epoxy Resin). Repairs per details and specifications.	SPEC 39300 SHEET S3-101	100	LF	\$ 91.00	\$ 9,100.00	
	CR-08B	STRUCTURAL CRACKS wider than .004" and less than 1/4". Epoxy inject cracks in structural concrete (with SIKADUR 31 HI-MOD GEL Cap Seal and SIKADUR 35, HI-MOD LV Epoxy Resin). Repairs per details and specifications.	SPEC 39300 SHEET S3-101	100	LF	\$ 82.00	\$ 8,200.00	
	CR-09	METAL INCLUSIONS :Misc. corroded foreign ferrous metal objects to be removed and replaced in accordance with ICRI guidelines, details and specifications. Shutte's r anchors removal included on line item TB-04	SPEC 39250 SHEET 5/S3-101	1,000	EA	\$ 15.50	\$ 15,500.00	
	CR-10A	WINDOW SILL REPLACEMENT (Type B/D) - Precast window sill 4"by 8" removal and replacement . Sill extends 4-inches past window opening on both sides. Consider a 50-inch wide window. Includes removal and reinstallation of window. Owner must provide window's information and NOA, and evidence of permitting records.	SHEET 1-2/S3-104	80	EA	\$ 2,155.00	\$ 172,400.00	
	CR-10B	WINDOW SILL REPLACEMENT (Type A) - Precast window sill 4"by 8" removal and replacement . Sill extends 4-inches past window opening on both sides. Consider a 75-inch wide window. Includes removal and reinstallation of window. Owner must provide window's information and NOA, and evidence of permitting records.	SHEET 1-2/S3-104	10	EA	\$ 2,670.00	\$ 26,700.00	
	CR-10C	WINDOW SILL REPLACEMENT (Type C) - Precast window sill 4"by 8" removal and replacement . Sill extends 4-inches past window opening on both sides. Consider a 25-inch wide window. Includes removal and reinstallation of window. Owner must provide window's information and NOA, and evidence of permitting records.	SHEET 1-2/S3-104	4	EA	\$ 1,645.00	\$ 6,580.00	
	CR-11	CONCRETE TESTING: Provide third party concrete core testing for chlorides content and compression strenght	SPEC 014500	20	EA	\$ 498.00	\$ 9,960.00	
	CR-12	BREEZE WALL REPLACEMENT: Replace deteriorated breeze wall, to match existing. Include cementitious waterproofing on entire opening, with 8 inches return to the inside and outside walls. Consider each opening of 28x90 inches, or 28 pieces per opening.	S7-102	5	EA	\$ 7,950.00	\$ 39,750.00	
	CR Subtotal - Concrete Repairs						\$	1,312,975.00
	Stucco Repairs	ST-02	OVERHEAD SOFFIT STUCCO: Contractor shall remove and dispose of delaminated and/or damaged overhead soffit stucco. Contractor shall replace one-lift soffit stucco in accord with ASTM C926 and details/specifications. StoQuick Gold Soffit System preferred.	SPEC 92400 SHEET 7/S4-101	5,500	SF	\$ 31.00	\$ 170,500.00
		ST-03A	VERTICAL STUCCO: Contractor shall remove and dispose of delaminated and/or damaged vertical stucco on the tower envelope and balconies. Contractor shall replace two-lift wall stucco in accord with ASTM C926, details and specifications, including tuck-pointing.This is a two coat stucco.	SPEC 92400 SHEET 8/S4-101	10,800	SF	\$ 22.00	\$ 237,600.00
		ST-03B	VERTICAL STUCCO WITH BUILDOUT: Contractor shall remove and dispose of delaminated and/or damaged vertical wall stucco on the tower envelope and balconies. Contractor shall buildout and plumb misaligned substrate (assume 1" thickness) to insure stucco thickness does not exceed 5/8" section 039250. Contractor to replace two-lift wall stucco in accord with ASTM C926, details and specifications.	SPEC 39250 SHEET 9/S4-101	2,160	SF	\$ 27.10	\$ 58,536.00
ST-04		SUBSTRATE JOINTS: Contractor shall install 8" wide plastic lath strips at all joints of dissimilar materials in accord with ASTM C926, details and specifications. Contractor to include tuck pointing and stainless steel fasteners	SPEC 92400 SHEET 4/S4-101	6,750	LF	\$ 3.20	\$ 21,600.00	
ST-05		PARAPET RIBBON WALL: Contractor to install Sto RFP mesh stucco system on parapet exterior wall ribbon and underside ceiling in accord with ASTM C926. Include Sto Prime. Include stucco.	SPEC 92400 SHEET 8/S4-101	3,500	SF	\$ 33.25	\$ 116,375.00	
ST Subtotal - Stucco Repairs						\$	604,611.00	
Masonry Details	MR-01	MASONRY TUCK-POINTING REPAIRS: Repair deteriorated masonry components in accordance with TMS/ICRI guidelines, details and specifications. Work to include tuck-point between masonry runs, and at masonry/concrete transitions	SPEC 42200 SHEET 4/S3-301	1,500	LF	\$ 12.80	\$ 19,200.00	
	MR-02	MASONRY FACE REPAIRS: Repair deteriorated masonry components in accordance with TMS/ICRI guidelines, details and specifications. Work to include gel patching of block face. Consider a blocks/cell width of 8 inches.	SPEC 42200 SHEET 4/S3-301	200	EA	\$ 55.15	\$ 11,030.00	
	MR-03	MASONRY FILLED CELLS REPAIRS: Repair deteriorated masonry components in accordance with TMS/ICRI guidelines, details and specifications. Work to include replacement of deteriorated/missing steel, coating of exposed steel, surface prep, saw cutting, and grouting of empty cells. Consider a blocks/cell width of 8 inches.	SPEC 42200 SHEET 4/S3-301	200	EA	\$ 20.50	\$ 4,100.00	
	MR Subtotal - Masonry Repairs						\$	34,330.00
Base Bid Unit Price Total						\$	2,043,136.00	

Contractor is solely responsible for estimating quantities of all items listed as Lump Sum

SECTION 00300 - BID FORM
 BASE BID UNIT PRICES AND BID AMOUNTS
 OXFORD TOWERS 50-YEAR ENV.REST REV1
 BID FORM REVISION 1

BID COST SUMMARY

General Conditions I	\$	866,965.00
General Conditions II Passthrough Costs	\$	109,345.84
Base Bid Lump Sum Total	\$	2,657,191.00
Base Bid Unit Price Total	\$	2,043,136.00
Total Bid Price Estimate	\$	5,576,637.84

HURRICANES AND NAMED STORMS

	ITEM NO.	DESCRIPTION	Bid Quantity [A1]	PRICE	Unit
HURRICANES	H1	Hurricane Demobilization/Mobilization - Provide itemization of costs.	Each Occurrence	\$ 78,500.00	LS
	H2	Hurricane Demobilization - Provide estimated duration to demobilize the site in preparation for a hurricane.		5	DAYS
	H3	Hurricane ReMobilization - Provide estimated duration to remobilize the site.		6	DAYS

CONTRACT TIME DURATION	660	CALENDAR DAYS
Time/Material/Equipment Cost Plus	20	%

* NOTE: Any deviations from specified products must be specifically stated in the bid
 ** NOTE: Contractor to create mock-ups and receive written approval architect / engineer prior to the purchasing of materials for scope of work

Contractor is solely responsible for estimating quantities of all items listed as Lump Sum

CONTRACT TIME DURATION

Having taken fully into account all of the conditions set forth in the Agreement, Contractor agrees, without reservation to complete the Work, for all base bid and the estimated units described above, no later than 660 CALENDAR days after the receipt of Notice to Proceed for substantial completion.

SCHEDULE

1. The undersigned will submit in duplicate, at time of bid, a simplified Paragraph Schedule of the proposed Work under this Contract.
2. This proposal will remain in effect for a period of ninety (90) days from the time schedule for the submission of proposals.
3. The undersigned agrees to assume all increases in labor rates and/or material prices, which may develop during the life of this Contract. SEE ATTACHED QUALIFICATIONS/CLARIFICATIONS

BONDS

We have identified in the spaces below the cost of obtaining a Performance Bond and Labor and Material Payment Bond should it be made part of the Contract requirements.

Performance Bond

Labor and Material Bond

TOTAL

2.0 %

LABOR COST

Previously authorized LABOR COST work will be performed as provided in the General Conditions, except that the following rates shall apply.

1. Project Manager \$ 135 per hour
2. Project Supervision \$ 105 per hour
3. Skilled Carpenter \$ 85 per hour
4. Unskilled Labor \$ 75 per hour
5. Number of Crews on the Job \$ 2 crews - 7 men per crew
7. Time /Material/Equipment Cost Plus 20 %

PROVIDE AS NEEDED ON A TIME AND MATERIAL BASIS:

Any electrical/plumbing repairs requested to be performed by the CONTRACTOR must be pre-approved by the OWNER or ENGINEER and shall be billed as additional fees.

ASSIGNMENT

The undersigned represent that no assignment, sublease or transfer of all or any part of his interest in the proposal has been made or will be made without the prior written consent of the Owner.

BIDDING DOCUMENTS

The undersigned acknowledges receipt of the Scope of Work and bidding documents and affirms that all costs associated therewith are included in the base bid single lump sum. The undersigned declares, by executing this proposal, that

1. All requirements concerning licensing and all other local, state and Federal Laws have been or will be complied with before commencement of the Work and that no legal requirements will be violated in the execution of the Work if the proposal is accepted.
2. No person or persons or company or other entity other than the firm listed below or otherwise indicated hereinafter in writing to the Owner and acceptable to the Owner has any interest whatsoever in the proposal or the Contract that may be entered into as a result thereof. This proposal is submitted in good faith without collusion or fraud.

The person or persons signing this proposal is/are fully authorized to sign on behalf of the named firm and to fully bind the named firm to all of the conditions and provisions thereof.

Submitted this 12th day of May, 2023

Name of Firm Valcourt Exterior Building Services of Florida, L.C.

Street Address 4695 18th Street East

City Bradenton State FL Zip Code 34203

Telephone 941-747-7277 Fax 941-747-7277

Operating as (complete and strike out words that do not apply)

A Corporation under the Laws of the State of VIRGINIA

~~A Partnership (give full name and address of all partners)~~

~~An Individual~~

BY: Name Antonio Posadas

Signature 

Title Business Development Manager

Witness: 

Dated: May 12th, 2023

SUPERINTENDENT

The bidder's superintendent to be onsite for the work specified shall be listed in the space provided below. The superintendent listed shall be onsite during all work activities. The superintendent shall not be changed without approval from the Owner.

Contractor's Superintendent TBD



CERTIFICATE OF LIABILITY INSURANCE

DATE (MM/DD/YYYY)

2/24/2023

THIS CERTIFICATE IS ISSUED AS A MATTER OF INFORMATION ONLY AND CONFERS NO RIGHTS UPON THE CERTIFICATE HOLDER. THIS CERTIFICATE DOES NOT AFFIRMATIVELY OR NEGATIVELY AMEND, EXTEND OR ALTER THE COVERAGE AFFORDED BY THE POLICIES BELOW. THIS CERTIFICATE OF INSURANCE DOES NOT CONSTITUTE A CONTRACT BETWEEN THE ISSUING INSURER(S), AUTHORIZED REPRESENTATIVE OR PRODUCER, AND THE CERTIFICATE HOLDER.

IMPORTANT: If the certificate holder is an ADDITIONAL INSURED, the policy(ies) must have ADDITIONAL INSURED provisions or be endorsed. If SUBROGATION IS WAIVED, subject to the terms and conditions of the policy, certain policies may require an endorsement. A statement on this certificate does not confer rights to the certificate holder in lieu of such endorsement(s).

PRODUCER Alliant Insurance Services, Inc. 2000 West Loop South Ste 2150 Houston TX 77027	CONTACT NAME: Rachel Williams PHONE (A/C, No, Ext): 713-624-6343 E-MAIL ADDRESS: JASECOIS@alliant.com	FAX (A/C, No):
	INSURER(S) AFFORDING COVERAGE	
License# 0C36861 JOBSBU1-01	INSURER A : Old Republic Insurance Company INSURER B : Navigators Insurance Company INSURER C : Beazley Insurance Company, Inc INSURER D : Zurich American Insurance Comp INSURER E : Ironshore Specialty Insurance INSURER F :	NAIC # 24147 42307 37540 16535 25445

COVERAGES **CERTIFICATE NUMBER:** 1133811163 **REVISION NUMBER:**

THIS IS TO CERTIFY THAT THE POLICIES OF INSURANCE LISTED BELOW HAVE BEEN ISSUED TO THE INSURED NAMED ABOVE FOR THE POLICY PERIOD INDICATED. NOTWITHSTANDING ANY REQUIREMENT, TERM OR CONDITION OF ANY CONTRACT OR OTHER DOCUMENT WITH RESPECT TO WHICH THIS CERTIFICATE MAY BE ISSUED OR MAY PERTAIN, THE INSURANCE AFFORDED BY THE POLICIES DESCRIBED HEREIN IS SUBJECT TO ALL THE TERMS, EXCLUSIONS AND CONDITIONS OF SUCH POLICIES. LIMITS SHOWN MAY HAVE BEEN REDUCED BY PAID CLAIMS.

INSR LTR	TYPE OF INSURANCE	ADDL SUBR INSD WVD	POLICY NUMBER	POLICY EFF (MM/DD/YYYY)	POLICY EXP (MM/DD/YYYY)	LIMITS
A	<input checked="" type="checkbox"/> COMMERCIAL GENERAL LIABILITY <input type="checkbox"/> CLAIMS-MADE <input checked="" type="checkbox"/> OCCUR <input checked="" type="checkbox"/> Contractual Liab GEN'L AGGREGATE LIMIT APPLIES PER: <input type="checkbox"/> POLICY <input checked="" type="checkbox"/> PROJECT <input checked="" type="checkbox"/> LOC OTHER:	Y Y	MWZY31680023	3/1/2023	3/1/2024	EACH OCCURRENCE \$ 1,000,000 DAMAGE TO RENTED PREMISES (Ea occurrence) \$ 500,000 MED EXP (Any one person) \$ 10,000 PERSONAL & ADV INJURY \$ 1,000,000 GENERAL AGGREGATE \$ 2,000,000 PRODUCTS - COMP/OP AGG \$ 2,000,000 \$
A	<input checked="" type="checkbox"/> AUTOMOBILE LIABILITY <input checked="" type="checkbox"/> ANY AUTO <input type="checkbox"/> OWNED AUTOS ONLY <input type="checkbox"/> SCHEDULED AUTOS NON-OWNED AUTOS ONLY <input checked="" type="checkbox"/> HIRED AUTOS ONLY	Y Y	MWVB31680123	3/1/2023	3/1/2024	COMBINED SINGLE LIMIT (Ea accident) \$ 1,000,000 BODILY INJURY (Per person) \$ BODILY INJURY (Per accident) \$ PROPERTY DAMAGE (Per accident) \$ \$
B	<input checked="" type="checkbox"/> UMBRELLA LIAB <input checked="" type="checkbox"/> OCCUR <input type="checkbox"/> EXCESS LIAB <input type="checkbox"/> CLAIMS-MADE <input type="checkbox"/> DED <input checked="" type="checkbox"/> RETENTION \$ NIL	Y Y	CH23EXC836061IV	3/1/2023	3/1/2024	EACH OCCURRENCE \$ 10,000,000 AGGREGATE \$ 10,000,000 \$
A	WORKERS COMPENSATION AND EMPLOYERS' LIABILITY ANY PROPRIETOR/PARTNER/EXECUTIVE OFFICER/MEMBER EXCLUDED? (Mandatory in NH) If yes, describe under DESCRIPTION OF OPERATIONS below	Y N/A	MWC31679923	3/1/2023	3/1/2024	<input checked="" type="checkbox"/> PER STATUTE <input type="checkbox"/> OTHER E.L. EACH ACCIDENT \$ 1,000,000 E.L. DISEASE - EA EMPLOYEE \$ 1,000,000 E.L. DISEASE - POLICY LIMIT \$ 1,000,000
E C D	Contractors Pollution Crime Installation Floater		ICELLUW00119948 V2DACE220201 CPP4613156	3/1/2023 3/1/2023 1/1/2023	3/1/2024 3/1/2024 1/1/2024	Each Claim- \$25K Ded 2,000,000 Employee Theft 5,000,000 Installation/Service 500,000

DESCRIPTION OF OPERATIONS / LOCATIONS / VEHICLES (ACORD 101, Additional Remarks Schedule, may be attached if more space is required)
 The policy includes Blanket Additional Insured on the General Liability and Automobile with a Waiver of Subrogation on General Liability, Automobile and Workers Compensation when required by written contract. This insurance is Primary and Non-Contributory as respects to General Liability with respect to Additional Insured as required by written contract. Excess Liability will follow form with Underlying Insurance as respects Additional Insureds and Waiver of Subrogation.

CERTIFICATE HOLDER For Informational Purposes	CANCELLATION SHOULD ANY OF THE ABOVE DESCRIBED POLICIES BE CANCELLED BEFORE THE EXPIRATION DATE THEREOF, NOTICE WILL BE DELIVERED IN ACCORDANCE WITH THE POLICY PROVISIONS.
	AUTHORIZED REPRESENTATIVE 

© 1988-2015 ACORD CORPORATION. All rights reserved.



Ron DeSantis, Governor

Melanie S. Griffin, Secretary



**STATE OF FLORIDA
DEPARTMENT OF BUSINESS AND PROFESSIONAL REGULATION**

CONSTRUCTION INDUSTRY LICENSING BOARD

THE GENERAL CONTRACTOR HEREIN IS CERTIFIED UNDER THE
PROVISIONS OF CHAPTER 489, FLORIDA STATUTES

VANHOY, MICHAEL D

VALCOURT EXTERIOR BUILDING SERVICES OF FLORIDA LC
4695 18TH STREET EAST
BRADENTON FL 34203

LICENSE NUMBER: CGC1514034

EXPIRATION DATE: AUGUST 31, 2024

Always verify licenses online at MyFloridaLicense.com



Do not alter this document in any form.

This is your license. It is unlawful for anyone other than the licensee to use this document.

GENERAL CLIENT PREQUALIFICATION LETTER

February 22, 2023

Re: Valcourt Building Services LC and Affiliates

To Whom It May Concern:

Berkley Insurance Company a corporation under the laws of the State of Delaware, with an office and place of business located at 475 Steamboat Road, Greenwich, CT 06830, represents Valcourt Building Services LC and Affiliates for its surety bonding needs. As of the date of this writing, Valcourt Building Services LC and Affiliates remains in good standing with Berkley Insurance Company, which is affording continued surety credit for bonded obligations with single project sizes up to \$10,000,000 within an aggregate bonded surety program of \$30,000,000.

This letter is not to be construed as an agreement to provide surety bonds for any particular project, but is offered as an indication of Berkley Insurance Company's past experience and confidence in the firm. Berkley Insurance Company reserves the right to review terms and conditions of any proposals, contract documents, bond forms, financial arrangements and other underwriting considerations at the time the contract is awarded.

If you have any questions or need any additional information, please do not hesitate to contact me.

Sincerely,

April D. Perez

April D. Perez, Attorney-In-Fact
Berkley Insurance Company

A+ (Superior) by A. M. Best Financial Size Category XV (\$2 Billion or greater)



603 N. 21st Avenue • Hollywood, FL 33020
Tel: (305) 758-2000 Fax: (305) 754-1333

Proposal Submitted to:

Oxford Towers
1501 S. Ocean Dr.
Hollywood, FL 33019

Tel / Email:

(786)410-6727 / campropmgr2@outlook.com

Attn: Ana Gutierrez

Job Name:

Repipe and Install New Turtle Light Fixtures on 94 Balconies

Location:

Same

Job Description:

- | | |
|---|---------------------|
| 1.) Removal of existing metallic boxes and associated as per sheet E.06. | QUOTE: \$65,000.00 |
| 2.) Provide and install conduit wall box and connect back as per sheet E-07. | QUOTE: \$67,200.00 |
| 3.) Installation of new wall sconce and associated conduit as per sheet E-08. | QUOTE: \$55,000.00 |
| 4.) Removal and replacement of existing GFCI receptacle as per sheet E-09. | QUOTE : \$25,850.00 |
| 5.) All conduit, wiring, miscellaneous materials and labor included. | |

Notes:

- Patching and painting if required, is by others at owners expense.
- No permit included.
- Any additional services required by the Authorities Having Jurisdiction will be considered a change to the scope and will be quoted as a change.

WE PROPOSE hereby to furnish material and labor - complete in accordance with these specifications for the sum of
See Above

Payable as follows: 20% Down Payment, Progress Payments

In the event customer fails to pay this proposal when due, Moody Electric, Inc. shall be entitled to recover all costs incurred including attorney's fees for services rendered in connection with collection of payment of the debt as evidence by this proposal or enforcement of Moody Electric Inc.'s rights provided under law.

INCREASES IN MATERIAL COST. In the event that, during construction of the improvement described herein, contractor's costs for materials used or to be used herein are increased by more than 10% over the contractor's costs for the same at the time this agreement was signed, for any cause(s) beyond the control of contractor, then, and in such event(s), contractor shall have the right to pass the entire amount of material costs increase(s) along to owner by adding the total amount(s) thereof to the Contract Price.

Moody Electric, Inc. Authorized Signature

QUOTED BY: Barney Moody
LIC #22E000393

Acceptance of Proposal - The prices, specifications and conditions are satisfactory and are hereby accepted. You are authorized to do the work specified. Payment will be made as outlined above.

Signature _____ Date _____ Signature _____ Date _____

Print _____ Print _____

A-Best Painting Contractors

2112 S.W. 58th Avenue - West Park, Florida 33023

Licensed & Insured

Broward: CC#20-PU-21964-X - Dade: CC#20BS00497

Phone: 954-987-6062 – Fax: 1954-628-5029

Web: WWW.ABESTPAINTING.COM



A-Best Painting Contractors, a Commercial and Residential painting business serving South Florida for over 30 years. We are made up of a diligent office staff and crews of dedicated and professional painters.

The A-Best Painting Contractors staff has plenty of experience, not only in painting and pressure cleaning but are adept in office buildings, condo building painting and homes (both interior and exterior). Textures, wallpaper removal & installation, stucco work, exterior houses, as well as the most intricate of custom interiors such as faux finish, venetian plaster, custom murals, and mural restoration. We promise a clean, solid, professional job done right the first time. No excuses, if you want an A-Best job, we will make you a happy customer.

Most importantly, each job contracted by A-Best Painting Contractors will have a supervisor or an experienced foreman in charge and office staff available for consultations daily. This will ensure that you receive maximum efficiency and that the correct materials are applied to the right places. That on-the-job supervision keeps everyone happy, the customer and us the contractor. All our painters are dressed in uniform, well-mannered and well supervised. We will be happy to supply up to date insurance forms and references from our many happy customers. Remember, A-Best Painting has been serving South Florida for over 3 decades, this is how we have achieved an **“A” Rating with Angie’s List, and the Better Business Bureau and a “5 Star Rating” on Google (feel free to view our customer references).**

Our estimates are provided at no charge or obligation. We give competitive and professional quotes. Please call our office any time for your immediate and future painting project. We thank you for your time and look forward to your calls.

Wishing you an A-Best 2024.

Sincerely,

A-Best Painting Contractors
2112 S.W. 58th Avenue - West Park, Florida 33023
Licensed & Insured
Broward: CC#20-PU-21964-X, Dade: CC#20BS00497
Phone: 954-987-6062 – Fax: 1954-628-5029
Web: www.abestpainting.com



-----Proposal-----

11/28/2023

Oxford Tower
1501 S. Ocean Drive Hollywood, Fl. 33019
C/O: Sindia Baptiste - Phone: 786-410-6727
Email: iromyamericanmgmtgroup@gmail.com

Project Description:

SIXTEEN-STORY RESIDENTIAL BUILDING INTERIOR

Scope of work:

**1st Floor Lobby Area, Mail Area, Sauna Room, Rec Room & Kitchen,
Cart Room, Men's Room, Lady's Room & Hallways.**

2nd Floor and All Floors Up to PH (15 Floors Total) Hallways.

Walls- in all areas listed above.

Ceilings- in lobby, sauna, all hallways from 2nd floor up to PH.

277 Doors & Frames- in areas listed above (hallway side only, 1 solid color).

Standard preparation:

Walls & Ceilings-Patch minor holes and cracks, sand as needed. Seal any stains to help prevent bleed thru then repaint using a Sherwin Williams Super Paint (or equal) interior acrylic latex to a desired color and finish.

Doors & frames- putty any holes, caulk all openings, sand as needed. Repaint using a top-of-the-line Sherwin Williams Super Paint (or equal) interior enamel to a desired color and finish.

SOLID COVERAGE GUARANTEED ON ALL SURFACES

Omit/Not included:

All stairways, elevator doors & frames, fire extinguisher boxes, all acoustical ceilings, all tile bases, lobby mural wall, any major patching unless specified above and anything not listed.

Our Promise
"We Do It Right the First Time".

-----*Proposal*-----

11/28/2023

Colors:

Per Customer's choice

Schedule:

Approx. Project Duration: 4-6 weeks

Insurance:

Available upon request.

Service Warranty:

2-year job workmanship.

Total for all above Labor & Materials

Total	Deposit	Completion	After Walk-through
\$66,444.00	\$33,222.00	\$26,577.60	\$6,644.40

Payments to be made as follows: 50% deposit required; 40% due on completion; 10% balance due after walk-through.

Customer agrees to pay interest at the highest legal rate on any outstanding balance remaining after thirty (30) days from date of completion and further agrees to pay all costs of collection of any such balance including reasonable attorney's fees.

Most cities do not require permits for painting. This proposal does not include permit fees, condo fees, association fees and any additional unknown city requirements.

Does not include any asbestos removal, lead paint removal or lead restoration.

ACCEPTANCE OF PROPOSAL

The above prices, specifications and conditions are satisfactory and are hereby accepted.

You are authorized to do the work as specified. Payment will be made as outlined above.

NOTE: This proposal is deemed withdrawn by us if not accepted within 30 days from the date of this proposal.

Date: _____

Signature: _____

I have read and approved this order; it is non-cancellable.

A-BEST Painting Contractors – Authorized Representative

BROWARD COUNTY LOCAL BUSINESS TAX RECEIPT

115 S. Andrews Ave., Rm. A-100, Ft. Lauderdale, FL 33301-1895 – 954-357-4829

VALID OCTOBER 1, 2023 THROUGH SEPTEMBER 30, 2024

DBA: A- BEST PAINTING CONTRACTORS
Business Name: COEUR HOLDINGS LLC

Receipt #: 184-389
Business Type: PAINTING/SEALCOAT/CONTRACTOR
(PAINTING CONTR)

Owner Name: COEUR, VLADIMIR
Business Location: 2112 SW 58 AVE
WEST PARK
Business Phone: 954-987-6062

Business Opened: 12/13/1985
State/County/Cert/Reg: 20-PU-21964-X
Exemption Code:

Rooms **Seats** **Employees** **Machines** **Professionals**
9

		For Vending Business Only					
		Number of Machines:		Vending Type:			
Tax Amount	Transfer Fee	NSF Fee	Penalty	Prior Years	Collection Cost	Total Paid	
27.00	0.00	0.00	0.00	0.00	0.00	27.00	

Receipt Fee 27.00
Packing/Processing/Canning Employees 0.00

THIS RECEIPT MUST BE POSTED CONSPICUOUSLY IN YOUR PLACE OF BUSINESS

**THIS BECOMES A TAX RECEIPT
WHEN VALIDATED**

This tax is levied for the privilege of doing business within Broward County and is non-regulatory in nature. You must meet all County and/or Municipality planning and zoning requirements. This Business Tax Receipt must be transferred when the business is sold, business name has changed or you have moved the business location. This receipt does not indicate that the business is legal or that it is in compliance with State or local laws and regulations.

Mailing Address:

COEUR HOLDINGS LLC
2112 SW 58 AVE
WEST PARK, FL 33023-0000

Receipt # WWW-22-00248095
Paid 07/03/2023 27.00

2023 - 2024

BROWARD COUNTY LOCAL BUSINESS TAX RECEIPT

115 S. Andrews Ave., Rm. A-100, Ft. Lauderdale, FL 33301-1895 – 954-357-4829

VALID OCTOBER 1, 2023 THROUGH SEPTEMBER 30, 2024

DBA: A- BEST PAINTING CONTRACTORS
Business Name: COEUR HOLDINGS LLC

Receipt #: 184-389
Business Type: PAINTING/SEALCOAT/CONTRACTOR
(PAINTING CONTR)

Owner Name: COEUR, VLADIMIR
Business Location: 2112 SW 58 AVE
WEST PARK
Business Phone: 954-987-6062

Business Opened: 12/13/1985
State/County/Cert/Reg: 20-PU-21964-X
Exemption Code:

Rooms **Seats** **Employees** **Machines** **Professionals**
9

Signature		For Vending Business Only					
		Number of Machines:		Vending Type:			
Tax Amount	Transfer Fee	NSF Fee	Penalty	Prior Years	Collection Cost	Total Paid	
27.00	0.00	0.00	0.00	0.00	0.00	27.00	

Receipt # WWW-22-00248095
Paid 07/03/2023 27.00

Local Business Tax Receipt

Miami-Dade County, State of Florida

-THIS IS NOT A BILL - DO NOT PAY



1546887

RECEIPT NO.

RENEWAL

1546887

BUSINESS NAME/LOCATION
A BEST PAINTING
CONTRACTORS
DOING BUSINESS IN DADE
COUNTY



EXPIRES
SEPTEMBER 30, 2024

Must be displayed at place of business
Pursuant to County Code
Chapter 8A - Art. 9 & 10

OWNER
COEUR HOLDINGS LLC
C/O VLADIMIR COEUR QUALIFIER

SEC. TYPE OF BUSINESS

196 SPECIALTY BUILDING
CONTRACTOR

**PAYMENT RECEIVED
BY TAX COLLECTOR**

75.00 07/03/2023

Worker(s) 10

20BS00497

INT-23-382809

This Local Business Tax Receipt only confirms payment of the Local Business Tax. The Receipt is not a license, permit, or a certification of the holder's qualifications, to do business. Holder must comply with any governmental or nongovernmental regulatory laws and requirements which apply to the business.

The RECEIPT NO. above must be displayed on all commercial vehicles - Miami-Dade Code Sec 8a-276.

For more information, visit www.miamidade.gov/taxcollector





CERTIFICATE OF LIABILITY INSURANCE

Acct#: 3032649

DATE (MM/DD/YYYY)

12/31/2023

THIS CERTIFICATE IS ISSUED AS A MATTER OF INFORMATION ONLY AND CONFERS NO RIGHTS UPON THE CERTIFICATE HOLDER. THIS CERTIFICATE DOES NOT AFFIRMATIVELY OR NEGATIVELY AMEND, EXTEND OR ALTER THE COVERAGE AFFORDED BY THE POLICIES BELOW. THIS CERTIFICATE OF INSURANCE DOES NOT CONSTITUTE A CONTRACT BETWEEN THE ISSUING INSURER(S), AUTHORIZED REPRESENTATIVE OR PRODUCER, AND THE CERTIFICATE HOLDER.

IMPORTANT: If the certificate holder is an ADDITIONAL INSURED, the policy(ies) must have ADDITIONAL INSURED provisions or be endorsed. If SUBROGATION IS WAIVED, subject to the terms and conditions of the policy, certain policies may require an endorsement. A statement on this certificate does not confer rights to the certificate holder in lieu of such endorsement(s).

PRODUCER Aon Risk Services South, Inc 3550 LENOX ROAD NORTHEAST, SUITE 1700 ATLANTA, GA 30326	CONTACT NAME: PHONE (A/C, No, Ext): 844-398-0470		FAX (A/C, No):
	E-MAIL ADDRESS: TPGcerts@locktonaffinity.com		
INSURED Coeur Holdings LLC dba A-Best Painting Contractors 2112 SW 58th Avenue West Park FL 33023	INSURER(S) AFFORDING COVERAGE		NAIC #
	INSURER A : Indemnity Insurance Co. of North America		43575
	INSURER B :		
	INSURER C :		
	INSURER D :		
	INSURER E :		

COVERAGES **CERTIFICATE NUMBER:** **REVISION NUMBER:**

THIS IS TO CERTIFY THAT THE POLICIES OF INSURANCE LISTED BELOW HAVE BEEN ISSUED TO THE INSURED NAMED ABOVE FOR THE POLICY PERIOD INDICATED. NOTWITHSTANDING ANY REQUIREMENT, TERM OR CONDITION OF ANY CONTRACT OR OTHER DOCUMENT WITH RESPECT TO WHICH THIS CERTIFICATE MAY BE ISSUED OR MAY PERTAIN, THE INSURANCE AFFORDED BY THE POLICIES DESCRIBED HEREIN IS SUBJECT TO ALL THE TERMS, EXCLUSIONS AND CONDITIONS OF SUCH POLICIES. LIMITS SHOWN MAY HAVE BEEN REDUCED BY PAID CLAIMS.

INSR LTR	TYPE OF INSURANCE	ADDL INSD	SUBR WVD	POLICY NUMBER	POLICY EFF (MM/DD/YYYY)	POLICY EXP (MM/DD/YYYY)	LIMITS
	COMMERCIAL GENERAL LIABILITY <input type="checkbox"/> CLAIMS-MADE <input type="checkbox"/> OCCUR GEN'L AGGREGATE LIMIT APPLIES PER: <input type="checkbox"/> POLICY <input type="checkbox"/> PRO-JECT <input type="checkbox"/> LOC OTHER:						EACH OCCURRENCE \$ DAMAGE TO RENTED PREMISES (Ea occurrence) \$ MED EXP (Any one person) \$ PERSONAL & ADV INJURY \$ GENERAL AGGREGATE \$ PRODUCTS - COMP/OP AGG \$ \$
	AUTOMOBILE LIABILITY <input type="checkbox"/> ANY AUTO <input type="checkbox"/> ALL OWNED AUTOS <input type="checkbox"/> HIRED AUTOS <input type="checkbox"/> SCHEDULED AUTOS <input type="checkbox"/> NON-OWNED AUTOS						COMBINED SINGLE LIMIT (Ea accident) \$ BODILY INJURY (Per person) \$ BODILY INJURY (Per accident) \$ PROPERTY DAMAGE (Per accident) \$ \$
	UMBRELLA LIAB <input type="checkbox"/> OCCUR EXCESS LIAB <input type="checkbox"/> CLAIMS-MADE DED RETENTION \$						EACH OCCURRENCE \$ AGGREGATE \$ \$
A	WORKERS COMPENSATION AND EMPLOYERS' LIABILITY ANY PROPRIETOR/PARTNER/EXECUTIVE OFFICER/MEMBER EXCLUDED? (Mandatory in NH) if yes, describe under DESCRIPTION OF OPERATIONS below	Y/N	N/A	C57196725	12/31/2023	12/31/2024	<input checked="" type="checkbox"/> PER STATUTE <input type="checkbox"/> OTH-ER E.L. EACH ACCIDENT \$ 1,000,000 E.L. DISEASE - EA EMPLOYEE \$ 1,000,000 E.L. DISEASE - POLICY LIMIT \$ 1,000,000

DESCRIPTION OF OPERATIONS / LOCATIONS / VEHICLES (ACORD 101, Additional Remarks Schedule, may be attached if more space is required)

CERTIFICATE HOLDER

CANCELLATION

Proof of coverage:
 Coeur Holdings LLC dba A-Best Painting Contractors
 2112 SW 58th Ave
 West Park FL 33023

SHOULD ANY OF THE ABOVE DESCRIBED POLICIES BE CANCELLED BEFORE THE EXPIRATION DATE THEREOF, NOTICE WILL BE DELIVERED IN ACCORDANCE WITH THE POLICY PROVISIONS.

AUTHORIZED REPRESENTATIVE



CERTIFICATE OF LIABILITY INSURANCE

DATE (MM/DD/YYYY)
01/19/2024

THIS CERTIFICATE IS ISSUED AS A MATTER OF INFORMATION ONLY AND CONFERS NO RIGHTS UPON THE CERTIFICATE HOLDER. THIS CERTIFICATE DOES NOT AFFIRMATIVELY OR NEGATIVELY AMEND, EXTEND OR ALTER THE COVERAGE AFFORDED BY THE POLICIES BELOW. THIS CERTIFICATE OF INSURANCE DOES NOT CONSTITUTE A CONTRACT BETWEEN THE ISSUING INSURER(S), AUTHORIZED REPRESENTATIVE OR PRODUCER, AND THE CERTIFICATE HOLDER.

IMPORTANT: If the certificate holder is an ADDITIONAL INSURED, the policy(ies) must have ADDITIONAL INSURED provisions or be endorsed. If SUBROGATION IS WAIVED, subject to the terms and conditions of the policy, certain policies may require an endorsement. A statement on this certificate does not confer rights to the certificate holder in lieu of such endorsement(s).

PRODUCER Huntsberger Enterprises Inc DbA Solution Providers 639 East Ocean Ave Suite 109 Boynton Beach, FL 33435 License #: L116201	CONTACT NAME: Mathew Cary Giles Huntsberger
	PHONE (A/C, No, Ext): (866)420-3834 FAX (A/C, No): (561)903-2718
	E-MAIL ADDRESS: mat@peosolutionproviders.com
	INSURER(S) AFFORDING COVERAGE
	INSURER A: Sutton Specialty Insurance Company NAIC # 25798
	INSURER B:
	INSURER C:
	INSURER D:
	INSURER E:
	INSURER F:

INSURED
COEUR HOLDINGS LLC
DBA A-BEST PAINTING CONTRACTORS
2112 SW 58TH AVENUE
WEST PARK, FL 33023

COVERAGES CERTIFICATE NUMBER: 0000085-0 REVISION NUMBER: 1

THIS IS TO CERTIFY THAT THE POLICIES OF INSURANCE LISTED BELOW HAVE BEEN ISSUED TO THE INSURED NAMED ABOVE FOR THE POLICY PERIOD INDICATED. NOTWITHSTANDING ANY REQUIREMENT, TERM OR CONDITION OF ANY CONTRACT OR OTHER DOCUMENT WITH RESPECT TO WHICH THIS CERTIFICATE MAY BE ISSUED OR MAY PERTAIN, THE INSURANCE AFFORDED BY THE POLICIES DESCRIBED HEREIN IS SUBJECT TO ALL THE TERMS, EXCLUSIONS AND CONDITIONS OF SUCH POLICIES. LIMITS SHOWN MAY HAVE BEEN REDUCED BY PAID CLAIMS.

INSR LTR	TYPE OF INSURANCE	ADDL INSD	SUBR WVD	POLICY NUMBER	POLICY EFF (MM/DD/YYYY)	POLICY EXP (MM/DD/YYYY)	LIMITS
A	<input checked="" type="checkbox"/> COMMERCIAL GENERAL LIABILITY <input type="checkbox"/> CLAIMS-MADE <input checked="" type="checkbox"/> OCCUR GEN'L AGGREGATE LIMIT APPLIES PER: <input checked="" type="checkbox"/> POLICY <input type="checkbox"/> PRO-JECT <input type="checkbox"/> LOC OTHER:			ISCP0400001996	12/24/2023	12/24/2024	EACH OCCURRENCE \$ 1,000,000 DAMAGE TO RENTED PREMISES (Ea occurrence) \$ 50,000 MED EXP (Any one person) \$ 5,000 PERSONAL & ADV INJURY \$ 1,000,000 GENERAL AGGREGATE \$ 2,000,000 PRODUCTS - COMP/OP AGG \$ 2,000,000
	AUTOMOBILE LIABILITY ANY AUTO <input type="checkbox"/> OWNED AUTOS ONLY <input type="checkbox"/> SCHEDULED AUTOS <input type="checkbox"/> HIRED AUTOS ONLY <input type="checkbox"/> NON-OWNED AUTOS ONLY						COMBINED SINGLE LIMIT (Ea accident) \$ BODILY INJURY (Per person) \$ BODILY INJURY (Per accident) \$ PROPERTY DAMAGE (Per accident) \$
	UMBRELLA LIAB <input type="checkbox"/> OCCUR EXCESS LIAB <input type="checkbox"/> CLAIMS-MADE DED RETENTION \$						EACH OCCURRENCE \$ AGGREGATE \$
	WORKERS COMPENSATION AND EMPLOYERS' LIABILITY ANY PROPRIETOR/PARTNER/EXECUTIVE OFFICER/MEMBER EXCLUDED? (Mandatory in NH) If yes, describe under DESCRIPTION OF OPERATIONS below						PER STATUTE <input type="checkbox"/> OTH-ER <input type="checkbox"/> E.L. EACH ACCIDENT \$ E.L. DISEASE - EA EMPLOYEE \$ E.L. DISEASE - POLICY LIMIT \$

DESCRIPTION OF OPERATIONS / LOCATIONS / VEHICLES (ACORD 101, Additional Remarks Schedule, may be attached if more space is required)

Coeur Holdings LLC DBA A-Best Painting Contractors Is A Certificate Holder On The General Liability Insurance.

CERTIFICATE HOLDER Coeur Holdings LLC DBA A-Best Painting Contractors 2112 SW 58th Avenue, West Park, Florida. 33023	CANCELLATION SHOULD ANY OF THE ABOVE DESCRIBED POLICIES BE CANCELLED BEFORE THE EXPIRATION DATE THEREOF, NOTICE WILL BE DELIVERED IN ACCORDANCE WITH THE POLICY PROVISIONS. AUTHORIZED REPRESENTATIVE <i>Mathew Huntsberger</i>
--	--



CERTIFICATE OF LIABILITY INSURANCE

DATE (MM/DD/YYYY)

01/23/2024

THIS CERTIFICATE IS ISSUED AS A MATTER OF INFORMATION ONLY AND CONFERS NO RIGHTS UPON THE CERTIFICATE HOLDER. THIS CERTIFICATE DOES NOT AFFIRMATIVELY OR NEGATIVELY AMEND, EXTEND OR ALTER THE COVERAGE AFFORDED BY THE POLICIES BELOW. THIS CERTIFICATE OF INSURANCE DOES NOT CONSTITUTE A CONTRACT BETWEEN THE ISSUING INSURER(S), AUTHORIZED REPRESENTATIVE OR PRODUCER, AND THE CERTIFICATE HOLDER.

IMPORTANT: If the certificate holder is an ADDITIONAL INSURED, the policy(ies) must have ADDITIONAL INSURED provisions or be endorsed. If SUBROGATION IS WAIVED, subject to the terms and conditions of the policy, certain policies may require an endorsement. A statement on this certificate does not confer rights to the certificate holder in lieu of such endorsement(s).

PRODUCER RSC Insurance Brokerage, Inc. 3250 N. 29th Avenue Hollywood FL 33020	CONTACT NAME: Shelley Oesterling PHONE (A/C, No, Ext): (954) 416-9862 E-MAIL ADDRESS: soesterling@risk-strategies.com	FAX (A/C, No):
	INSURER(S) AFFORDING COVERAGE	
INSURED Coeur Holdings, LLC A Best Painting 13162 SW 45th Dr Miramar FL 33027	INSURER A: Progressive Express Insurance Company INSURER B: INSURER C: INSURER D: INSURER E: INSURER F:	
	NAIC # 10193	

COVERAGES

CERTIFICATE NUMBER: CL2411112926

REVISION NUMBER:

THIS IS TO CERTIFY THAT THE POLICIES OF INSURANCE LISTED BELOW HAVE BEEN ISSUED TO THE INSURED NAMED ABOVE FOR THE POLICY PERIOD INDICATED. NOTWITHSTANDING ANY REQUIREMENT, TERM OR CONDITION OF ANY CONTRACT OR OTHER DOCUMENT WITH RESPECT TO WHICH THIS CERTIFICATE MAY BE ISSUED OR MAY PERTAIN, THE INSURANCE AFFORDED BY THE POLICIES DESCRIBED HEREIN IS SUBJECT TO ALL THE TERMS, EXCLUSIONS AND CONDITIONS OF SUCH POLICIES. LIMITS SHOWN MAY HAVE BEEN REDUCED BY PAID CLAIMS.

INSR LTR	TYPE OF INSURANCE	ADDL INSD	SUBR WVD	POLICY NUMBER	POLICY EFF (MM/DD/YYYY)	POLICY EXP (MM/DD/YYYY)	LIMITS
	COMMERCIAL GENERAL LIABILITY <input type="checkbox"/> CLAIMS-MADE <input type="checkbox"/> OCCUR GEN'L AGGREGATE LIMIT APPLIES PER: <input type="checkbox"/> POLICY <input type="checkbox"/> PRO-JECT <input type="checkbox"/> LOC OTHER:						EACH OCCURRENCE \$ DAMAGE TO RENTED PREMISES (Ea occurrence) \$ MED EXP (Any one person) \$ PERSONAL & ADV INJURY \$ GENERAL AGGREGATE \$ PRODUCTS - COMP/OP AGG \$ \$
A	AUTOMOBILE LIABILITY <input type="checkbox"/> ANY AUTO <input type="checkbox"/> OWNED AUTOS ONLY <input type="checkbox"/> HIRED AUTOS ONLY <input checked="" type="checkbox"/> SCHEDULED AUTOS <input type="checkbox"/> NON-OWNED AUTOS ONLY			956895648	03/24/2023	03/24/2024	COMBINED SINGLE LIMIT (Ea accident) \$ BODILY INJURY (Per person) \$ 100,000 BODILY INJURY (Per accident) \$ 300,000 PROPERTY DAMAGE (Per accident) \$ 50,000 \$
	UMBRELLA LIAB <input type="checkbox"/> OCCUR EXCESS LIAB <input type="checkbox"/> CLAIMS-MADE DED RETENTION \$						EACH OCCURRENCE \$ AGGREGATE \$ \$
	WORKERS COMPENSATION AND EMPLOYERS' LIABILITY ANY PROPRIETOR/PARTNER/EXECUTIVE OFFICER/MEMBER EXCLUDED? (Mandatory in NH) If yes, describe under DESCRIPTION OF OPERATIONS below			N/A			PER STATUTE OTH-ER E.L. EACH ACCIDENT \$ E.L. DISEASE - EA EMPLOYEE \$ E.L. DISEASE - POLICY LIMIT \$

DESCRIPTION OF OPERATIONS / LOCATIONS / VEHICLES (ACORD 101, Additional Remarks Schedule, may be attached if more space is required)

Proof of Insurance Only.

CERTIFICATE HOLDER**CANCELLATION**

Coeur Holdings LLC dba A-Best Painting Contractors 2112 SW 58th Ave West Park FL 33023	SHOULD ANY OF THE ABOVE DESCRIBED POLICIES BE CANCELLED BEFORE THE EXPIRATION DATE THEREOF, NOTICE WILL BE DELIVERED IN ACCORDANCE WITH THE POLICY PROVISIONS. AUTHORIZED REPRESENTATIVE
---	--

© 1988-2015 ACORD CORPORATION. All rights reserved.



Estimate

2304-0410-6479

2024-04-21

M&A Professional Painting
 Alon Wolkowitz
 Alon@maprofessionalpainting.com
 954-516-9326

AMERICAN MANAGEMENT GROUP - Teresa
 Hernando
 1501 S. Ocean Dr
 Hollywood FL 33019
 csr@americanmgmtgroup.com
 (786) 410-6727

Oxford Towers
 1501 S. Ocean Dr, Hollywood, FL, 33019

Interior Painting

<i>Description</i>	<i>Total</i>
<u>Interior Paint Manufacturer</u>	
<ul style="list-style-type: none"> • PPG Diamond • SW Superpaint • We only use the top quality paints from leading manufacturers to ensure the highest quality finish. 	
<u>Interior Repairs</u>	
Repair all minor holes, cracks and gouges with compound and/or caulking	
<u>Interior Prep Sand</u>	
Light sand over any surfaces necessary to ensure a quality finish	
<u>Interior Finish Repaint</u>	
Repaint over existing walls & ceilings	
<ul style="list-style-type: none"> • First floor • Floors 2 - PH (Hallways) • 2 Bathrooms • Recreation room • Kitchen • Mail room • Sauna • Cart room • Lobby • Trash rooms 	
<ul style="list-style-type: none"> • Approximately 40,000 sq ft of paintable space 	
	\$66,402.00

Interior Painting - Doors

<i>Description</i>	<i>Total</i>
--------------------	--------------

Interior Finish Repaint

- Repaint over existing doors and trim (240 doors)
 - Semi gloss waterborne alkyd enamel
-

\$11,520.00

Subtotal \$77,922.00
Tax \$0.00
Total \$77,922.00

- Potential unforeseen repairs, renovations or demolition, may be needed. These are not included in the above scope of work unless stated in the quote above (for example, mold behind wallpaper)
- M&A Professional Painting will put a max of 2 coats of paint, any additional will be charged accordingly.
- We allow up to 3 colors included, any additional color will be \$50 each.
- Satin/Eggshell \$3/gallon additional.
- Doors: If it is found oil has been painted over latex additional stripping charges will be added
- Unless explicitly stated no other substrates will be painted without a change work order.
- Often the question of a garage arises during an estimate for interior painting. Unless it is explicitly stated, we do not include the garage in our proposals.
- This estimate is based on current market prices of necessary materials and present rates for the labor that will be required.
- Accordingly, this estimate will need to be revised if you decide not to enter a contract with M&A Professional Painting within the next 15 days.
- <https://pcapainted.org/wp-content/uploads/2019/05/PDCA-Standards-May28-2019.pdf>
 - 2.6. The painting and decorating contractor will produce a “properly painted surface.” A “properly painted surface” is defined as uniform in appearance, color, texture, hiding and sheen. It is also free of foreign material, lumps, skins, runs, sags, holidays, misses, or insufficient coverage. It is also a surface free of drips, spatters, spills or overspray caused by the painting and decorating contractor’s workforce. In order to determine whether a surface has been “properly painted” it shall be examined without magnification at a distance of thirty-nine (39) inches or one (1) meter, or more, under finished lighting conditions and from a normal viewing position.
- In the event that any suit or action is instituted to enforce any provision in this Agreement, M&A Professional Painting shall be entitled to recover from the opposing party all fees, costs and expenses of enforcing any right under or with respect to this Agreement, including without limitation, such reasonable fees and expenses of attorneys and accountants, which shall include, without limitation, all fees, costs and expenses of appeals.
- We do not set hard deadlines. Weather, illness, accidents, Covid, personnel issues, car trouble, etc. can all cause delays. We try our hardest to finish as quickly and professionally as possible but delays occur and we will not be held responsible if you need to make other accommodations.
- Deposits are 33%, progress payments are taken upon approximate halfway mark - additional 50% and final payment upon completion and walkthrough with owner. Larger projects will have a payment schedule agreed upon before commencing work.
- Payment in full is required upon completion, there will be a \$50/day late fee. It is the customer responsibility to be available to do the final walkthrough upon completed work. Depending on

the project size, we give you a few hours notice. Virtual walkthroughs are offered if you are unable to be there in person.

- Customer is required to choose the color. We are not responsible if you don't like the finished product, we will charge accordingly for repainting.
- All colors look slightly different depending on room size and lighting and customer is responsible to request a sample if they are not sure. Buying and applying samples are \$20 each.
- Cancellation: No refunds after deposit is submitted.
- 1 free hour of touch ups - every year for 3 years. 2024 - 2026*
 - (residential repaints only)
- Upon acceptance of deposit we will provide a sample of the paint with the agreed upon color and paint it into an area of your home. Upon sign off, the customer is responsible for the color choice which may vary slightly in different parts of the home due to lighting and sun, other home features such as tiles, furniture, etc. Slight color deviations when color matching are natural. If you require a specific manufacturer additional costs can be assessed. If customer is out of town, approval from photos or a proxy is acceptance in full.
- If a sales acknowledgment, invoice, Purchase Order, or other document submitted by either Party contains terms or conditions conflicting with or additional to the terms and conditions of this Agreement, the Parties hereby reject such terms and conditions, and the terms and conditions of this Agreement will prevail.
- ACCORDING TO FLORIDA'S CONSTRUCTION LIEN LAW (SECTIONS 713.001-713.37, FLORIDA STATUTES), THOSE WHO WORK ON YOUR PROPERTY OR PROVIDE MATERIALS AND SERVICES AND ARE NOT PAID IN FULL HAVE A RIGHT TO ENFORCE THEIR CLAIM FOR PAYMENT AGAINST YOUR PROPERTY. THIS CLAIM IS KNOWN AS A CONSTRUCTION LIEN. IF YOUR CONTRACTOR OR A SUBCONTRACTOR FAILS TO PAY SUBCONTRACTORS, SUB-SUBCONTRACTORS, OR MATERIAL SUPPLIERS, THOSE PEOPLE WHO ARE OWED MONEY MAY LOOK TO YOUR PROPERTY FOR PAYMENT, EVEN IF YOU HAVE ALREADY PAID YOUR CONTRACTOR IN FULL. IF YOU FAIL TO PAY YOUR CONTRACTOR, YOUR CONTRACTOR MAY ALSO HAVE A LIEN ON YOUR PROPERTY. THIS MEANS IF A LIEN IS FILED YOUR PROPERTY COULD BE SOLD AGAINST YOUR WILL TO PAY FOR LABOR, MATERIALS, OR OTHER SERVICES THAT YOUR CONTRACTOR OR A SUBCONTRACTOR MAY HAVE FAILED TO PAY. TO PROTECT YOURSELF, YOU SHOULD STIPULATE IN THIS CONTRACT THAT BEFORE ANY PAYMENT IS MADE, YOUR CONTRACTOR IS REQUIRED TO PROVIDE YOU WITH A WRITTEN RELEASE OF LIEN FROM ANY PERSON OR COMPANY THAT HAS PROVIDED TO YOU A "NOTICE TO OWNER." FLORIDA'S CONSTRUCTION LIEN LAW IS COMPLEX, AND IT IS RECOMMENDED THAT YOU CONSULT AN ATTORNEY.

Signature _____ **Date** _____

Walls/Ceilings

- We are happy to move Furniture, TV's, window blinds and other items, but are not at fault if items are damaged during the process
- We protect floors, cabinets and misc items with plastic and canvas if needed
- We use low tack painters tape. Any damage caused to trim, wall and other client's items are not the responsibility of M&A Pro Painting.
- Minor defects in the walls and ceilings are patched and sanded
- We warranty all drywall work for 7 days from completion of the specific repair - we cannot stop houses from moving and causing the cracks to reappear
- We can do major drywall repair for \$75/hr plus materials
- We patch all nail and screw holes unless a nail/screw remains in the wall at the time of painting
- Unless otherwise specified, a durable Flat/Matte finish will be used on the walls and flat white on the ceilings
- We will utilize a combination of brush, roll and spray methods to apply coatings
- Unless otherwise specified, 2 topcoats will be applied to your walls and 1 coat to the ceilings
- If a 3rd coat is needed because of shine/drastric color change +35% charge will be added

Cabinets/Trim

- On average: kitchen cabinets 5-7 working days - Main Floor Trim 2-3 weeks - varies based on complexity and scope
- Cabinets must be fully emptied prior to the start of your project. We will remove items for \$75/hr.
- We will move appliances, but are not responsible for damage or water leaks from water lines that occurs during the process
- We will move washers and dryers out just far enough to paint around. We do not disconnect wires, vents or water lines.
- We paint around stoves, but move refrigerators out of their openings to paint
- Low tack painters tape and paper will be used to protect all floors, trim and cabinets. Damage to these surfaces from low tack painters tape is a sign of a failed finish and is not the liability of M&A Pro Painting
- All alterations to the kitchen must be made prior to the start of the project - especially changing of hardware (pulls and hinges, countertops)
- Doors/Drawers and hardware will be removed and prepped, primed and finished in our shop/finishing facility
- Wood will be sanded, vacuumed and dust will be removed with microfiber cloths
- Nail holes will be filled if needed. Cracks will be caulked.
- We do not caulk the floating panels on cabinet doors-they are meant to move seasonally
- Oak grain will be minimized by our processes, but not completely leveled and removed and will resemble sample cabinet door/images shown to client
- Walls will need to be painted after enameling. If walls are to be left unpainted, we charge \$75/hr to mask off - touch ups will be needed after
- Cabinets and trim will be primed once and top coated twice with enamel unless otherwise noted
- We will utilize a combination of hand-finishing, spray-finishing and roller application methods to apply coatings to your home
- Unless specified, no cabinet interiors will be painted.
- Cabinet doors may need to be adjusted by a carpenter/cabinet maker after completion - we charge \$90/hr for this service

General Notes

Interior Painting – Informational Signoff



- Supply Chain Interruptions: We use will equivalent quality coatings; that we have vetted; on your project should a coating be unavailable.
- We will place one crew on your project (1-4 Craftspeople). If Crew leaders are absent, we will pause your project and resume when the crew leader returns (illness, family matters, school functions, etc)
- Garbage disposal is the responsibility of the client. M&A Pro Painting will dispose of job site garbage for \$100 (unless a dumpster is agreed upon and ordered)
- All work requested to be performed by client after start of project (not estimated) will be charged at \$75/hr per person + materials (Time & Materials)
- Carpentry: we will be happy to help you with carpentry and handyman projects - \$90/hr + materials (Time & Materials)
- It is the responsibility of the client to safeguard their gas and electric appliances/utilities while work is occurring (i.e. water heater, furnace)
- Color: we can connect you with one of our interior designers. Cost for a formal color consult varies based on designer
- In order to determine whether a surface has been properly painted it shall be examined without magnification at a distance of 4 feet or more under normal finished lighting conditions (no use of handheld light source) and from a normal viewing position.

Our Promise To You:

We Put Up Color Samples – We Clean – We Move Furniture

I have read, understand and agree to this information: _____

Name

Sign

Date

ENROLLED

HB 735

2021 Legislature

1
2 An act relating to preemption of local occupational
3 licensing; creating s. 163.211, F.S.; providing
4 definitions; preempting licensing of occupations to
5 the state; providing exceptions; prohibiting local
6 governments from imposing additional licensing
7 requirements or modifying licensing unless specified
8 conditions are met; specifying that certain local
9 licensing that does not meet specified criteria does
10 not apply and may not be enforced; amending s.
11 489.117, F.S.; specifying that certain specialty
12 contractors are not required to register with the
13 Construction Industry Licensing Board; prohibiting
14 local governments from requiring certain specialty
15 contractors to obtain a license under specified
16 circumstances; specifying job scopes for which a local
17 government may not require a license; amending ss.
18 489.1455 and 489.5335, F.S.; authorizing counties and
19 municipalities to issue certain journeyman licenses;
20 providing an effective date.

21
22 Be It Enacted by the Legislature of the State of Florida:

23
24 Section 1. Section 163.211, Florida Statutes, is created
25 to read:

ENROLLED

HB 735

2021 Legislature

26 163.211 Licensing of occupations preempted to state.-

27 (1) DEFINITIONS.-As used in this section:

28 (a) "Licensing" means any training, education, test,
29 certification, registration, or license that is required for a
30 person to perform an occupation in addition to any associated
31 fee.

32 (b) "Local government" means a county, municipality,
33 special district, or political subdivision of the state.

34 (c) "Occupation" means a paid job, profession, work, line
35 of work, trade, employment, position, post, career, field,
36 vocation, or craft.

37 (2) PREEMPTION OF OCCUPATIONAL LICENSING TO THE STATE.-The
38 licensing of occupations is expressly preempted to the state and
39 this section supersedes any local government licensing
40 requirement of occupations with the exception of the following:

41 (a) Any local government that imposed licenses on
42 occupations before January 1, 2021. However, any such local
43 government licensing of occupations expires on July 1, 2023.

44 (b) Any local government licensing of occupations
45 authorized by general law.

46 (3) EXISTING LICENSING LIMIT.-A local government that
47 licenses occupations and retains such licensing as set forth in
48 paragraph (2)(a) may not impose additional licensing
49 requirements on that occupation or modify such licensing.

50 (4) LOCAL LICENSING NOT AUTHORIZED.-Local licensing of an

ENROLLED

HB 735

2021 Legislature

51 occupation that is not authorized under this section or
52 otherwise authorized by general law does not apply and may not
53 be enforced.

54 Section 2. Paragraph (a) of subsection (4) of section
55 489.117, Florida Statutes, is amended to read:

56 489.117 Registration; specialty contractors.—

57 (4) (a) A person ~~holding a local license~~ whose job scope
58 does not substantially correspond to either the job scope of one
59 of the contractor categories defined in s. 489.105(3)(a)-(o), or
60 the job scope of one of the certified specialty contractor
61 categories established by board rule, is not required to
62 register with the board ~~to perform contracting activities within~~
63 ~~the scope of such specialty license.~~ A local government, as
64 defined in s. 163.211, may not require a person to obtain a
65 license for a job scope which does not substantially correspond
66 to the job scope of one of the contractor categories defined in
67 s. 489.105(3)(a)-(o) and (q) or authorized in s. 489.1455(1).
68 For purposes of this section, job scopes for which a local
69 government may not require a license include, but are not
70 limited to, painting; flooring; cabinetry; interior remodeling;
71 driveway or tennis court installation; handyman services;
72 decorative stone, tile, marble, granite, or terrazzo
73 installation; plastering; stuccoing; caulking; and canvas awning
74 and ornamental iron installation.

75 Section 3. Section 489.1455, Florida Statutes, is amended

ENROLLED

HB 735

2021 Legislature

76 to read:

77 489.1455 Journeyman; reciprocity; standards.—

78 (1) Counties and municipalities are authorized to issue
 79 journeyman licenses in the plumbing, pipe fitting, mechanical,
 80 or HVAC trades.

81 (2)~~(1)~~ An individual who holds a valid, active journeyman
 82 license in the plumbing, pipe fitting ~~plumbing/pipe fitting,~~
 83 mechanical, or HVAC trades issued by any county or municipality
 84 in this state may work as a journeyman in the trade in which he
 85 or she is licensed in any county or municipality of this state
 86 without taking an additional examination or paying an additional
 87 license fee, if he or she:

88 (a) Has scored at least 70 percent, or after October 1,
 89 1997, at least 75 percent, on a proctored journeyman Block and
 90 Associates examination or other proctored examination approved
 91 by the board for the trade in which he or she is licensed;

92 (b) Has completed an apprenticeship program registered
 93 with a registration agency defined in 29 C.F.R. s. 29.2 and
 94 demonstrates 4 years' verifiable practical experience in the
 95 trade for which he or she is licensed, or demonstrates 6 years'
 96 verifiable practical experience in the trade for which he or she
 97 is licensed;

98 (c) Has satisfactorily completed specialized and advanced
 99 module coursework approved by the Florida Building Commission,
 100 as part of the building code training program established in s.

ENROLLED

HB 735

2021 Legislature

101 553.841, specific to the discipline or, pursuant to
 102 authorization by the certifying authority, provides proof of
 103 completion of such coursework within 6 months after such
 104 certification; and

105 (d) Has not had a license suspended or revoked within the
 106 last 5 years.

107 ~~(3)(2)~~ A local government may charge a registration fee
 108 for reciprocity, not to exceed \$25.

109 Section 4. Section 489.5335, Florida Statutes, is amended
 110 to read:

111 489.5335 Journeyman; reciprocity; standards.—

112 (1) Counties and municipalities are authorized to issue
 113 journeyman licenses in the electrical and alarm system trades.

114 ~~(2)(1)~~ An individual who holds a valid, active journeyman
 115 license in the electrical or alarm system trade issued by any
 116 county or municipality in this state may work as a journeyman in
 117 the trade in which he or she is licensed in any other county or
 118 municipality of this state without taking an additional
 119 examination or paying an additional license fee, if he or she:

120 (a) Has scored at least 70 percent, or after October 1,
 121 1997, at least 75 percent, on a proctored journeyman Block and
 122 Associates examination or other proctored examination approved
 123 by the board for the ~~electrical~~ trade in which he or she is
 124 licensed;

125 (b) Has completed an apprenticeship program registered

ENROLLED

HB 735

2021 Legislature

126 with a registration agency defined in 29 C.F.R. s. 29.2 and
 127 demonstrates 4 years' verifiable practical experience in the
 128 ~~electrical~~ trade for which he or she is licensed, or
 129 demonstrates 6 years' verifiable practical experience in the
 130 ~~electrical~~ trade for which he or she is licensed;

131 (c) Has satisfactorily completed specialized and advanced
 132 module coursework approved by the Florida Building Commission,
 133 as part of the building code training program established in s.
 134 553.841, specific to the discipline, or, pursuant to
 135 authorization by the certifying authority, provides proof of
 136 completion of such curriculum or coursework within 6 months
 137 after such certification; and

138 (d) Has not had a license suspended or revoked within the
 139 last 5 years.

140 (3) ~~(2)~~ A local government may charge a registration fee
 141 for reciprocity, not to exceed \$25.

142 Section 5. This act shall take effect July 1, 2021.



CERTIFICATE OF LIABILITY INSURANCE

DATE (MM/DD/YYYY)

04/23/2024

THIS CERTIFICATE IS ISSUED AS A MATTER OF INFORMATION ONLY AND CONFERS NO RIGHTS UPON THE CERTIFICATE HOLDER. THIS CERTIFICATE DOES NOT AFFIRMATIVELY OR NEGATIVELY AMEND, EXTEND OR ALTER THE COVERAGE AFFORDED BY THE POLICIES BELOW. THIS CERTIFICATE OF INSURANCE DOES NOT CONSTITUTE A CONTRACT BETWEEN THE ISSUING INSURER(S), AUTHORIZED REPRESENTATIVE OR PRODUCER, AND THE CERTIFICATE HOLDER.

IMPORTANT: If the certificate holder is an ADDITIONAL INSURED, the policy(ies) must have ADDITIONAL INSURED provisions or be endorsed. If SUBROGATION IS WAIVED, subject to the terms and conditions of the policy, certain policies may require an endorsement. A statement on this certificate does not confer rights to the certificate holder in lieu of such endorsement(s).

PRODUCER 1st Allegiant Insurance, LLC 12555 Orange Dr Ste. 245 Davie FL 33330	CONTACT NAME: Lina Pinilla PHONE (A/C, No, Ext): (954) 378-3235 E-MAIL ADDRESS: support@1stalliegiant.com	FAX (A/C, No): (954) 323-5477
	INSURER(S) AFFORDING COVERAGE	
INSURED M&A Professional Painting 1119 N 46th Ter Hollywood FL 33021	INSURER A: Evanston Insurance Company NAIC # 35378	
	INSURER B:	
	INSURER C:	
	INSURER D:	
	INSURER E:	
	INSURER F:	

COVERAGES **CERTIFICATE NUMBER:** Blanket 2 cov Certificate **REVISION NUMBER:**

THIS IS TO CERTIFY THAT THE POLICIES OF INSURANCE LISTED BELOW HAVE BEEN ISSUED TO THE INSURED NAMED ABOVE FOR THE POLICY PERIOD INDICATED. NOTWITHSTANDING ANY REQUIREMENT, TERM OR CONDITION OF ANY CONTRACT OR OTHER DOCUMENT WITH RESPECT TO WHICH THIS CERTIFICATE MAY BE ISSUED OR MAY PERTAIN, THE INSURANCE AFFORDED BY THE POLICIES DESCRIBED HEREIN IS SUBJECT TO ALL THE TERMS, EXCLUSIONS AND CONDITIONS OF SUCH POLICIES. LIMITS SHOWN MAY HAVE BEEN REDUCED BY PAID CLAIMS.

INSR LTR	TYPE OF INSURANCE	ADDL INSD	SUBR WVD	POLICY NUMBER	POLICY EFF (MM/DD/YYYY)	POLICY EXP (MM/DD/YYYY)	LIMITS
A	<input checked="" type="checkbox"/> COMMERCIAL GENERAL LIABILITY <input type="checkbox"/> CLAIMS-MADE <input checked="" type="checkbox"/> OCCUR GEN'L AGGREGATE LIMIT APPLIES PER: <input type="checkbox"/> POLICY <input type="checkbox"/> PRO-JECT <input type="checkbox"/> LOC OTHER:	Y		3AA724443	11/01/2023	11/01/2024	EACH OCCURRENCE \$ 1,000,000
	DAMAGE TO RENTED PREMISES (Ea occurrence) \$ 100,000 MED EXP (Any one person) \$ 5,000 PERSONAL & ADV INJURY \$ 1,000,000 GENERAL AGGREGATE \$ 2,000,000 PRODUCTS - COMP/OP AGG \$ 2,000,000 Employee Benefits \$						
	AUTOMOBILE LIABILITY <input type="checkbox"/> ANY AUTO <input type="checkbox"/> OWNED AUTOS ONLY <input type="checkbox"/> SCHEDULED AUTOS <input type="checkbox"/> HIRED AUTOS ONLY <input type="checkbox"/> NON-OWNED AUTOS ONLY						COMBINED SINGLE LIMIT (Ea accident) \$ BODILY INJURY (Per person) \$ BODILY INJURY (Per accident) \$ PROPERTY DAMAGE (Per accident) \$
	<input type="checkbox"/> UMBRELLA LIAB <input type="checkbox"/> OCCUR <input type="checkbox"/> EXCESS LIAB <input type="checkbox"/> CLAIMS-MADE DED RETENTION \$						EACH OCCURRENCE \$ AGGREGATE \$
	WORKERS COMPENSATION AND EMPLOYERS' LIABILITY ANY PROPRIETOR/PARTNER/EXECUTIVE OFFICER/MEMBER EXCLUDED? (Mandatory in NH) <input type="checkbox"/> Y/N If yes, describe under DESCRIPTION OF OPERATIONS below		N/A				PER STATUTE OTH-ER E.L. EACH ACCIDENT \$ E.L. DISEASE - EA EMPLOYEE \$ E.L. DISEASE - POLICY LIMIT \$

DESCRIPTION OF OPERATIONS / LOCATIONS / VEHICLES (ACORD 101, Additional Remarks Schedule, may be attached if more space is required)

Certificate holder is an additional insured for general liability when required by written contract.

CERTIFICATE HOLDER OXFORD TOWERS 1501 S OCEAN DRIVE HOLLYWOOD FL 33019	CANCELLATION SHOULD ANY OF THE ABOVE DESCRIBED POLICIES BE CANCELLED BEFORE THE EXPIRATION DATE THEREOF, NOTICE WILL BE DELIVERED IN ACCORDANCE WITH THE POLICY PROVISIONS.
	AUTHORIZED REPRESENTATIVE 

© 1988-2015 ACORD CORPORATION. All rights reserved.

MARVELOUS PAINTING LLC

351 Cambridge Rd, #114, Hollywood, FL 33024

Marvelouspaintingllc@gmail.com

Telephone: (786) 320-3993

Date: April 20, 2024
To: American Management (Phone #: 786-410-6727)
Email: manager@americanmgmtgroup.com; campropmgr2@outlook.com
info@americanmgmtgroup.com; Csr@americanmgmtgroup.com;
Location: Oxford Towers, 1501 S. Ocean Dr., Hollywood, FL 33019

PROPOSAL

The following work is to be performed at the address mentioned above. Cover holes on the walls, as needed. Paint the walls and ceilings with Sherwin Williams Super Paint (paint and primer in one) in the following areas:

Lobby	\$400.00
Mail Room	\$200.00
Rec Room	\$800.00
Hallway (1 st Floor)	\$1,400.00
Hallways (2 nd – 16 th Floor)	\$1,600.00 x 15 = \$24,000.00

All paint, labor and materials are included in the amount of \$26,800.00.
Please be advised that this estimate does not include the fire escape staircases.

This is a proposal, not a contract unless signed by vendor and client.

Vendor: _____

Client: _____

Date: _____

PAINTING INTERIOR AND EXTERIOR

21-P-21262-X

MATUTE, MARLIN E. - QUALIFYING

MARVELOUS PAINTING LLC

351 CAMBRIDGE ROAD SUITE 114

HOLLYWOOD FL 33024

EXPIRES 06/30/2024



CERTIFICATE OF COMPETENCY

Detach and SIGN the reverse side of this card IMMEDIATELY upon receipt! You should carry this card with you at all times.

Contractor must obtain a photo I.D. Certificate of Competency Card every two years.

MATUTE, MARLIN E.
351 CAMBRIDGE ROAD SUITE 114
HOLLYWOOD FL 33024

**BROWARD COUNTY, FLORIDA
CERTIFICATE OF COMPETENCY**

CC# PAINTING INTERIOR AND EXTERIOR
21-P-21262-X
MATUTE, MARLIN E. - QUALIFYING
MARVELOUS PAINTING LLC
351 CAMBRIDGE ROAD SUITE 114
HOLLYWOOD FL 33024
EXPIRES 06/30/2024



CERTIFICATE OF LIABILITY INSURANCE

DATE (MM/DD/YYYY)

1/31/2024

THIS CERTIFICATE IS ISSUED AS A MATTER OF INFORMATION ONLY AND CONFERS NO RIGHTS UPON THE CERTIFICATE HOLDER. THIS CERTIFICATE DOES NOT AFFIRMATIVELY OR NEGATIVELY AMEND, EXTEND OR ALTER THE COVERAGE AFFORDED BY THE POLICIES BELOW. THIS CERTIFICATE OF INSURANCE DOES NOT CONSTITUTE A CONTRACT BETWEEN THE ISSUING INSURER(S), AUTHORIZED REPRESENTATIVE OR PRODUCER, AND THE CERTIFICATE HOLDER.

IMPORTANT: If the certificate holder is an ADDITIONAL INSURED, the policy(ies) must be endorsed. If SUBROGATION IS WAIVED, subject to the terms and conditions of the policy, certain policies may require an endorsement. A statement on this certificate does not confer rights to the certificate holder in lieu of such endorsement(s).

PRODUCER Business Express Insurance Agency 225 E Dania Beach Blvd Suite 120 Dania Beach FL 33004	CONTACT NAME: Certificate Department PHONE (A/C, No, Ext): 800-677-2905 E-MAIL ADDRESS: certs@beagency.com	FAX (A/C, No): 954-697-4570
	INSURER(S) AFFORDING COVERAGE	
	INSURER A : Service Lloyds Insurance Company	NAIC # 43389
INSURED MARVELOUS PAINTING, LLC 351 Cambridge Rd. #114 Hollywood FL 33024	INSURER B :	
	INSURER C :	
	INSURER D :	
	INSURER E :	
	INSURER F :	

COVERAGES **CERTIFICATE NUMBER:** **REVISION NUMBER:**

THIS IS TO CERTIFY THAT THE POLICIES OF INSURANCE LISTED BELOW HAVE BEEN ISSUED TO THE INSURED NAMED ABOVE FOR THE POLICY PERIOD INDICATED. NOTWITHSTANDING ANY REQUIREMENT, TERM OR CONDITION OF ANY CONTRACT OR OTHER DOCUMENT WITH RESPECT TO WHICH THIS CERTIFICATE MAY BE ISSUED OR MAY PERTAIN, THE INSURANCE AFFORDED BY THE POLICIES DESCRIBED HEREIN IS SUBJECT TO ALL THE TERMS, EXCLUSIONS AND CONDITIONS OF SUCH POLICIES. LIMITS SHOWN MAY HAVE BEEN REDUCED BY PAID CLAIMS.

INSR LTR	TYPE OF INSURANCE	ADDL INSD	SUBR WVD	POLICY NUMBER	POLICY EFF (MM/DD/YYYY)	POLICY EXP (MM/DD/YYYY)	LIMITS	
	COMMERCIAL GENERAL LIABILITY <input type="checkbox"/> CLAIMS-MADE <input type="checkbox"/> OCCUR GEN'L AGGREGATE LIMIT APPLIES PER: <input type="checkbox"/> POLICY <input type="checkbox"/> PRO-JECT <input type="checkbox"/> LOC OTHER:						EACH OCCURRENCE	\$
	AUTOMOBILE LIABILITY <input type="checkbox"/> ANY AUTO <input type="checkbox"/> ALL OWNED AUTOS <input type="checkbox"/> HIRED AUTOS <input type="checkbox"/> SCHEDULED AUTOS <input type="checkbox"/> NON-OWNED AUTOS						COMBINED SINGLE LIMIT (Ea accident)	\$
	UMBRELLA LIAB <input type="checkbox"/> OCCUR EXCESS LIAB <input type="checkbox"/> CLAIMS-MADE DED RETENTION \$						EACH OCCURRENCE	\$
	WORKERS COMPENSATION AND EMPLOYERS' LIABILITY ANY PROPRIETOR/PARTNER/EXECUTIVE OFFICER/MEMBER EXCLUDED? (Mandatory in NH) If yes, describe under DESCRIPTION OF OPERATIONS below	Y/N	N/A	Y	13006	1/26/2024	1/26/2025	<input checked="" type="checkbox"/> PER STATUTE <input type="checkbox"/> OTH-ER E.L. EACH ACCIDENT \$ 1,000,000 E.L. DISEASE - EA EMPLOYEE \$ 1,000,000 E.L. DISEASE - POLICY LIMIT \$ 1,000,000

DESCRIPTION OF OPERATIONS / LOCATIONS / VEHICLES (ACORD 101, Additional Remarks Schedule, may be attached if more space is required)

See policy for terms, conditions and exclusions.

CERTIFICATE HOLDER**CANCELLATION**

PROOF OF COVERAGE

SHOULD ANY OF THE ABOVE DESCRIBED POLICIES BE CANCELLED BEFORE THE EXPIRATION DATE THEREOF, NOTICE WILL BE DELIVERED IN ACCORDANCE WITH THE POLICY PROVISIONS.

AUTHORIZED REPRESENTATIVE

Kaytissa Mackey

© 1988-2014 ACORD CORPORATION. All rights reserved.



CERTIFICATE OF LIABILITY INSURANCE

DATE (MM/DD/YYYY)
10/16/2023

THIS CERTIFICATE IS ISSUED AS A MATTER OF INFORMATION ONLY AND CONFERS NO RIGHTS UPON THE CERTIFICATE HOLDER. THIS CERTIFICATE DOES NOT AFFIRMATIVELY OR NEGATIVELY AMEND, EXTEND OR ALTER THE COVERAGE AFFORDED BY THE POLICIES BELOW. THIS CERTIFICATE OF INSURANCE DOES NOT CONSTITUTE A CONTRACT BETWEEN THE ISSUING INSURER(S), AUTHORIZED REPRESENTATIVE OR PRODUCER, AND THE CERTIFICATE HOLDER.

IMPORTANT: If the certificate holder is an ADDITIONAL INSURED, the policy(ies) must have ADDITIONAL INSURED provisions or be endorsed. If SUBROGATION IS WAIVED, subject to the terms and conditions of the policy, certain policies may require an endorsement. A statement on this certificate does not confer rights to the certificate holder in lieu of such endorsement(s).

PRODUCER Hiscox Inc. 5 Concourse Parkway Suite 2150 Atlanta GA, 30328	CONTACT NAME: PHONE (A/C, No, Ext): (888) 202-3007 FAX (A/C, No): E-MAIL ADDRESS: contact@hiscox.com	
	INSURER(S) AFFORDING COVERAGE NAIC # INSURER A : Hiscox Insurance Company Inc 10200 INSURER B : INSURER C : INSURER D : INSURER E : INSURER F :	
INSURED MARVELOUS PAINTING, LLC 351 Cambridge Rd APT 114 Hollywood, FL 33024		

COVERAGES **CERTIFICATE NUMBER:** **REVISION NUMBER:**

THIS IS TO CERTIFY THAT THE POLICIES OF INSURANCE LISTED BELOW HAVE BEEN ISSUED TO THE INSURED NAMED ABOVE FOR THE POLICY PERIOD INDICATED. NOTWITHSTANDING ANY REQUIREMENT, TERM OR CONDITION OF ANY CONTRACT OR OTHER DOCUMENT WITH RESPECT TO WHICH THIS CERTIFICATE MAY BE ISSUED OR MAY PERTAIN, THE INSURANCE AFFORDED BY THE POLICIES DESCRIBED HEREIN IS SUBJECT TO ALL THE TERMS, EXCLUSIONS AND CONDITIONS OF SUCH POLICIES. LIMITS SHOWN MAY HAVE BEEN REDUCED BY PAID CLAIMS.

INSR LTR	TYPE OF INSURANCE	ADDL INSD	SUBR WVD	POLICY NUMBER	POLICY EFF (MM/DD/YYYY)	POLICY EXP (MM/DD/YYYY)	LIMITS	
A	<input checked="" type="checkbox"/> COMMERCIAL GENERAL LIABILITY <input type="checkbox"/> CLAIMS-MADE <input checked="" type="checkbox"/> OCCUR GEN'L AGGREGATE LIMIT APPLIES PER: <input checked="" type="checkbox"/> POLICY <input type="checkbox"/> PRO-JECT <input type="checkbox"/> LOC OTHER:			P102.086.501.2	11/30/2023	11/30/2024	EACH OCCURRENCE	\$ 1,000,000
							DAMAGE TO RENTED PREMISES (Ea occurrence)	\$ 100,000
							MED EXP (Any one person)	\$ 5,000
							PERSONAL & ADV INJURY	\$ 1,000,000
							GENERAL AGGREGATE	\$ 1,000,000
							PRODUCTS - COMP/OP AGG	\$ 1,000,000
								\$
	AUTOMOBILE LIABILITY <input type="checkbox"/> ANY AUTO <input type="checkbox"/> ALL OWNED AUTOS <input type="checkbox"/> HIRED AUTOS <input type="checkbox"/> SCHEDULED AUTOS <input type="checkbox"/> NON-OWNED AUTOS						COMBINED SINGLE LIMIT (Ea accident)	\$
							BODILY INJURY (Per person)	\$
							BODILY INJURY (Per accident)	\$
							PROPERTY DAMAGE (Per accident)	\$
								\$
	<input type="checkbox"/> UMBRELLA LIAB <input type="checkbox"/> OCCUR <input type="checkbox"/> EXCESS LIAB <input type="checkbox"/> CLAIMS-MADE <input type="checkbox"/> DED <input type="checkbox"/> RETENTION \$						EACH OCCURRENCE	\$
							AGGREGATE	\$
								\$
	WORKERS COMPENSATION AND EMPLOYERS' LIABILITY ANY PROPRIETOR/PARTNER/EXECUTIVE OFFICER/MEMBER EXCLUDED? (Mandatory in NH) If yes, describe under DESCRIPTION OF OPERATIONS below						PER STATUTE	OTH-ER
							E.L. EACH ACCIDENT	\$
							E.L. DISEASE - EA EMPLOYEE	\$
							E.L. DISEASE - POLICY LIMIT	\$

DESCRIPTION OF OPERATIONS / LOCATIONS / VEHICLES (ACORD 101, Additional Remarks Schedule, may be attached if more space is required)

CERTIFICATE HOLDER 	CANCELLATION SHOULD ANY OF THE ABOVE DESCRIBED POLICIES BE CANCELLED BEFORE THE EXPIRATION DATE THEREOF, NOTICE WILL BE DELIVERED IN ACCORDANCE WITH THE POLICY PROVISIONS.
	AUTHORIZED REPRESENTATIVE 