



QUOTATION

Prepared For:
The Pete Store
City of Hollywood

Ship To:
Florida Truck Dealer

Prepared By:
Sunbelt Waste Equipment.

FSA2023

4/25/2023

QUOTE REFERENCE NUMBER	ISSUE DATE	VALID FOR	EST. DELIVERY FROM RECEIPT OF ORDER	SUBMITTED BY	SHIPPED VIA	FOB POINT	TERMS
MC42523	4/25/2023	1 Year	TBD at Time of Order	Heil Dealers	Drive Away	Dealer	Net 30 Days

Body

Heil PT-1000-16 Yard Single Axle Rear Loader

Standard Options

PTO & Pump

- Body Back Up Assist Light
- Hopper Work Light
- 20 Lb. Fire Extinguisher
- Single Camera System
- All Standard Features
- 12 Month Warranty
- LED Light Package
- Freight from Ft. Payne

FSA2023 Body \$94,188.00

Non Standard Options

- Bayne BTL110 Cart Tipper Dual (2) \$15,356.00
- Dual Outside Hopper Work Light \$ 670.00
- 12,000lb Winch \$ 7,198.00
- Lip and Latch \$ 2,025.00

Total Body and All Above Options \$ 119,437.00

Chassis must be at Heil By September 1 2023 to hold FSA2023 Pricing*

THANK YOU FOR THE OPPORTUNITY TO QUOTE!

If you have any questions concerning this quotation, please feel free to contact us.

Sunbelt Waste Equipment
2201 N.W. 22nd St.
Pompano Beach, FL 33069
561-274-8505
954-444-1529 Cell



QUOTATION

Prepared For:

The Pete Store
City of Hollywood

FSA2023

Ship To:

Florida Truck Dealer

Prepared By:

Sunbelt Waste Equipment.

4/25/2023

QUOTE REFERENCE NUMBER	ISSUE DATE	VALID FOR	EST. DELIVERY FROM RECEIPT OF ORDER	SUBMITTED BY	SHIPPED VIA	FOB POINT	TERMS
MC42523	4/25/2023	1 Year	TBD at Time of Order	Heil Dealers	Drive Away	Dealer	Net 30 Days

Body

Heil PT-1000-16 Yard Single Axle Rear Loader

Standard Options

PTO & Pump

Body Back Up Assist Light
Hopper Work Light
20 Lb. Fire Extinguisher
Single Camera System
All Standard Features
12 Month Warranty
LED Light Package
Freight from Ft. Payne

Non Standard Options

Bayne BTL110 Cart Tipper Dual (2)
Dual Outside Hopper Work Light
12,000lb Winch
Lip and Latch

Total Body and All Above Options

Chassis must be at Heil By September 1 2023 to hold FSA2023 Pricing*

THANK YOU FOR THE OPPORTUNITY TO QUOTE!

If you have any questions concerning this quotation, please feel free to contact us.

Sunbelt Waste Equipment
2201 N.W. 22nd St.
Pompano Beach, FL 33069
561-274-8505
954-444-1529 Cell

CHASSIS ELECTRICAL REQUIREMENTS:
SEE SHEET 2

CHASSIS LAYOUT REQUIREMENTS
PT 1000 SINGLE AXLE UNITS



THE WHEELS ARE ALWAYS TURNING

ABBREVIATIONS

- "WB" = WHEELBASE
- "CA" = USABLE CAB-AXLE
- "PF" = PLATFORM
- "AF" = AFTERFRAME
- "CG" = CENTER OF GRAVITY (BODY & LOAD)
- "C.O.E." = CAB OVER ENGINE
- "CONV. CAB" = CONVENTIONAL CAB
- "ER" = ENGINEERING REQUIRED

121

BODY SIZE	13 YD	16 YD	18 YD	20 YD
CA (USABLE)	96	102-110	117-125	132-140
C.O.E. WB (TYPICAL)		127-135	142-150	157-165
CONV. CAB WB (TYPICAL)	161	167-175	182-190	197-205
AF (MIN)	51	51	51	51
LENGTH @ BODY FLOOR	115	130	145	162
PF (MIN)	147	153-161	168-176	183-191
PAYLOAD "CG"	83	87	95	100
BODY "CG"	94	105	113	120
MOUNTED BODY WEIGHT	10,350	10,800	11,100	11,400
TYPICAL PAYLOAD	13,000	16,000	18,000	20,000
PUSHER CAPABLE	ER	ER	ER	ER

MEASUREMENTS ARE IN INCHES. WEIGHTS ARE IN LBS.

- NOTES:
- 1) THIS AREA FOR THE BODY VALVE. ANY COMPONENT IN THIS AREA MUST BE LOWERED 6" BELOW TOP OF RAIL.
 - 2) THIS AREA MUST BE CLEAR IN THIS RANGE FOR THE OIL TANK
 - 3) MOUNTED BODY WEIGHT DOES NOT INCLUDE OPTIONAL EQUIPMENT
 - 4) -
 - 5) THIS AREA FOR PTO CLEARANCE
 - 6) THIS AREA FOR SUCTION LINE CLEARANCE
 - 7) IF ORDERING A FRONT HEAD MOUNTED HYDRAULIC OIL TANK, ADD 15" TO CA & PF.
 - 8) AIR TANKS MUST BE LOCATED INSIDE CHASSIS FRAME RAILS AND ABOVE THE DRIVE LINE.
 - 9) ALL HORIZONTAL EXHAUST COMPONENTS MUST BE LOCATED INSIDE FRAME RAILS.
 - 10) THIS AREA FOR BATTERY BOX IF BATTERIES WILL NOT FIT IN SPACE AVAILABLE THEY MUST BE MOUNTED ON RIGHT HAND CHASSIS RAIL.
 - 11) FRONT MOUNT PUMPS REQUIRE A MINIMUM 4-7/8" BUMPER EXTENSION.
 - 12) TELMA INSTALL MUST BE PRE-EVALUATE BY HEIL ENGINEERING BEFORE CHASSIS IS ORDERED.

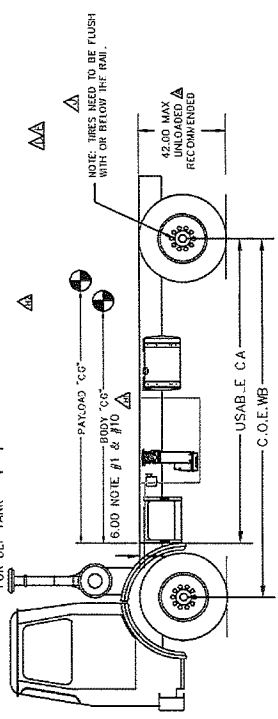
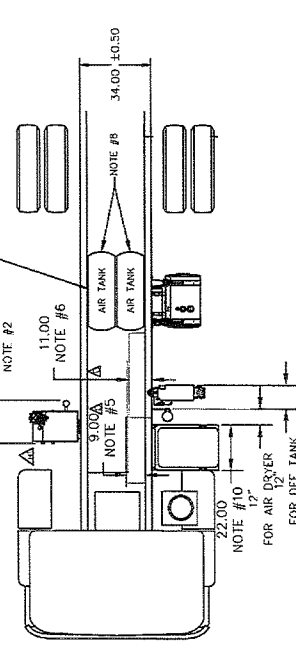
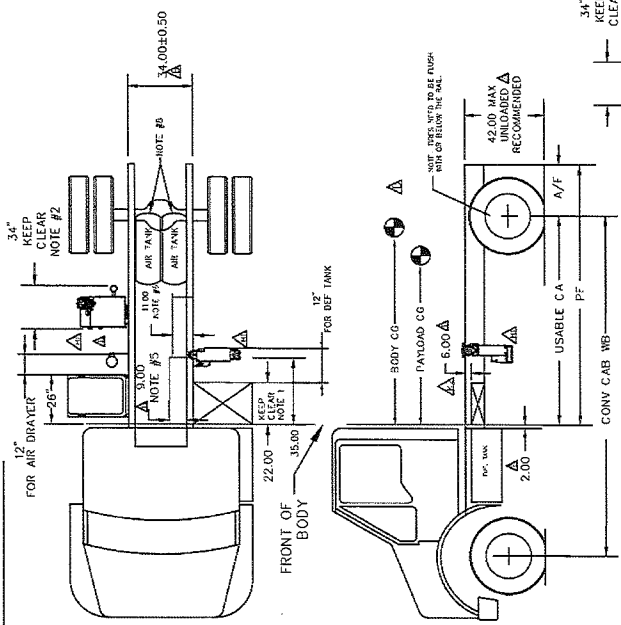

REV	DATE	ECO No.	DESCRIPTION
K2	19-02-21	DPF21018	DIRV 6.00 WAS DIM 2.00
K1	19-02-21	DPF21018	NOTES UPDATED
J	08-08-18	DPF19053	NOTES UPDATED
H3	10-08-18	DPF18128	ELECTRICAL TABLE UPDATED (SHEET-02)
H2	10-08-18	DPF18128	NOTES & VIEWS UPDATED
H1	10-08-18	DPF18128	ADDED BATTERY BOX, AIR TANK, AIR DRIVER & DEF TANK

REV	DATE	ECO No.	DESCRIPTION
G	01-06-14	DPF13106	UPDATED 20YD TABLE VALUES
F	03-15-13	PT13007	ADDED NOTE #8
E	02-20-13	PT13006	ADDED 13YD, 16YD MODIFIED TIRE NOTE TO ALLOW 2.5" ABOVE VERSES 0" ABOVE.
D	7-31-12	5F12024	ADDED NOTE'S #6, #7, & TIRE NOTE. ADDED 4" CLEARANCE SPECIFICATION TO SHEET 2. CHASSIS SPACE WEIGHTS MODIFIED NOTE #8, ADDED TIRE LIGHT. ADDED NOTE #10.
C	04-03-12	DPF12042	ADDED NOTE 5
B	03-18-11	DPF11038	ADDED C-AXIS WIDTH DIMENSION 34.00 ±0.50
A	12-2-10	DPF10142	NOTE 9 ADDED IN ELECTRICAL NOTE. DIM 47 ADDED. EXHAUST DETAILS TABLE ADDED.

CONVENTIONAL CHASSIS	EXHAUST AND DIESEL PARTICULATE FILTER
RIGHT HAND DRIVE	HORIZONTAL, DPF
LEFT HAND DRIVE	
RIGHT HAND DRIVE	

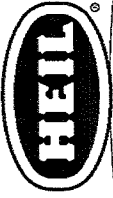

THE WHEELS ARE ALWAYS TURNING

CHASSIS LAYOUT REQUIREMENTS
PT 1000 SINGLE AXLE UNITS

CHASSIS ELECTRICAL REQUIREMENTS:

- 1) NEUTRAL SIGNAL DEDICATED FOR BODY BUILDER USE-IN CAB
- 2) BRAKE SIGNAL DEDICATED FOR BODY BUILDER USE-IN CAB
- 3) R-STATOR SIGNAL DEDICATED FOR BODY BUILDER USE-IN CAB
- 4) BATTERY SHUT-OFF
- 5) 160 AMP ALTERNATOR-MINIMUM Δ
- 6) THROTTLE LIMIT CAPABILITY FOR NON-OPERATE IN GEAR SYSTEM
- 7) THROTTLE ADVANCE ACCES Δ
- 8) 15 AMP CIRCUITS PER LIGHT FOR ALL LIGHTS Δ
- 9) FREIGHTLINER M2 CHASSIS REQUIRES 353-028 VEHICLE INTERFACE WIRING Δ
- 10) "COMMON INTERFACE" SIGNALS IN CAB AS PER 800-0487 Δ

- 1) MUST BE RP170 COMPLIANT, IF POSSIBLE.
- 2) BRAKE AND TURN SIGNAL MUST BE SEPARATED.



C-CHASSIS ELECTRICAL REQUIREMENTS TABLE

CHASSIS INFORMATION	FIVSS SIGNALS AT BACK OF CAB INSIDE THE FRAME RAIL	COMMON INTERFACE	SEPARATE TURN AND BRAKE SIGNALS	MULTIFLEX PROGRAMMING FROM CHASSIS MANUFACTURER	NOTES:
MACK MRU/TEL# Δ	FIVSS SIGNALS AT BACK OF CAB INSIDE THE FRAME RAIL CONTROL LINK III - SALES CODE M10003 FOR MR. 8830030 FOR LR	CONTROL LINK II - SALES CODE M10003 FOR MR. 8830030 FOR LR	STANDARD	N/A	M10003 GETS THE UPRIGHT CENTER PANEL WORK BRAKE CODE - SKYVAL. COOLER TUBE RELOCATION CODE - PRL_PKP
MACK GRANITE	BODY LINK III - SALES CODE 8830026	N/A	STANDARD	N/A	THE FIVSS CONNECTOR FOR THE BODY LINK III IS DIFFERENT FROM THE ONE FOR THE CONTROL LINK.
AUTOCAR	RP170- CODE-8742000	RP170- CODE-8742000	STANDARD RP170	N/A	
HIRO	STANDARD - BUT COMBINED STOP/TURN	N/A	N/A	N/A	USES HEIL INSTALLED/DEVELOPED COMMON INTERFACE CABLE.
INTERNATIONAL	ORDER CODE: 08HAB	N/A	N/A	CUSTOM	
C-C	STANDARD	STANDARD	STANDARD	N/A	12V24 FOR CORRECT ENGINE/PTO
UD	N/A	N/A	N/A	N/A	
FREIGHTLINER	RP170 : 33U-012	RP170 : 33U-012	STANDARD RP170 : 33U-012	N/A	
PETERBILT CONVENTIONAL CAB	STANDARD	214-0150 THROTTLE AT FIREWALL	STANDARD	N/A	
KENSWORTH	REQUIRES OPTIONAL BODY CONNECTOR	REQUIRES OPTIONAL REMOTE PTO HARNESS	ORDER CODE: 9072022	N/A	
PETERBILT COE 520	RP170 : 33U-012	RP170 : 33U-012	STANDARD	N/A	