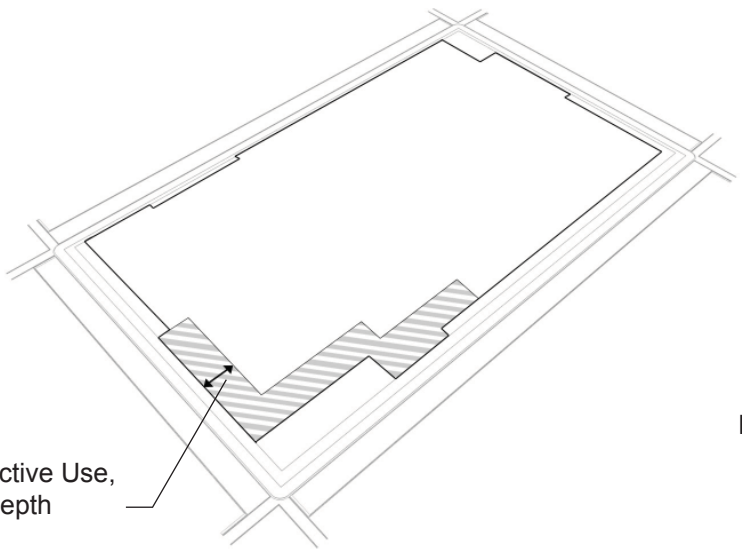
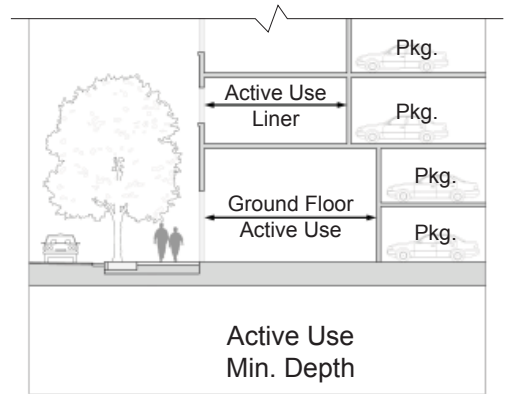
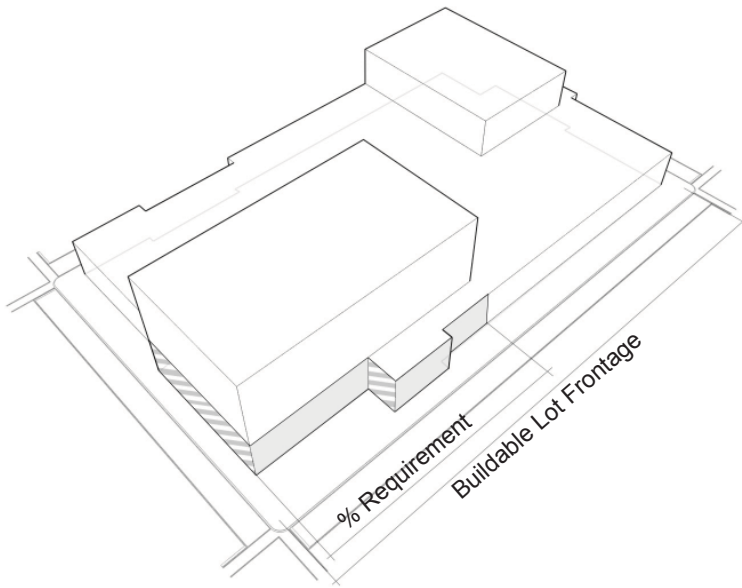
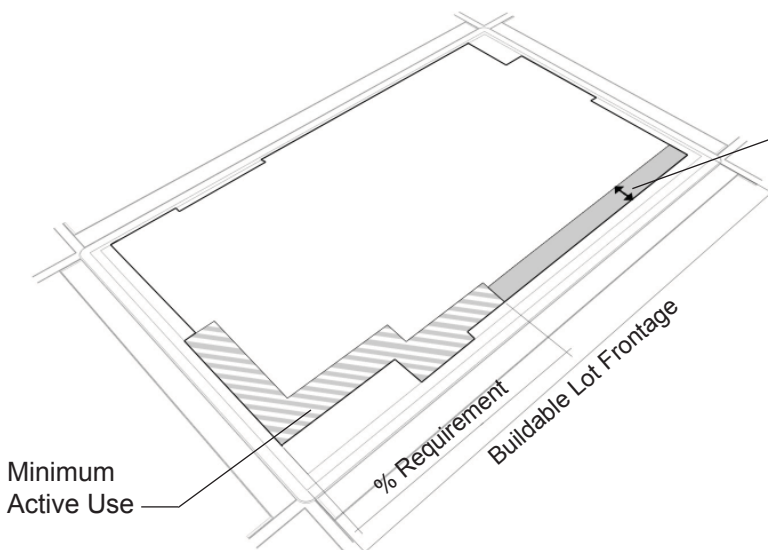

DIAGRAM: 1
 ACTIVE USE/
 ACTIVE USE GROUND FLOOR/
 ACTIVE USE LINER/
 ACTIVE USE DEPTH



SAMPLE CALCULATION
 Lot Frontage - Setbacks = Buildable Lot Frontage (100 lf)
 80%* Ground Floor Active Uses = 80 lf
 60%* Ground Floor Active Uses = 60 lf
 (*varies by Subdistrict)



Active Use Exceeding the
 Minimum Required Frontage
 Min. Depth = 15 feet

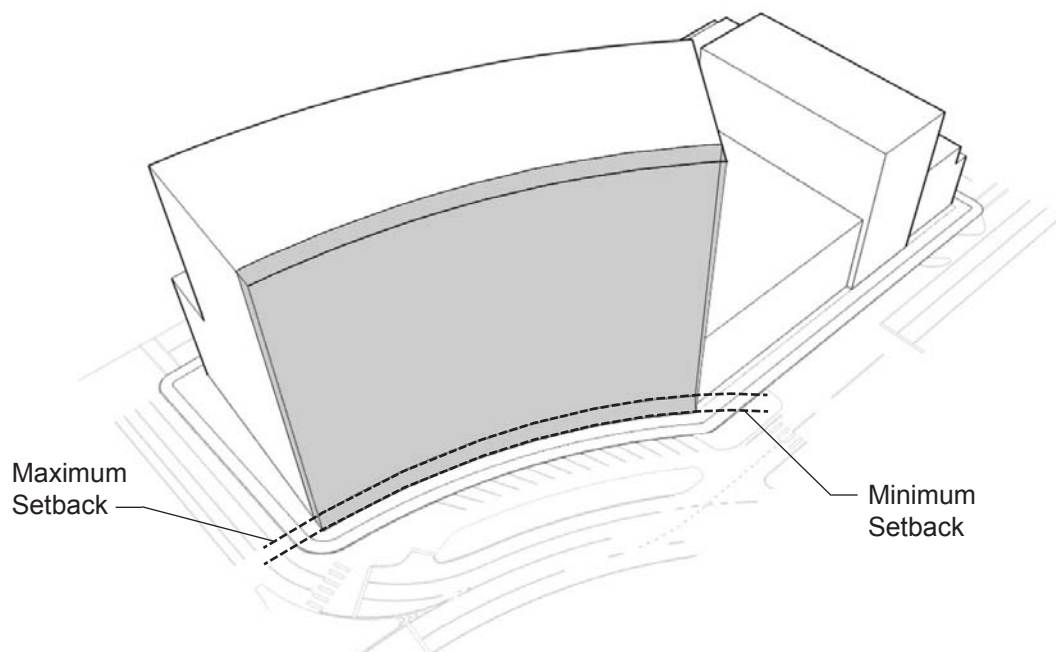
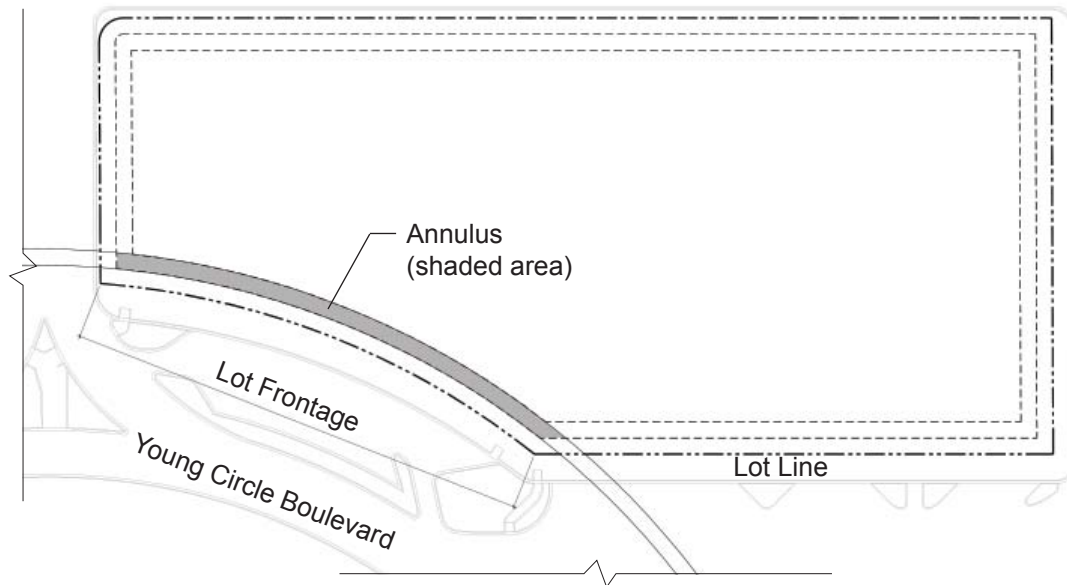
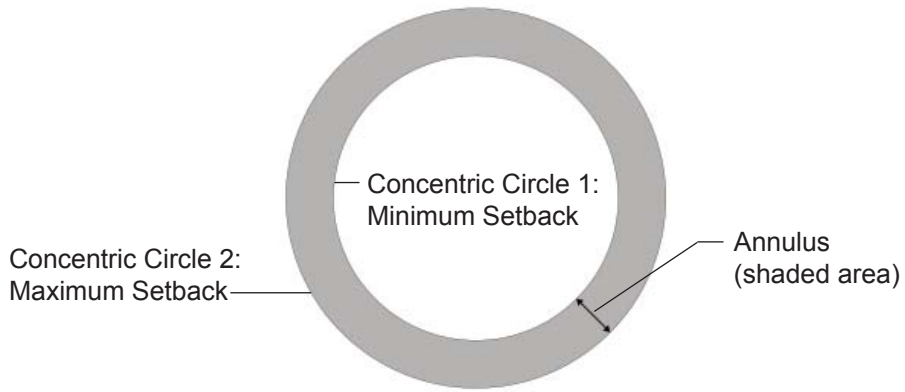

DIAGRAM: 3
BASE/
TOWER

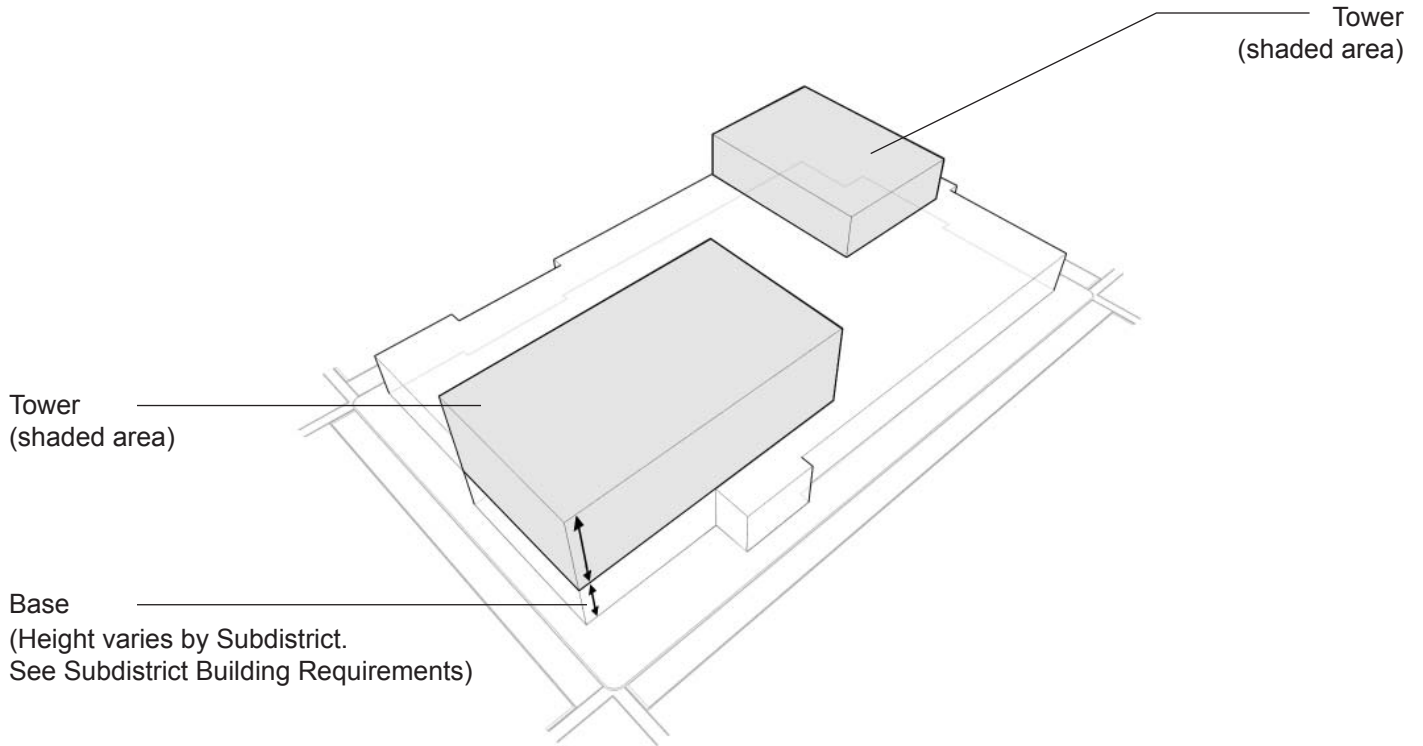

DIAGRAM: 4
BLANK WALL

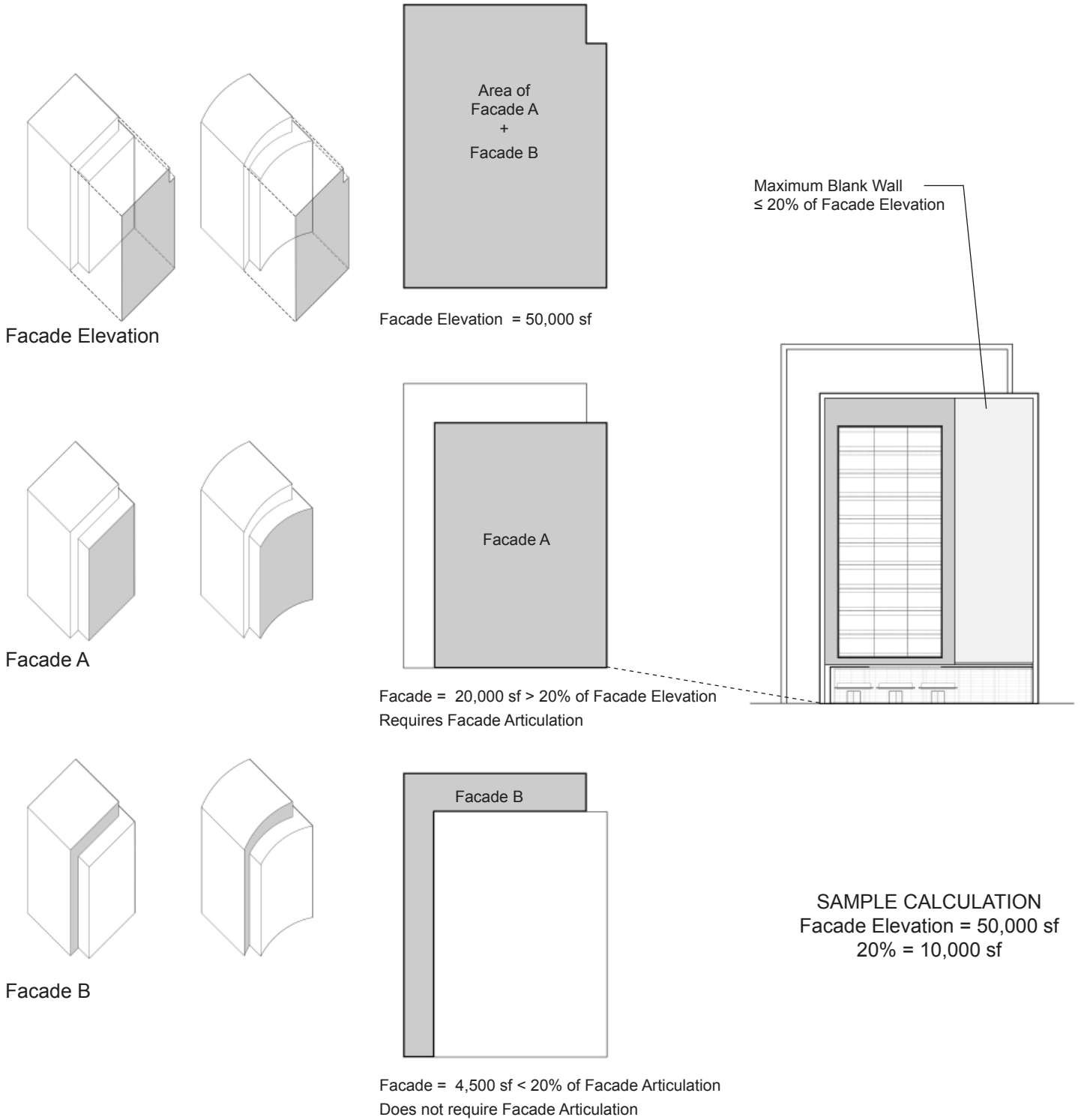

DIAGRAM: 5
BUILDING FRONTAGE

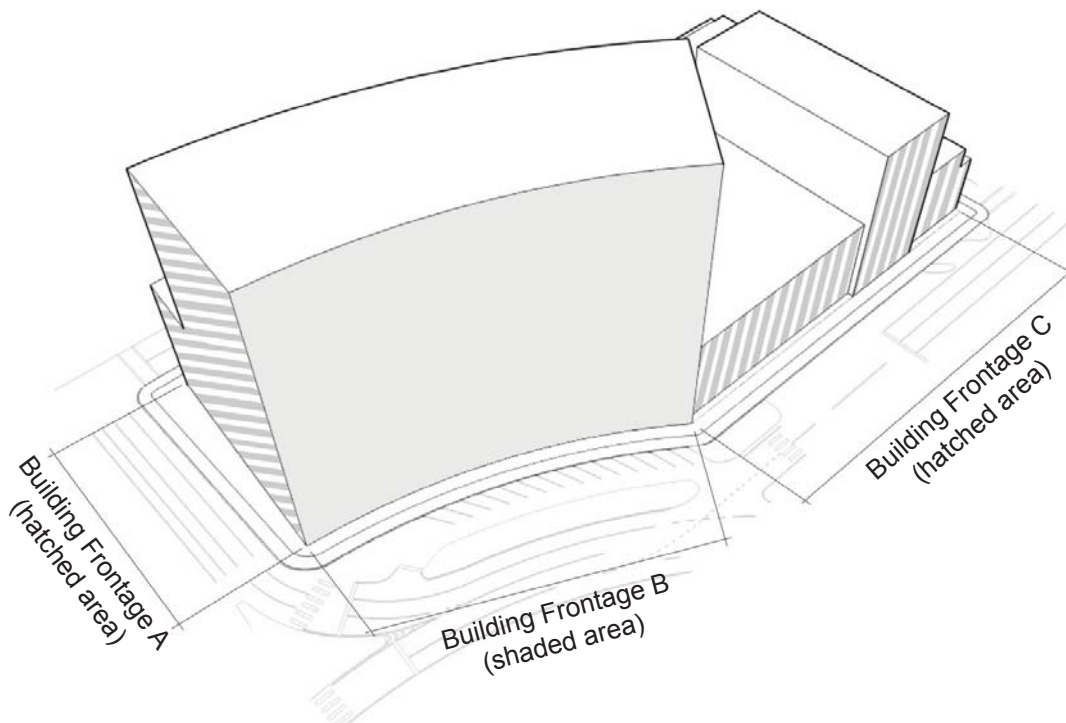
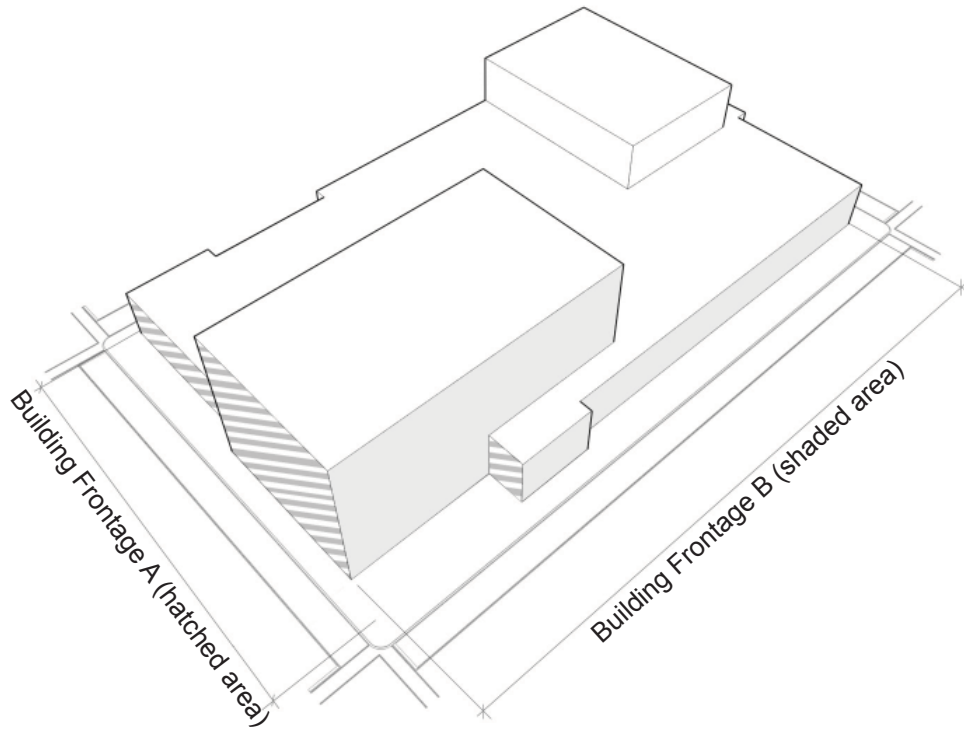

DIAGRAM: 6
FOOTPRINT

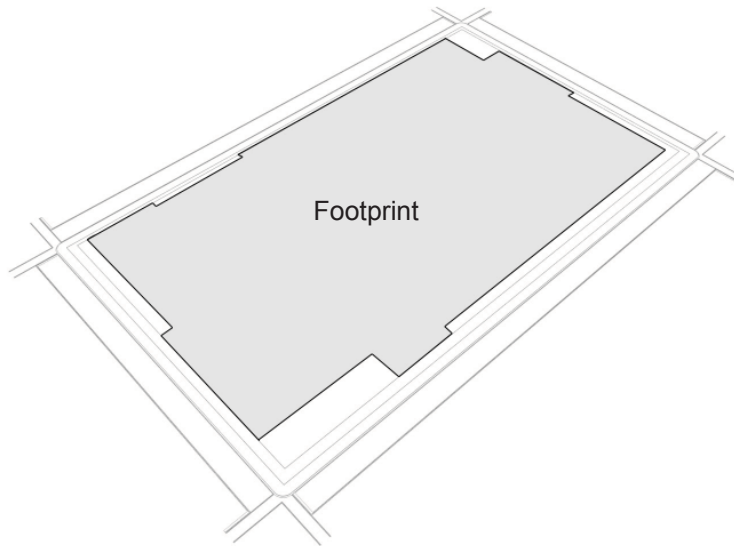
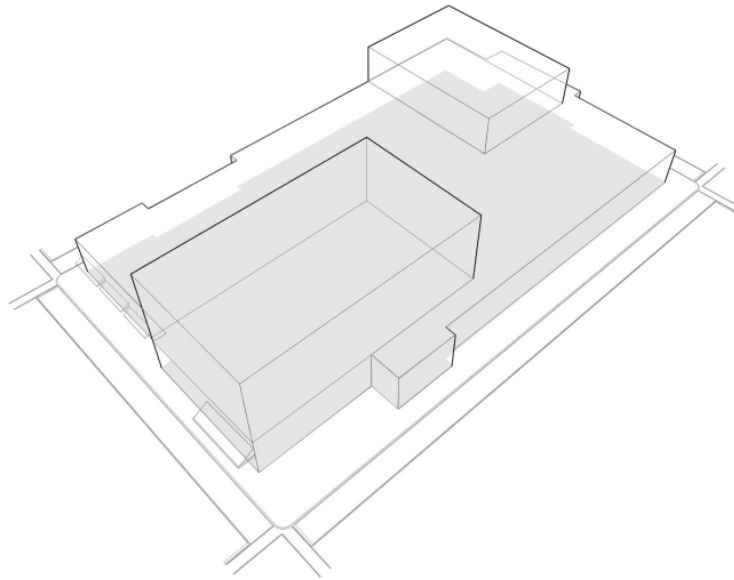

DIAGRAM: 7
GROUND FLOOR USES

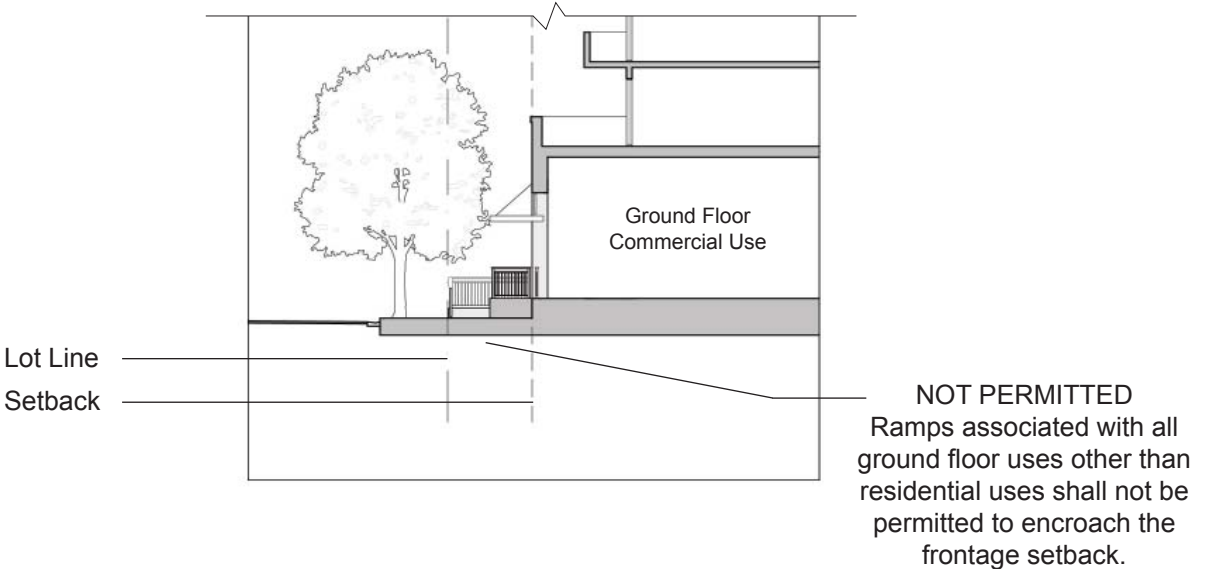
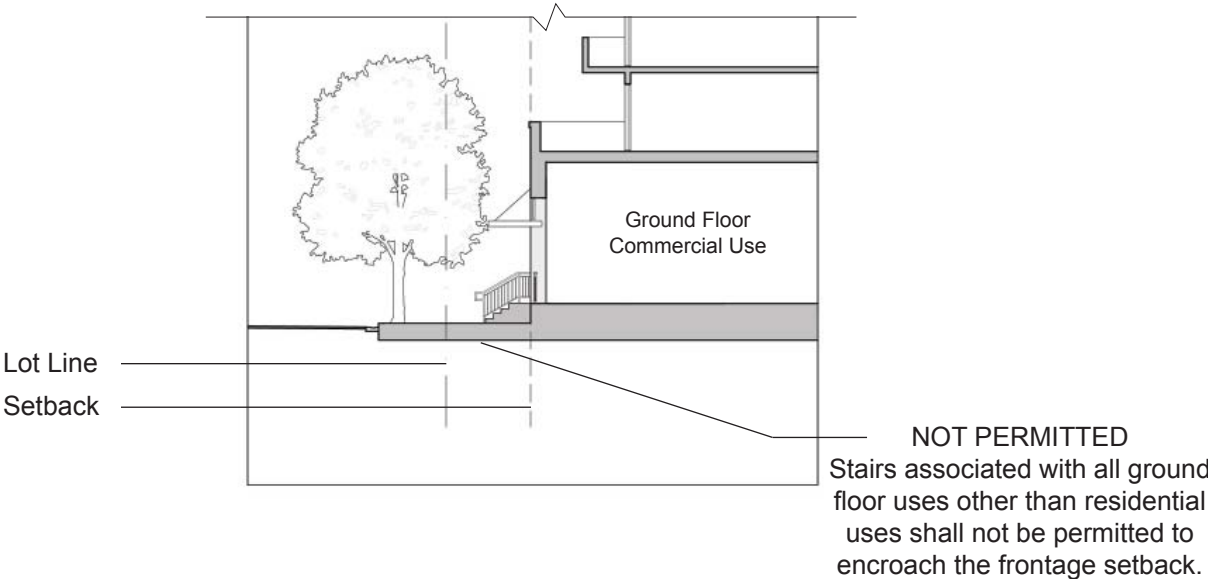
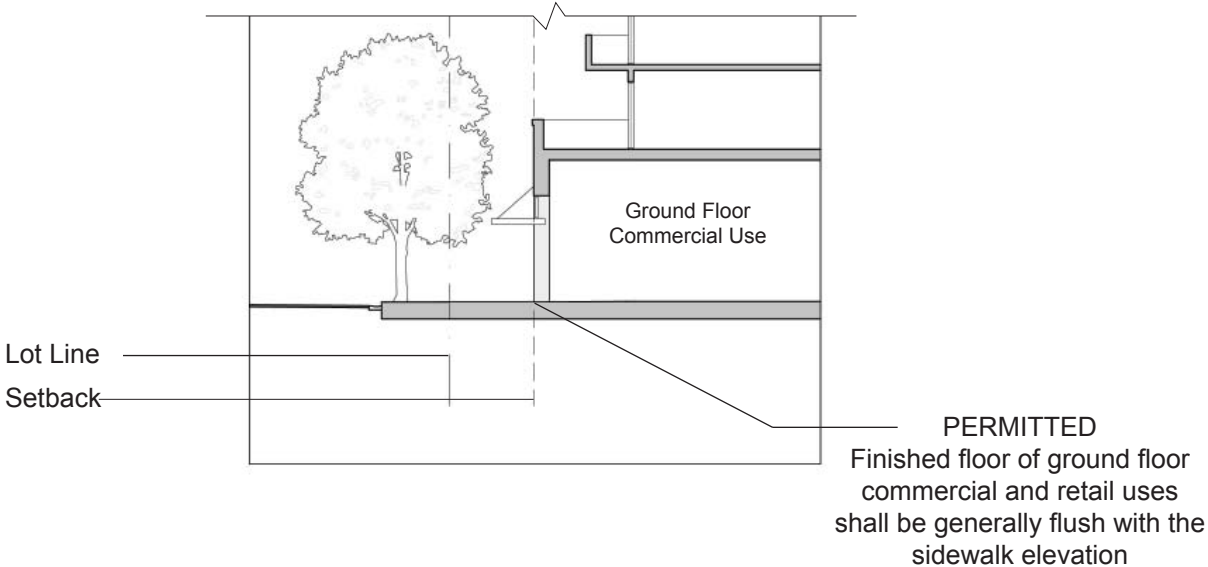
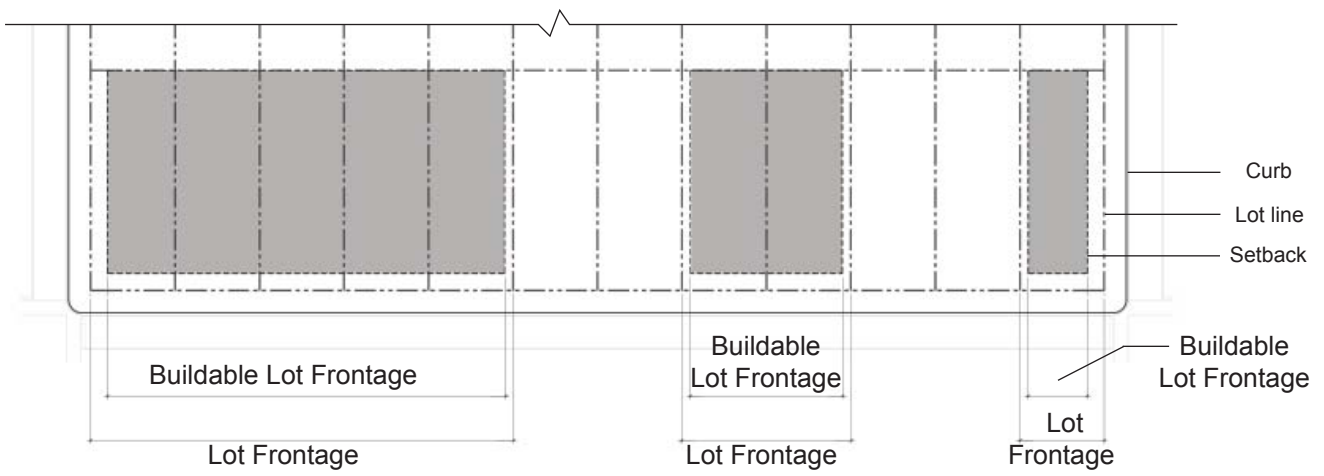
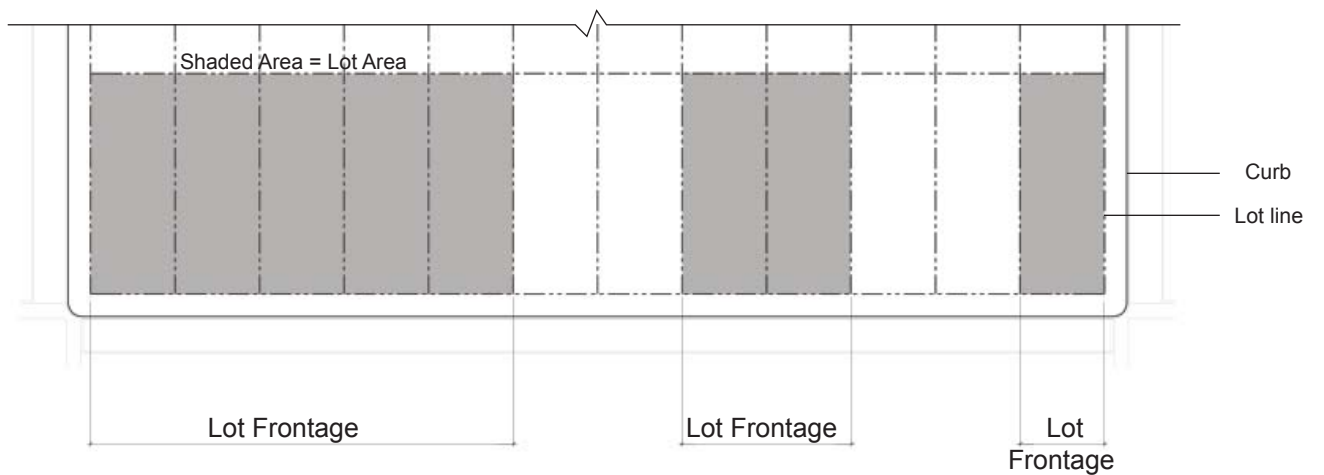
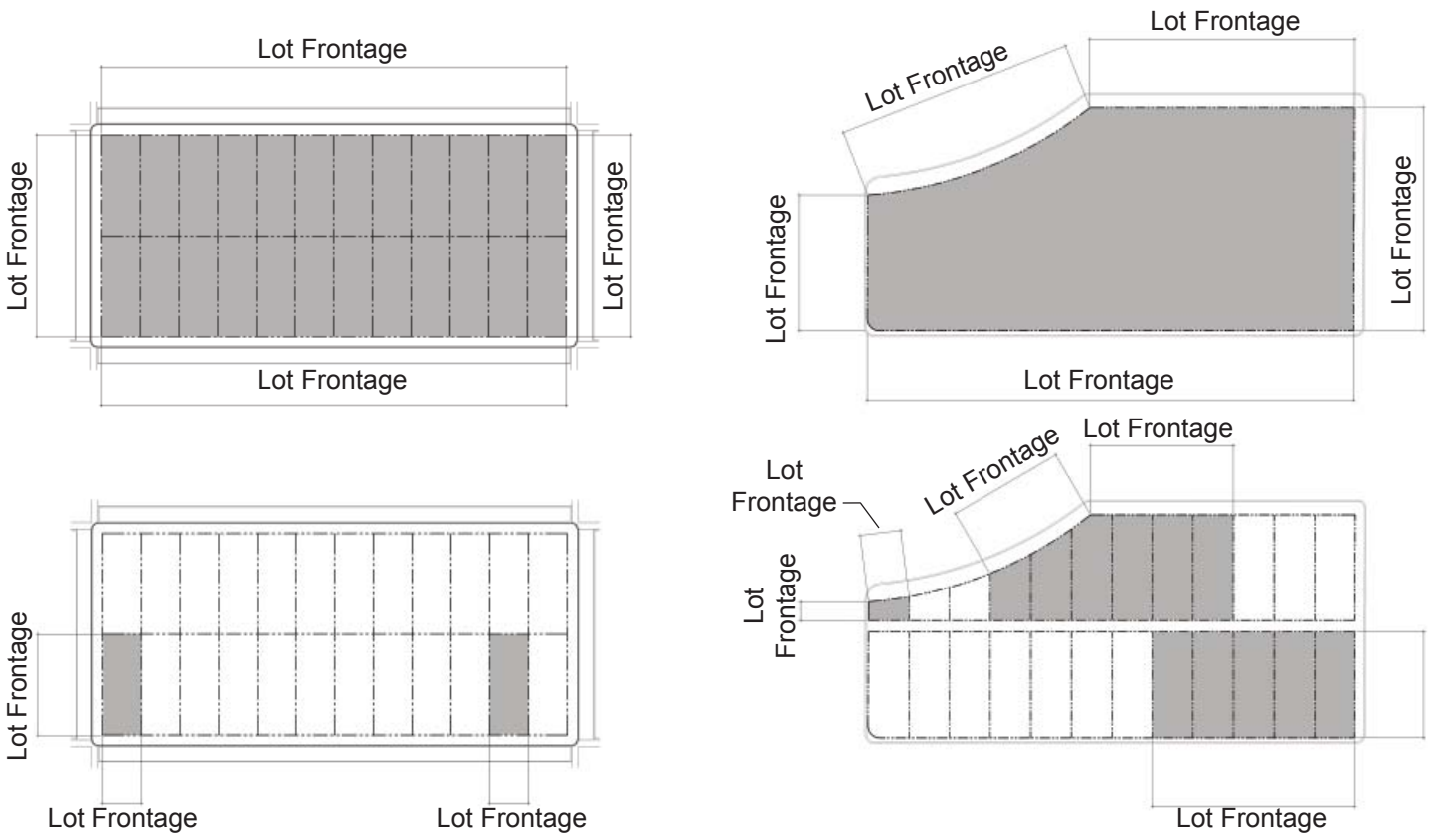
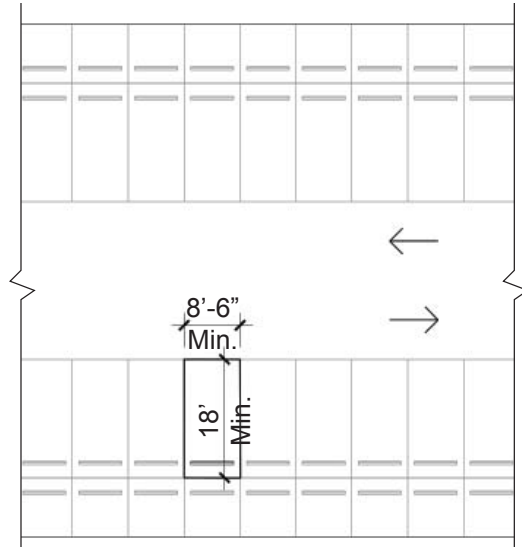
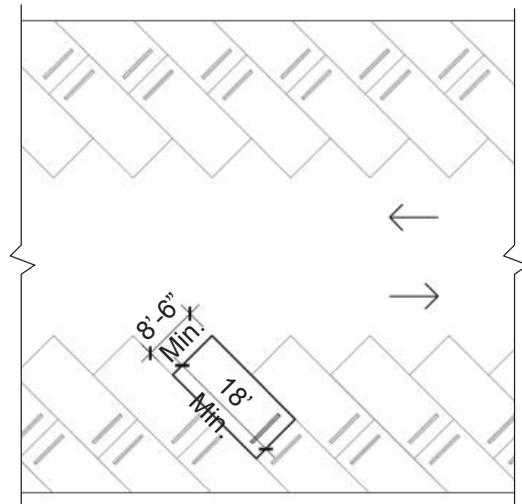

DIAGRAM: 8
 LOT FRONTAGE/
 LOT FRONTAGE, BUILDABLE





90 Degree Parking



Angled Parking

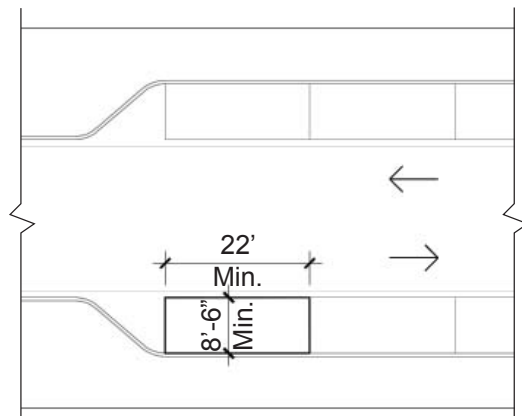

Parallel Parking

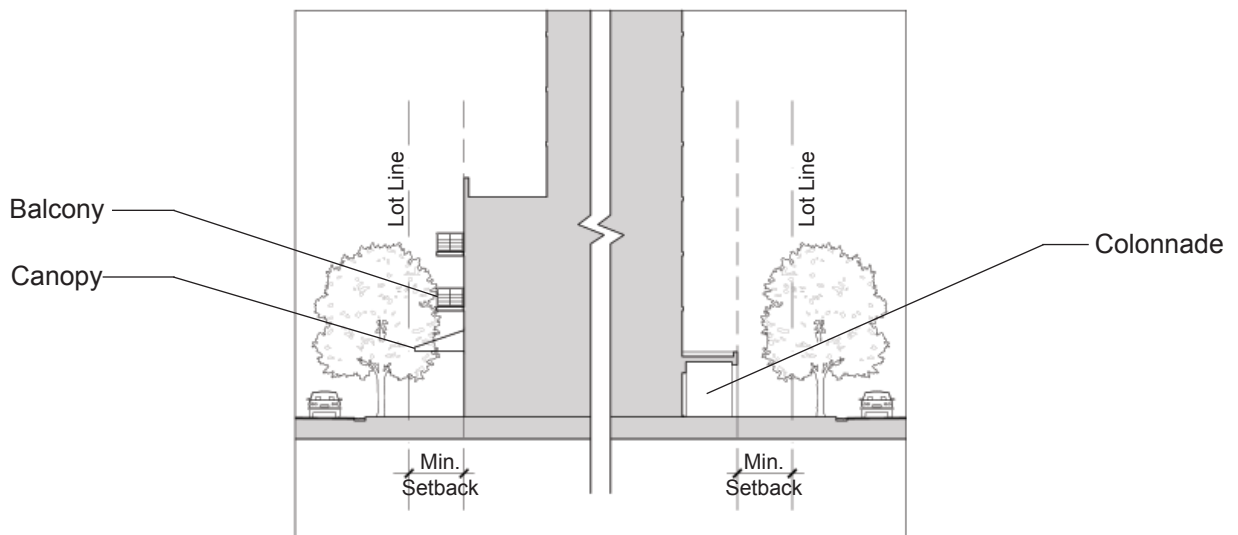
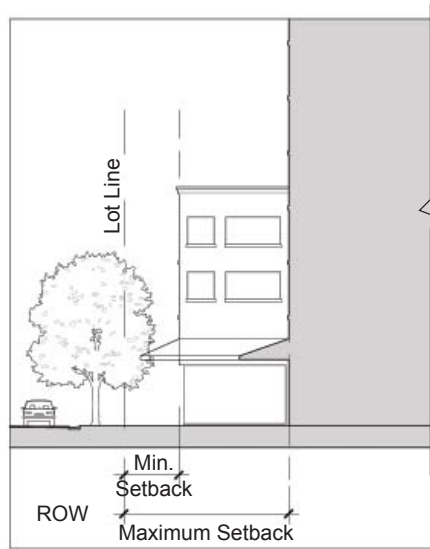
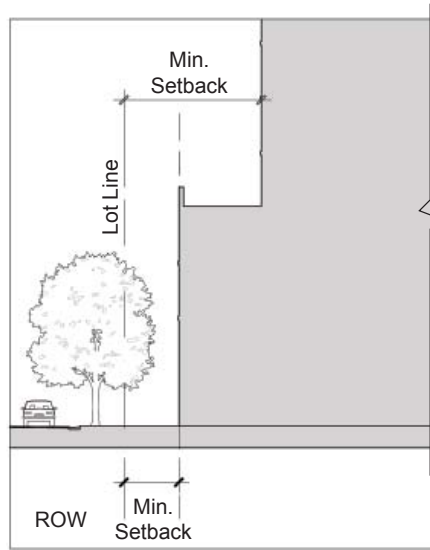
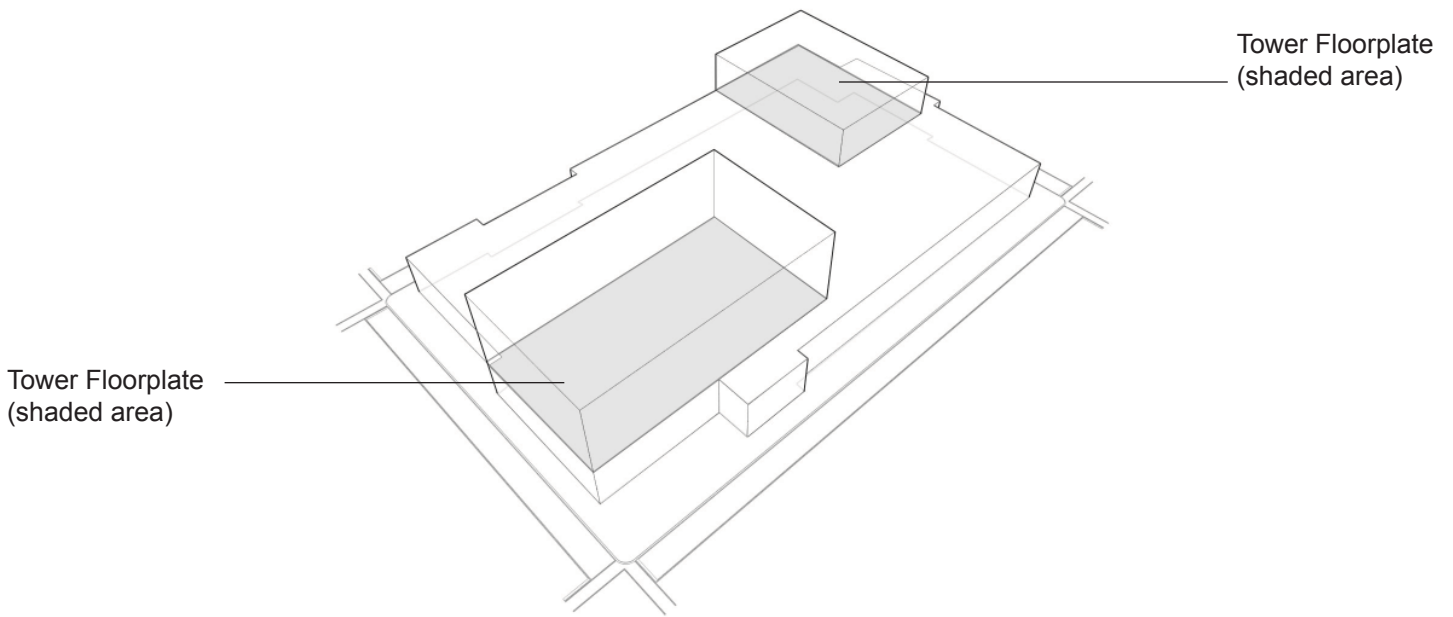

DIAGRAM: 11
TOWER FLOORPLATE



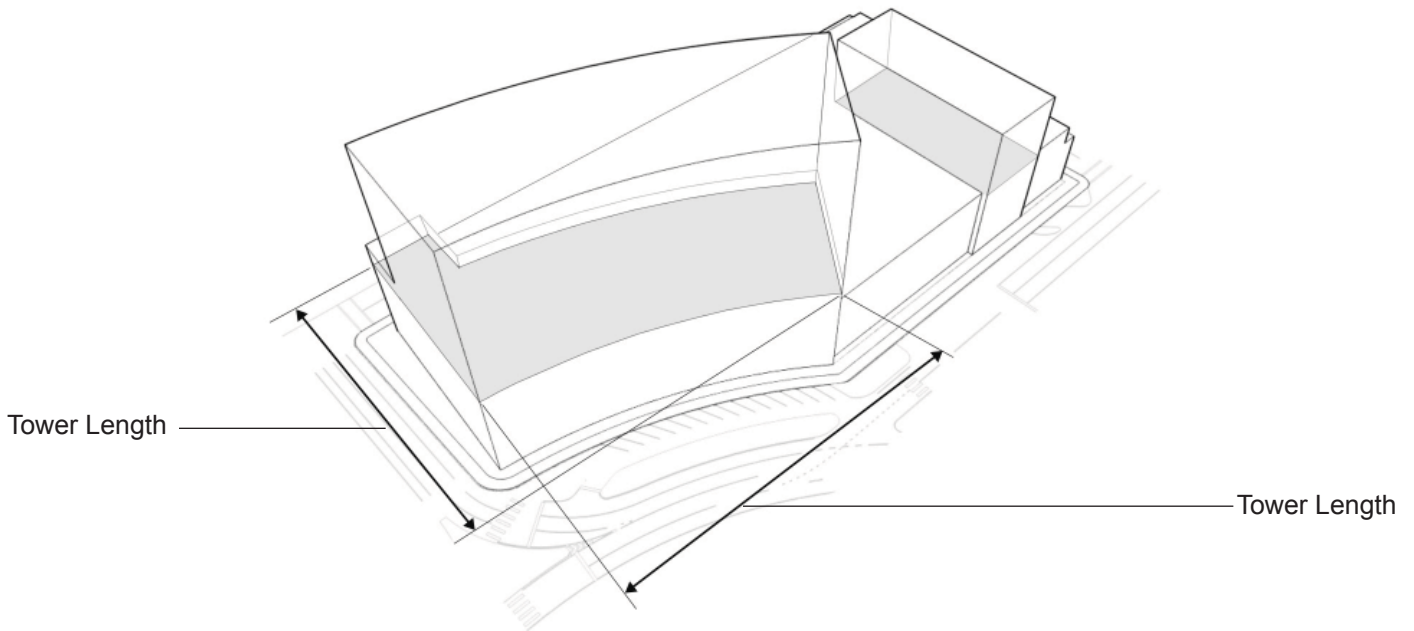
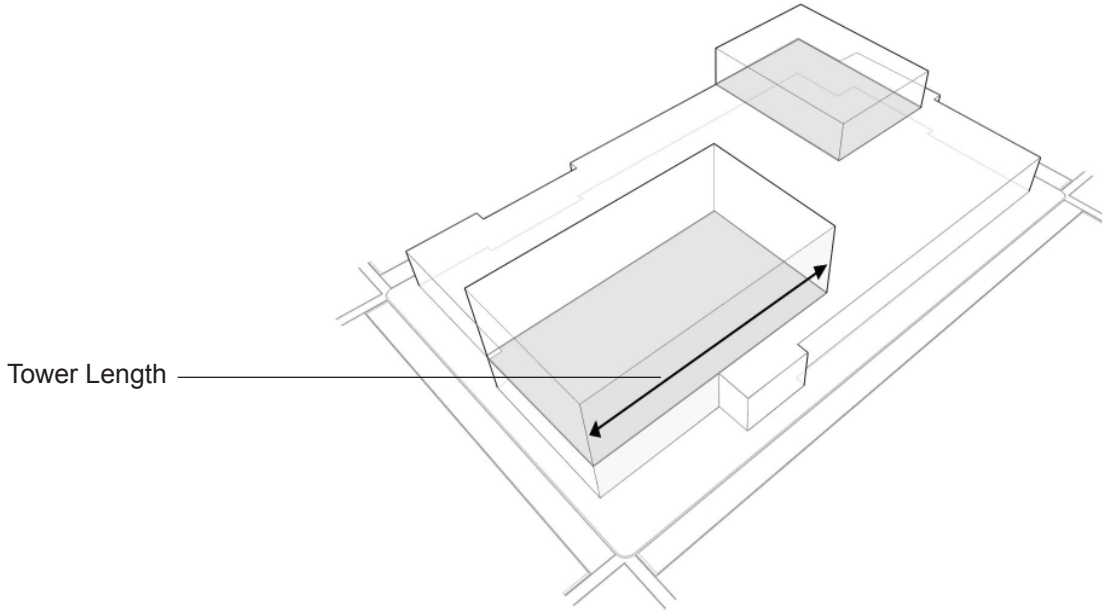
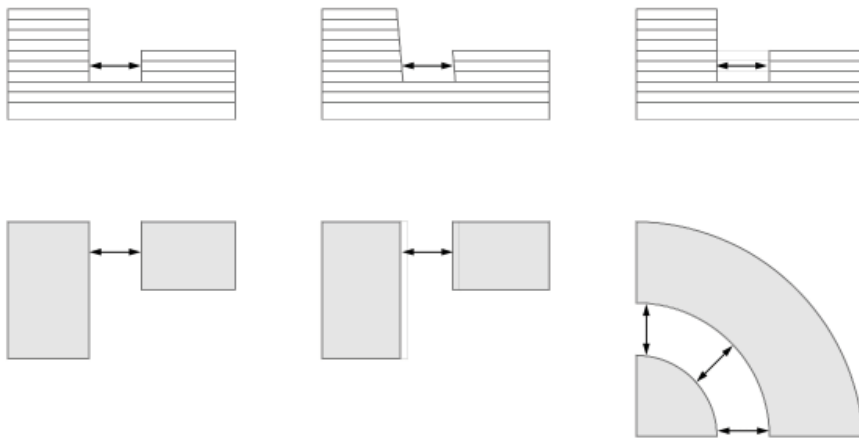
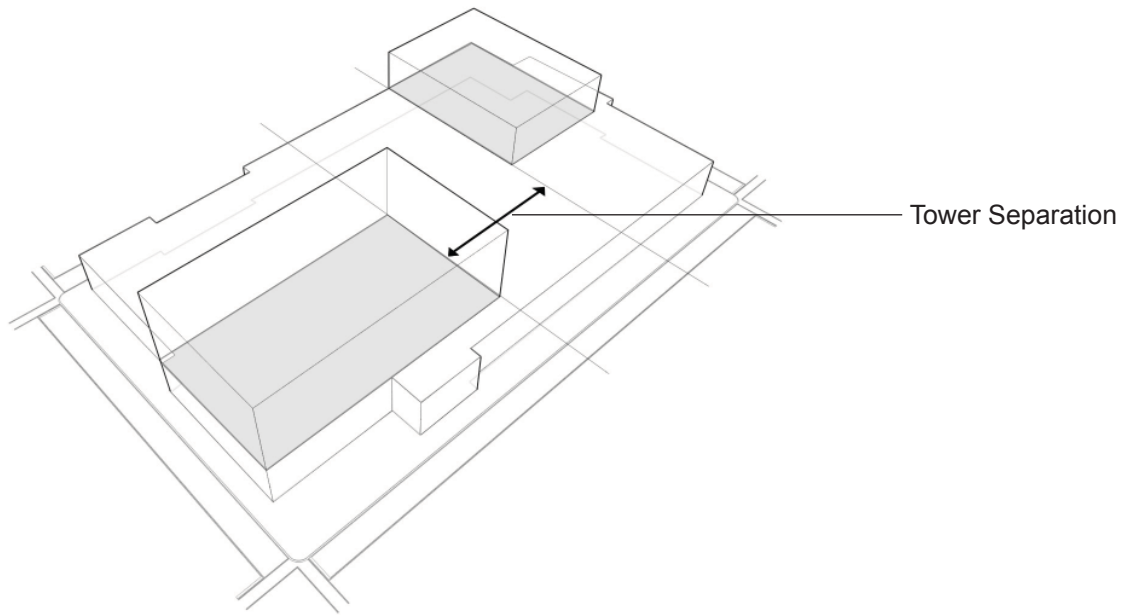
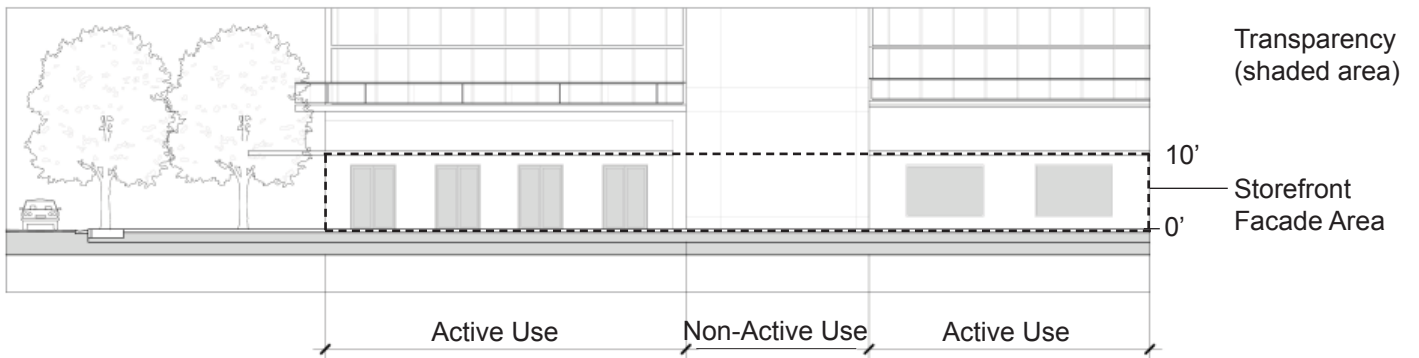

DIAGRAM: 13
TOWER SEPARATION



Tower Floorplate
Separation

DIAGRAM: 14
TRANSPARENCY /
STOREFRONT FACADE AREA



SAMPLE CALCULATION
Active Use Storefront area = 1,000 sf
50%* minimum Transparency = 500 sf
*varies by Subdistrict and Street Designation

DIAGRAM: 15
YOUNG CIRCLE
TOWER OFFSET SETBACK

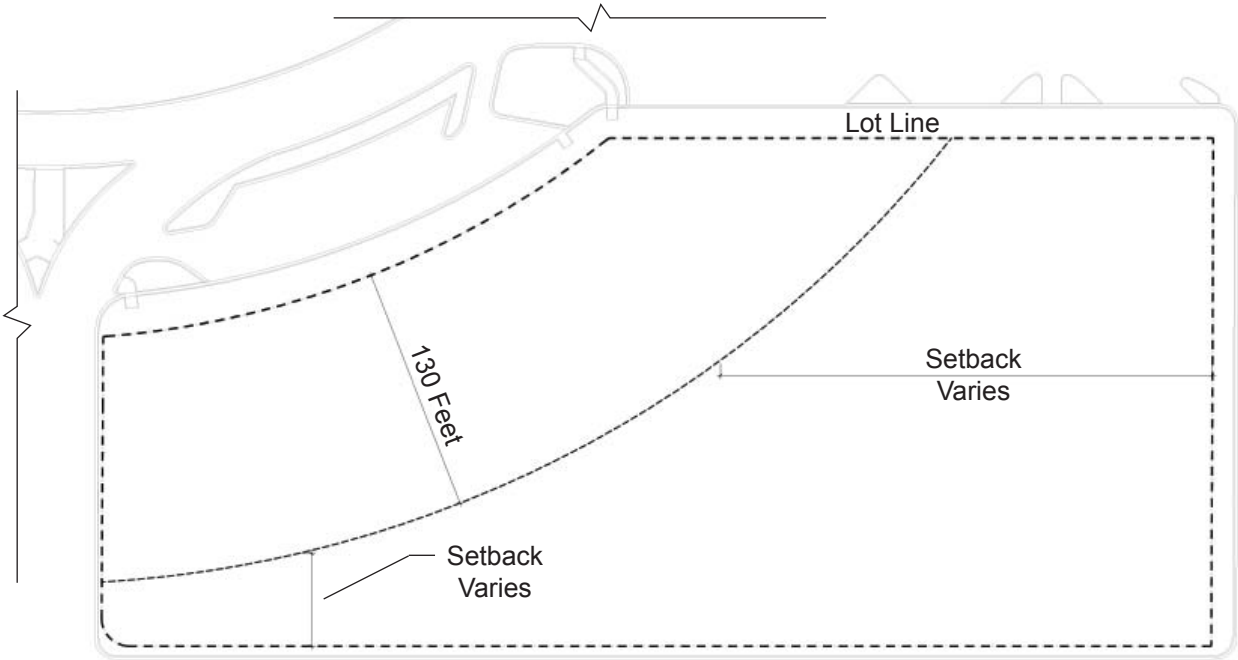
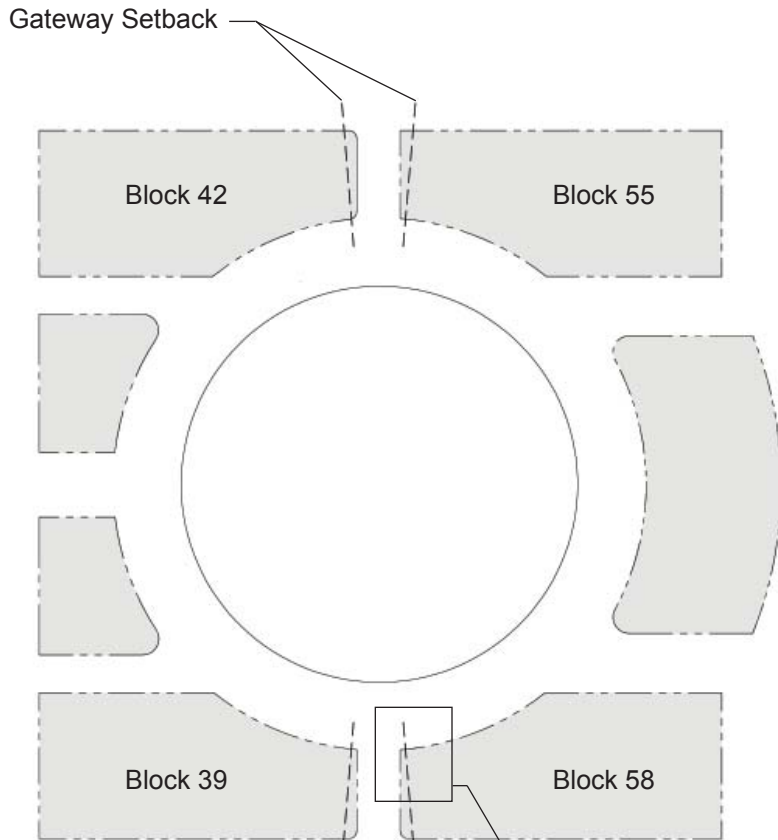

DIAGRAM: 16
YOUNG CIRCLE
GATEWAY SETBACK



Gateway Setback

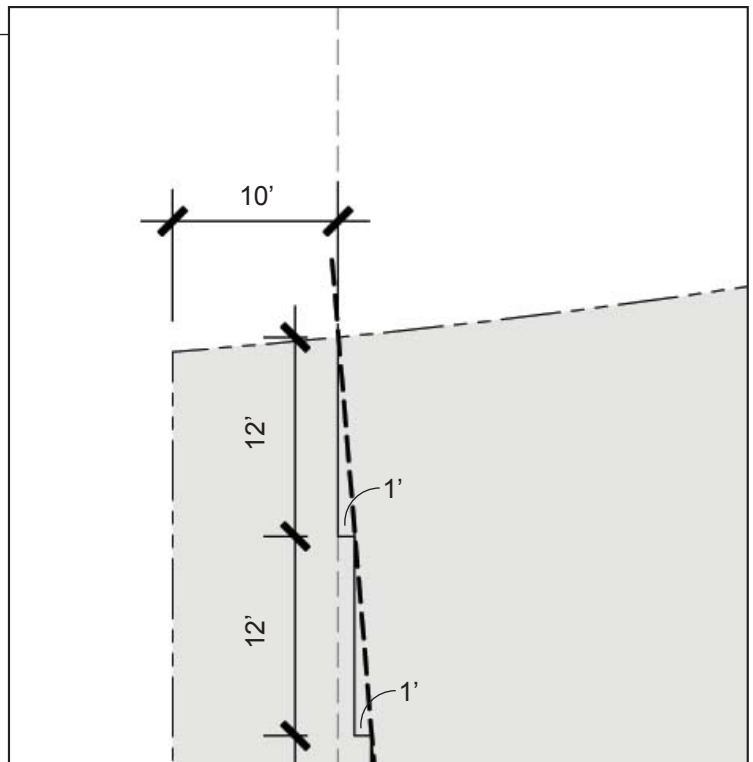

DIAGRAM: 17
WALK UP GARDEN

